

Service Manual

3CX, 4CX, 214, 215, 217
& VARIANTS

Backhoe Loader

From M/c No. 930000 Onwards
From M/c No. 903000 Onwards (USA)

PUBLISHED BY THE
TECHNICAL PUBLICATIONS DEPARTMENT
OF JCB SERVICE; © WORLD PARTS CENTRE,
WATERLOO PARK, UTTOXETER, ST14 5PA
ENGLAND
Tel. ROCESTER (01889) 590312
PRINTED IN ENGLAND

Publication No. 9803/3280

General Information	1
Care & Safety	2
Routine Maintenance	3
Attachments	A
Body & Framework	B
Electrics	C
Controls	D
Hydraulics	E
Transmission	F
Brakes	G
Steering	H
Engine	K

Introduction

This publication is designed for the benefit of JCB Distributor Service Engineers who are receiving, or have received, training by JCB Technical Training Department.

These personnel should have a sound knowledge of workshop practice, safety procedures, and general techniques associated with the maintenance and repair of hydraulic earthmoving equipment.

Renewal of oil seals, gaskets, etc., and any component showing obvious signs of wear or damage is expected as a matter of course. It is expected that components will be cleaned and lubricated where appropriate, and that any opened hose or pipe connections will be blanked to prevent excessive loss of hydraulic fluid and ingress of dirt. Finally, please remember above all else **SAFETY MUST COME FIRST!**

The manual is compiled in sections, the first three are numbered and contain information as follows:

- 1** = **General Information** - includes torque settings and service tools.
- 2** = **Care & Safety** - includes warnings and cautions pertinent to aspects of workshop procedures etc.
- 3** = **Routine Maintenance** - includes service schedules and recommended lubricants for all the

machine.

The remaining sections are alphabetically coded and deal with Dismantling, Overhaul etc. of specific components, for example:

- A** = **Attachments**
- B** = **Body & Framework** ...etc.

The page numbering in each alphabetically coded section is not continuous. This allows for the insertion of new items in later issues of the manual.

Section contents, technical data, circuit descriptions, operation descriptions etc are inserted at the beginning of each alphabetically coded section.

All sections are listed on the front cover; tabbed divider cards align directly with individual sections on the front cover for rapid reference.

Where a torque setting is given as a single figure it may be varied by plus or minus 3%. Torque figures indicated are for dry threads, hence for lubricated threads may be reduced by one third.

With the exception of slewing operations 'Left Hand' and 'Right Hand' are as viewed from the rear of the machine facing forwards.







Machine Nomenclature

In this Service Manual, reference is made to machine models, e.g. 3CX, 4CX, these are European machine model names. North American machine models have different names, the table below shows the European and the equivalent North American nomenclature.

European		North American
3CX	=	214
4CX	=	214S, 215S, 217S

Colour Coding

The following colour coding, used on illustrations to denote various conditions of oil pressure and flow, is standardised throughout JCB Service publications.

-  **Red** — **Full Pressure**
Pressure generated from operation of a service. Depending on application this may be anything between neutral circuit pressure and M.R.V. operating pressure.
-  **Pink** — **Pressure**
Pressure that is above neutral circuit pressure but lower than that denoted by red.
-  **Orange** — **Servo**
Oil pressure used in controlling a device (servo).
-  **Blue** — **Neutral**
Neutral circuit pressure.
-  **Green** — **Exhaust**
-  **Light Green** — **Cavitation**
Oil subjected to a partial vacuum due to a drop in pressure (cavitation).
-  **Yellow** — **Lock Up**
Oil trapped within a chamber or line, preventing movement of components (lock up).

A390940

Contents	Page No.
Machine Identification Plate	1 - 1
Typical Vehicle Identification Number (VIN)	1 - 1
Typical Engine Identification Number	1 - 1
Serial Plates	1 - 2
Torque Settings	2 - 1
Service Tools Numerical List	3 - 1
Service Tools	
- Body & Framework	4 - 1
- Electrics	4 - 4
- Hydraulics	4 - 6
- Transmission	4 - 10
- Engine	4 - 19
Sealing and Retaining Compounds	5 - 1

Machine Identification Plate

Your machine has an identification plate mounted on the loader tower. The serial numbers of the machine and its major units are stamped on the plate.

The serial number of each major unit is also stamped on the unit itself. If a major unit is replaced by a new one, the serial number on the identification plate will be wrong. Either stamp the new number of the unit on the identification plate, or simply stamp out the old number. This will prevent the wrong unit number being quoted when replacement parts are ordered.

The machine and engine serial numbers can help identify exactly the type of equipment you have.

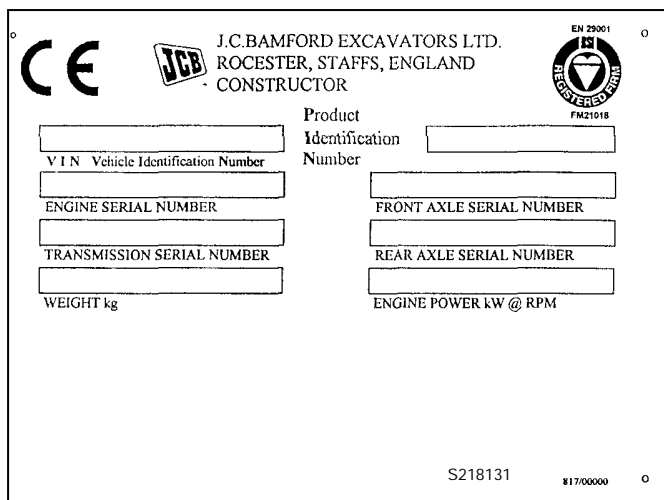

U.K. and R.O.W.

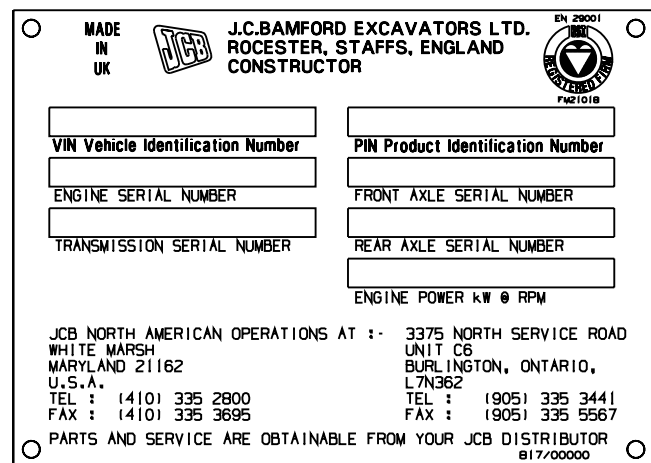

North America

A246740

Typical Vehicle Identification Number (VIN)

SLP 3CX T S V E 930000
A B C D E F G

- A World Manufacturer Identification
- B Machine Model
- C Steer Type (T= 2WS, F=4WS)
- D Build Type (S=Sideshift, C=Centremount, L=Loader)
- E Year of Manufacture:
2 = 2002
3 = 2003
4 = 2004
5 = 2005
6 = 2006
7 = 2007
8 = 2008
- F Manufacturer Location (E = England)
- G Product Identification Number (PIN)

Typical Engine Identification Number

AB 50262 U 500405 P
A B C D E

- A Engine Type
AB = 4 cylinder turbo
- B Build Number
- C Country of Origin
- D Engine Sequence Number
- E Year of Manufacture

Serial Plates

- A** Front Axle (2WS machine)
- B** Front Axle (4WS machine)
- C** Rear Axle (2WS machine)
- D** Rear Axle (4WS machine)
- E** Synchro Shuttle Transmission
- F** Powershift Transmission
- G** Engine

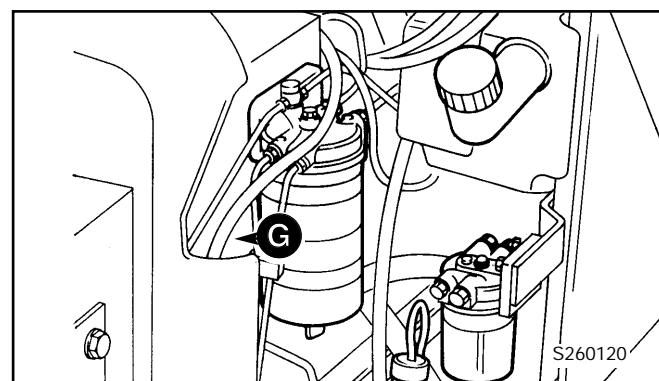
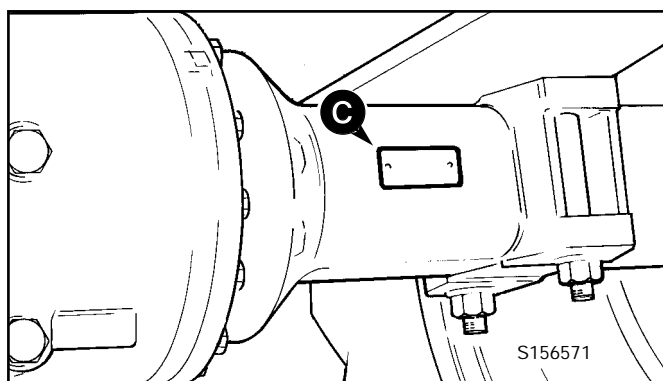
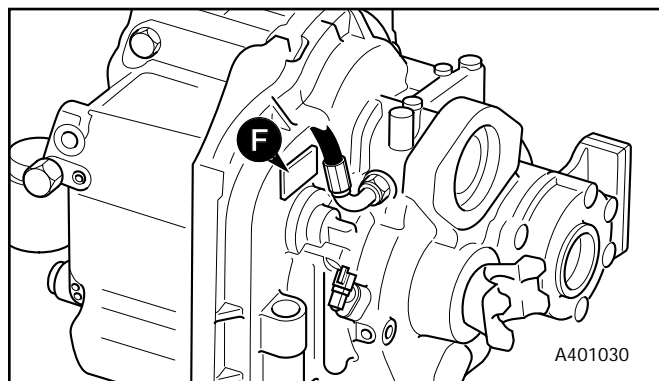
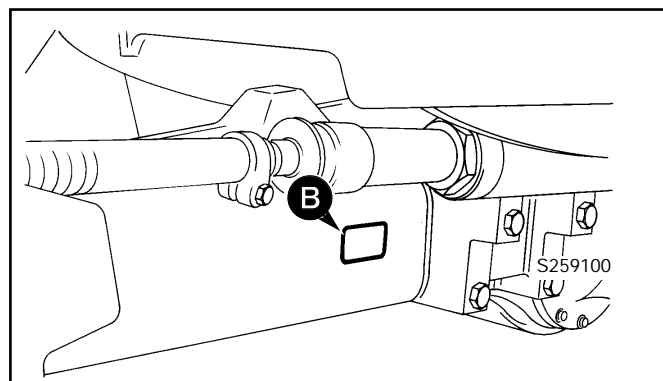
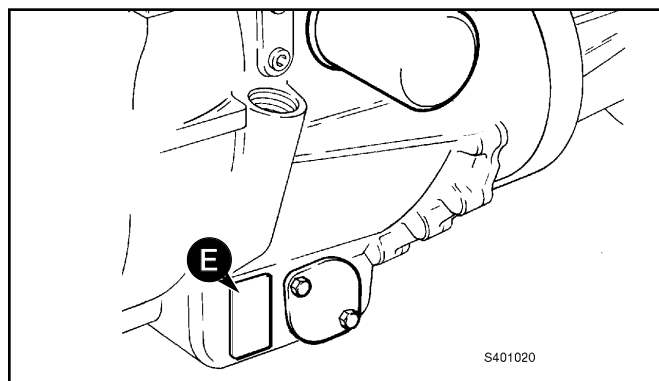
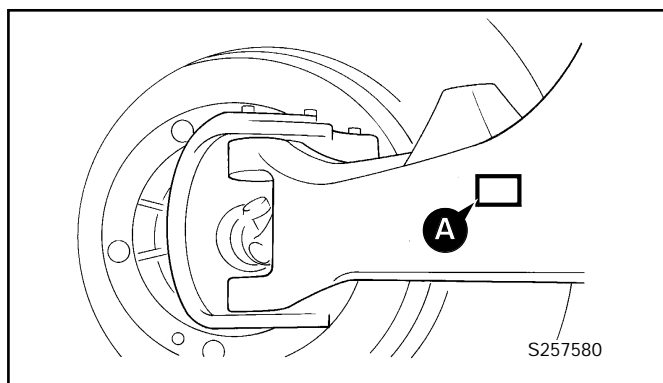
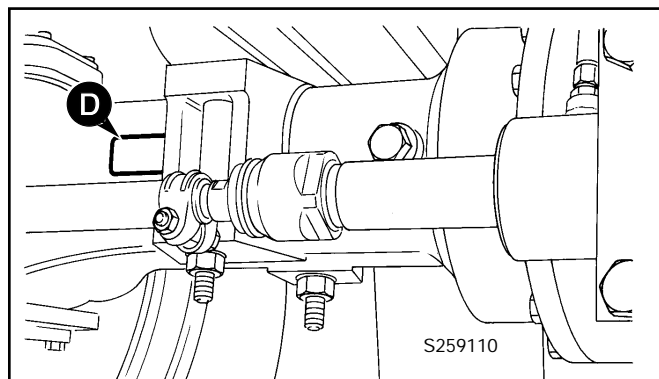

Torque Settings

Use only where no torque setting is specified in the text. Values are for dry threads and may be within three per cent of the figures stated. For lubricated threads the values should be REDUCED by one third.

UNF Grade 'S' Bolts

Bolt Size in	(mm)	Hexagon (A/F) in	Torque Settings		
			Nm	kgf m	lbf ft
1/4	(6.3)	7/16	14	1.4	10
5/16	(7.9)	1/2	28	2.8	20
3/8	(9.5)	9/16	49	5.0	36
7/16	(11.1)	5/8	78	8.0	58
1/2	(12.7)	3/4	117	12.0	87
9/16	(14.3)	13/16	170	17.3	125
5/8	(15.9)	15/16	238	24.3	175
3/4	(19.0)	11/8	407	41.5	300
7/8	(22.2)	15/16	650	66.3	480
1	(25.4)	11/2	970	99.0	715
1 1/4	(31.7)	17/8	1940	198.0	1430
1 1/2	(38.1)	21/4	3390	345.0	2500

Metric Grade 8.8 Bolts

Bolt Size	(mm)	Hexagon (A/F) mm	Torque Settings		
			Nm	kgf m	lbf ft
M5	(5)	8	7	0.7	5
M6	(6)	10	12	1.2	9
M8	(8)	13	28	3.0	21
M10	(10)	17	56	5.7	42
M12	(12)	19	98	10	72
M16	(16)	24	244	25	180
M20	(20)	30	476	48	352
M24	(24)	36	822	84	607
M30	(30)	46	1633	166	1205
M36	(36)	55	2854	291	2105

Rivet Nut Bolts/Screws

Bolt Size	(mm)	Torque Settings (for steel rivet nuts)		
		Nm	kgf m	lbf ft
M3	(3)	1.2	0.12	0.9
M4	(4)	3.0	0.3	2.0
M5	(5)	6.0	0.6	4.5
M6	(6)	10.0	1.0	7.5
M8	(8)	24.0	2.5	18.0
M10	(10)	48.0	4.9	35.5
M12	(12)	82.0	8.4	60.5

Note: All bolts used on JCB machines are high tensile and must not be replaced by bolts of a lesser tensile specification.

Service Tools Numerical List

	Page No.		Page No.		
460/15708	Flow Test Adapter	4 - 13	825/00410	Crowfoot Wrench	4 - 4
460/15707	Banjo Bolt	4 - 13	825/99833	Adapter for 825/00410	4 - 4
1406/0011	Bonded Washer	4 - 7	826/01099	Rivet Nut	4 - 1
1406/0014	Bonded Washer	4 - 7	826/01101	Rivet Nut	4 - 1
1406/0018	Bonded Washer	4 - 7, 13	826/01102	Rivet Nut	4 - 1
1406/0021	Bonded Washer	4 - 6, 4 - 7	826/01103	Rivet Nut	4 - 1
1406/0029	Bonded Washer	4 - 7	826/01104	Rivet Nut	4 - 1
1604/0003	Male Adapter	4 - 7	826/01105	Rivet Nut	4 - 1
1604/0004	Male Adapter	4 - 7, 13	892/00011	Spool Clamp	4 - 8
1604/0006	Male Adapter	4 - 6, 4 - 7	892/00041	De-glazing Tool	4 - 19
1604/0008	Adapter	4 - 6	892/00047	Adapter	4 - 8
1606/0003	Male Adapter	4 - 7	892/00048	Adapter	4 - 8
1606/0004	Male Adapter	4 - 7	892/00049	Adapter	4 - 8
1606/0007	Male Adapter	4 - 7	892/00051	Adapter	4 - 8
1606/0008	Male Adapter	4 - 7	892/00055	Blanking Plug	4 - 8
1606/0009	Male Adapter	4 - 7	892/00056	Blanking Plug	4 - 8
1606/0012	Male Adapter	4 - 6, 4 - 7	892/00057	Blanking Plug	4 - 8
1606/0014	Male Adapter	4 - 7	892/00058	Blanking Plug	4 - 8
1606/0015	Male Adapter	4 - 6, 4 - 7	892/00059	Blanking Plug	4 - 8
1606/0017	Male Adapter	4 - 7	892/00060	Blanking Plug	4 - 8
1612/0006	Adapter	4 - 6	892/00071	Male Adapter	4 - 7
2401/0222	O-ring	4 - 13	892/00074	Female Connector	4 - 8
2403/0110	O-ring	4 - 13	892/00075	Female Connector	4 - 8
2403/0108	O-ring	4 - 13	892/00076	Female Connector	4 - 8
4101/0651	Retainer (High Strength)	5 - 1	892/00077	Female Connector	4 - 8
4101/0250	Threadlocker and Sealer (10 ml)	5 - 1	892/00078	Connector	4 - 6
4101/0251	Threadlocker and Sealer (50 ml)	5 - 1	892/00137	Micro-Bore Hose 1/4in. BSP, 3 Metres	4 - 7
4101/0451	Threadlocker	5 - 1	892/00167	Ram Seal Protection Sleeve 90 mm	4 - 9
4102/0502	High Strength Gasketing	5 - 1	892/00174	Measuring Cup	4 - 11
4102/0551	High Strength Threadlocker	5 - 1	892/00179	Bearing Press	4 - 10
4102/0933	Clear Silicone Sealant	5 - 1	892/00180	Seal Fitting Tool	4 - 9
4102/1212	Multi-Gasket	5 - 1	892/00181	Replacement Plastic Boss	4 - 9
4102/1951	Threadseal	5 - 1	892/00182	Bearing Pad Driver	4 - 12
4102/2309	Black Polyurethane Sealant	5 - 1	892/00223	Hand Pump	4 - 7
4103/2109	Ultra Fast Adhesive (310ml)	5 - 1	892/00224	Impulse Extractor	4 - 11
4104/0251	Activator (Aersol)	5 - 1	892/00225	Adapter for Extractor	4 - 11
4104/0253	Activator (Bottle)	5 - 1	892/00253	Pressure Test Kit	4 - 6
4104/1203	Active Wipe 205 (250g)	5 - 1	892/00255	Pressure Test Adapter	4 - 6
4104/1206	Active Wipe 205 (30 ml)	5 - 1	892/00256	Pressure Test Adapter	4 - 6
4104/1310	Hand Cleaner	4 - 1	892/00257	Pressure Test Adapter	4 - 6
4104/1538	JCB Cleaner & Degreaser	5 - 1	892/00258	Pressure Test Adapter	4 - 6
4104/1557	Cleaner/Degreaser (400 ml)	5 - 1	892/00259	Pressure Test Adapter	4 - 6
4201/4906	Black Primer 206J (30ml)	5 - 1	892/00260	Pressure Test Adapter	4 - 6
816/00017	Adapter	4 - 8	892/00261	Pressure Test Adapter	4 - 6
816/00189	Blanking Cap	4 - 8	892/00262	Pressure Test 'T' Adapter	4 - 6, 4 - 7
816/00190	Blanking Cap	4 - 8	892/00263	Pressure Test 'T' Adapter	4 - 6
816/00193	Blanking Cap	4 - 8	892/00264	Pressure Test 'T' Adapter	4 - 6
816/00196	Blanking Cap	4 - 8	892/00265	Pressure Test 'T' Adapter	4 - 6
816/00197	Blanking Cap	4 - 8	892/00268	Flow Monitoring Unit	4 - 6
816/00294	Blanking Cap	4 - 8	892/00269	Sensor Head	4 - 6
816/00439	Male Adapter	4 - 7	892/00270	Load Valve	4 - 6
816/00440	Male Adapter	4 - 7	892/00271	Adapter	4 - 6
816/15007	Male Adapter	4 - 7	892/00272	Adapter	4 - 6
816/15008	Male Adapter	4 - 7	892/00273	Sensor Head	4 - 6
816/15118	Pressure Test Adapter	4 - 6	892/00274	Adapter	4 - 7
816/20008	Adapter	4 - 6	892/00275	Adapter	4 - 6
816/20013	Adapter	4 - 6	892/00276	Adapter	4 - 6
816/50005	Adapter	4 - 8	892/00277	Adapter	4 - 6
816/50043	Adapter	4 - 8	892/00278	Gauge	4 - 7
816/55038	Pressure Test 'T' Adapter	4 - 6	892/00279	Gauge	4 - 7
816/55040	Pressure Test 'T' Adapter	4 - 6	892/00282	Shunt	4 - 4
816/60096	Adapter	4 - 8	892/00283	Tool Kit Case	4 - 4

Service Tools Numerical List

	Page No.		Page No.		
892/00284	Tachometer	4 - 4	892/01076	Synchro Shuttle Support Plate	
892/00285	Hydraulic Oil Temperature Probe	4 - 4		Transfer gear end float setting	4 - 13
892/00286	Surface Temperature Probe	4 - 4	892/01082	Powershift - Assembly Cradle	4 - 18
892/00293	Connector Pipe	4 - 6	892/01083	Powershift - Assembly tool, transfer gear	4 - 17
892/00294	Connector Pipe	4 - 6			
892/00298	Fluke Meter	4 - 4	892/01084	Powershift - Transfer gear, bearing assembly	4 - 17
892/00301	Flow Test Adapter	4 - 10			
892/00302	Flow Test Adapter	4 - 10	892/01085	Powershift - Seal fitting tool	4 - 17
892/00309	ARV Test Kit	4 - 7	926/15500	Rubber Spacer Blocks	4 - 3
892/00333	Heavy Duty Socket	4 - 11	992/04000	Torque Multiplier	4 - 12
892/00334	Ram Seal Fitting Tool	4 - 9	992/04800	Flange Spanner	4 - 12
892/00335	ARV Cartridge Removal Tool	4 - 7	992/07608	Bearing Adapter	4 - 10
892/00706	Test Probe	4 - 6, 4 - 7	992/07609	Bearing Adapter	4 - 10
892/00812	Drive Coupling Spanner	4 - 10	992/07610	Bearing Adapter	4 - 10
892/00817	Heavy Duty Socket	4 - 11	992/07611	Bearing Adapter	4 - 10
892/00818	Heavy Duty Socket	4 - 11	992/07612	Bearing Adapter	4 - 10
892/00819	Heavy Duty Socket	4 - 11	992/07613	Bearing Adapter	4 - 10
892/00822	Splined Bolt Socket	4 - 11	992/09100	Spool Clamp	4 - 8
892/00836	Lifting Wire Assembly	4 - 19	992/09200	Charging Tool	4 - 1
892/00842	Glass Lifter	4 - 2	992/09300	Ram Spanner	4 - 8
892/00843	Folding Stand	4 - 1	992/09400	Ram Spanner	4 - 8
892/00844	Long Knife	4 - 3	992/09500	Ram Spanner	4 - 8
892/00845	Cartridge Gun	4 - 1	992/09600	Ram Spanner	4 - 8
892/00846	Glass Extractor (Handles)	4 - 2	992/09700	Ram Spanner	4 - 8
892/00847	Nylon Spatula	4 - 3	992/09900	Ram Spanner	4 - 8
892/00848	Wire Starter	4 - 2	992/10000	Ram Spanner	4 - 8
892/00849	Braided Cutting Wire	4 - 3	992/12300	12V Mobile Oven	4 - 1
892/00881	Spool Seal Fitting Tool	4 - 7	992/12400	Static Oven - 2 Cartridge	4 - 2
892/00882	Alternator Pulley Socket	4 - 5	992/12600	Static Oven - 6 Cartridge	4 - 2
892/00891	Wheel Hub Seal - Fitting Tool	4 - 10	992/12800	Cut-Out Knife	4 - 2
892/00918	Setting Tool Kit	4 - 16	992/12801	"L" Blades	4 - 2
892/00920	Flow Test Adapter	4 - 10	993/55700	Direct Glazing Kit	5 - 1
892/00922	12.2" T/C Alignment Tool	4 - 10	993/59500	Impulse Extractor Adapter	4 - 11
892/00948	Charging Kit	4 - 9	993/68100	Slide Hammer Kit	4 - 3
892/00949	Pressure Gauge	4 - 9	993/69800	Seal Kit	4 - 6
892/00956	Timing Pin	4 - 19	993/70111	Breakback Torque Wrench	4 - 15
892/00964	Test Point (1/8BSP)	4 - 12	993/85700	Battery Tester	4 - 4
892/00965	Test Point (3/8BSP)	4 - 12	7210/0001	Dummy Plug	4 - 5
892/00966	Test Point (1/4BSP)	4 - 12	7210/0002	Wire Seal (1.4 - 2.2 mm dia.)	4 - 5
892/01016	Ram Seal Protection Sleeve 25 mm	4 - 9	7210/0003	Wire Seal (2.2 - 2.9 mm dia.)	4 - 5
892/01017	Ram Seal Protection Sleeve 30 mm	4 - 9	7212/0001	2 Way Socket Connector	4 - 5
892/01018	Ram Seal Protection Sleeve 40 mm	4 - 9	7212/0002	2 Way Pin Housing	4 - 5
892/01019	Ram Seal Protection Sleeve 50 mm	4 - 9	7212/0003	2 Way Socket Retainer	4 - 5
892/01020	Ram Seal Protection Sleeve 50 mm (slew ram)	4 - 9	7212/0004	2 Way Pin Retainer	4 - 5
			7213/0001	3 Way Socket Connector	4 - 5
892/01021	Ram Seal Protection Sleeve 60 mm	4 - 9	7213/0002	3 Way Pin Housing	4 - 5
892/01022	Ram Seal Protection Sleeve 60 mm (slew ram)	4 - 9	7213/0003	3 Way Socket Retainer	4 - 5
			7213/0004	3 Way Pin Retainer	4 - 5
892/01023	Ram Seal Protection Sleeve 65 mm	4 - 9	7213/0005	3 Way Socket Connector (DT)	4 - 5
892/01024	Ram Seal Protection Sleeve 70 mm	4 - 9	7213/0006	3 Way Pin Housing (DT)	4 - 5
892/01025	Ram Seal Protection Sleeve 75 mm	4 - 9	7213/0007	3 Way Socket Retainer (DT)	4 - 5
892/01026	Ram Seal Protection Sleeve 80 mm	4 - 9	7213/0008	3 Way Pin Retainer (DT)	4 - 5
892/01027	Piston Seal Assembly Tool	4 - 9	7214/0001	4 Way Socket Connector	4 - 5
892/01079	Ring Socket Spanner		7214/0002	4 Way Pin Housing	4 - 5
	Mainshaft setting ring	4 - 13	7214/0003	4 Way Socket Retainer	4 - 5
892/01080	Ring Socket Spanner		7214/0004	4 Way Pin Retainer	4 - 5
	Layshaft setting ring	4 - 13	7216/0001	6 Way Socket Connector	4 - 5
892/01077	Synchro Shuttle Gearbox Selector		7216/0002	6 Way Pin Housing	4 - 5
	Shaft Lock Screw	4 - 13	7216/0003	6 Way Socket Retainer	4 - 5
892/01078	Synchro Shuttle Gearbox		7216/0004	6 Way Pin Retainer	4 - 5
	Mainshaft Adjuster	4 - 13	7218/0001	8 Way Socket Connector	4 - 5
			7218/0002	8 Way Pin Housing	4 - 5

Service Tools Numerical List

7218/0003	8 Way Socket Retainer	4 - 5
7218/0004	8 Way Pin Retainer	4 - 5
7219/0001	10 Way Socket Connector	4 - 5
7219/0002	10 Way Pin Housing	4 - 5
7219/0003	10 Way Socket Retainer	4 - 5
7219/0004	10 Way Pin Retainer	4 - 5
7219/0005	14 Way Socket Connector	4 - 5
7219/0006	14 Way Pin Housing	4 - 5
7219/0007	14 Way Socket Retainer	4 - 5
7219/0008	14 Way Pin Retainer	4 - 5

The following parts are replacement items for kits and would normally be included in the kit numbers quoted on pages 1/3-1 and 1/3-2.

Service Tools Numerical List		Page No.
Replacement item for kit no. 892/00180		
892/00181		4 - 9
Replacement items for kit no. 892/00253		
892/00201	Replacement Gauge	4 - 6
892/00202	Replacement Gauge	4 - 6
892/00203	Replacement Gauge	4 - 6
892/00254	Replacement Hose	4 - 6
Replacement items for kit no. 892/00309		
892/00340	Test Block Body	4 - 7
892/00341	Setting Body	4 - 7
892/00343	Spanner	4 - 7
892/00345	Anti-Cavitation Lock Out Bung	4 - 7
993/68300	Adjusting Pin	4 - 7
Replacement items for kit no. 993/68100		
993/68101	Slide Hammer	4 - 3
993/68102	End Stops	4 - 3
993/68103	Adaptor - M20 x 5/8" UNF	4 - 3
993/68104	Adaptor - M20 x 1" UNF	4 - 3
993/68105	Adaptor - M20 x M20	4 - 3
993/68106	Adaptor - M20 x M24	4 - 3
993/68107	Bar - M20 x M20 X 800MM	4 - 3
993/68108	Adaptor - M20 x 7/8" UNF	4 - 3
993/68109	Adaptor - M20 x M12	4 - 3
993/68110	Adaptor - M20 x 5/8" UNF (Shoulder)	4 - 3
993/68111	Adaptor - M20 x 1/2" UNF	4 - 3

Service Tools (cont'd)

Section B - Body & Framework

826/01099	M6 x 16mm Rivet Nut
826/01101	M6 x 19mm Rivet Nut
826/01103	M8 x 18mm Rivet Nut
826/01102	M8 x 21mm Rivet Nut
826/01104	M10 x 23mm Rivet Nut
826/01105	M10 x 26mm Rivet Nut

Installation Tool Available from:
 Bollhoff Fastenings Ltd.
 Midacre
 The Willenhall Estate
 Rose Hill
 Willenhall
 West Midlands, WV13 2JW

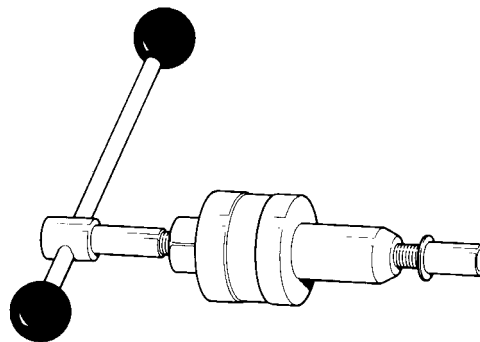

S261210

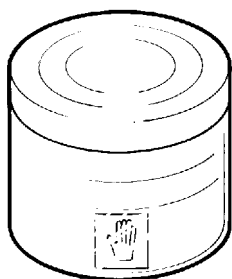

Hand Cleaner - special blend for the removal of polyurethane adhesives.

JCB part number - 4104/1310
 (454g; 1 lb tub)

S186240

Cartridge Gun - hand operated - essential for the application of sealants, polyurethane materials etc.

JCB part number - 892/00845

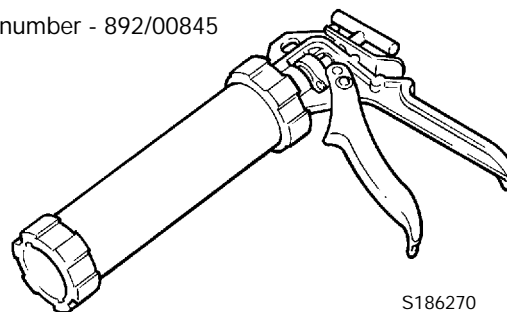

S186270

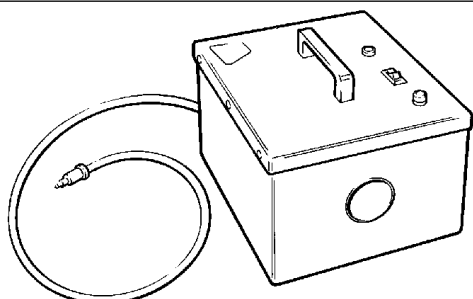

12V Mobile Oven - 1 cartridge capacity - required to pre-heat adhesive prior to use. It is fitted with a male plug (703/23201) which fits into a female socket (715/04300).

JCB part number - 992/12300

S186250

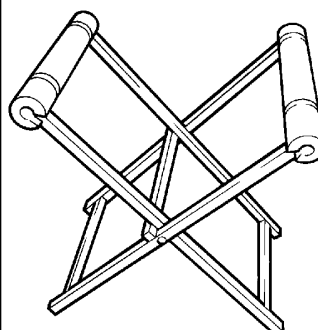

Folding Stand for Holding Glass - essential for preparing new glass prior to installation.

JCB part number - 892/00843

S186280

Service Tools (cont'd)

Section B - Body & Framework

240V Static Oven - available with 2 or 6 cartridge capacity - required to pre-heat adhesive prior to use. No plug supplied. Note: 110V models available upon request - contact JCB Technical Service.

JCB part number:

992/12400 - 2 Cartridge x 240V

992/12600 - 6 Cartridge x 240V

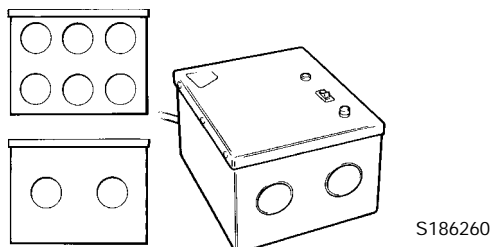

Glass Lifter - minimum 2 off - essential for glass installation, 2 required to handle large panes of glass. Ensure suction cups are protected from damage during storage.

JCB part number - 892/00842

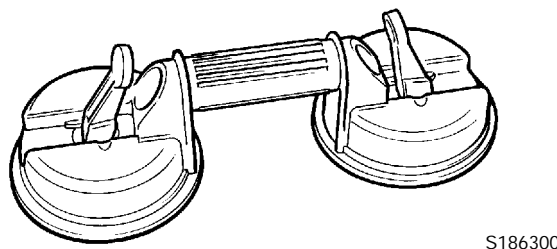

Wire Starter - used to access braided cutting wire (below) through original polyurethane seal.

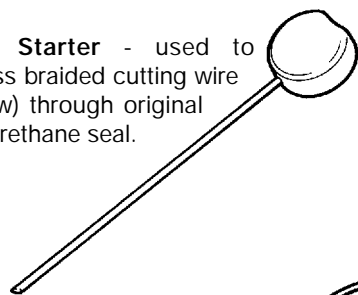

JCB part number - 892/00848

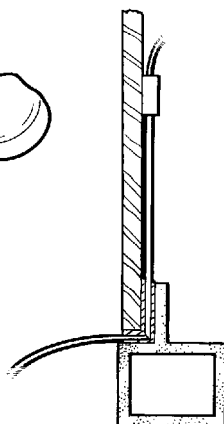

Cut-Out Knife - used to remove broken glass.

JCB part number - 992/12800

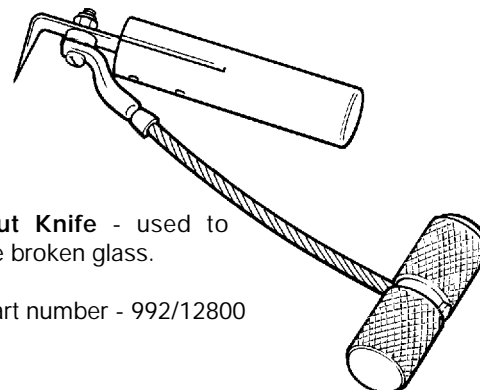

S186340

Glass Extractor (Handles) - used with braided cutting wire (below) to cut out broken glass.

JCB part number - 892/00846

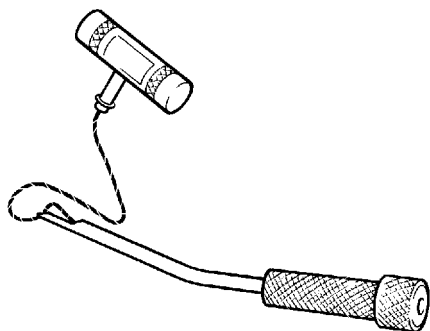

S186320

'L' Blades - 25 mm (1 in) cut - replacement blades for cut-out knife (above).

JCB part number - 992/12801 (unit quantity = 5 off)

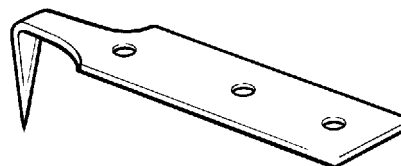

S186350

Service Tools (cont'd)

Section B - Body & Framework

Braided Cutting Wire - consumable heavy duty cut-out wire used with the glass extraction tool (above).

JCB part number - 892/00849
(approx 25 m length)

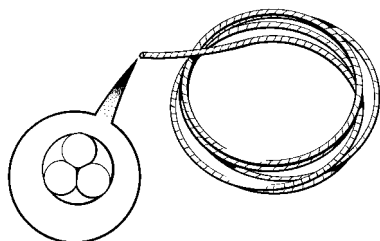

S186330

Long Knife - used to give extended reach for normally inaccessible areas.

JCB part number - 892/00844

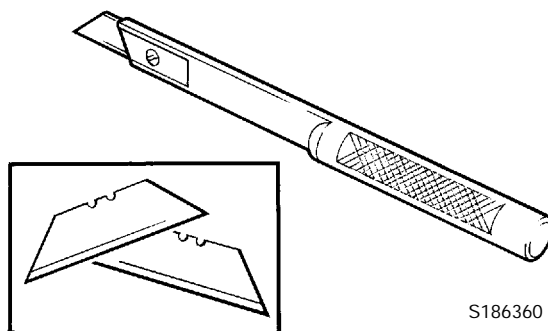

S186360

Nylon Spatula - general tool used for smoothing sealants - also used to re-install glass in rubber glazing because metal tools will chip the glass edge.

JCB part number - 892/00847

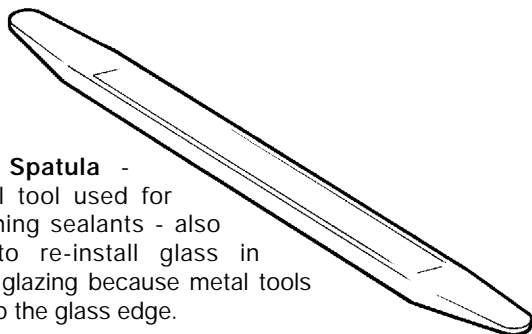

S186470

Rubber Spacer Blocks - used to provide the correct set clearance between glass edge and cab frame.

JCB part number - 926/15500
(unit quantity = 500 off)

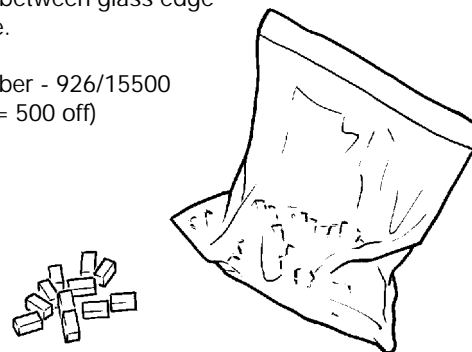

S186550

Slide Hammer Kit - 993/68100

- | | | | |
|--------------|--------------------------|---------------|-------------------------------------|
| 1 :993/68101 | Slide Hammer | 6 :993/68106 | Adaptor - M20 x M24 |
| 2 :993/68102 | End Stops | 7 :993/68107 | Bar - M20 x M20 X 800MM |
| 3 :993/68103 | Adaptor - M20 x 5/8" UNF | 8 :993/68108 | Adaptor - M20 x 7/8" UNF |
| 4 :993/68104 | Adaptor - M20 x 1" UNF | 9 :993/68109 | Adaptor - M20 x M12 |
| 5 :993/68105 | Adaptor - M20 x M20 | 10 :993/68110 | Adaptor - M20 x 5/8" UNF (Shoulder) |
| | | 11 :993/68111 | Adaptor - M20 x 1/2" UNF |

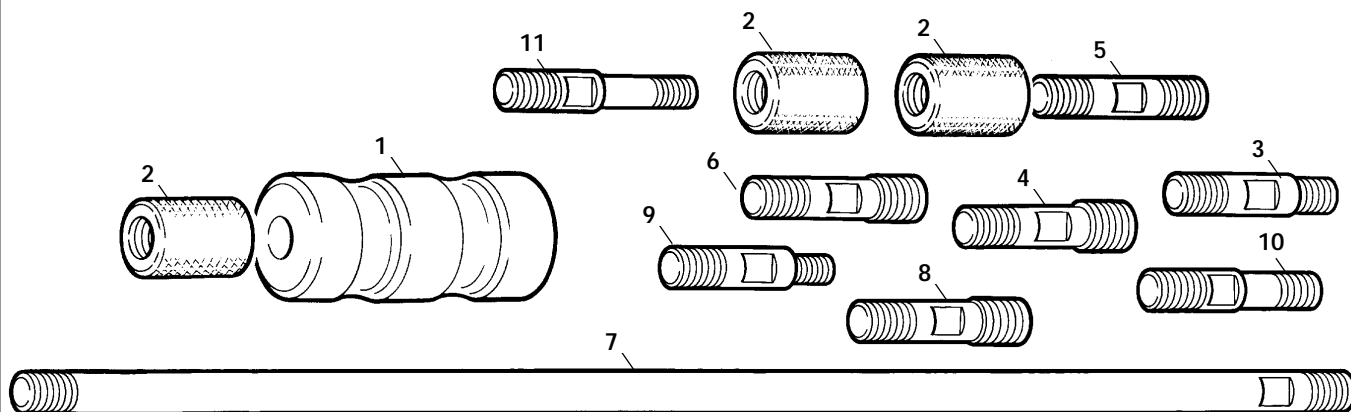

S196910

Service Tools (cont'd)

Section C - Electrics

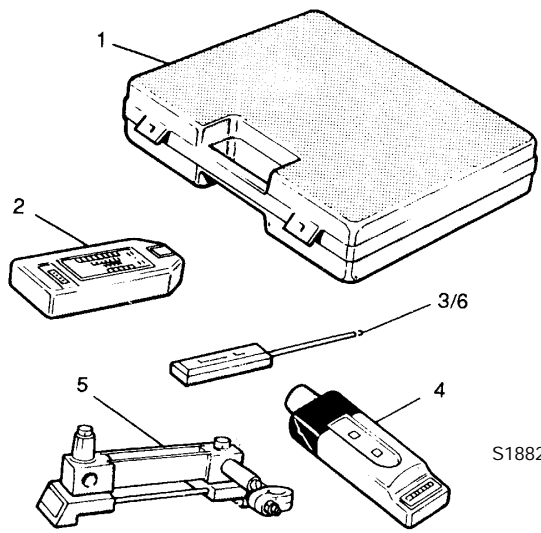

AVO Test Kit

1	892/00283	Tool Kit Case
2	892/00298	Fluke Meter 85
3	892/00286	Surface Temperature Probe
4	892/00284	Venture Microtach Digital Tachometer
5	892/00282	100 amp Shunt - open type
6	892/00285	Hydraulic Temperature Probe

S188231

993/85700 Battery Tester

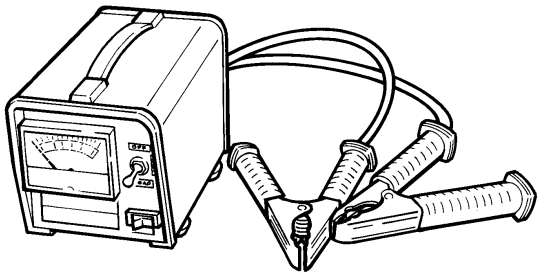

S239510

892/00882 Socket for Alternator Pulley Nut

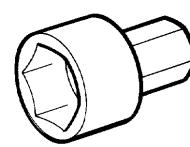

S216770

825/00410 15 mm Crowfoot Wrench
825/99833 Adapter

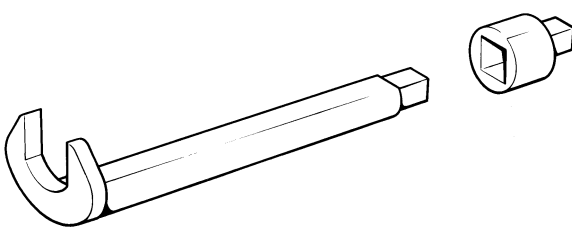

S216200

Service Tools (cont'd)

Section C - Electrics

1	Electrical Repair Kit	6A :7216/0002	6 Way Pin Housing
2A :7212/0002	2 Way Pin Housing	6B :7216/0004	6 Way Pin Retainer
2B :7212/0004	2 Way Pin Retainer	6C :7216/0003	6 Way Socket Retainer
2C :7212/0003	2 Way Socket Retainer	6D :7216/0001	6 Way Socket Connector
2D :7212/0001	2 Way Socket Connector	7A :7218/0002	8 Way Pin Housing
3A :7213/0002	3 Way Pin Housing	7B :7218/0004	8 Way Pin Retainer
3B :7213/0004	3 Way Pin Retainer	7C :7218/0003	8 Way Socket Retainer
3C :7213/0003	3 Way Socket Retainer	7D :7218/0001	8 Way Socket Connector
3D :7213/0001	3 Way Socket Connector	8A :7219/0002	10 Way Pin Housing
4A :7213/0006	3 Way Pin Housing (DT)	8B :7219/0004	10 Way Pin Retainer
4B :7213/0008	3 Way Pin Retainer (DT)	8C :7219/0003	10 Way Socket Retainer
4C :7213/0007	3 Way Socket Retainer (DT)	8D :7219/0001	10 Way Socket Connector
4D :7213/0005	3 Way Socket Connector (DT)	9A :7219/0006	14 Way Pin Housing
5A :7214/0002	4 Way Pin Housing	9B :7219/0008	14 Way Pin Retainer
5B :7214/0004	4 Way Pin Retainer	9C :7219/0007	14 Way Socket Retainer
5C :7214/0003	4 Way Socket Retainer	9D :7219/0005	14 Way Socket Connector
5D :7214/0001	4 Way Socket Connector	10 :7210/0001	Dummy Plug
		11 :7210/0002	Wire Seal (1.4 - 2.2 mm dia.)
		12 :7210/0003	Wire Seal (2.2 - 2.9 mm dia.)

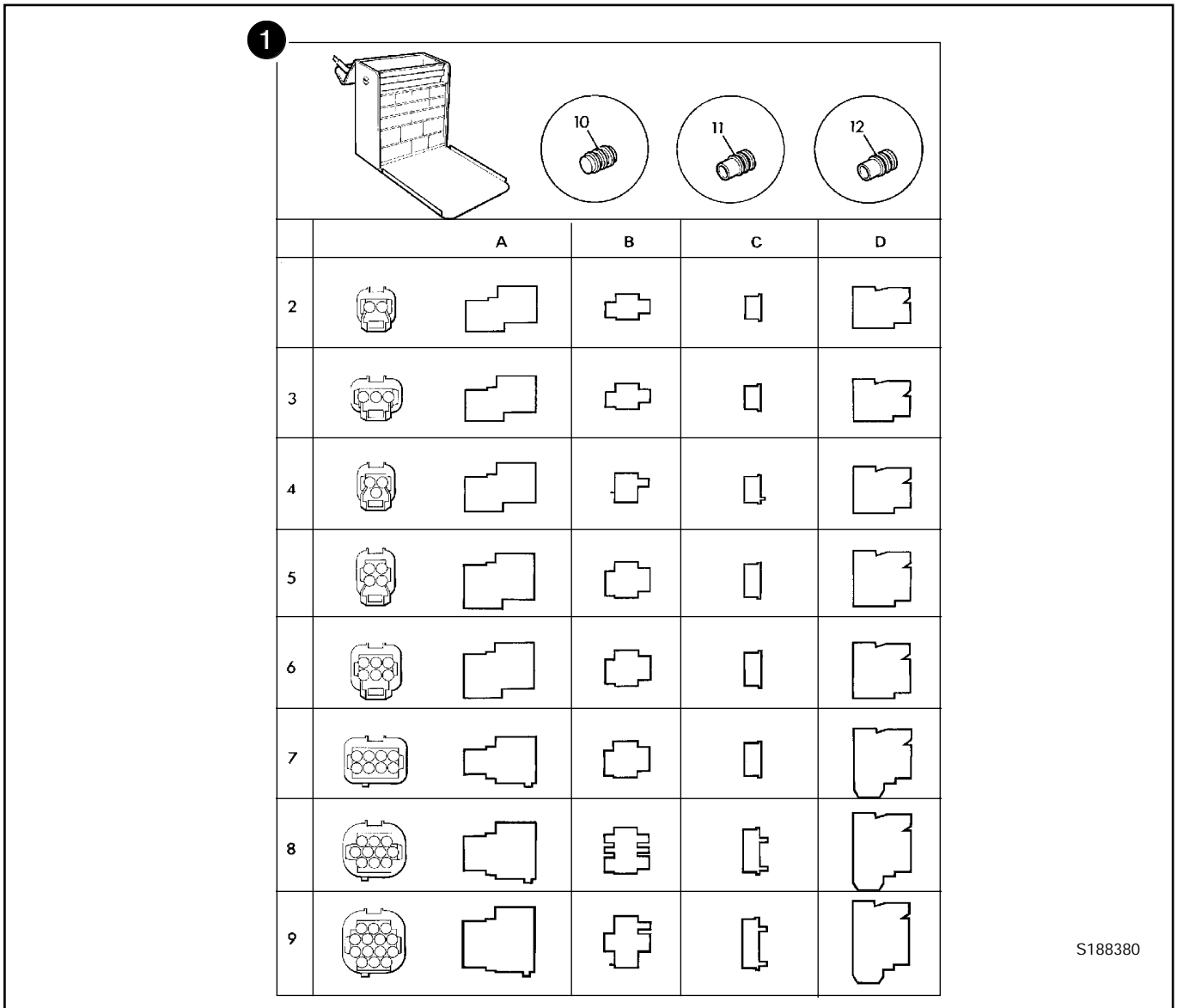

S188380

Service Tools (cont'd)

Section E - Hydraulics

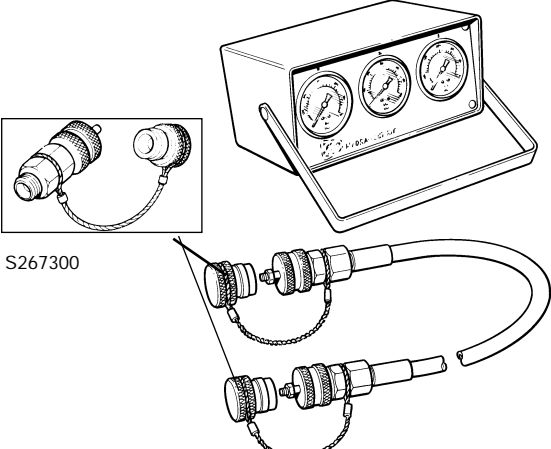

Hydraulic Circuit Pressure Test Kit

892/00253	Pressure Test Kit
:892/00201	Replacement Gauge 0-20 bar (0-300 lbf/in ²)
:892/00202	Replacement Gauge 0-40 bar (0-600 lbf/in ²)
:892/00203	Replacement Gauge 0-400 bar (0-6000 lbf/in ²)
:892/00254	Replacement Hose
993/69800	Seal Kit for 892/00254 (can also be used with probe 892/00706)
892/00706	Test Probe

S267300

S188121

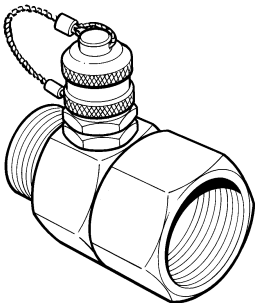

S188131

Pressure Test 'T' Adapters

892/00262	1/4 in M BSP x 1/4 in F BSP x Test Point
816/55038	3/8 in M BSP x 3/8 in F BSP x Test Point
816/55040	1/2 in M BSP x 1/2 in F BSP x Test Point
892/00263	5/8 in M BSP x 5/8 in F BSP x Test Point
892/00264	3/4 in M BSP x 3/4 in F BSP x Test Point
892/00265	1 in M BSP x 1 in F BSP x Test Point

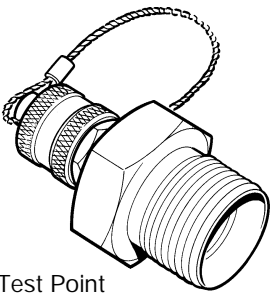

S200141

Pressure Test Adapters

892/00255	1/4 in BSP x Test Point
892/00256	3/8 in BSP x Test Point
892/00257	1/2 in BSP x Test Point
892/00258	5/8 in BSP x Test Point
816/15118	3/4 in BSP x Test Point
892/00259	1 in BSP x Test Point
892/00260	1.1/4 in BSP x Test Point
892/00261	5/8 in UNF x Test Point

Flow Test Equipment

892/00268	Flow Monitoring Unit
892/00269	Sensor Head 0 - 100 l/min (0 - 22 UK gal/min)
892/00293	Connector Pipe
892/00270	Load Valve
1406/0021	Bonded Washer
1604/0006	Adapter 3/4 in M x 3/4 in M BSP
1612/0006	Adapter 3/4 in F x 3/4 in M BSP
892/00271	Adapter 3/4 in F x 5/8 in M BSP
892/00272	Adapter 5/8 in F x 3/4 in M BSP
816/20008	Adapter 3/4 in F x 1/2 in M BSP
892/00275	Adapter 1/2 in F x 3/4 in M BSP
892/00276	Adapter 3/4 in F x 3/8 in M BSP
892/00277	Adapter 3/8 in F x 3/4 in M BSP
892/00273	Sensor Head 0 - 380 l/min
892/00294	Connector Pipe
1606/0015	Adapter 1.1/4 in M BSP x 1 in M BSP
892/00078	Connector 1 in F x 1 in F BSP
1604/0008	Adapter 1 in M x 1 in M BSP
1606/0012	Adapter 1 in M x 3/4 in M BSP
816/20013	Adapter 3/4 in F x 1 in M BSP

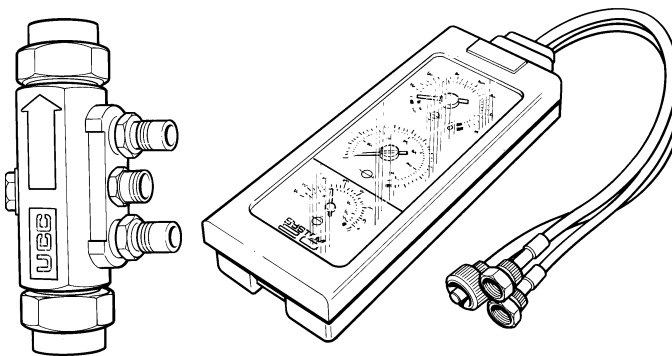

S188151

Service Tools (cont'd)

Section E - Hydraulics

892/00881 Valve Spool Seal Fitting Tool

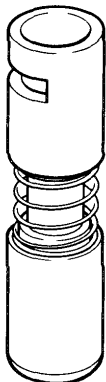

S261220

Hand Pump Equipment

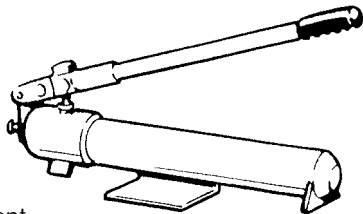

892/00223 Hand Pump
 892/00137 Micro-bore Hose 1/4 in BSP x 3 metres
 892/00274 Adapter 1/4 in M BSP x 3/8 in M BSP Taper
 892/00262 1/4 in M BSP x 1/4 in F BSP x Test Point
 892/00706 Test Probe
 892/00278 Gauge 0 - 40 bar (0 - 600 lbf/in²)
 892/00279 Gauge 0 - 400 bar (0 - 6000 lbf/in²)

S193850

Components for Valve Block A.R.V. Testing

For 4CX Variable Flow machines use 25/201103

892/00309	A.R.V. Pressure Test Kit
1 : 892/00340	Test Block Body
2 : 892/00341	Setting Body
3 : 993/68300	Adjusting Pin
4 : 892/00343	Spanner
5 : 892/00345	Anti-cavitation Lock Out Bung
6 : 892/00335	A.R.V. Cartridge Removal Tool

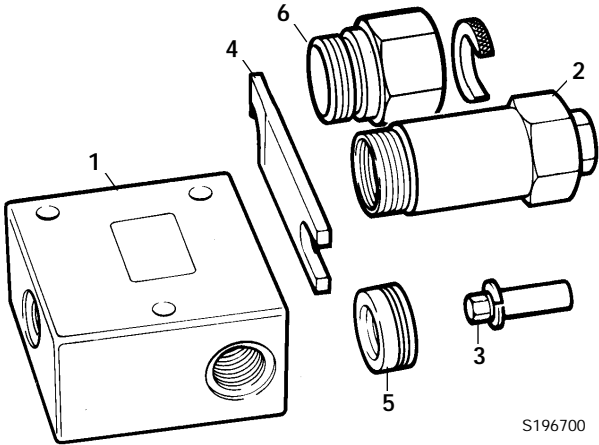

S196700

Bonded Washers

1406/0011	1/4 in. BSP
1406/0018	1/2 in. BSP
1406/0014	5/8 in. BSP
1406/0021	3/4 in. BSP
1406/0029	1.1/4 in. BSP



S188140

<p>Male Adapters - BSP x NPT (USA only)</p> <p>816/00439 3/8 in. x 1/4 in. 816/00440 1/2 in. x 1/4 in. 816/15007 3/8 in. x 3/8 in. 816/15008 1/2 in. x 3/8 in.</p>	<p>Male Adapters - BSP x BSP</p> <p>1606/0003 3/8 in. x 1/4 in. 1604/0003 3/8 in. x 3/8 in. 892/00071 3/8 in. x 3/8 in. taper 1606/0004 1/2 in. x 1/4 in. 1606/0007 1/2 in. x 3/8 in. 1604/0004 1/2 in. x 1/2 in. 1606/0017 5/8 in. x 1/2 in. 1606/0008 3/4 in. x 3/8 in. 1606/0009 3/4 in. x 1/2 in. 1604/0006 3/4 in. x 3/4 in. 1606/0012 3/4 in. x 1 in. 1606/0014 3/4 in. x 1.1/4 in. 1606/0015 1 in. x 1.1/4 in.</p>
---	---

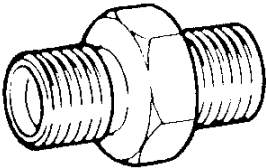

S193860

Service Tools (cont'd)

Section E - Hydraulics

Female Cone Blanking Plug

- 892/00055 1/4 in. BSP
- 892/00056 3/8 in. BSP
- 892/00057 1/2 in. BSP
- 892/00058 5/8 in. BSP
- 892/00059 3/4 in. BSP
- 892/00060 1 in. BSP

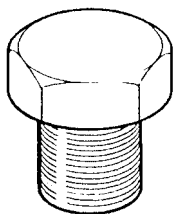

S193870

Male Cone Blanking Cap

- 816/00294 1/4 in. BSP
- 816/00189 3/8 in. BSP
- 816/00190 1/2 in. BSP
- 816/00197 5/8 in. BSP
- 816/00196 3/4 in. BSP
- 816/00193 1 in. BSP

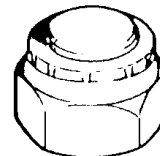

S193880

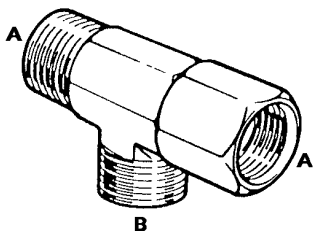

S193890

- 892/00047 3/8 in. BSP (A) x 1/4 in. BSP (B)
- 892/00048 1/2 in. BSP (A) x 1/4 in. BSP (B)
- 892/00049 5/8 in. BSP (A) x 1/4 in. BSP (B)
- 816/50043 3/4 in. BSP (A) x 1/4 in. BSP (B)
- 892/00051 1 in. BSP (A) x 1/4 in. BSP (B)
- 816/50005 1/2 in. BSP (A) x 1/2 in. BSP (B)
- 816/60096 3/4 in. BSP (A) x 3/4 in. BSP (B)
- 816/00017 1 in. BSP (A) x 1 in. BSP (B)

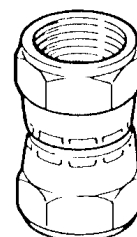

S193900

Female Connectors

- 892/00074 3/8 in. BSP x 3/8 in. BSP
- 892/00075 1/2 in. BSP x 1/2 in. BSP
- 892/00076 5/8 in. BSP x 5/8 in. BSP
- 892/00077 3/4 in. BSP x 3/4 in. BSP

- 992/09100 Excavator Spool Clamp
- 892/00011 Spool Clamp

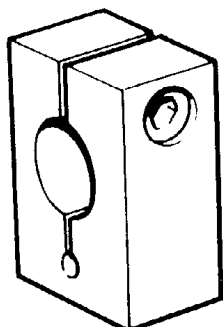

S216210

Hexagon Spanners for Ram Pistons and End Caps

- 992/09300 55mm A/F
- 992/09400 65mm A/F
- 992/09500 75mm A/F
- 992/09600 85mm A/F
- 992/09700 95mm A/F
- 992/09900 115mm A/F
- 992/10000 125mm A/F

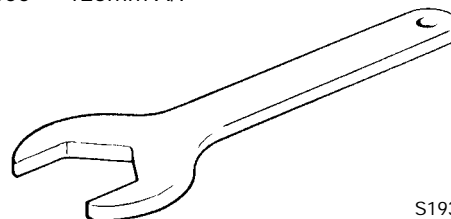

S193930

Service Tools (cont'd)

Section E - Hydraulics

S216230

892/00180 Seal Fitting Tool for fitting 'O' ring and kin ring to Hydraulic Steer Unit

892/00181 Replacement Plastic Boss

892/01027 Piston Seal Assembly Tool

338500

S216250

892/00334 Ram Seal Fitting Tool

S338410

Ram Seal Protection Sleeves

- 892/01016 For 25 mm Rod Diameter
- 892/01017 For 30 mm Rod Diameter
- 892/01018 For 40 mm Rod Diameter
- 892/01019 For 50 mm Rod Diameter
- 892/01020 For 50 mm Rod Diameter (slew ram)
- 892/01021 For 60 mm Rod Diameter
- 892/01022 For 60 mm Rod Diameter (slew ram)
- 892/01023 For 65 mm Rod Diameter
- 892/01024 For 70 mm Rod Diameter
- 892/01025 For 75 mm Rod Diameter
- 892/01026 For 80 mm Rod Diameter
- 892/00167 For 90 mm Rod Diameter

S308271

892/00948 Charging Kit (without gauge)

892/00949 Gauge

Service Tools (cont'd)

Section F - Transmission

892/00812 Drive Coupling Spanner for front axle and gearbox yoke couplings

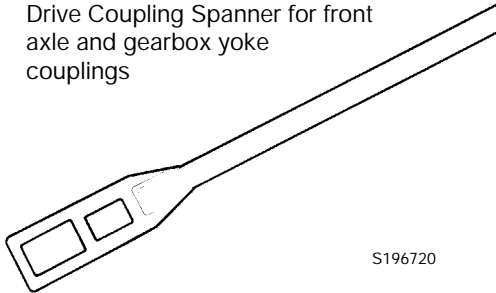

S196720

A 892/00920 Flow Test Adapter
 B 892/00301 Flow Test Adapter
 C 892/00302 Flow Test Adapter

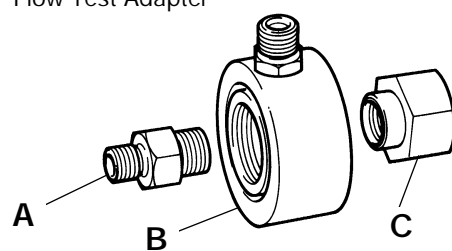

S266880

892/00179 Bearing Press (use with appropriate adapters)

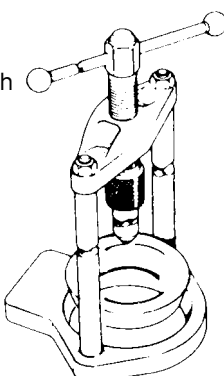

S188200

992/07608 Bearing Adapter
 992/07609 Bearing Adapter
 992/07610 Bearing Adapter
 992/07611 Bearing Adapter
 992/07612 Bearing Adapter
 992/07613 Bearing Adapter



S188160

892/00922 12.2" Torque Converter Alignment Tool

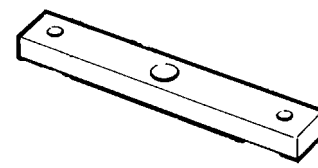

S267260

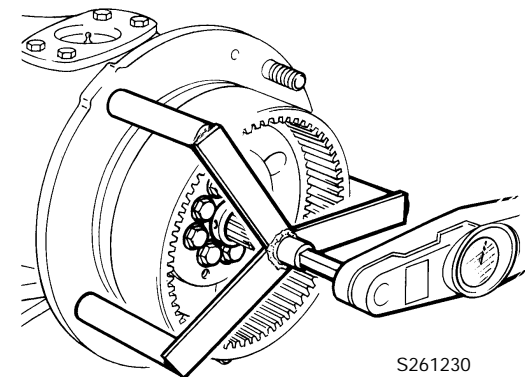

S261230

Torque Measuring Tool for Wheel Hub Seals

Manufacture locally, procedures in this manual show checking the wheel hub seal using a rolling force. However, the torque can be measured using above locally manufactured tool.

Bearing rolling torque is 12 to 22 Nm (9 to 16 lbf ft) excluding seal drag. Maximum permissible including seal drag is 40 Nm (29.5 lbf ft).

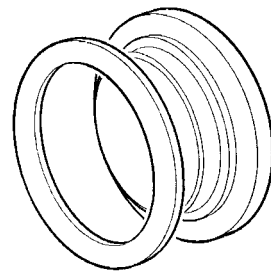

892/00891

Fitting Tool Assembly for Wheel Hub Seals

S227760