

# **EUROTECH CURSOR**

# **EUROSTAR CURSOR**

## **REPAIR MANUAL**

**IVECO**

This publication describes the characteristics, data and correct methods for repair operations on each component of the vehicle.

If the instructions provided are followed and the specified equipment is used, correct repair operations in the allotted time will be guaranteed, and the operators will also be protected against possible accidents.

Before any repair is commenced, ensure that all normal safety precautions are observed.

All items specified by the safety regulations-goggles, helmet gloves, boots-should be checked and worn.

All machining, lifting and conveying equipment should be inspected before use.

The data contained in this publication was correct at the time of going to press but, owing to possible modifications made by the Manufacturer for reasons of a technical or commercial nature or for adaptation to the legal requirements of different countries, some changes may have occurred.

Full or partial reproduction of the text and illustrations prohibited.

Publication Edited by:  
IVECO S.p.A.  
T.C.O. - B.U. Customer Service  
Lungo Stura Lazio 49  
10156 Torino (Italy)

Print **603.43.391** - 1st Ed. - 1999



Publication Produced by:  
SATIZ S.p.A.  
Pubblicazioni Tecniche Iveco  
c/o Iveco - Lungo Stura Lazio 49  
10156 Torino

## NOTE

This manual is divided into several sections.

Section numbers are listed on the index page to be found at the beginning of each repair manual.

Each section deals generally with one of the main assemblies (engine, transmission etc.)

Each section deals with the following topics:

Specifications and data; Tightening torques; Special tools; Troubleshooting (fault diagnosis); Component removal/refitting; Repair operations.

This manual provides graphs and symbols instead of description of parts, operations or operating procedures (see next page).

Example

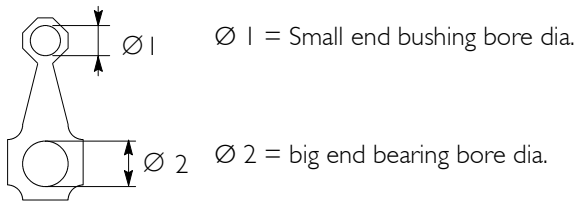

Tighten to specified torque  
Tighten to specified torque +  
angular value

You will also notice that titles and subtitles of operations to be carried out are marked with a 6-figure number, the **Product Code** corresponding codes provided in the REPAIR BASE TIME SCHEDULES and in FAILURE CODES.

Below you will find the explanation of each "NUMERICAL CODE" component.



Figures one and two identify the PRODUCT as part of the vehicle.

Example:

- Product    50 = Chassis;
- Product    52 = Axles;
- Product    53 = Gearbox etc.

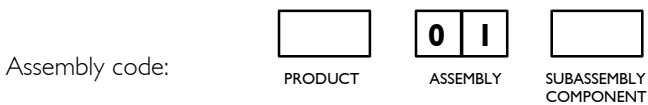

Figures three and four identify the ASSEMBLY within the PRODUCT

Example:

- Product    50 = Chassis;
- Assembly    01 = Chassis frame;
- Assembly    02 = Antitelescoping bumper etc .

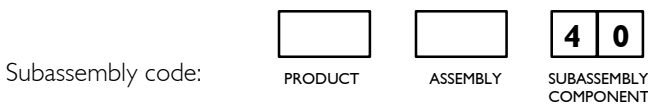





































Figures five and six identify THE SUBASSEMBLY and a Component of an Assembly within a PRODUCT.

Example:

- Product    50 = Chassis;
- Assembly    01 = Chassis frame;
- Subassembly 40 = Chassis cross members etc.

## Graphs and symbols

	Disconnection Disconnect		Suction, intake
	Reconnection Reconnect		Exhaust discharge
	Disassembly Dismantling		Operation
	Assembly		Compression ratio
	Tightening torque		Tolerance Load unbalance
	Tightening torque Tightening torque + angular value		Rolling torque
	Notching or caulking		Part replacement Original spare parts
	Adjustment Regulation		Rotation
	Warning Note		Angle Angle value
	Visual check Fitting position check		Preloading
	Measurement Dimension reading Check		Number of revolutions
	Tooling		Temperature
	Machining surface Finished part		Pressure
	Interference Force fitting		Oversized Less than... Maximum, peak
	Thickness Clearance, play, backlash		Undersized Less than... Minimum
	Lubricate Moisten Grease		Selection Class Oversizing
	Sealant Adhesive		Temperature below $< 0^{\circ} \text{C}$ Cold Winter
	Air bleeding		Temperature over $0^{\circ} \text{C}$ Warm Summer

# INDEX







	Section
General	<b>1</b>
Engine	<b>2</b>
Clutch	<b>3</b>
Transmission*	<b>4</b>
Intarder - ZF hydraulic retarder	<b>5</b>
Propeller shafts	<b>6</b>
Rear axles	<b>7</b>
Axles	<b>8</b>
Suspension	<b>9</b>
Wheels and tyres	<b>10</b>
Steering system	<b>11</b>
Hydraulic system - Brakes	<b>12</b>
Scheduled Maintenance	<b>13</b>

**SECTION I****General**

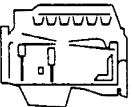
	Page
COMPOSITION OF THE MODELS	3
P.I.C. CODE NUMBER	7
<input type="checkbox"/> Vehicle Identification Data (EUROTECH)	11
<input type="checkbox"/> Vehicle Identification Data (EUROSTAR)	12
FILLING UP	13
<input type="checkbox"/> International designations of lubricants and fluids	14

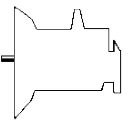
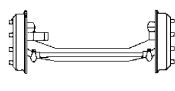
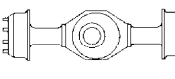

**COMPOSITION OF MODELS**





ASSEMBLIES		CHASSIS CABS - 4x2 MODELS																
		MP190E39	MP190EE39/P	LD190E39/P	MP190E39/FP-CM	LD190E39/FP-CM	MP190E39/FP-CT	MP190E39/FP-GV	LD190E39/FP-GV	MP190E43	MP190E43/P	LD190E43/P	MP190E43/FP-CM	LD190E43/FP-CM	MP190E43/FP-CT	MP190E43/FP-GV	LD190E43/FP-GV	
	F3AE0681D	○	○	○	○	○	○	○	○									
	F3AE0618E									○	○	○	○	○	○	○	○	
	Single disc 17"	○	○	○	○	○	○	○	○	○	○	○	○	○	○	○	○	
	ZF 16S 151	○	○	○	○	○	○	○	○	○	○	○	○	○	○	○	○	
	ZF 16S 181	○		○		○		○	○	○		○		○		○	○	
	ZF 16S 221																	
	EuroTronic 1800 - 12 AS 2301		○	○	○	○	○	○		○	○	○	○	○	○	○	○	
	FRONT AXLE: 5876/4 (F 8021)	⊗	⊗	⊗	⊗	⊗				⊗	⊗	⊗	⊗	⊗				
	5876/5 (F 8021)						◆	◆	◆						◆	◆	◆	
	5876 (F 8021)*																	
	ADDED AXLE: Steering central 5876/2 (F 8021)																	
	Rigid rear 55080 (N 8071)																	
	Rigid rear 56082 (N 9171)																	
Steering rear 57080 (N 8072)																		
	MERITOR U 177 E	○	○	○	○	○	○	○	○	○	○	○	○	○	○	○	○	
	MERITOR MS 13-175	○	○	○	○	○	○	○	○	○	○	○	○	○	○	○	○	
	MERITOR RT 160 E - RT160E/1																	
	ZF 8098	○	○	○	○	○	○	○	○	○	○	○	○	○	○	○	○	
	FRONT MECHANICAL																	
	□ Front Parabolic	○	○	○						○	○	○						
	□ Rear Parabolic	○								○								
□ Rear cantilever Parabolic																		
	PNEUMATIC																	
	Front				◇	◇	□	□	□				◇	◇	□	□	□	
	Rear		○	○	○	○	○	○		○	○	○	○	○	○	○	○	
Added axle																		

- T = 4x2 tractor
- TX = 6x2 C tractor (central added axle cannot be lifted)
- TY = 6x2 P tractor (rear added axle can be lifted)
- TN = 6x2 vehicles with mechanical rear suspensions and raisable rigid rear added axle
- TZ = 6x4 tractor (bogie rear axle)
- P = 4x2 – 6x2P – 6x2C vehicles with air suspension on rear axle and 6x2P vehicles with rigid rear axle that can be lifted with single wheels
- PT = 6x2P vehicles with air suspension on rear axle and rigid rear added axle that can be lifted with twin wheels
- PS = 6x2P vehicles with air suspension on rear axle and on steering rear added axle that can be lifted with single wheels
- FP = 4x2 – 6x4 – 6x2P – 6x2C vehicles with front and rear air suspensions
- FS = 6x2P vehicles with front and rear air suspensions, steering rear added axle can be lifted with single wheels
- 4x2 = Vehicles with two axles with rear driving axle
- 6x2P = Vehicles with three axles with rear driving axle and rear added third axle that can be lifted
- 6x2C = Vehicles with three axles with rear driving axle and central added third axle that cannot be lifted
- 6x4 = Vehicles with three axles with two rear driving axles (in tandem)
- CM = Movable Boxes
- GV = High Volumes
- HM = Heavy Mission
- CT = Chassis cab with lowered chassis frame
- HR = Hub Reduction

\* = Upon request axle with drum brakes    ⊗ = With brake pliers assembly at 57° without parking brake    ◇ = With long and cross bars  
 ◆ = With brake pliers assembly at 0°    □ = With parabolic leaf springs

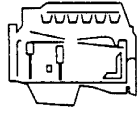

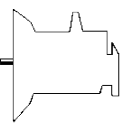
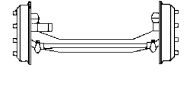
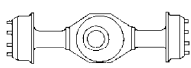

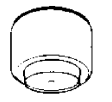



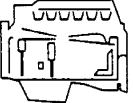

**COMPOSITION OF MODELS**

ASSEMBLIES		MP260E39Y/P	LD260E39Y/P	MP260E39Y/PS	LD260E39Y/PS	MP260E39Y/FP-CM	LD260E39Y/FP-CM	MP260E39Y/FS-CM	LD260E39Y/FS-CM	MP260E39Y/FP-GV	LD260E39Y/FP-GV	MP260E39Y/TN	MP260E39Y/FS-GV	LD260E39Y/FS-GV	MP260E39Y/PT	LD260E39Y/PT	MP260E43Y/P	LD260E43Y/P	MP260E43Y/PF	LD260E43Y/PS	MP260E43Y/FP-CM	LD260E43Y/FP-CM	MP260E43Y/FS-CM	LD260E43Y/FS-CM	MP260E43Y/FP-GV	LD260E43Y/FP-GV	MP260E43Y/TN	MP260E43Y/FS-GV	MP260E43Y/PT	LD260E43Y/PT		
	F3AE0681D	○	○	○	○	○	○	○	○	○	○	○	○	○	○	○																
	F3AE0618E																○	○	○	○	○	○	○	○	○	○	○	○	○	○	○	○
	Single disc 17"	○	○	○	○	○	○	○	○	○	○	○	○	○	○	○	○	○	○	○	○	○	○	○	○	○	○	○	○	○	○	○
	ZF 16S 151	○	○	○	○	○	○	○	○	○	○	○	○	○	○	○	○	○	○	○	○	○	○	○	○	○	○	○	○	○	○	○
	ZF 16S 181			○	○			○		○	○	○	○	○	○	○					○											
	ZF 16S 221																															
	EuroTronic 1800 - 12 AS 2301	○	○	○	○	○	○	○	○	○	○	○	○	○	○	○	○	○	○	○	○	○	○	○	○	○	○	○	○	○	○	○
	FRONT AXLE: 5876/4 (F 8021)	⊗	⊗			⊗	⊗	⊗	⊗								⊗	⊗			⊗	⊗	⊗	⊗								
	5876/5 (F 8021)			◆	◆					◆	◆	◆	◆	◆	◆	◆			◆	◆						◆	◆	◆	◆	◆	◆	◆
	5876 (F 8021)*																															
	ADDED AXLE: Steering central 5876/2 (F 8021)																															
	Rigid rear 55080 (N 8071)	○	○			○	○			○	○											○	○									
	Rigid rear 56082 (N 9171)												○	○																		
Steering rear 57080 (N 8072)			○	○				○	○																							
	MERITOR U 177 E	○	○	○	○	○	○	○	○	○	○	○	○	○	○	○	○	○	○	○	○	○	○	○	○	○	○	○	○	○	○	○
	MERITOR MS 13-175	○	○	○	○	○	○	○	○	○	○	○	○	○	○	○	○	○	○	○	○	○	○	○	○	○	○	○	○	○	○	○
	MERITOR RT 160 E - RT160E/I																															
	ZF 8098	○	○	○	○	○	○	○	○	○	○	○	○	○	○	○	○	○	○	○	○	○	○	○	○	○	○	○	○	○	○	○
	FRONT MECHANICAL																															
	□ Front Parabolic	○	○	○	○							○																				
	□ Rear Parabolic																															
	□ Rear cantilever Parabolic											○																				
	PNEUMATIC Front					◇	◇	◇	◇	□	□											◇	◇	◇	◇	□	□					
	Rear	○	○	○	○	○	○	○	○	○	○		○	○	○	○	○	○	○	○	○	○	○	○	○	○	○	○	○	○	○	
	Added axle	○	○	○	○	○	○	○	○	○	○		○	○	○	○	○	○	○	○	○	○	○	○	○	○	○	○	○	○	○	

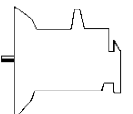
- T = 4x2 tractor
- TX = 6x2 C tractor (central added axle cannot be lifted)
- TY = 6x2 P tractor (rear added axle can be lifted)
- TN = 6x2 vehicles with mechanical rear suspensions and raisable rigid rear added axle
- TZ = 6x4 tractor (bogie rear axle)
- P = 4x2 – 6x2P – 6x2C vehicles with air suspension on rear axle and 6x2P vehicles with rigid rear axle that can be lifted with single wheels
- PT = 6x2P vehicles with air suspension on rear axle and rigid rear added axle that can be lifted with twin wheels
- PS = 6x2P vehicles with air suspension on rear axle and on steering rear added axle that can be lifted with single wheels
- FP = 4x2 – 6x4 – 6x2P – 6x2C vehicles with front and rear air suspensions
- FS = 6x2P vehicles with front and rear air suspensions, steering rear added axle can be lifted with single wheels
- 4x2 = Vehicles with two axles with rear driving axle
- 6x2P = Vehicles with three axles with rear driving axle and rear added third axle that can be lifted
- 6x2C = Vehicles with three axles with rear driving axle and central added third axle that cannot be lifted
- 6x4 = Vehicles with three axles with two rear driving axles (in tandem)
- CM = Movable Boxes
- GV = High Volumes
- HM = Heavy Mission
- CT = Chassis cab with lowered chassis frame
- HR = Hub Reduction

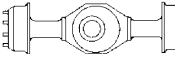
\* = Upon request axle with drum brakes     ⊗ = With brake pliers assembly at 57° without parking brake     ◇ = With long and cross bars  
 ◆ = With brake pliers assembly at 0°     □ = With parabolic leaf springs







**COMPOSITION OF MODELS**

MODELS		CHASSIS CABS 6x4				TRACTOR 6x4																				
		MP260E39Z-HM	LD260E39Z/P-HM	MP260E43Z-HM	LD260E43Z/P-HM	MP440E39T	MP440E39T(HR)	MP440E39T/P	LD440E39T/P	MP440E39T/P-HM	LD440E39T/P-HM	MP440E39T/FP-CT	MP440E39T/FP-LT	LD440E39T/FP-LT	MP440E43T	MP440E43T(HR)	MP440E43T-HM	MP440E43T/P	LD440E43T/P	MP440E43T/P-HM	LD440E43T/P-HM	MP440E43T/FP-CT	MP440E43T/FP-LT	LD440E43T/FP-LT		
	F3AE0681D	○	○			○	○	○	○	○	○	○	○	○												
	F3AE0618E														○	○	○	○	○	○	○	○	○	○	○	○
	Single disc 17"	○	○	○	○	○	○	○	○	○	○	○	○	○	○	○	○	○	○	○	○	○	○	○	○	
	ZF I6S 151					○	○	○	○	○	○	○	○	○	○	○	○	○	○	○	○	○	○	○	○	
	ZF I6S 181	○	○	○	○	○	○	○	○	○	○	○	○	○	○	○	○	○	○	○	○	○	○	○	○	
	ZF I6S 221																									
	EuroTronic 1800 - 12 AS 2301			○	○				○	○	○	○	○	○			○	○	○	○	○	○	○	○	○	
	FRONT AXLE: 5876/4 (F 8021)	⊗	⊗	⊗	⊗	⊗	⊗	⊗	⊗	⊗				⊗	⊗	⊗	⊗	⊗	⊗	⊗	⊗	⊗	⊗	⊗		
	5876/5 (F 8021)											◆	◆	◆									◆	◆	◆	
	5876 (F 8021)*																									
	ADDED AXLE:																									
	Steering central 5876/2 (F 8021)																									
	Rigid rear 55080 (N 8071)																									
	Rigid rear 56082 (N 9171)																									
Steering rear 57080 (N 8072)																										
	MERITOR U 177 E					○		○	○	○	○	○	○	○		○	○	○	○	○	○	○	○	○	○	
	MERITOR MS 13-175					○		○	○	○	○	○	○	○		○	○	○	○	○	○	○	○	○	○	
	MERITOR RT 160 E - RT160E/1	○	○	○	○																					
	451391 HR						○									○										
	ZF 8098	○	○	○	○	○	○	○	○	○	○	○	○	○	○	○	○	○	○	○	○	○	○	○	○	
	FRONT MECHANICAL																									
	□ Front Parabolic	○	○	○	○	○	○	○	○	○					○	○	○	○	○	○	○	○	○	○	○	
	□ Rear Parabolic			○											○	○	○									
□ Rear cantilever Parabolic	○		○																							
	PNEUMATIC																									
	Front											□	□	□									□	□	□	
	Rear		○		○			○	○	○	○	○	○	○				○	○	○	○	○	○	○	○	
	Added axle																									

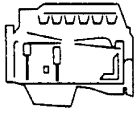
- T = 4x2 tractor
- TX = 6x2 C tractor (central added axle cannot be lifted)
- TY = 6x2 P tractor (rear added axle can be lifted)
- TN = 6x2 vehicles with mechanical rear suspensions and raisable rigid rear added axle
- TZ = 6x4 tractor (bogie rear axle)
- P = 4x2 – 6x2P – 6x2C vehicles with air suspension on rear axle and 6x2P vehicles with rigid rear axle that can be lifted with single wheels
- PT = 6x2P vehicles with air suspension on rear axle and rigid rear added axle that can be lifted with twin wheels
- PS = 6x2P vehicles with air suspension on rear axle and on steering rear added axle that can be lifted with single wheels
- FP = 4x2 – 6x4 – 6x2P – 6x2C vehicles with front and rear air suspensions
- FS = 6x2P vehicles with front and rear air suspensions, steering rear added axle can be lifted with single wheels
- 4x2 = Vehicles with two axles with rear driving axle
- 6x2P = Vehicles with three axles with rear driving axle and rear added third axle that can be lifted
- 6x2C = Vehicles with three axles with rear driving axle and central added third axle that cannot be lifted
- 6x4 = Vehicles with three axles with two rear driving axles (in tandem)
- CM = Movable Boxes
- GV = High Volumes
- CT = Chassis cab with lowered chassis frame
- HR = Hub Reduction

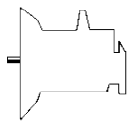
\* = Upon request axle with drum brakes    ⊗ = With brake pliers assembly at 57° without parking brake    ◇ = With long and cross bars  
 ◆ = With brake pliers assembly at 0°    □ = With parabolic leaf springs

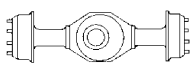
## COMPOSITION OF MODELS

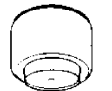
TRACTORS - MODELS		6x2 C				6x4			
		MP440E39TX/P	LD440E39TX/P	MP440E43TX/P	LD440E43TX/P	MP260E39Z-HM	LD440E39TZ/P-HM	MP440E43TZ-HM	LD440E43TZ/P-HM
	F3AE0681D	<input type="checkbox"/>	<input type="checkbox"/>			<input type="checkbox"/>	<input type="checkbox"/>		
	F3AE0618E			<input type="checkbox"/>	<input type="checkbox"/>			<input type="checkbox"/>	<input type="checkbox"/>
	Single disc 17"	<input type="checkbox"/>	<input type="checkbox"/>	<input type="checkbox"/>	<input type="checkbox"/>	<input type="checkbox"/>	<input type="checkbox"/>	<input type="checkbox"/>	<input type="checkbox"/>
	ZF 16S 151	<input type="checkbox"/>	<input type="checkbox"/>	<input type="checkbox"/>	<input type="checkbox"/>				
	ZF 16S 181	<input type="checkbox"/>	<input type="checkbox"/>	<input type="checkbox"/>	<input type="checkbox"/>				
	ZF 16S 221					<input type="checkbox"/>	<input type="checkbox"/>	<input type="checkbox"/>	<input type="checkbox"/>
	EuroTronic 1800 - 12 AS 2301	<input type="checkbox"/>	<input type="checkbox"/>	<input type="checkbox"/>	<input type="checkbox"/>		<input type="checkbox"/>		<input type="checkbox"/>
	FRONT AXLE:								
	5876/4 (F 8021)	<input checked="" type="checkbox"/>	<input checked="" type="checkbox"/>	<input checked="" type="checkbox"/>	<input checked="" type="checkbox"/>	<input checked="" type="checkbox"/>	<input checked="" type="checkbox"/>	<input checked="" type="checkbox"/>	<input checked="" type="checkbox"/>
	5876/5 (F 8021)								
	5876 (F 8021)*					<input type="checkbox"/>	<input type="checkbox"/>	<input type="checkbox"/>	<input type="checkbox"/>
	ADDED AXLE:								
	Steering central		<input type="checkbox"/>	<input type="checkbox"/>	<input type="checkbox"/>				
	Rigid rear								
Rigid rear									
Steering rear									
	MERITOR U 177 E	<input type="checkbox"/>	<input type="checkbox"/>	<input type="checkbox"/>	<input type="checkbox"/>				
	MERITOR MS 13-175	<input type="checkbox"/>	<input type="checkbox"/>	<input type="checkbox"/>	<input type="checkbox"/>				
	MERITOR RT 160 E - RT160E/I					<input type="checkbox"/>	<input type="checkbox"/>	<input type="checkbox"/>	<input type="checkbox"/>
	ZF 8098	<input type="checkbox"/>	<input type="checkbox"/>	<input type="checkbox"/>	<input type="checkbox"/>	<input type="checkbox"/>	<input type="checkbox"/>	<input type="checkbox"/>	
	FRONT MECHANICAL								
	<input type="checkbox"/> Front		Parabolic	<input type="checkbox"/>	<input type="checkbox"/>	<input type="checkbox"/>	<input type="checkbox"/>	<input type="checkbox"/>	<input type="checkbox"/>
	<input type="checkbox"/> Rear		Parabolic						
<input type="checkbox"/> Rear cantilever		Parabolic				<input type="checkbox"/>	<input type="checkbox"/>		
	PNEUMATIC								
	Front								
	Rear	<input type="checkbox"/>	<input type="checkbox"/>	<input type="checkbox"/>	<input type="checkbox"/>		<input type="checkbox"/>		<input type="checkbox"/>
	Added axle	<input type="checkbox"/>	<input type="checkbox"/>	<input type="checkbox"/>	<input type="checkbox"/>				

\* = Upon request axle with drum brakes      ⊗ = With brake pliers assembly at 57° without parking brake      ◇ = With long and cross bars  
 ◆ = With brake pliers assembly at 0°      □ = With parabolic leaf springs

- T = 4x2 tractor  
 TX = 6x2 C tractor (central added axle cannot be lifted)  
 TY = 6x2 P tractor (rear added axle can be lifted)  
 TN = 6x2 vehicles with mechanical rear suspensions and raisable rigid rear added axle  
 TZ = 6x4 tractor (bogie rear axle)  
 P = 4x2 – 6x2P – 6x2C vehicles with air suspension on rear axle and 6x2P vehicles with rigid rear axle that can be lifted with single wheels  
 PT = 6x2P vehicles with air suspension on rear axle and rigid rear added axle that can be lifted with twin wheels  
 PS = 6x2P vehicles with air suspension on rear axle and on steering rear added axle that can be lifted with single wheels  
 FP = 4x2 – 6x4 – 6x2P – 6x2C vehicles with front and rear air suspensions  
 FS = 6x2P vehicles with front and rear air suspensions, steering rear added axle can be lifted with single wheels  
 4x2 = Vehicles with two axles with rear driving axle  
 6x2P = Vehicles with three axles with rear driving axle and rear added third axle that can be lifted  
 6x2C = Vehicles with three axles with rear driving axle and central added third axle that cannot be lifted  
 6x4 = Vehicles with three axles with two rear driving axles (in tandem)  
 CM = Movable Boxes  
 GV = High Volumes  
 HM = Heavy Mission  
 CT = Chassis cab with lowered chassis frame  
 HB = Hub Reduction

**P.I.C. CODE NUMBER****RANGE**

**A**   **A**   **A**   **B**   **B**   **C**   **C**   **D**

**M** ⇒ MP/MH Range (EuroTech)

**L** ⇒ LD Range (EuroStar)

**MODEL**

**A**   **A**   **A**   **B**   **B**   **C**   **C**   **D**

**1** ⇒ = 190E./440E..XT (4x2)

**2** ⇒ = 440E..TX (6x2C)

**3** ⇒ = 260Y (6x2P - single wheel third rear axle)

**4** ⇒ = 260E..-Z/440E..TZ (6x4)

**7** ⇒ = 260EY (6x2P - twin wheel third rear axle)

**MOTORIZATION**

**A**   **A**   **A**   **B**   **B**   **C**   **C**   **D**

**J** ⇒ E39

**K** ⇒ E43

### CONFIGURATION



- A** ⇨ = mechanical suspension
- B** ⇨ = rear air spring suspension (/P) (on fixed axle 6x2P, 3°)
- C** ⇨ = Full Pneumatic suspension (/FP) (on fixed axle 6x2P, 3°)
- E** ⇨ = /Ps: 6x2P with rear air spring suspension, driving axle 3°, single wheels
- F** ⇨ = /FS: 6x2P with Full Pneumatic suspension, driving axle 3° single wheels

### VERSIONS



- I** ⇨ = Standard Cabin
- F** ⇨ = RSU Cabin
- K** ⇨ = HM Cabin = Heavy Mission
- L** ⇨ = Low Cab Cabin  
(CT = Car Transport / GV = Grandi volumi)
- 2** ⇨ = Standard Tractor
- H** ⇨ = HM Tractor = Heavy Mission
- T** ⇨ = Low Tractor

**WHEEL BASE**



A	A	A	B	B	C	C	D
		3650	3800			2800	
						3200	
3805		3800		3805	3805	3500	
4200				4200	4200	3800	
4500				4500	4500		
4800				4800	4800		
5100				5100	5100		
5200							
	5500						
5700	5700			5700	5700		
6300				6050	6050		
6700							
190 4x2	190-CT 4x2	440T 4x2	440TX 6x2C	260Y 6x2P	260Z 6x4	440TZ 6x4	

- ↕ I
- ↕ 2
- ↕ 3
- ↕ 4
- ↕ 5
- ↕ 6
- ↕ 7
- ↕ K
- ↕ L
- ↕ 8
- ↕ 9
- ↕ M

**TRANSMISSION**



16 gears manual transmission (ZF 16S 151, ZF 16S 181, ZF 16S 221)



12 gears automatic transmission (EuroTronic 1800, EuroTronic 12 AS 2301)



**COUNTRY BLOCK-STEERING**



Country Block 1: Europa, LHD

MPC SHORT cab



Country Block 1: Europa, LHD

MPL/LDL LONG cab



Country Block 4: Europa, RHD

MPC SHORT cab



Country Block 4: Europa, RHD

MPL/LDL LONG cab



### Vehicle Identification Data (EUROTECH)

Engine type and number, frame type and number and manufacturer's plates are your vehicle's identification data.

#### Manufacturer's plates

Data for vehicle identification according to EEC directives (below the front radiator grill).

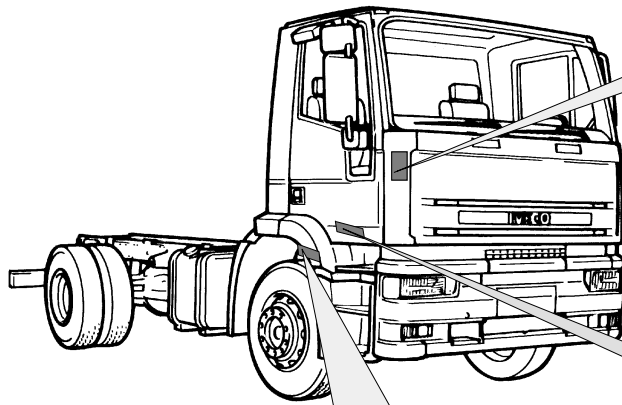
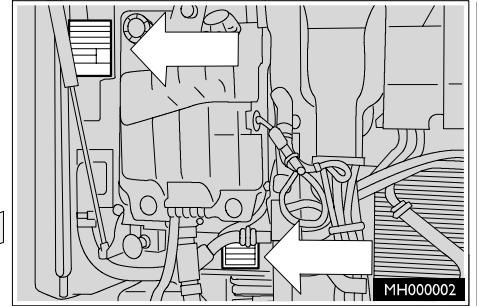

#### Engine

Plate on left-hand rear side of engine block

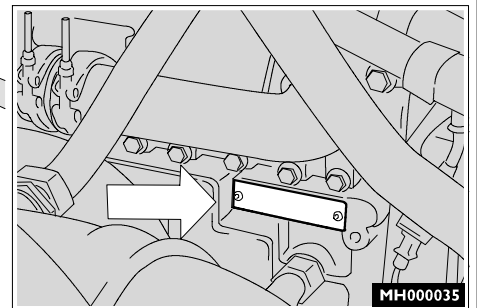

#### Chassis

Stamped (on right-hand side member of the chassis front end).

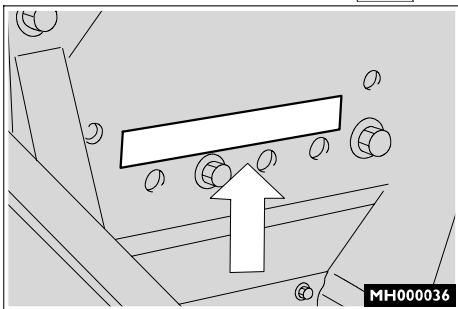

#### Vehicle identification plate

Explanation

- a) Certification number stamping (if required).
- b) Vehicle Identification Number (V.I.N.).
- c) Total weight of the vehicle.
- d) Total weight of vehicle + trailer (if provided).
- e) Maximum permitted weight on 1<sup>st</sup> axle.
- f) Maximum permitted weight on 2<sup>nd</sup> (if fitted).
- g) Maximum permitted weight on 3<sup>rd</sup> axle.
- h) Maximum permitted weight on 4<sup>th</sup> axle (if provided).
- i) Type identification mark.
- l) Wheelbase in mm.
- m) Engine type.
- n) Engine power.
- o) No. of axles.
- p) Production plant.

- a)
- b)
- c)
- d)
- e)
- f)
- g)
- h)
- i)
- l)
- m)
- p)

<b>IVECO SPA</b>		
_____		
_____		
_____		Kg
_____		Kg
1-		Kg
2-		Kg
3-		Kg
4-		Kg
Type		N° of axles
Wheelbase		Corrected absorption value
Engine type	Engine power KW	o)
n)		
Made in		<b>IVECO</b>

#### Product Identification Code plate

This plate indicates the P.I.C., which is necessary to look up information in the **spare parts' catalogue** (on electronic data medium and/or microfiche). The P.I.C. is indicated on the vehicle warranty card as well.

**Note.** To look up information in catalogues, use the first 8 P.I.C. characters only.

<b>Unit No</b>	_____
<b>Part No</b>	_____
<b>Serial No</b>	_____
<b>P.I.C. No</b>	_____
<b>Made in Germany-Iveco Magirus AG</b>	
<b>IVECO</b>	
9843 8247	

Admissible smoke value



### Vehicle Identification Data (EUROSTAR)

Engine type and number, frame type and number and manufacturer's plates are your vehicle's identification data.

#### Manufacturer's plates

Data for vehicle identification according to EEC directives (below the front radiator grill).

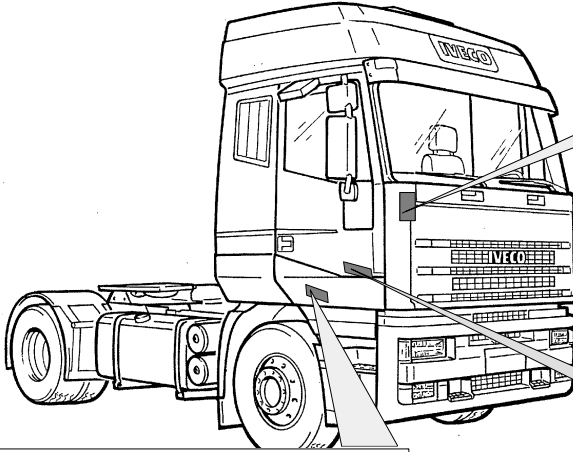
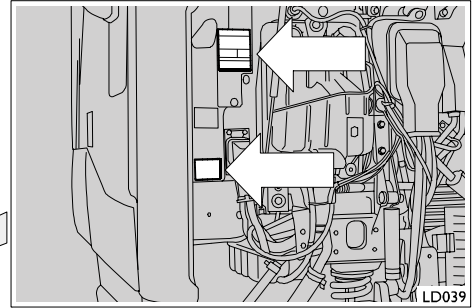

#### Engine

Plate on left-hand rear side of engine block

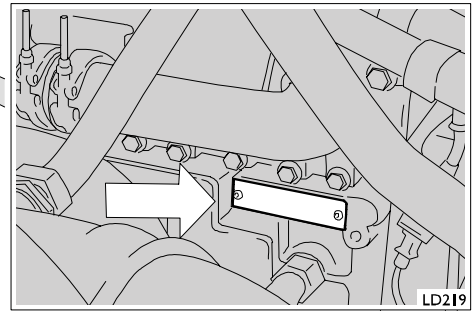

#### Chassis

Stamped (on right-hand side member of the chassis front end).

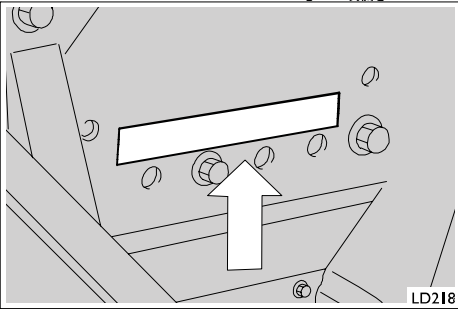

#### Vehicle identification plate

Explanation

- a) Certification number stamping (if required).
- b) Vehicle Identification Number (V.I.N.).
- c) Total weight of the vehicle.
- d) Total weight of vehicle + trailer (if provided).
- e) Maximum permitted weight on 1<sup>st</sup> axle.
- f) Maximum permitted weight on 2<sup>nd</sup> (if fitted).
- g) Maximum permitted weight on 3<sup>rd</sup> axle.
- h) Maximum permitted weight on 4<sup>th</sup> axle (if provided).
- i) Type identification mark.
- l) Wheelbase in mm.
- m) Engine type.
- n) Engine power.
- o) No. of axles.
- p) Production plant.

#### Product Identification Code plate

This plate indicates the P.I.C., which is necessary to look up information in the **spare parts' catalogue** (on electronic data medium and/or microfiche). The P.I.C. is indicated on the vehicle warranty card as well.











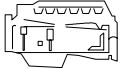

**Note.** To look up information in catalogues, use the first 8 P.I.C. characters only.

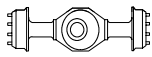
<b>IVECO MAGIRUS AG</b>			
a)	_____		
b)	_____		
c)	_____ Kg		
d)	_____ Kg		
e)	1-	_____ Kg	
f)	2-	_____ Kg	
g)	3-	_____ Kg	
h)	4-	_____ Kg	
i)	Type	N° of axles	
l)	Wheelbase	Corrected absorption value <input style="width: 50px; height: 30px;" type="text"/>	
m)	Engine type		
		<b>n)</b>	
	Made in		
	<b>IVECO</b>		
p)	_____		

<b>Unit No</b>
_____
<b>Part No</b>
_____
<b>Serial No</b>
_____
<b>P.I.C. No</b>
_____
<b>Made in Germany-Iveco Magirus AG</b>
<b>IVECO</b>
9843 8247

Admissible smoke value

## FILLING UP

LUBRICANTS RECOMMENDED BY IVECO		PARTS FOR REPLENISHING		Quantity		
				Litres	kg	
	<b>Urania FE 5W30<sup>1</sup></b> Urania LD5 Urania Turbo LD		Engine F3A			
			Total capacity 1 <sup>st</sup> filling	30	29.8	
			Capacity:			
			- engine sump at minimum level	17	15.3	
			- engine sump at maximum level	25	22.5	
			- quantity in circulation that does not return to sump	7	6.3	
			- quantity contained in cartridge filter (to add when changing the cartridge filter)	2.5	2.3	
	<b>Tutela Truck FE-Gear<sup>1</sup></b> Tutela ZC 90		Gearbox			
			ZF 16 S 151 *	11	10	
			ZF 16 S 151 + Intarder*	18.5	16.65	
			ZF 16 S 181 *	13	12	
			ZF 16 S 181 + Intarder*	21.5	19.35	
			ZF 16 S 221 *	13	12	
			ZF 16 S 221 + Intarder*	21.5	19.35	
			Eurotronic 1800*	11	10	
			Eurotronic 1800*+Intarder	21	19	
			Eurotronic 12 AS 2301*	11	10	
Eurotronic 12 AS 2301 + Intarder*	21	19				
* Quantity 1 <sup>st</sup> filling						
	<b>Tutela Truck FE-Axle<sup>1</sup></b> Tutela W140/M-DA Tutela W90/M-DA <sup>3</sup>		Front hubs (single)			
			FRONT AXLE 5876/4-/5 (F8021)	0.35	0.32	
			ADDED AXLE::			
			Steering central 5876/2 (F8021)	0.35	0.32	
			Steering rear 57080/DI (N8072)	0.35	0.32	
	<b>Tutela Truck FE-Axle<sup>2</sup></b> Tutela W140/M - DA Tutela W90/M-DA <sup>3</sup>		Rear axle U 177 - MS13 - 175	17	15.5	
			Rear axle 45 1391	16	14.5	
			Rear axle in tandem RT 160:			
			- middle	18.5	16.6	
			- rear	16.5	14.8	
	Tutela GI/A		Power steering	2.7*	2.4	
				13.5**	12	
* Excluding vehicles with steering rear axle						
** For vehicles with steering rear axle only						
	Tutela DOT SPECIAL		Clutch circuit (excluding vehicles with Euro Tronic gearbox)	0.5	0.45	
	Paraflu <sup>1</sup>		Cooling system			
			Engine	Total capacity*	~38	~34.2
			Engine + gearbox	Total capacity*	~58	~52.2
			with Intarder			
* = Protective anti-freeze (concentration 50% freezing point -35°C)						
	Tutela LHM		Cab tilting system	0.7	-	
<p>(1) IVECO suggests using these oils to achieve in terms of "fuel economy". The new vehicle is already fitted by IVECO with these types of lubricants. They are also suitable for cold climates (minimum temperature up to -30°C)</p> <p>(2) Only for axles with disc brakes. Note (1) stands good for them</p> <p>(3) Specific for cold climates</p> <p>These quantities are not conclusive. The exact check must be performed by inspecting levels.</p>						

International designations of lubricants and fluids	Fiat Lubricants	
<b>Engine oil</b> Meeting specifications: <b>To completely synthetic base ACEA E4</b> Mineral based ACEA E5 Mineral based ACEA E3	<b>SAE 50W 30</b> SAE 15W 40 SAE 15W 40	<b>URANIA FE 5W30</b> Urania LD5 Urania Turno LD
<b>Oil for differentials and wheel hubs</b> Complies with: <b>To completely synthetic base API GL5, MT-1</b> Mineral based API GL5 Mineral based API GL5	<b>SAE 75W 90</b> SAE 85W 140 SAE 80W 90	<b>Tutela Truck FE-Axle</b> Tutela W140/M-DA Tutela W90/M-DA
<b>Oil for mechanical gearbox, containing non EP wear resistant additives.</b> Complies with: <b>To completely synthetic base API GL4</b> Mineral based API GL3	<b>SAE 75W 85</b> SAE 80W 90	<b>Tutela Truck FE-Gear</b> Tutela ZC90
<b>Oil for hydrostatic transmission</b> A.T.F. DEXRON II D		Tutela GI/A
<b>Grease for general use</b> with base of lithium soap, consistency N.L.G.I. no. 2		Tutela MR 2
<b>Grease for bearings and wheel hubs</b> with base of lithium soap, consistency N.L.G.I. no. 3		Tutela MR 3
<b>Fluid for hydraulic brakes and clutch control</b> Complies with standards: N.H.T.S.A. 116, ISO 4925, Std. SAEJ 1703, IVECO STANDARD 18-1820		Tutela TRUCK DOT SPECIAL
<b>Mineral oil for hydraulic circuits</b> Complies with: <b>FIAT 9.55597-IVECO STANDARD 18-1823 and CITROEN</b>		Tutela LHM
<b>Windshield washer liquid, mixture of alcohols, water and surface tensioners</b> CUNA NC 956-11		Tutela PROFESSIONAL SC 35
<b>Grease for centralised lubrication systems</b> with base of lithium soap (synthetic base), N.L.G.I. no. 2. Operating temperatures: -30 °C to +140 °C		Tutela COMAR 2
<b>Radiator concentrated protective fluid</b> Complies with IVECO-STANDARD 18-1830		Parafllu <sup>11</sup>

## SECTION 2

**Engine**

	Page
VIEWS OF THE ENGINE	4
TECHNICAL DESIGNATION	7
GENERAL CHARACTERISTICS	10
ASSEMBLY CLEARANCE DATA	13
FAULT DIAGNOSIS	19
DESCRIPTION	19
DIAGNOSTIC INSTRUMENTS	19
CONTROL UNIT TEST	20
ENGINE TEST	20
AUXILIARY FUNCTIONS	20
DETECTION OF MECHANICAL FAILURE	21
TIGHTENING TORQUE	24
TOOLS	29
ENGINE REMOVAL - REFITTING	39
<input type="checkbox"/> Removal	39
<input type="checkbox"/> Refitting	40
DISMANTLING THE ENGINE ON THE BENCH	43
REPAIR OPERATIONS	50
CYLINDER BLOCK	50
<input type="checkbox"/> Checks and measurements	50
CYLINDER LINERS	51
<input type="checkbox"/> Replacing cylinder liners	52
<input type="checkbox"/> Removal	52
<input type="checkbox"/> Fitting and checking protrusion	52
CRANKSHAFT	53
<input type="checkbox"/> Measuring main journals and crank pins	54
DETERMINATION OF PRELIMINARY DATA FOR SELECTION	60