

VIEWS OF THE ENGINE

Figure 1

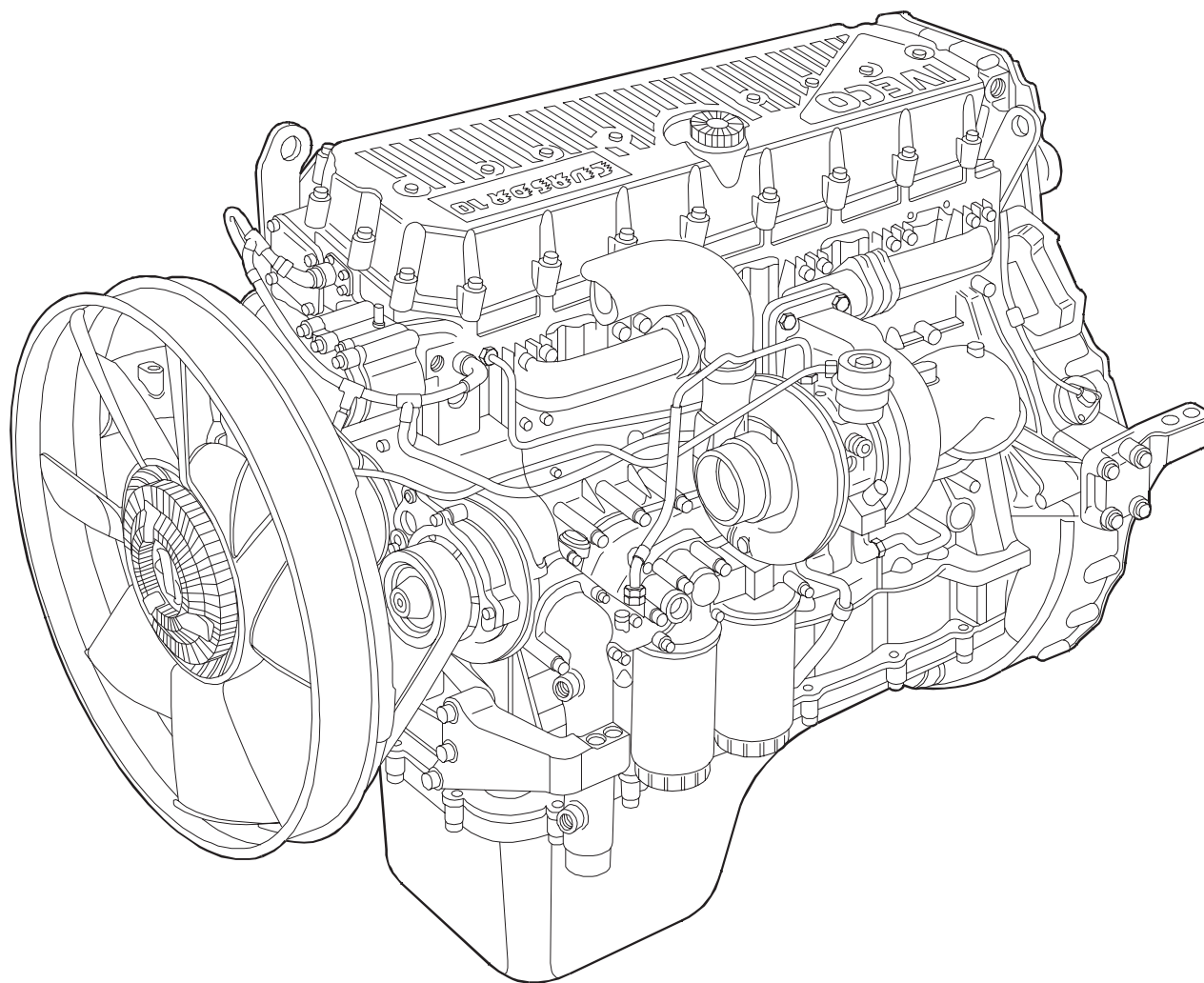

73835

F3A ENGINE

Figure 2

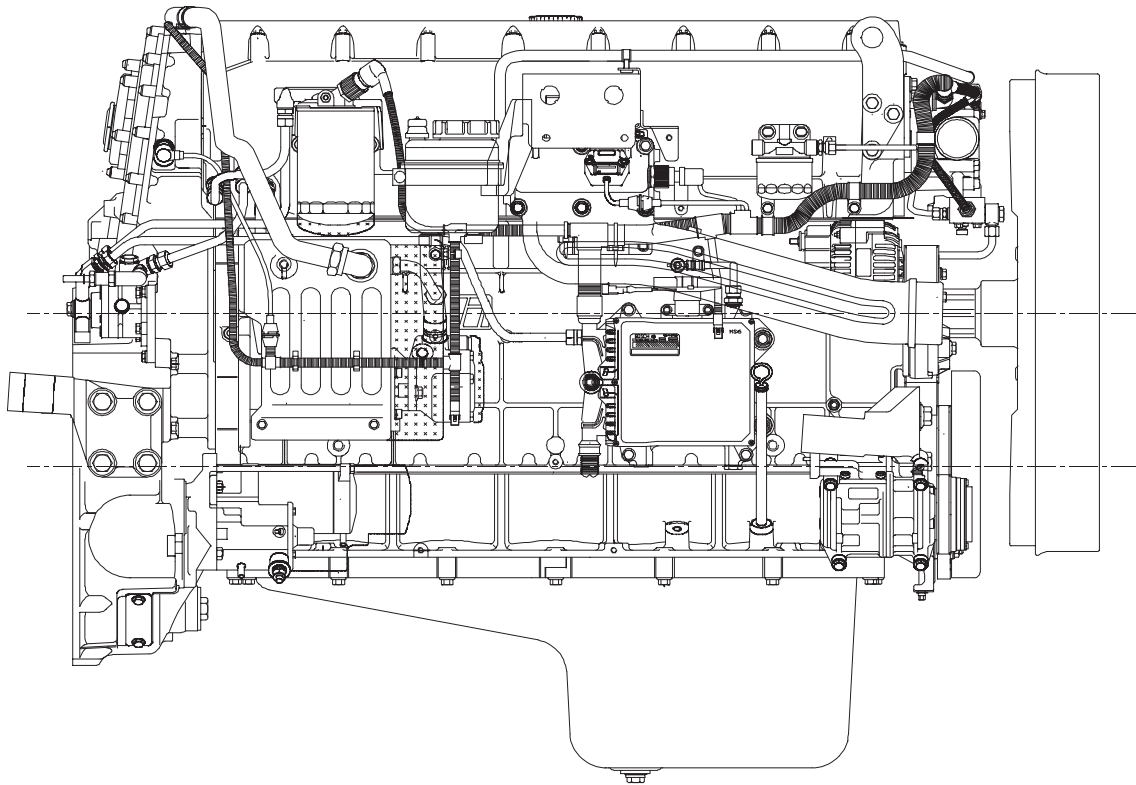

73526

RIGHT-HAND SIDE VIEW OF THE ENGINE

Figure 3

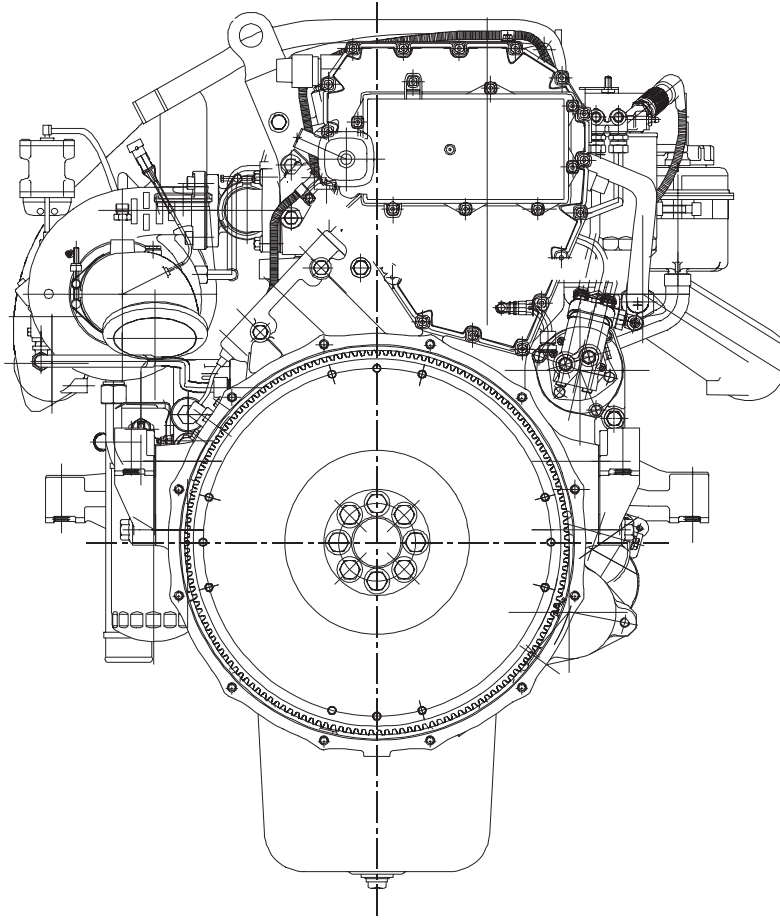

73527

REAR VIEW OF THE ENGINE

Figure 4

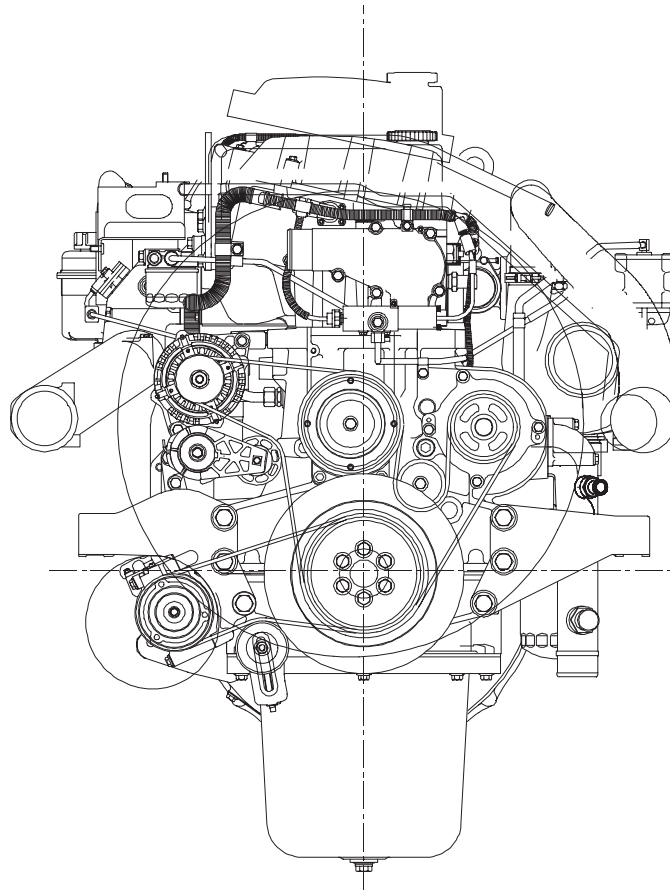

73528

RIGHT-HAND SIDE VIEW OF THE ENGINE

Figure 5

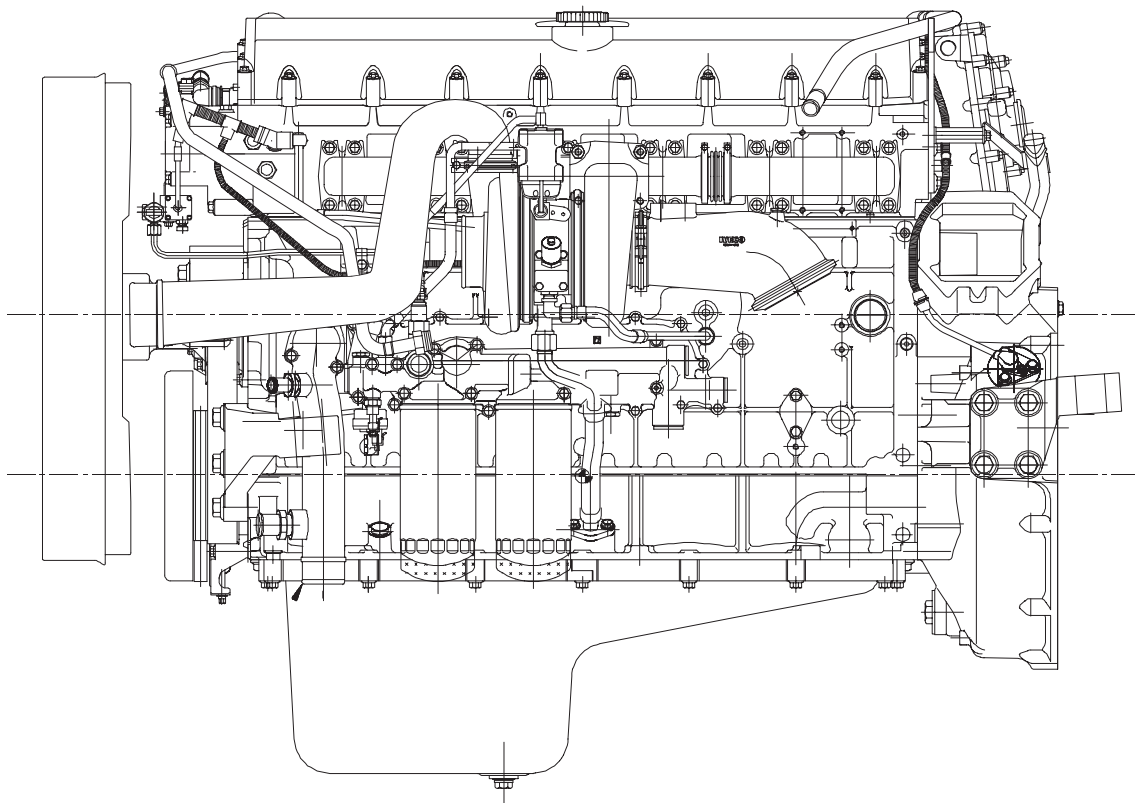

73529

LEFT-HAND SIDE VIEW OF THE ENGINE

Figure 6

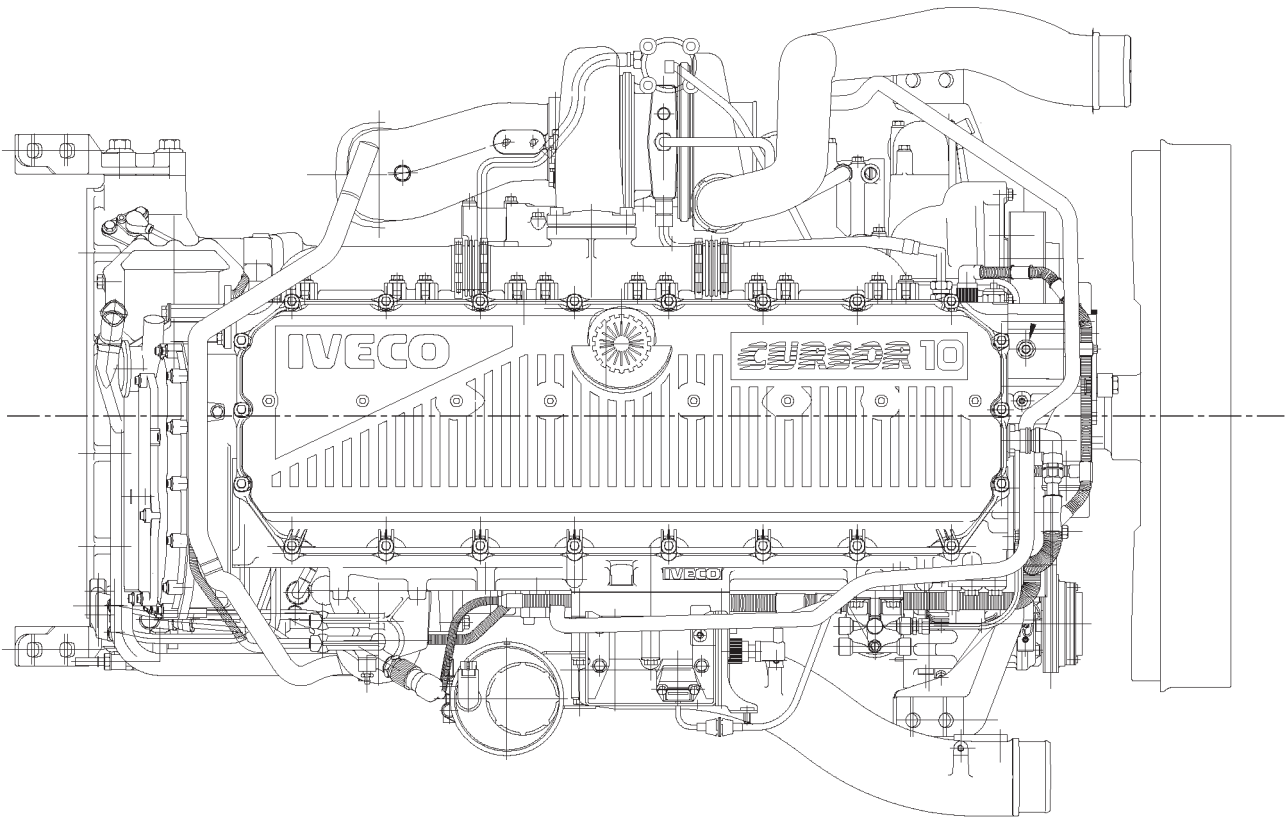

73834

VIEW OF THE ENGINE FROM ABOVE

TECHNICAL DESIGNATION

ENGINE

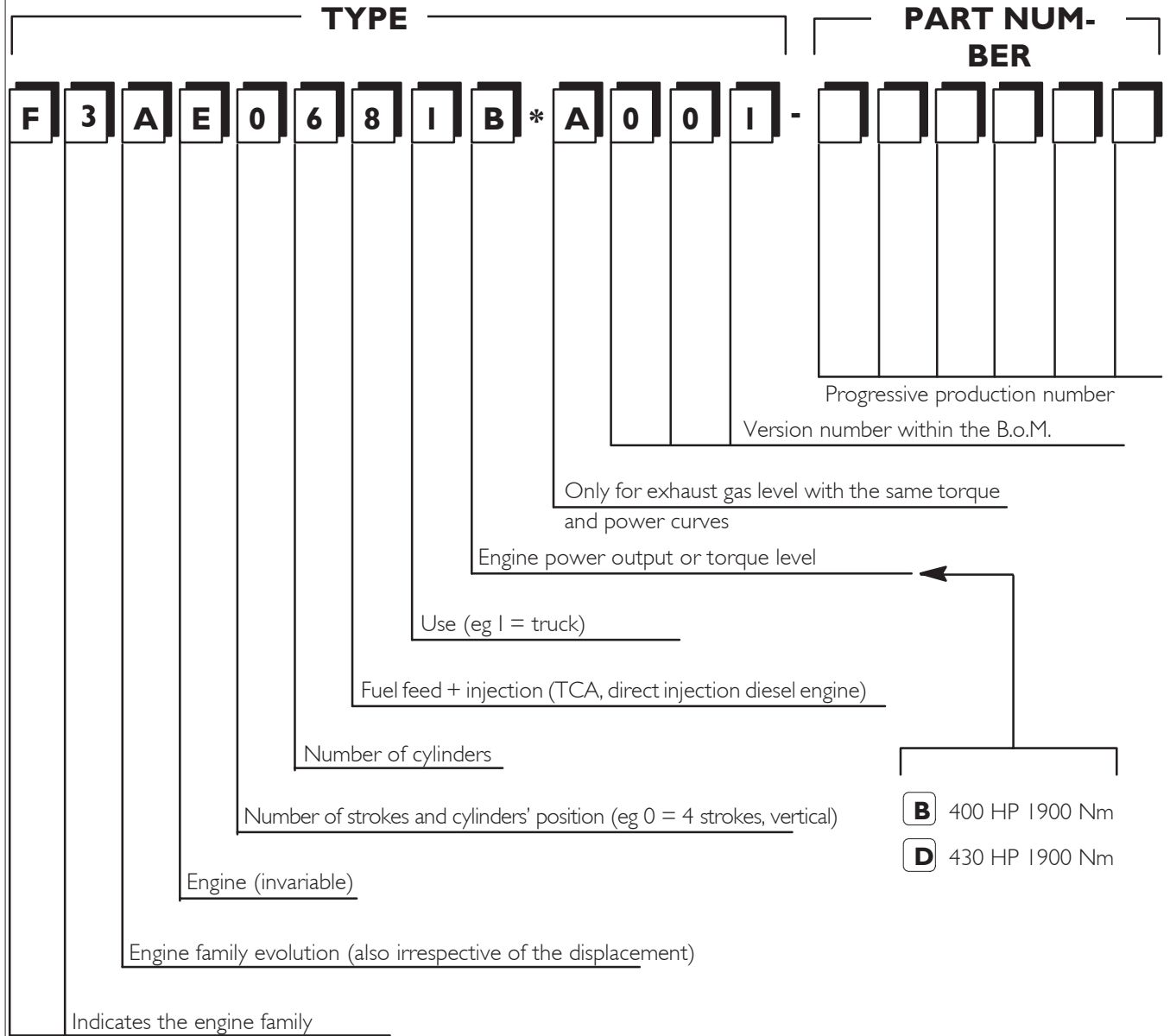

CHARACTERISTIC CURVES

Figure 7

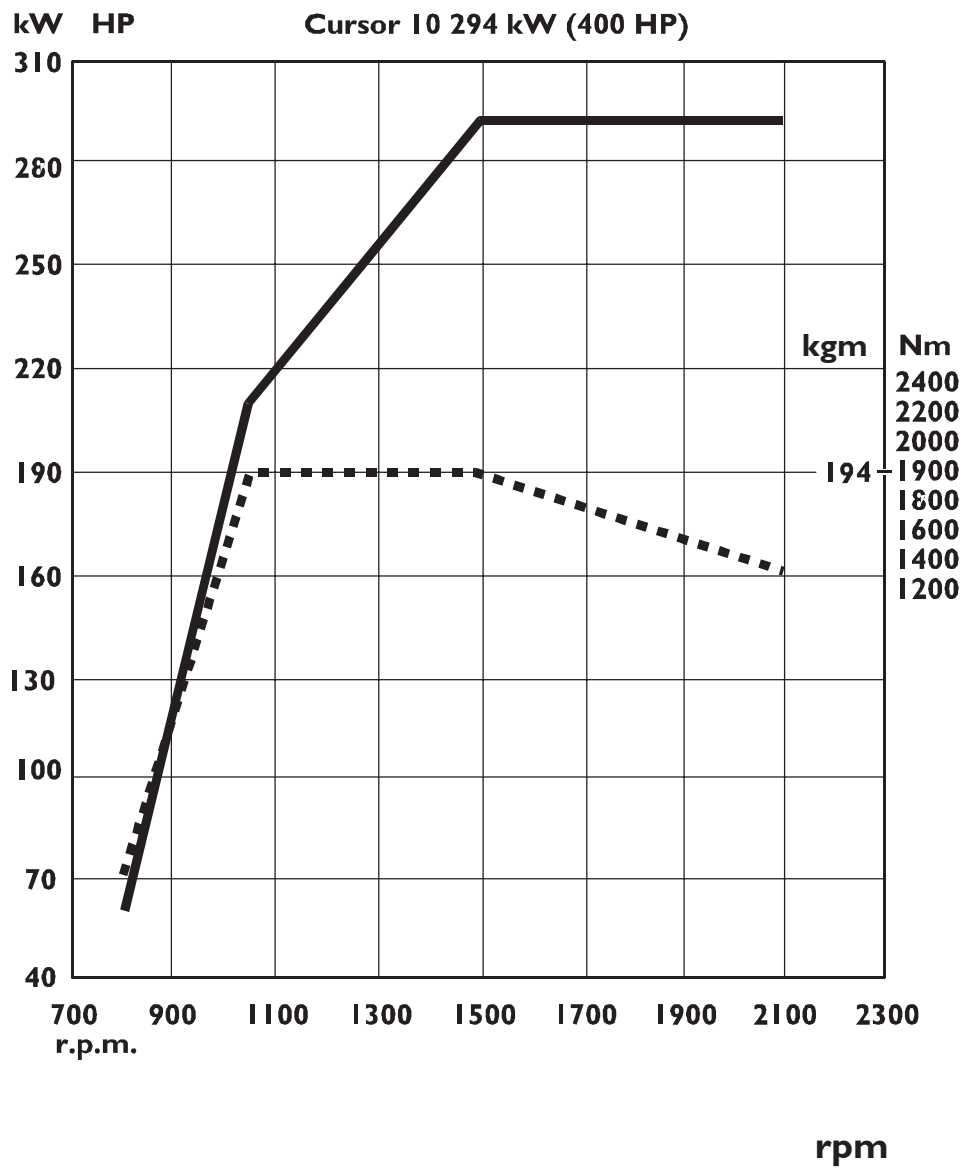

73531

CHARACTERISTIC CURVES OF ENGINE F3AE 0681B

Max OUTPUT 294 kW

400 HP

at 2100 rpm

Max TORQUE 1900 Nm

194 kgm

at 1050 ÷ 1480 rpm

17

Figure 8

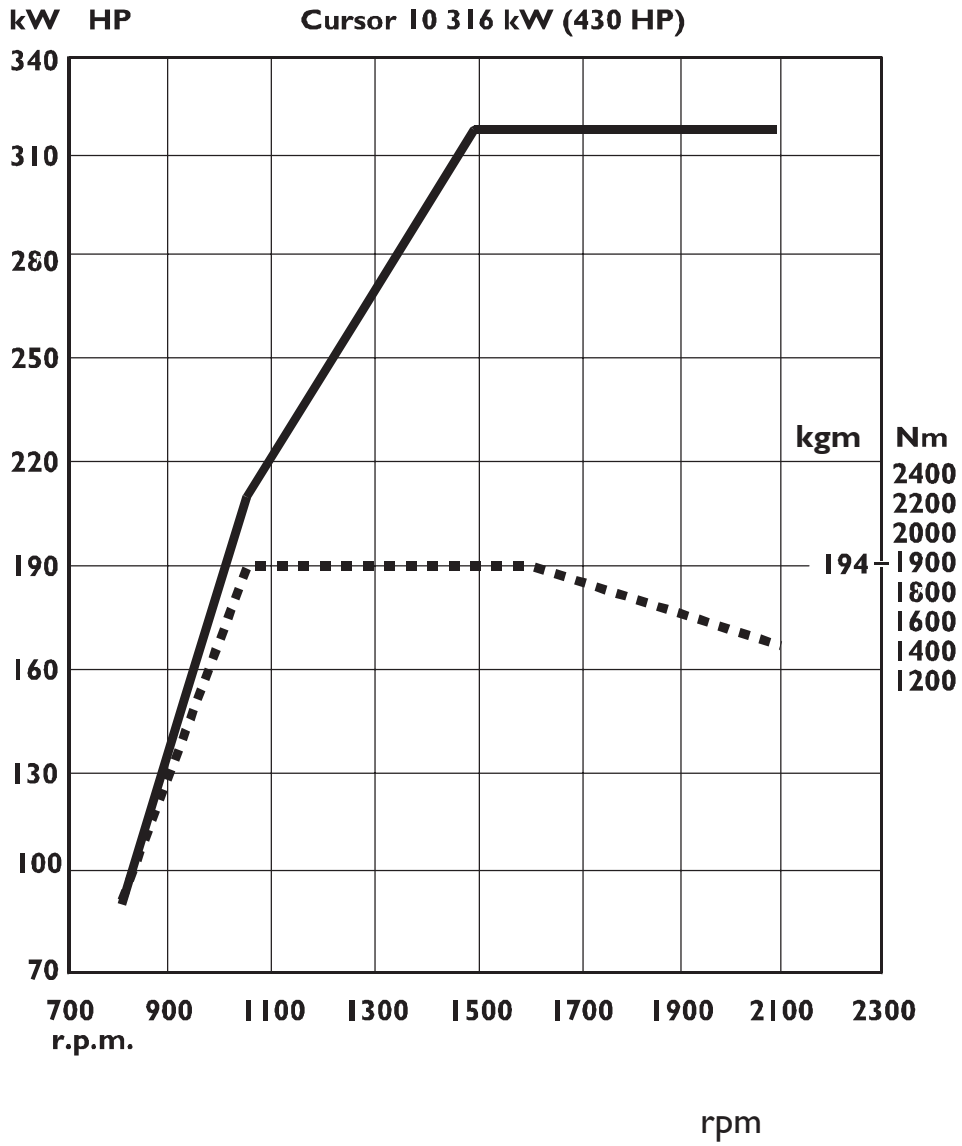

73532

CHARACTERISTIC CURVES OF ENGINE F3A068 1D

Max OUTPUT 316 kW

430 HP











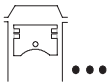

at 2100 rpm

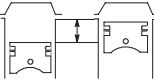
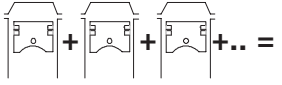
Max TORQUE 1900 Nm

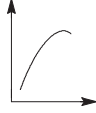
194 kgm

at 1050 ÷ 1590 rpm

GENERAL CHARACTERISTICS

	Type		F3AE0681B	F3AE0681D
	Cycle		4-stroke Diesel engine	
	Fuel feed		Turbocharged with aftercooler	
	Injection		Direct	
	No. of cylinders		6 in line	
	Bore	mm	125	
	Stroke	mm	140	
	Total displacement	cm ³	10300	
	Compression ratio		17 ± 0.8	
	Max output	KW (HP)	294 (400)	316 (430)
		rpm	2100	2100
	Max. torque	Nm (kgm)	1900 (194)	1900 (194)
		rpm	1050 ÷ 1480	1050 ÷ 1590
	Engine idling speed, no load	rpm	550 ±25	
	Maximum engine speed, no load	rpm	2550 ±20	