

C13 ENT M77

TECHNICAL AND REPAIR MANUAL

JUNE 2007 EDITION

TECHNOLOGICAL EXCELLENCE

**IVECO
MOTORS**



FOREWORD

We strongly recommend that you carefully read the indications contained in this document: compliance with these indications protects the engine from irregular operation, assures reliability, safeguards sea-going and protects maintenance personnel from accident hazards.

The indications contained in this document pertain to the C13 ENT M77.10 marine engines and complement the IVECO MOTORS-FPT "Marine Diesel Engines Installation Handbook". You should refer to this for anything that is not explained herein.

Technical engineers and fitters must comply with work safety regulations. They must implement and adopt the methods foreseen for personal safety while carrying out maintenance or checks.

There is a reminder of the safety rules in Section 9 of the present publication.

There is a reminder of the regulations for engine handling at the end of Section 6 of the present publication.

To start the engine, you must adhere to the procedure stated at the end of Section 5 of the present publication.

To get best engine performance you must conform with its intended mission profile. The engine must not be used for purposes other than those stated by the manufacturer.

IVECO MOTORS-FPT is available for a prior examination of any requirements regarding special installations, should this be necessary.

In particular

- ❑ Use of unsuitable fuels and oils may compromise the engine's regular operation, reducing its performance, reliability and working life.
- ❑ Exclusive use of IVECO MOTORS-FPT Original Parts is a necessary condition to maintain the engine in its original integrity.
- ❑ Any tampering, modifications, or use of non-original parts may jeopardize the safety of service personnel and boat users.

To obtain spare parts, you must indicate:

- Commercial code, serial number and the indications shown on the engine tag;
- The number of the spare part. This can be found in the spare part catalog.

The information provided below refers to engine characteristics current at the date of publication.

IVECO MOTORS-FPT reserves the right to make modifications at any time and without advance notice, to meet technical or commercial requirements or to comply with local legal and regulatory requirements.

**We refuse all liability
for any errors and omissions.**

The reader is reminded that the IVECO MOTORS-FPT Technical Assistance Network is always at the Customer's side with its competence and professionalism.

IVECO MOTORS-FPT Publication edited by:
IVECO PowerTrain
Advertising & Promotion
Pregnana Milanese (MI)
www.ivecomotors.com

Printed **P3D32C003 E** - June 2007 Edition

SECTION CONTENTS

Section	Page
1. OVERVIEW	5
2. TECHNICAL DATA	35
3. ELECTRICAL EQUIPMENT	41
4. DIAGNOSTICS	69
5. MAINTENANCE	89
6. SERVICING OPERATIONS ON INSTALLED ENGINE	95
7. TOOLS	113
8. OVERHAUL	125
9. SAFETY SYSTEM FOR HOMOLOGATED INSTALLATIONS	197
10. SAFETY REGULATIONS	221

Indications for consultation

Sections 1-2-3 are intended for sales personnel, to provide them with an exact knowledge of the product's characteristics and enable them to accurately meet the Customer's requirements.

The remaining sections are intended for the personnel that has the task of performing both ordinary and extraordinary maintenance; by referring carefully to the chapter devoted to diagnosis, they too will be able to provide an effective service of technical assistance.

PAGE LEFT INTENTIONALLY BLANK

SECTION 1

OVERVIEW

	Page
IDENTIFICATION DATA	7
Identification Tag	7
COMMERCIAL CODE	8
PRODUCT MODEL NUMBER	9
ENGINE PARTS AND COMPONENTS	10
ENGINE ARCHITECTURE	12
COMBUSTION AIR INTAKE AND EXHAUST SYSTEM	14
Air/sea water heat exchanger	15
Combustion air pre-heating	15
COOLING FRESH WATER CLOSED LOOP	16
Tube bundle water/water heat exchanger	17
Bypass junction for thermostatic valve	17
SEA WATER OPEN COOLING LOOP	18
Sea water pump	19
ENGINE OIL - LUBRICATION LOOP	20
Gear pump	21
Oil vapor filter	21
Pre-lubrication system (on request)	21
Commutable filters (on request)	21
FUEL LINES	22
Hydraulic schematic diagram	23
INJECTION SYSTEM - EDC	24
EUI electrically controlled pumping injector	25
Electrical and electronic components	27
System functions	30
Reference signals	32

PAGE LEFT INTENTIONALLY BLANK

IDENTIFICATION DATA

Figure 1

Identification Tag

IVECO S. p. A.			
Viale dell'Industria, 15/17 - 20010 Pregnana Mil.se MI - ITALY			
ENGINE TYPE	<input type="text"/>		
ENGINE FAMILY	<input type="text"/>	ENGINE DWG	<input type="text"/>
POWER (KW) AND SPEED (RPM)	<input type="text"/>	POWER SET CODE	<input type="text"/>
ENGINE S/N	<input type="text"/>	YEAR OF BUILD	<input type="text"/>
HOMOLOGATION	<input type="text"/>	N°	<input type="text"/>
COMMERC. TYPE / VERSION	<input type="text"/>	<input type="text"/>	<input type="text"/>

04_002_N

Figure 2

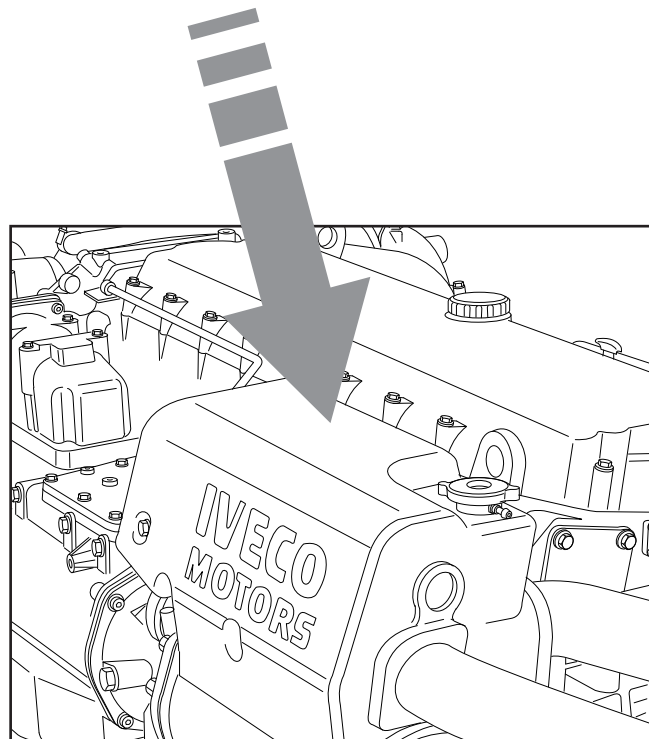

05_001_C

The engine identification data are stenciled on a tag positioned over the engine coolant tank.

COMMERCIAL CODE

The purpose of the commercial code is to make it easier to understand the characteristics of the product, categorizing the engines according to their family, origins and intended application. The commercial code, therefore, cannot be used for technical purposes and to identify the engine's components, this is the purpose of the "ENGINE S/N".

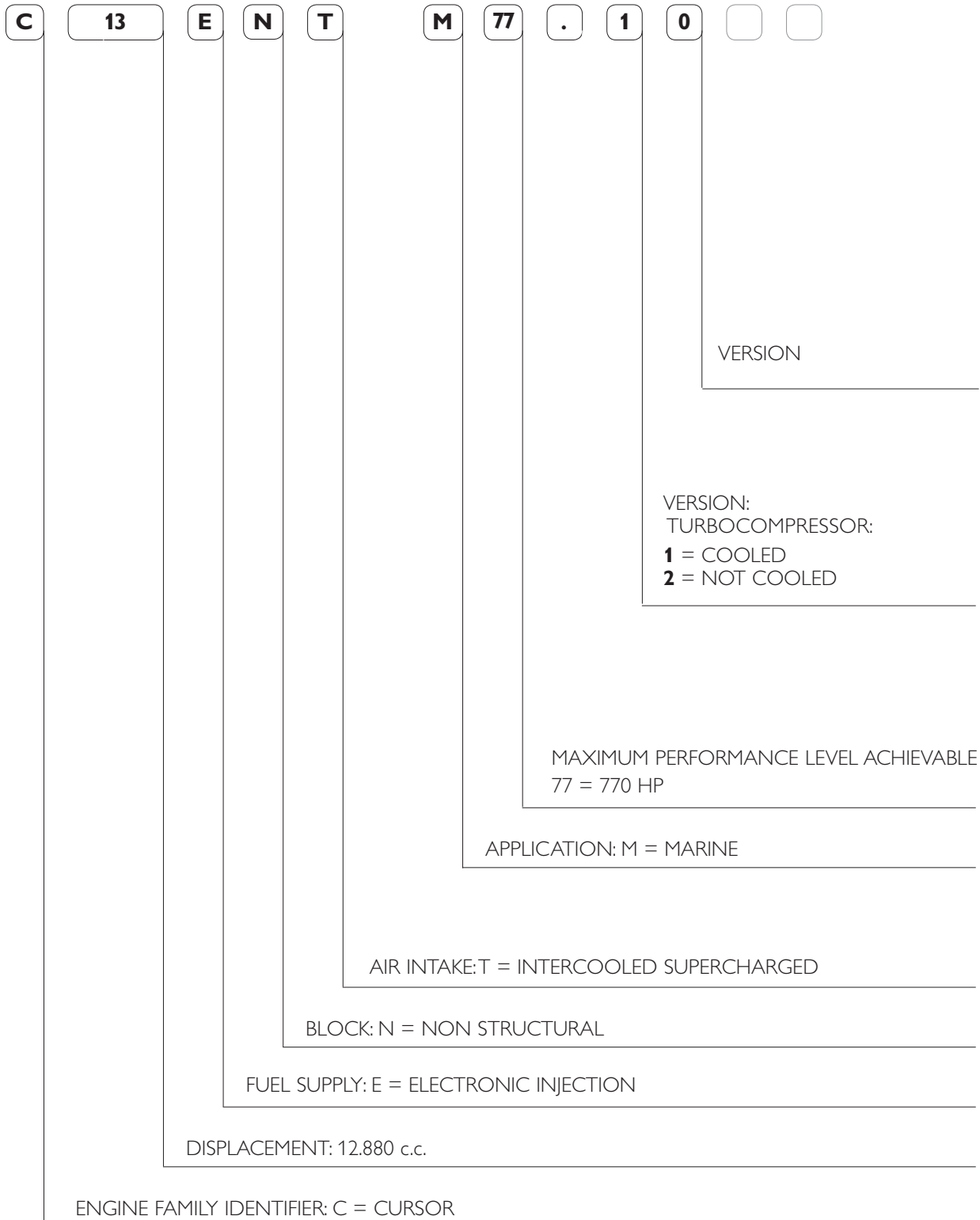

PRODUCT MODEL NUMBER

The model number is assigned by the manufacturer; it is used to identify the main characteristics of the engine, and to characterize its application and power output level. It is stamped on the side of the crank-case.

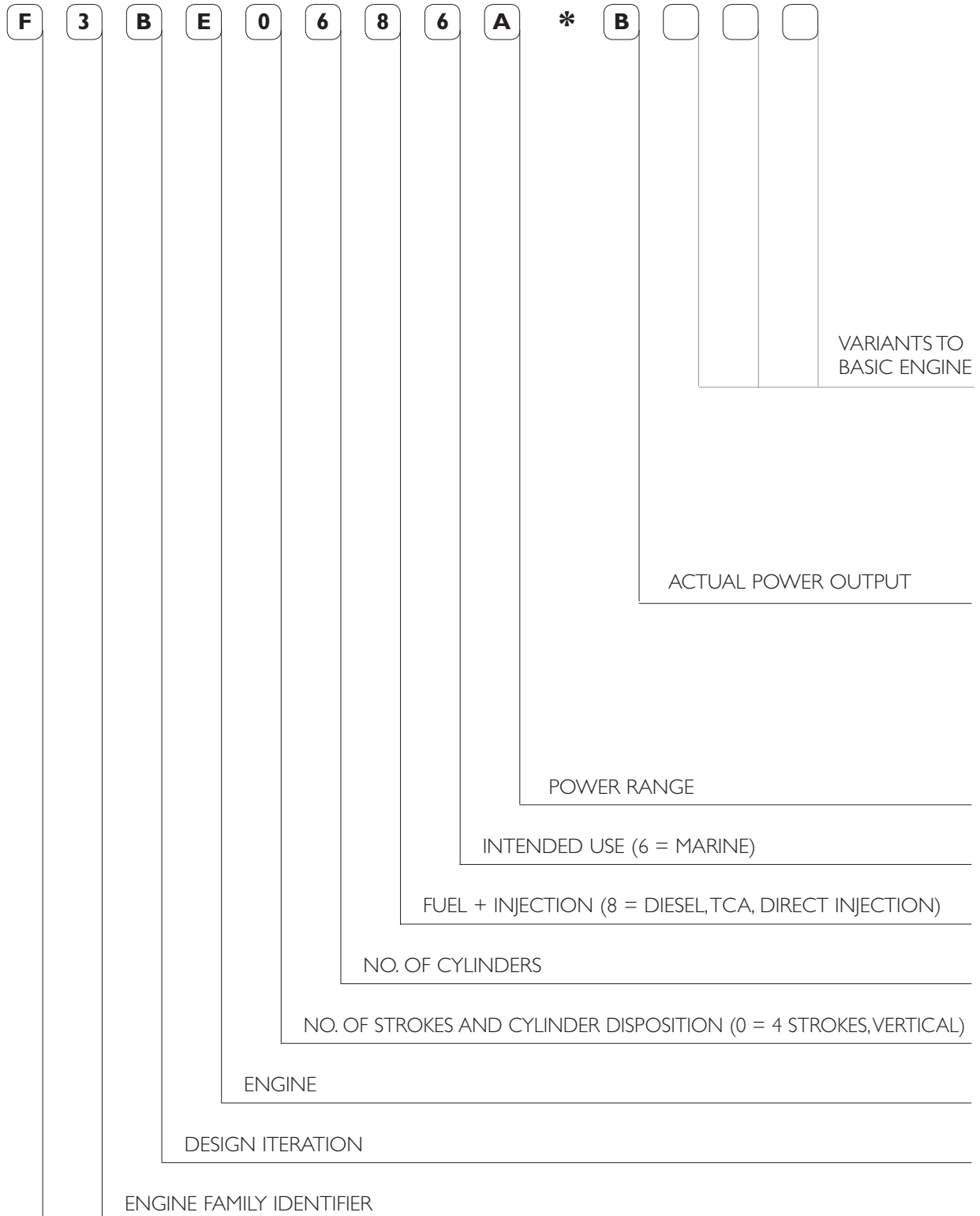

ENGINE PARTS AND COMPONENTS

Figure 3

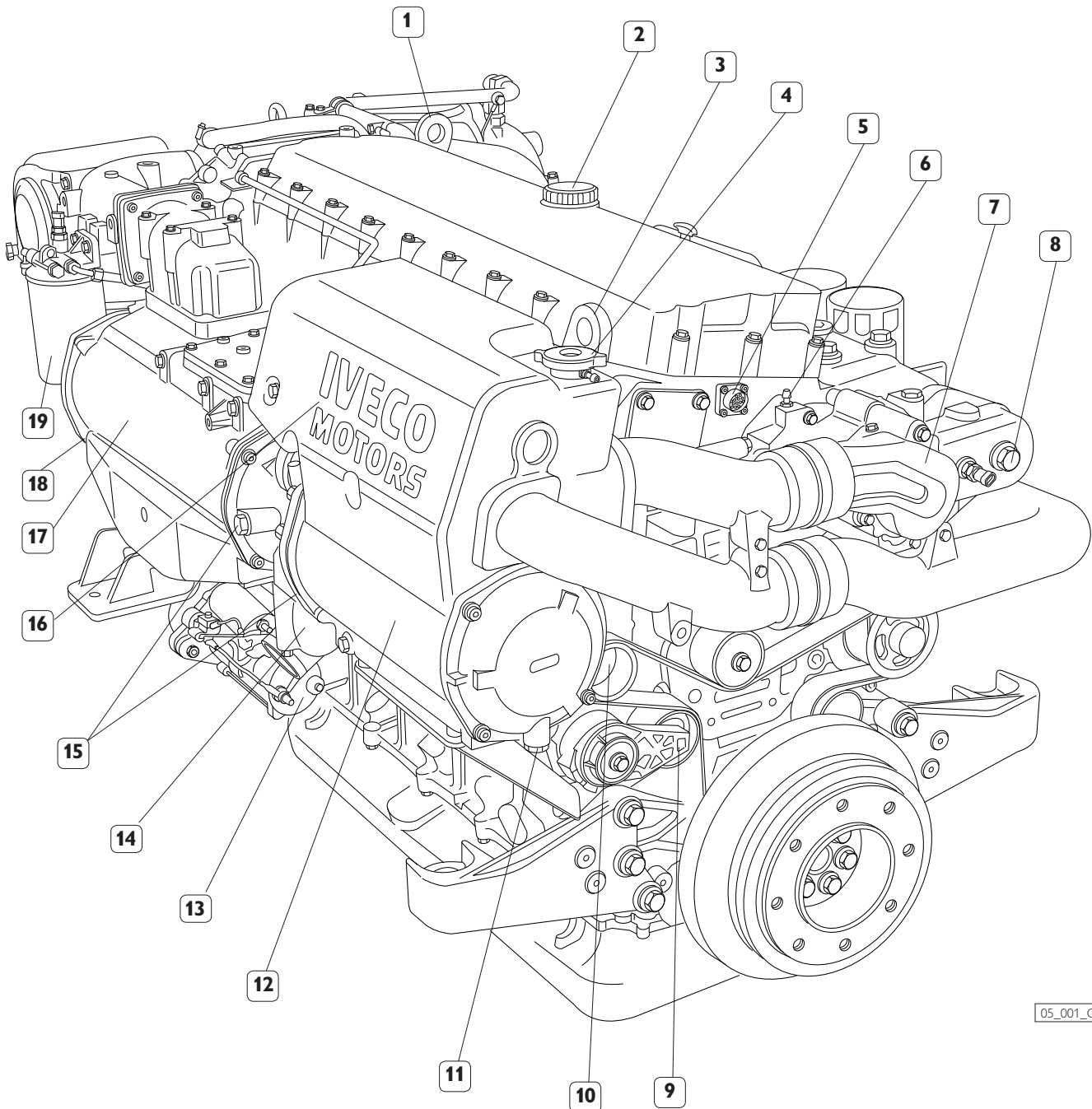

05_001_C

1. Lifting padeye - 2. Lubricating oil refill cap - 3. Lifting padeye - 4. Coolant refill cap - 5. Injector solenoid valve connector - 6. Fuel loop purge fitting - 7. Location of thermostatic valve - 8. Cap for engine coolant outlet to sanitary water heating system - 9. Auxiliary belt automatic tensioner - 10. Alternator location - 11. Sacrificial anode and cap for engine coolant discharge - 12. Coolant-sea water tube bundle heat exchanger - 13. Electrical starter motor - 14. Sea water pump - 15. Sacrificial anode - 16. Engine coolant tank - 17. Air-sea water heat exchanger - 18. Sacrificial anode - 19. Fuel filter.

ENGINE PARTS AND COMPONENTS

Figure 4

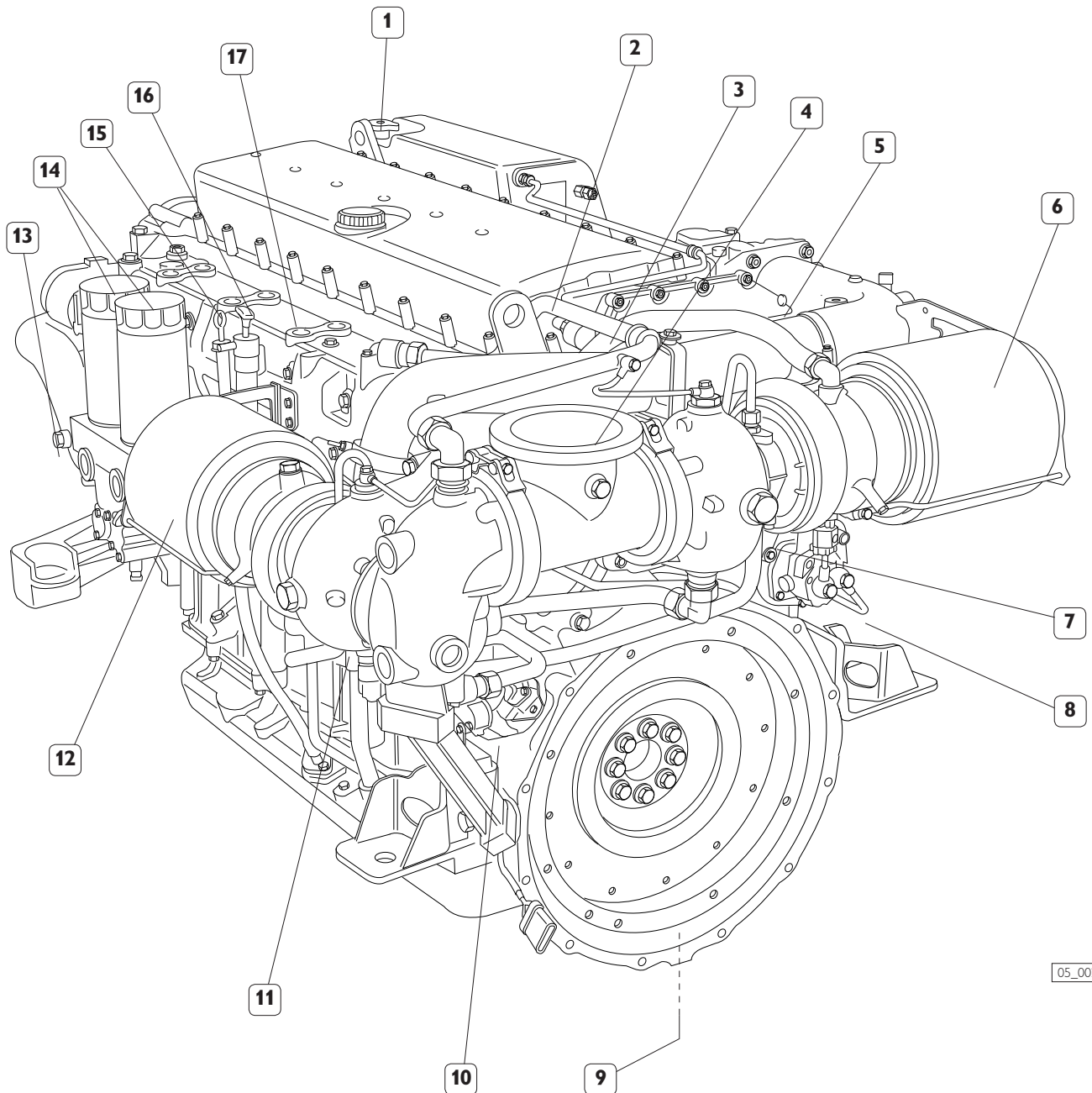

05_002_C

1. Lifting padeye - 2. Lifting padeye - 3. Oil filter clogging indicator - 4. Exhaust gas outlet flange - 5. Timing mechanism and oil vapor filter cover - 6. Intake air filter (A) - 7. Cooled turbo-charger (A) - 8. Fuel transfer pump - 9. Timing phase inspection port - 10. Throttle position sensor potentiometer - 11. Cooled turbo-charger (B) - 12. Intake air filter (B) - 13. Cap for engine coolant discharge and recirculation from sanitary water heating system - 14. Lubricating oil filters - 15. Lubricating oil dipstick - 16. Manual lubricating oil extraction pump - 17. Cooled exhaust manifold.

ENGINE ARCHITECTURE

Figure 5

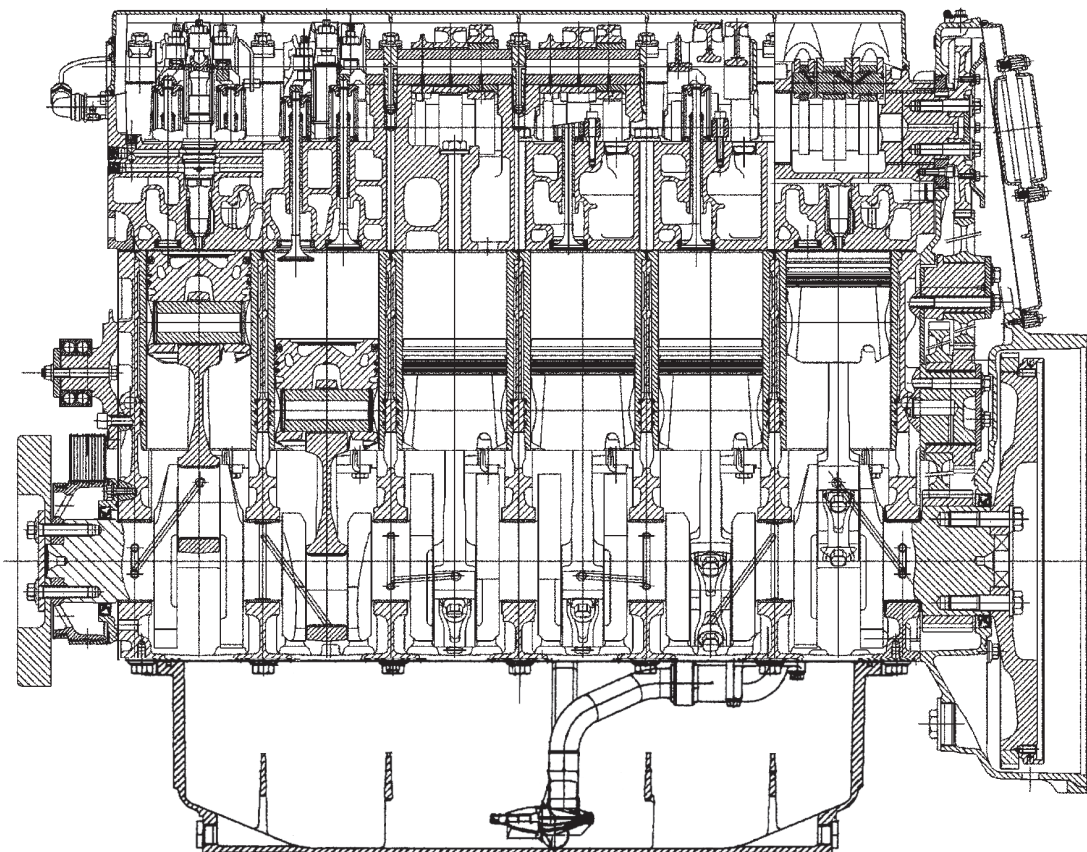

05_076_C

With the CURSOR series engines, IVECO MOTORS-FPT has reached unequalled standards in power delivery for industrial, marine, and automotive uses; CURSOR engines are the result of a continuous research process aimed at product improvement, and they inherit no elements of previous propulsion units. They adopt the most rational and effective solutions to achieve, with smaller displacement engines, power outputs that are typical of larger, heavier engines.

The architecture of these engines is characterized by six cylinders in line, four valves per cylinder and roller rocker arms with overhead cam shaft and "bonded" block.

Electronic control extended to all functions ensures reliable and durable operation, offering important benefits in terms of performance and usage.

IVECO MOTORS-FPT's contribution to environmental protection is amply demonstrated by the CURSOR engines' environmental performance: fumes and noise are well below current regulatory requirements and compliance with future limits was the target of the whole design effort.

The 24 valve cylinder head with its camshaft with seven supports, incorporates the intake manifold and the conduits for the cooling and lubrication fluids, as well as for fuel supply.

The overhead camshaft with roller rocker arms directly activates both the valves and the EUI (Electrical Unit Injector).

Figure 6

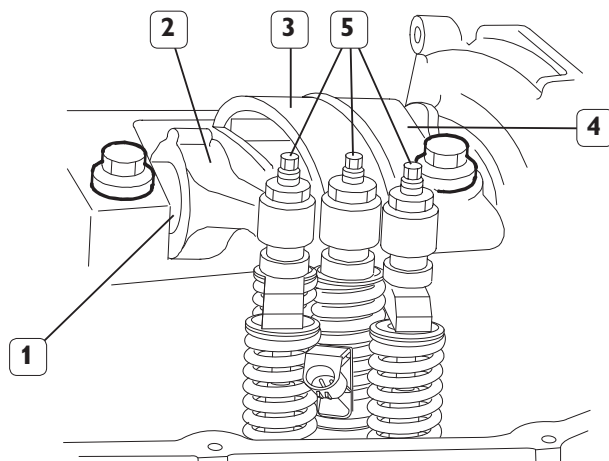

05_084_C

1. Rocker arm shaft -
2. Intake valve rocker arm -
3. Pump injector rocker arm -
4. Exhaust valve rocker arm -
5. Calibration screw.

Figure 7

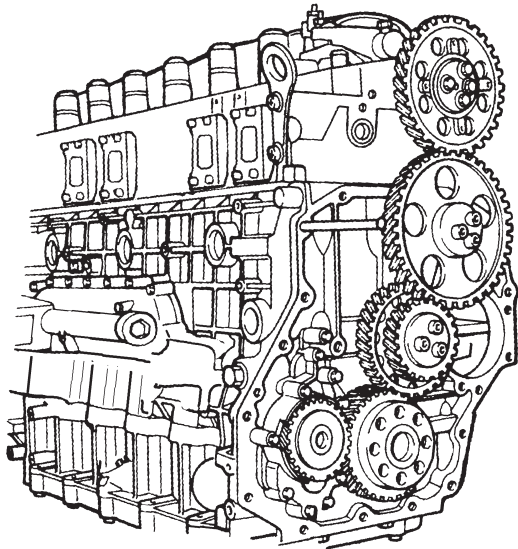

80824

Timing control is to the rear to reduce torsional effects and it is built with helical tooth gears to contain noise.

Figure 8

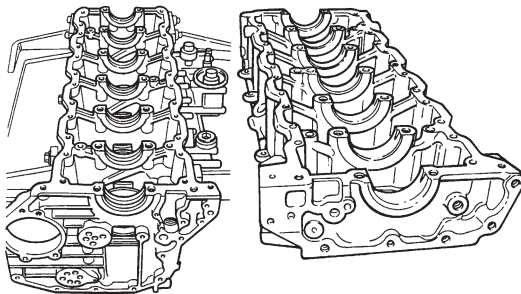

80825

Block and sub-block constitute a rigid assembly to reduce vibration and noise and secure the drive shaft with seven shaft supports. Aluminum pistons provide effective heat dissipation.

Pump injectors are mounted at the center of the combustion chamber and provide the highest possible thermodynamic efficiency thanks to an injection that is able to reach pressures that exceed 1800 bar. Electrically driven by the electronic control, they deliver fuel at a time that minimizes fuel consumption and contains gas emissions, while maximizing torque and power output.

The EDC, Electronic-Diesel-Control system, constantly monitors environmental and engine operating conditions, providing an optimized injection control to maximize performance at all times. Even when operating in critical conditions, control is optimized. This permits navigation and operation to continue in complete safety.

The electronic unit's control over the entire engine's efficiency provides information about the engine's global performance and other, specific, information for each cylinder, thereby making servicing operations easy; associated with the testing of the working condition of the injection system's electrical and electronic components, it stores information about the most significant events that occur during the engine's operation and allows maintenance personnel to anticipate the onset of faults and resolve them.

COMBUSTION AIR INTAKE AND EXHAUST SYSTEM

Figure 9

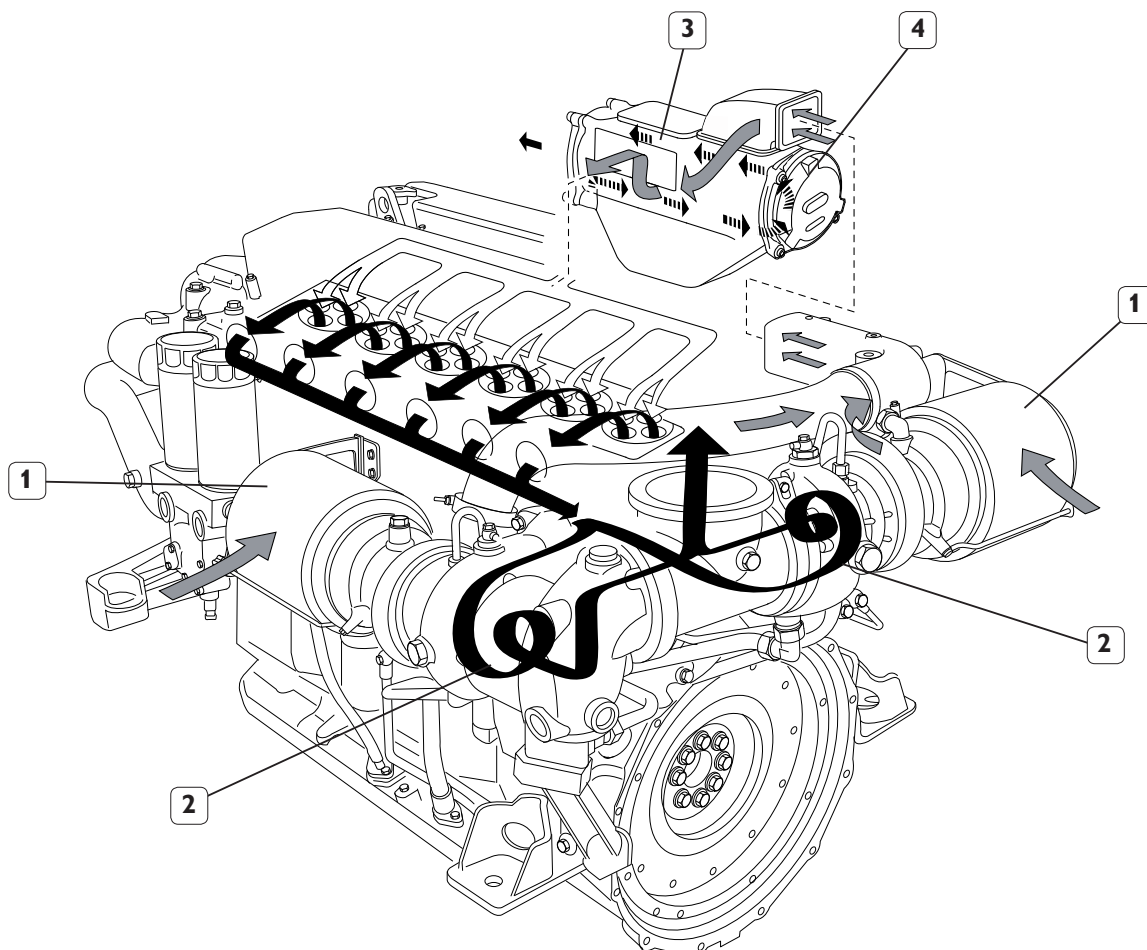

05_022_C

Intake
 Exhaust
 Sea water

1. Air filters - 2. Turbocompressors - 3. Air/sea water heat exchanger - 4. Sea water.

Description and Operation

Air, drawn in and compressed by the turbocompressors, flows through the heat exchanger together with sea water. The latter, by reducing temperature, allows an increase in the engine's volumetric efficiency.

The air density at the inlet of the intake manifold is measured by two sensors, for pressure and temperature, allowing the ECU of the EDC system to calculate fuel dosage relative to the actual quantity of air available for combustion.

Lubricating oil vapors (blow-by) not condensed in the separator, are sent to the engine intake by a gauged hole downstream of the air filters.

Exhaust gas expelled by the engine flows through the cooled exhaust manifold to reach the turbocompressor rotors. Exhaust manifold and turbocompressor body are cooled by the fresh water loop. Exhaust gases flow into the exhaust terminal and, when provided, they are mixed with the sea water it carries for overboard discharge.

Air/sea water heat exchanger

Figure 10

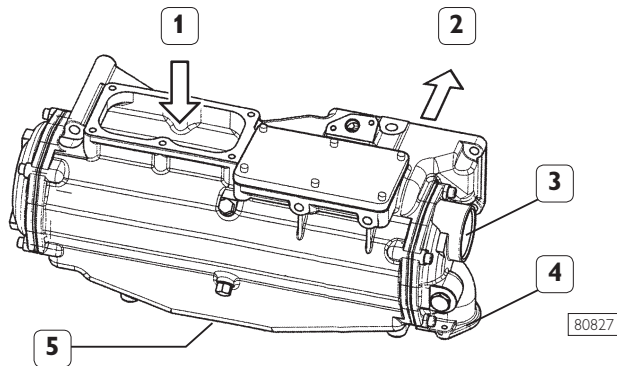

1. Air inlet from the turbocompressor - 2. Outlet for air cooled by the sea water and destined to the intake manifold - 3. Sea water outlet - 4. Sea water inlet - 5. Condensed water outlet.

Combustion air pre-heating (not available at the moment)

Figure 11

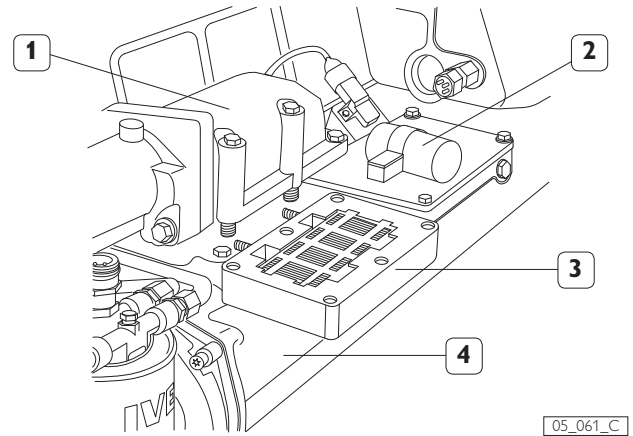

1. Pre-heating junction - 2. Power relay - 3. Electrical heating element - 4. Air/water heat exchanger.

Engine start is guaranteed down to $-15\text{ }^{\circ}\text{C}$ without the aid of any pre-heating system. If the engine needs to be used at lower temperatures, there are provisions (on request) for the installation of an electrical heating element driven by the injection system ECU.

When the ECU, through its sensors, recognizes the presence of a temperature below the prescribed threshold, it will energize the power relay that controls the electrical supply to the grid heater.

The heating element will be located at the inlet of the air/water heat exchanger (after-cooler) after replacing the overlying junction.

COOLING FRESH WATER CLOSED LOOP

Figure 12

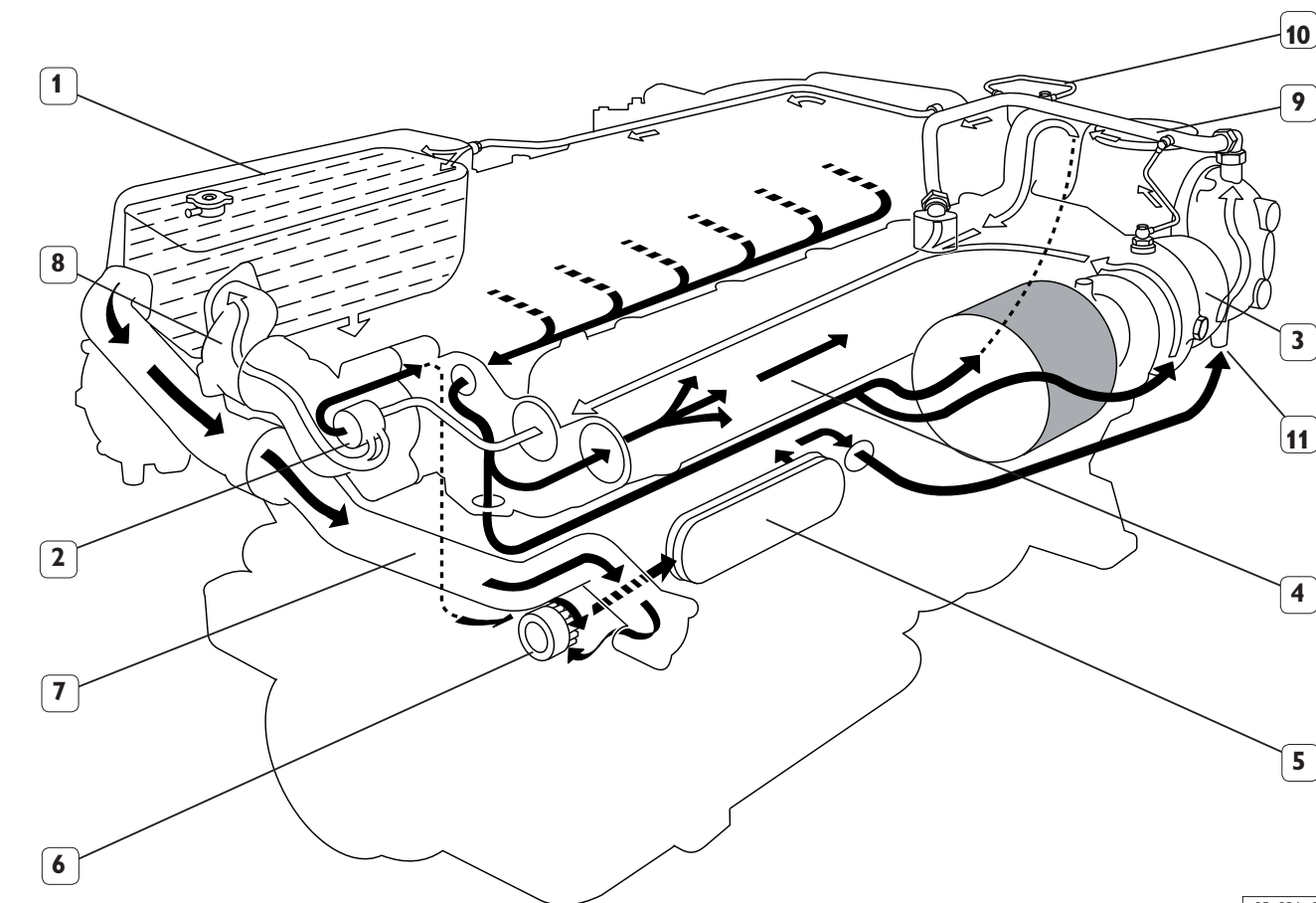

05_021_C

□ High temperature liquid

■ Low temperature liquid

1. Coolant (fresh water) heat exchanger - 2. Thermostatic valve - 3. Side turbocompressor - 4. Exhaust manifold - 5. Engine oil/coolant heat exchanger - 6. Coolant pump - 7. Coolant intake duct from heat exchanger - 8. Coolant delivery duct to heat exchanger - 9. Coolant recirculation from turbocompressors and exhaust manifold junction - 10. Coolant recirculation from rear turbocompressor - 11. Side turbocompressor coolant inlet. MARZO 2006

Description and operation

The centrifuge pump, rotated by the drive shaft with a poly-V belt, draws in the coolant coming from the fresh water/sea water heat exchanger or from the exhaust manifold cooling loop and sends it into the block, where it comes in contact with the lubricating oil heat exchanger. It then touches the heat exchange areas of the cylinders and subsequently those of the engine head, from which it exits flowing through the junction fitting that contains the temperature sensors for the instrument panel and the injection system. This junction has the purpose of bypassing the coolant from the engine head to the exhaust manifold and from the exhaust manifold to the thermostat - which routes it according to the temperature either to the water/water heat exchanger or to the recirculation pump.

From the bypass fitting the liquid is then injected into the heat exchange chamber of the exhaust manifold - through which it flows going to touch the body of the waste gate, of a portion the exhaust and of the turbo compressor. When it returns into the bypass junction it comes in contact with the wax actuator of the thermostatic valve. This will throttle flows according to temperature.

Part of the liquid will enter the tank and flow through the tube bundle heat exchanger, releasing heat to sea water, while the rest will go directly to the pump, to be recirculated.

Tube bundle water/water heat exchanger

Figure 13

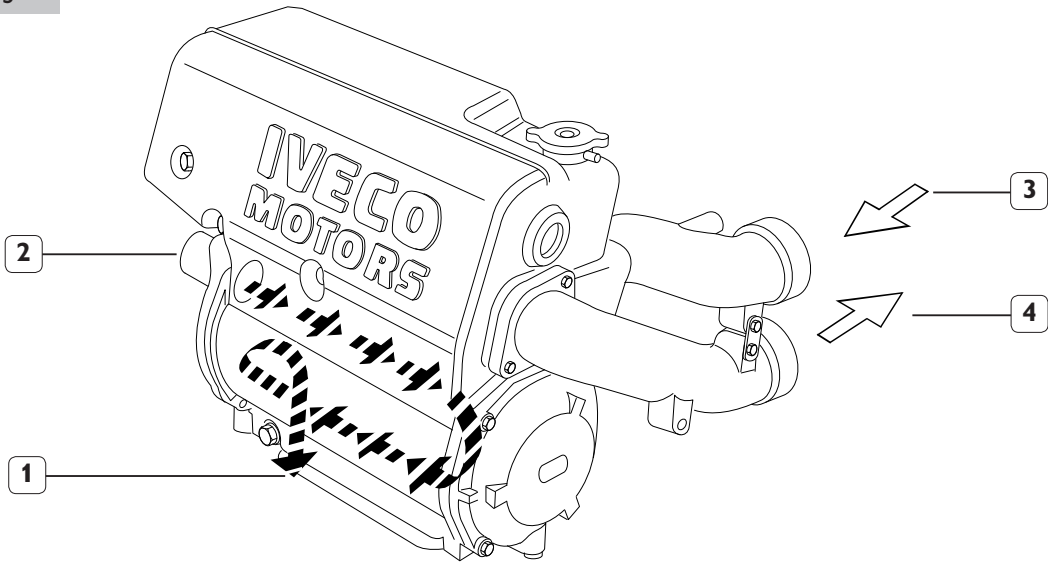

05_077_C

High temperature liquid

Sea water

- 1. Sea water outlet to overboard discharge - 2. Sea water inlet from after cooler - 3. Coolant inlet from thermostatic valve - 4. Coolant outlet to pump.

Bypass junction for thermostatic valve

Figure 14

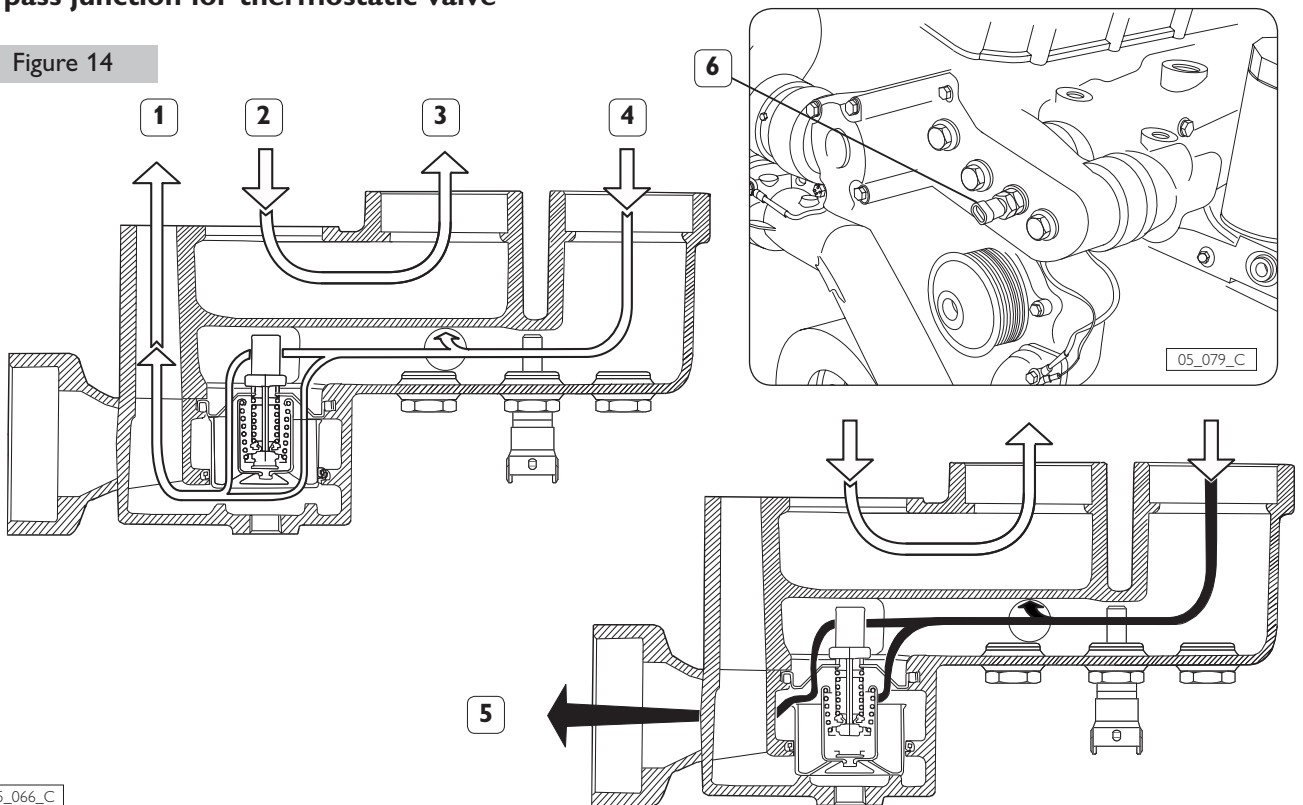

05_079_C

05_066_C

- 1. Bypass flow to engine - 2. Outflow from engine - 3. Outflow from exhaust manifold - 4. Inflow to exhaust manifold - 5. Flow to sea water heat exchanger - 6. temperature sensor.

SEA WATER OPEN COOLING LOOP

Figure 15

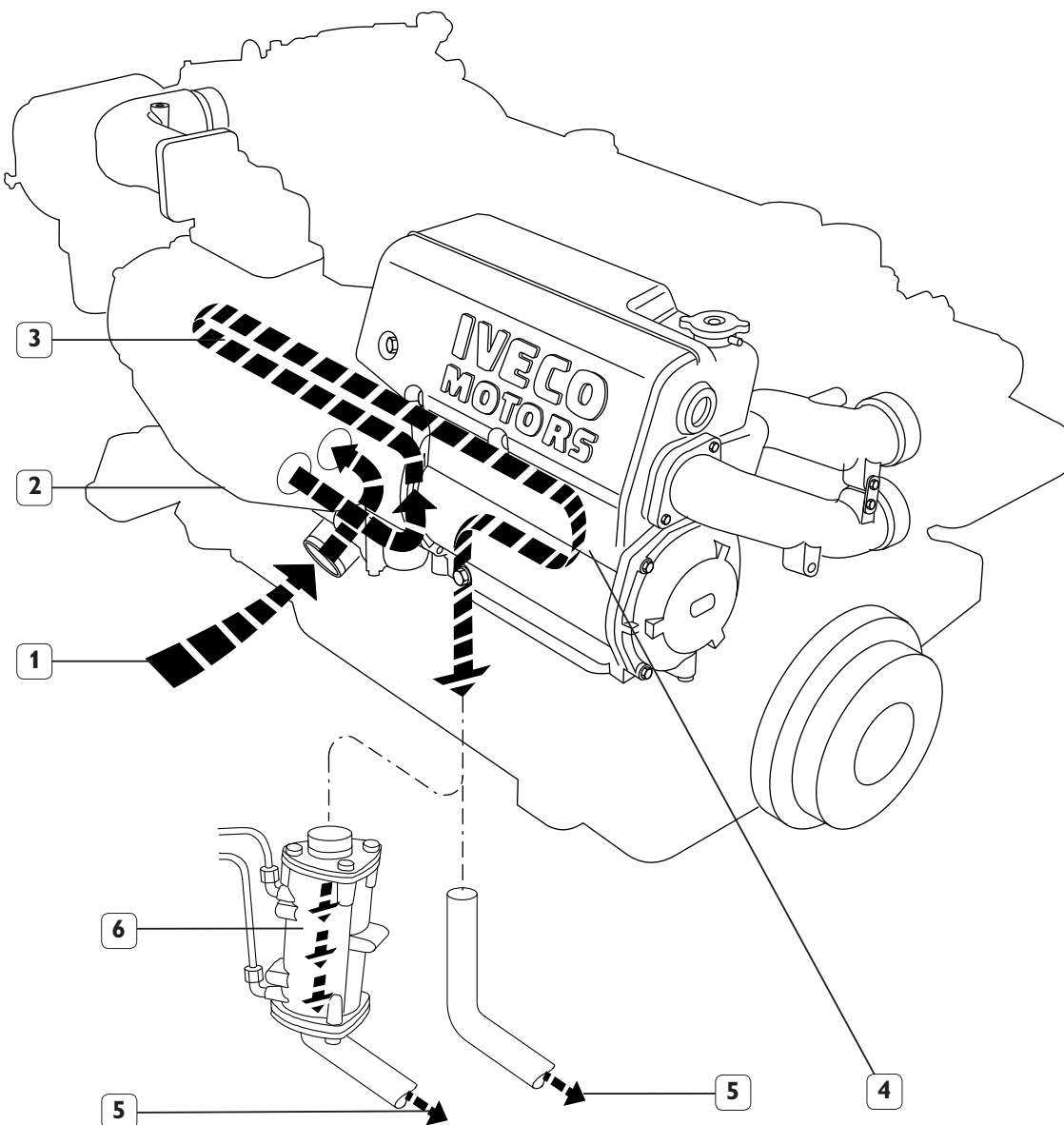

05_080_C

■■■■ Sea water

1. Sea water suction - 2. Sea water pump - 3. Supercharger air heat exchanger - 4. Coolant (fresh water) heat exchanger - 5. Sea water outlet from heat exchangers for overboard discharge - 6. Heat exchanger for gearbox oil (on request).

Description and operation

Sea water, drawn from under the keel and necessarily filtered, is drawn by the pump and sent to the supercharger air heat exchanger and from there to the water/water heat exchanger of the closed cooling loop; only after this will it flow through the heat exchanger for the gearbox oil, if one is provided.

The configuration of the discharge lines depends on the choice of a dry "chimney" exhaust, or a mixed one. The outlet pipe will carry the water directly to the overboard discharge or, if the water/exhaust gas mixer solution is adopted, a conduit will connect the outlet of the last heat exchanger with the mixer inflow junction pipe.

Sea water pump

Figure 16

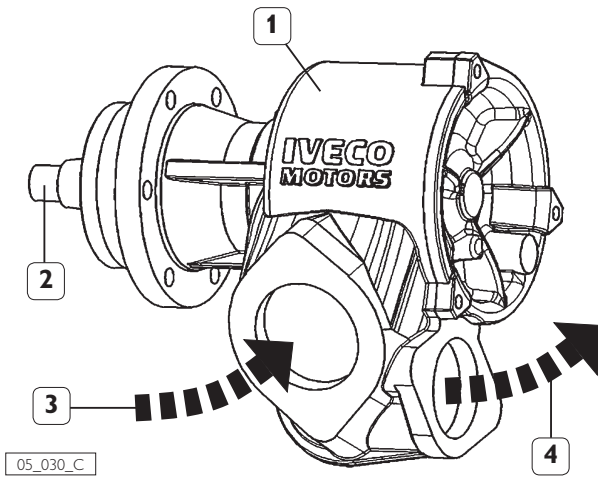

1. Pump impeller seat - 2. Driving gear shaft -
3. Sea water intake - 4. Sea water delivery.

The sea water pump, centrifugal type, is rotated by the gears keyed to the rear of the flywheel.

ENGINE OIL - LUBRICATION LOOP

Figure 17

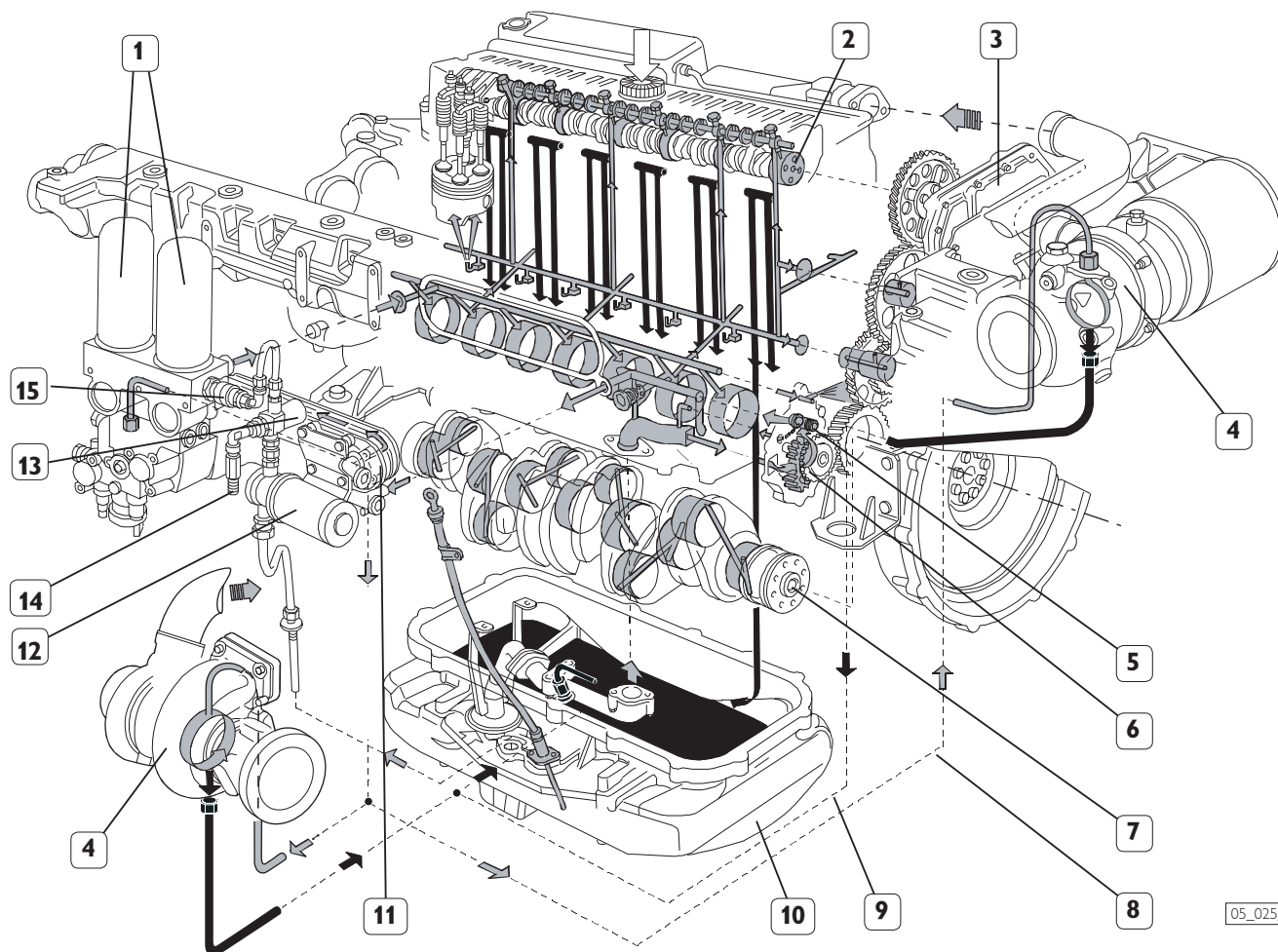

05_025_C

 Sump return oil

 Delivery oil

1. Oil filters - 2. Camshaft on cylinder head - 3. Oil vapor condenser and filter (blow by) - 4. Turbocompressor - 5. Oil pump safety valve - 6. Lubrication oil pump - 7. Drive shaft - 8. Turbocompressor lubricating oil flow line - 9. Oil return flow from turbocompressor - 10. Oil sump - 11. Heat exchanger with coolant - 12. Electrical pump for pre-lubrication and oil filling/emptying (on request) - 13. Solenoid valve for switching between the pre-lubrication or oil filling/emptying functions (on request) - 14. Oil emptying junction - 15. One-way pre-lubrication valve.

Description and operation

The gear pump, rotated by the gears at the rear of the fly-wheel sends the lubricating oil directly to the heat exchanger which, incorporated in the block and lapped by the coolant, reduces temperature to maintain optimal lubricating capability. The thermostatic valve that regulates oil flow is located at the inlet of the heat exchanger, opening the bypass pipe if temperature falls below calibration temperature.

From the output of the heat exchanger, the oil is sent to the filter assembly and from this back to the engine block to lubricate all anti-friction elements.

The blow-by vapor condenser, provided with filter and safety valve, is located on the upper part of the timing mechanism lid. The vapors, after returning to the liquid state, will flow from the vapor condenser into the sump. The engine is provided with the pre-lubrication system on request. This can inject enough oil into the engine's ducts to guarantee a totally safe start.

The operation of the electrical pre-lubrication pump (on request), is automatically controlled by the ECU electronic unit.

This system, with the aid of the flow-switching solenoid valve, also permits the oil sump to be emptied and filled.

Detailed descriptions of this operation are provided in Section 3.