



1995 TROOPER (UX) Electrical Troubleshooting Manual

Contents

How to Use This Manual	2
Troubleshooting	2-10
Fuse/Relay Information	6
Circuit Schematic (see Circuit Index)	
Component Location Photographs	201
Harness Connector Views	202
Harness Routing	203

Circuit Index (continued)

	S/LS	SE	LTD/RS
Power seats		140	140
Power windows	120	120	120
Rear window defogger	61	61	61
Rear park lights	110-1	110-1	110-1
Rear wheel anti-lock (RWAL) brake system	44		44
Seat belt warning system	73	73	73
Seat heater		147	147
Security system	Refer to Security System/Keyless Entry Technical Manual (AIMI-SSM-L0001-00)		
Shift interlock system	138	138	138
Sound system	150	150	150
Speedometer	33	33	33
Starting system			
Automatic transmission	21	21	21
Manual transmission	21-1		21-1
Sunroof		122	122
Supplemental Restraint System (SRS)	47	47	47
Tachometer	81	81	81
Trailer adapter	118	118	118
Turn lights	110-4	110-4	110-4
Vehicle speed sensor	33	33	33
Voltmeter	81-1	81-1	81-1
Wiper/washer			
Headlight			93
Rear	92	92	92
Windshield	91/91-1	91-1	91-1

Circuit Index	S/LS	SE	LTD/RS
4 wheel anti-lock brake system (ABS)	44-4	44-4	44-4
A/T shift indicator	89	89	89
Air conditioner			
Blower controls	62/62-1	62-1	62/62-1
Compressor controls	63/63-1	63-1	63/63-1
Anti-theft system			133
Automatic transmission control	39	39	39
Back up lights	112	112	112
Blower controls			
Automatic transmission	62-1	62-1	62-1
Manual transmission	62		62
Brake lights	110-8	110-8	110-8
Brake system			
4 wheel anti-lock (ABS)	44-4	44-4	44-4
Rear wheel anti-lock (RWAL)	44		44
Brake warning system			
4 wheel anti-lock (ABS)	71-1	71-1	71-1
Rear wheel anti-lock (RWAL)	71		71
Charging system	22	22	22
Cigarette lighter	155	155	155
Console lights	117	117	117
Cornering lights	110-10	110-10	110-10
Courtesy lights	114/114-2	114-2	114-2/114-1
Cruise control	34	34	34
Dash fuse box	11	11	11
Dash lights	117	117	117
Defoggers			
Door mirror	148	148	148
Rear window	61	61	61
Digital clock	154	154	154
Dome light	114/114-2	114-2	114-2/114-1
Engine coolant temperature gauge	81	81	81
Engine control	23	23	24
Fog lights		100-1	100-1
Front park lights	110	110	110
Front side marker lights	110	110	110
Fuel gauge	81-1	81-1	81-1
Gauges	81	81	81
Ground distribution	14	14	14
Hazard lights	110-4	110-4	110-4
Headlights	100	100	100
Heater	62/62-1	62	62/62-1
Horns	40	40	40
Ignition system	20	20	20
Indicators	80	80	80
Key-in ignition warning system	73	73	73
Keyless entry	Refer to Security System/Keyless Entry Technical Manual (AIMI-SSM-L0001-00)		
License plate light	110-1	110-1	110-1
Lighting switch details	12	12	12
Lights-on warning system	73	73	73
Luggage room light	114/114-2	114-2	114-2/114-1
Map lights	114-2	114-2	114-2/114-1
Oil pressure gauge	72	72	72
Oil pressure warning system	72	72	72
Power antenna			151
Power distribution	10	10	10
Power door locks	130	130	130
Power mirrors	141	141	141

All information contained in this manual is based on the latest product information available at the time of printing. We reserve the right to make changes at any time without notice. No part of this publication may be reproduced, stored in a retrieval system, or transmitted, in any form by any means, electronic, mechanical, photocopying, recording, or otherwise, without prior written permission of the publisher. This includes text, figures and tables.

How To Use This Manual

Troubleshooting Information

This manual contains the following troubleshooting information:

- Fuse Information

- Circuit Details
 - Electrical Circuit Schematic
 - Component Location Index
 - Circuit Operation
 - Quick Checks (if required)
 - Troubleshooting (if required)

- Component Location Photographs

- Harness Connector Faces

- Harness Routing Views

- Connector and Ground Cross-reference Index

The **Electrical Circuit Schematic** should always be your starting point in using this Electrical Troubleshooting Manual. The schematic shows the electrical current paths when a circuit is operating properly. It is essential to understand how a circuit *should* work before trying to figure out why it doesn't. Schematics are shown with the Starter Switch in the OFF position and other switches in the off or "at rest" position.

The **Component Location Index** helps you find where the parts of a circuit are in a vehicle. A brief statement of the location is given and also a reference to a photograph that shows the component. These Component Location Photographs are in section 201. The index also lists the number of cavities within each connector and the connector color. Not all cavities will have wires.

The **Circuit Operation** will help you to understand the circuit. It describes the components and how the circuit works.

Quick Checks (if required) offers short-cuts or checks to help you determine the cause of a complaint. They are not intended to be a rigid procedure for solving an electrical situation.

The **Troubleshooting** procedures (if required) provide a step-by-step method for locating a faulty condition.

Page Numbering

This manual is organized into sections with most sections containing circuit details. Each section has a unique number that will normally remain the same year after year. For example, the Headlights circuit will be section 100 with the first page of the section numbered 100. The following pages of this section will be numbered 100-1, 100-2, and 100-3.

Symbols

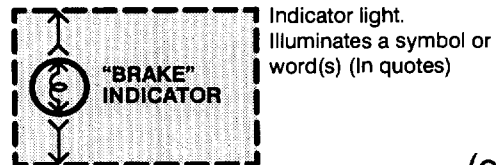
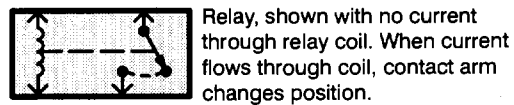
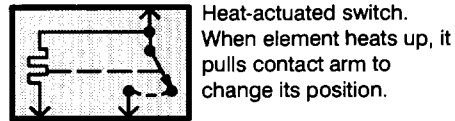
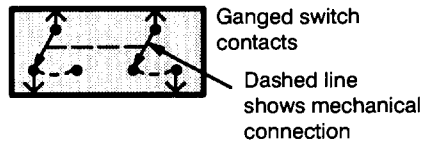
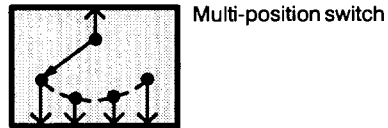
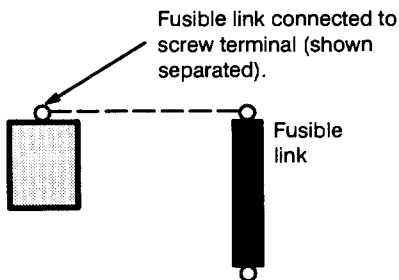
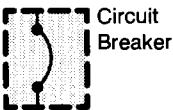
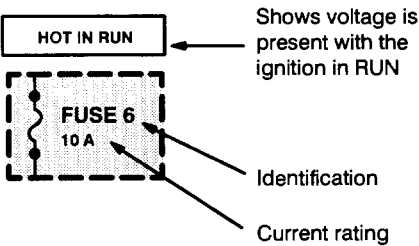
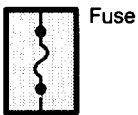
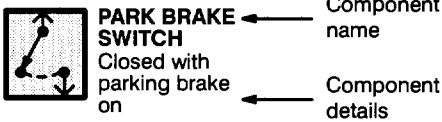
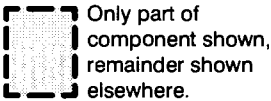

(continued)

How To Use This Manual

Symbols (continued)

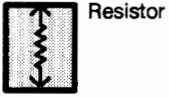

Resistor



Variable resistor



Potentiometer



Capacitor

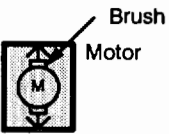

Brush
Motor

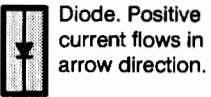

Diode. Positive current flows in arrow direction.



Light emitting diode

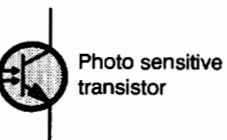
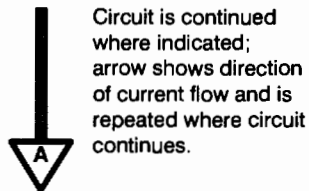
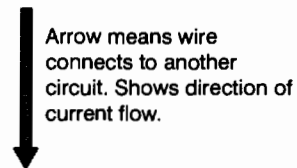
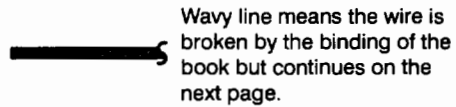
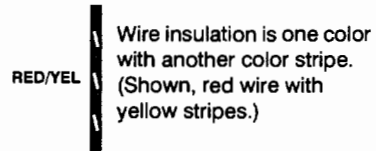
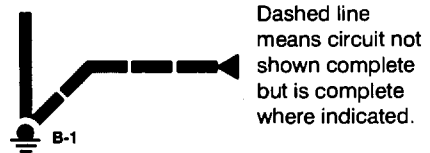
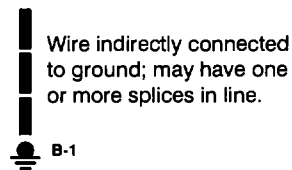
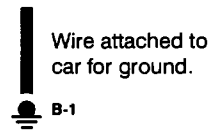
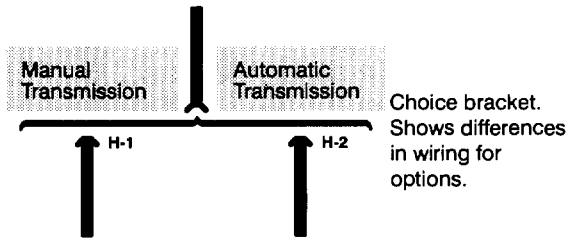
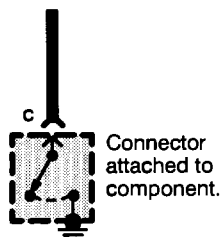
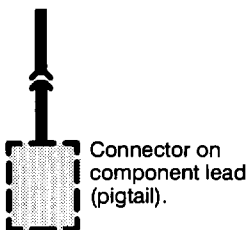
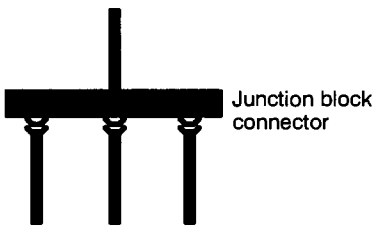
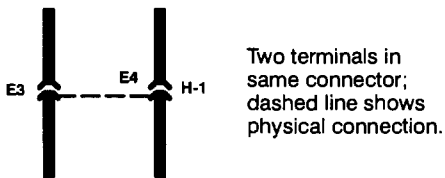
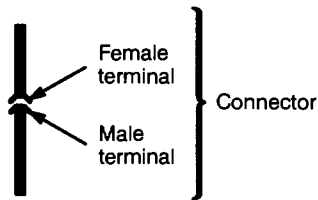
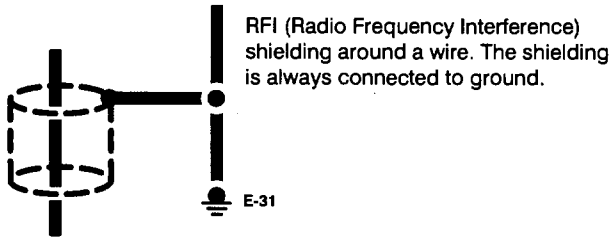
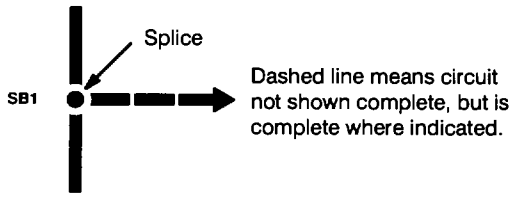

Photo sensitive transistor

BLK	black	Wire and connector colors
BLU	blue	
BRN	brown	
CLR	clear	
GRN	green	
GRY	gray	
LT BLU	light blue	
LT GRN	light green	
ORN	orange	
PNK	pink	
RED	red	
VIO	violet	
WHT	white	
YEL	yellow	





How To Use This Manual

Circuit Schematics

Circuit schematics break the entire electrical system into individual circuits. **Electrical components that work together are shown together.**

Each drawing is arranged so current flows from positive, at the top of the page, to ground, at the bottom of the page. The "hot" labels at the top of a fuse show when the ignition switch supplies power to that fuse.

Wires that connect to another circuit are shown with an arrowhead pointing in the direction of current flow. The name of the circuit that shares the wiring is provided for reference.

"See Fuse Box Details" means there are more connections to other circuits that are not shown. All such shared circuits are shown on the Fuse Box Details circuit schematic. "See Ground Distribution" means there are more shared ground circuits which are shown on the Ground Distribution schematic.

No attempt is made on the schematic to represent components and wiring as they physically appear on the car. For example, a 4 foot length of wire is treated no differently in a schematic from one which is only a few inches long. The number of cavities for each connector is listed in the Component Location Index rather than illustrated. Similarly, switches and other components are shown as simply as possible, with regard to function only.

The example on this page shows a Horns schematic. Locate the Horn schematic using the Circuit Index. The circuit schematic will look somewhat like the one to the right. The schematic is read from top to bottom.

Voltage is applied to the Horn Relay at all times. When the relay coil is grounded by closing the Horn Switch, the relay contacts close. When the relay contacts are closed, both the LH and RH Horns are energized.

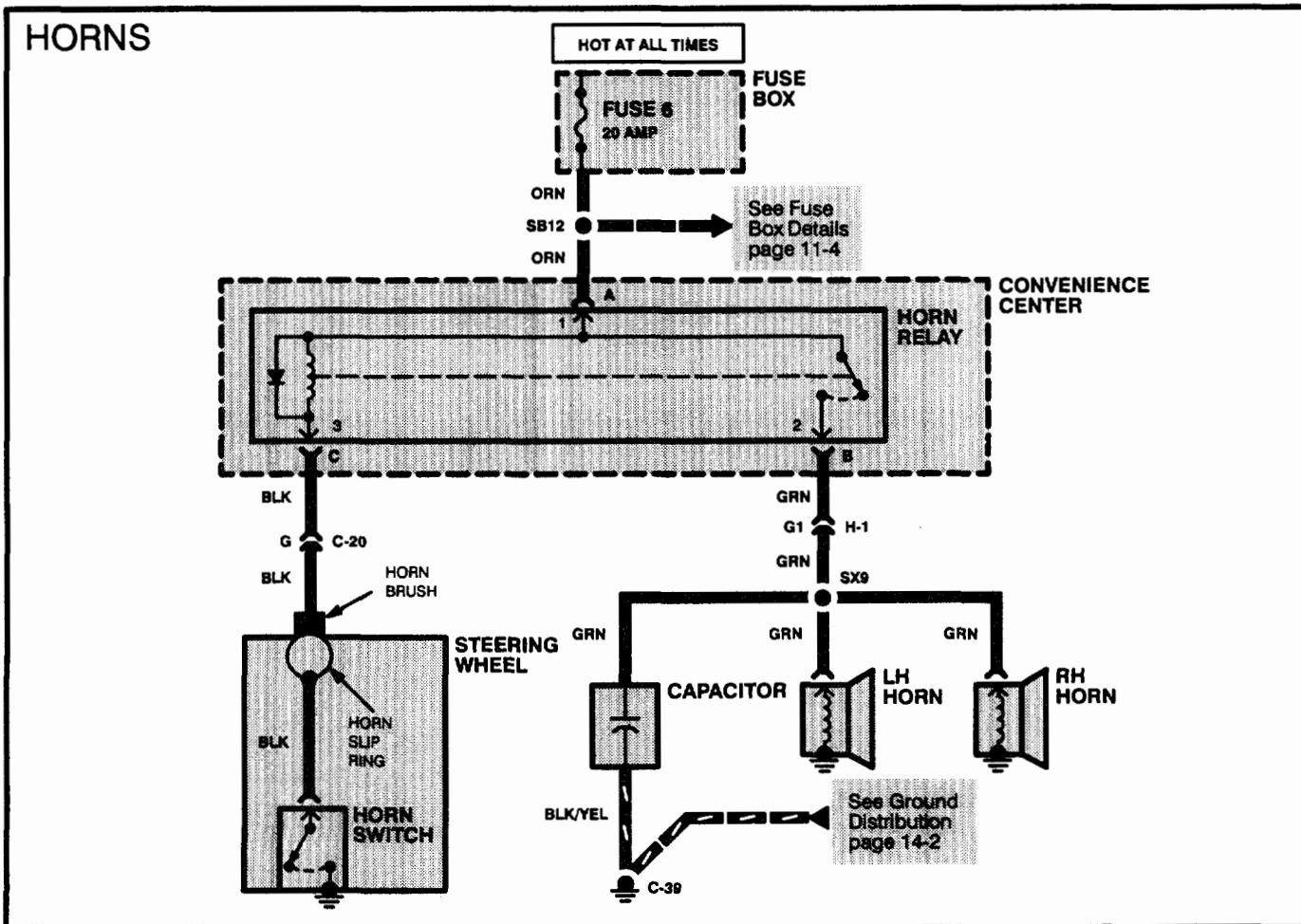

Power Distribution

The Power Distribution schematic shows the wiring from the Battery and Generator to the Starter Solenoid, Fuse Box, Ignition Switch and Light Switch. The first component after a Fusible Link is also shown. In certain instances, the first component after a Fuse Box fuse and Light Switch is also shown.

The Power Distribution schematic refers to Fuse Box Details and Light Switch Details schematics. By using

these three (3) schematics, power distribution wiring can be followed from the battery and Generator to the first component after a Fusible Link, Fuse and Light Switch. The ability to follow the power distribution wiring to the first component in each circuit is extremely helpful in locating short circuits which cause fusible links and fuses to open.

The fuses in the schematic below are "Hot At All Times," since Battery voltage is always applied to them.

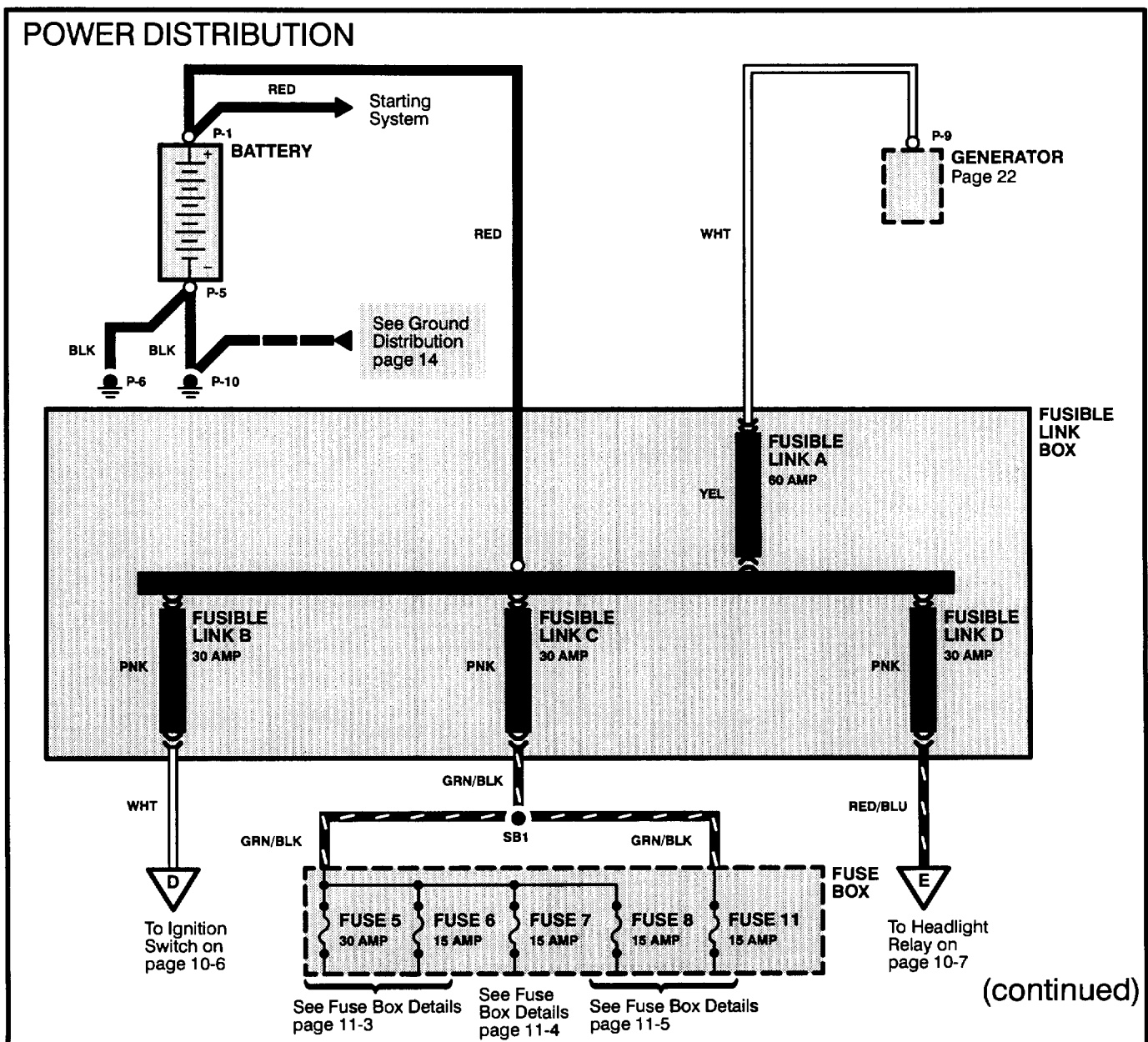

How To Use This Manual

Circuit Schematics (continued)

Fuse Box Details

The Fuse Box Details schematic shows all the wiring between a fuse and the components connected to the output of the fuse. The Fuse Box Details schematic is extremely helpful in locating a short circuit that causes a fuse to open. This schematic may aid troubleshooting an inoperative circuit by showing a second circuit using the same fuse. If the second circuit works, then the fuse and certain wires of the inoperative circuit are good.

FUSE BOX DETAILS (FUSE 1 AND FUSE 2)

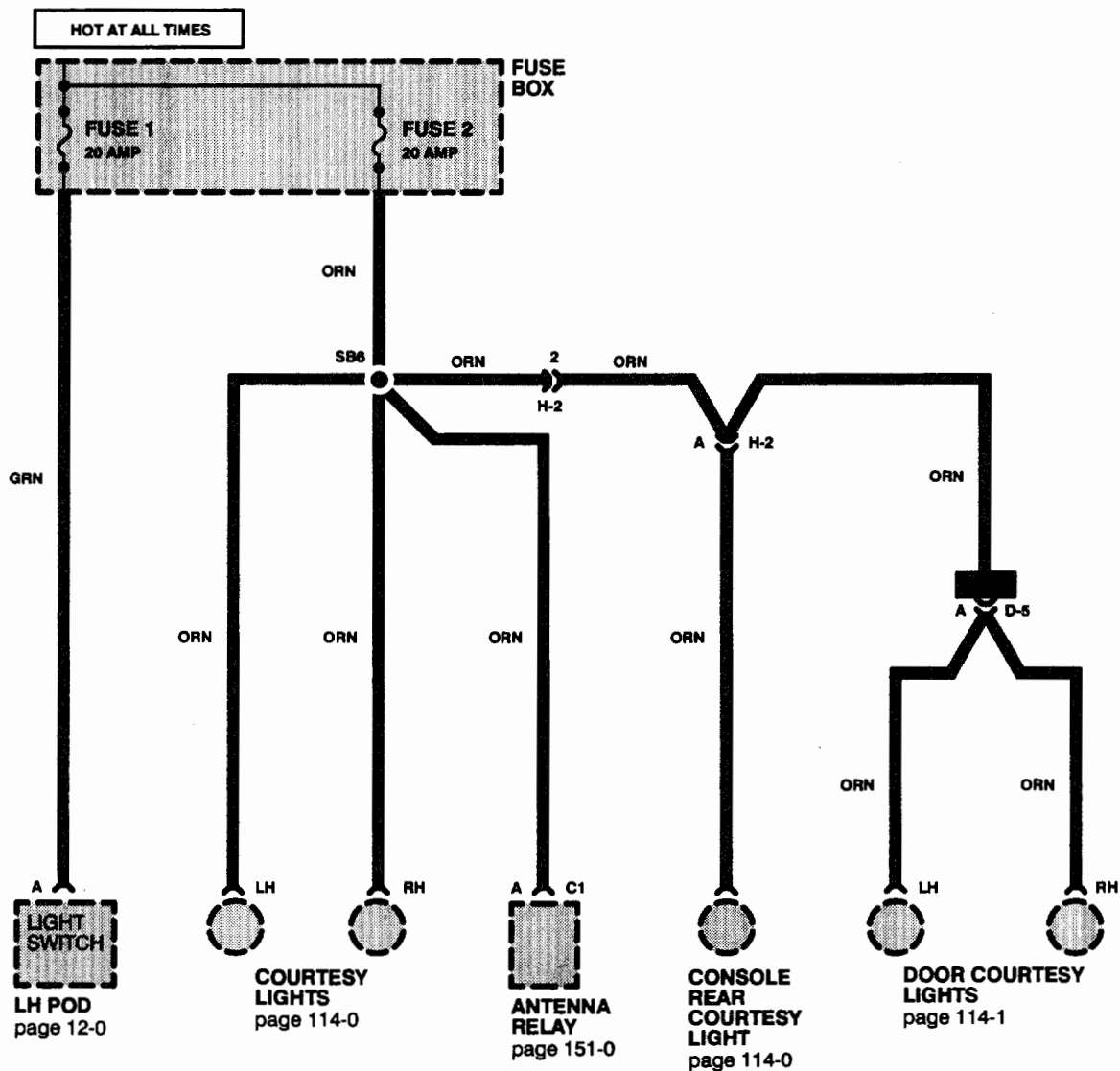

Light Switch Details

The Light Switch Details schematic shows all the wiring between the light switch/light relays and the components connected to the output of the light switch/light relays. The Light Switch Details schematic is extremely helpful in locating a short circuit on the output side of the light switch/light relays.

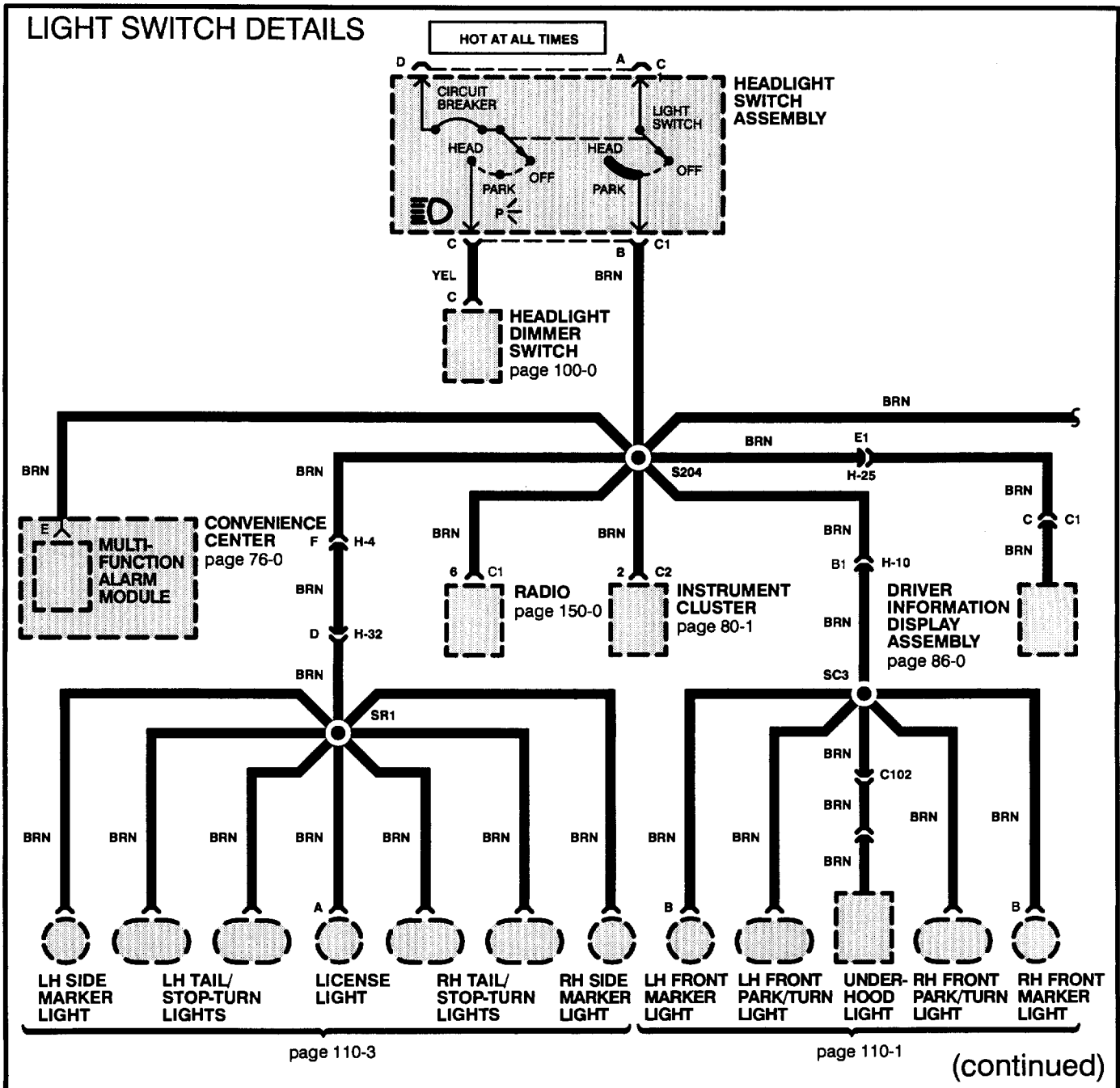

(continued)

How To Use This Manual

Circuit Schematics (continued)

Ground Distribution

The Ground Distribution schematics show which components share each ground point. This information can often be a time-saver when troubleshooting ground circuits. For example, in the schematic below, if both Headlights and the Park/Turn Light on one side are all out, you could suspect an open in their common ground wire or the ground connection

itself. On the other hand, if one of the lights works, you know that the ground and the wire up to the splice are good. You have learned this just by inspecting the schematic and knowing the vehicle's symptoms. No actual work on the lighting system was needed.

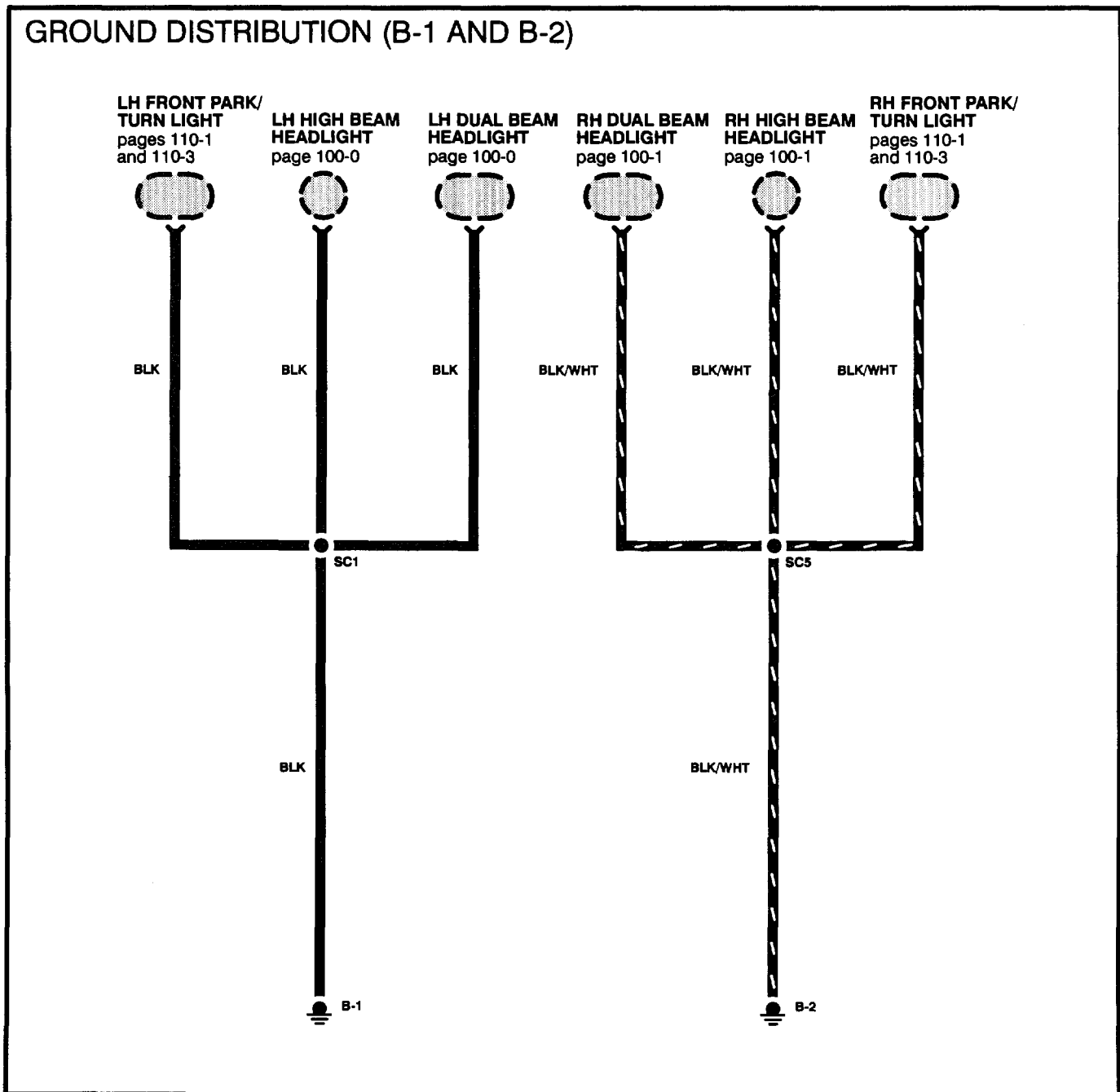

Component Location

A component location index follows each schematic. Except for the location of obvious components like Left Headlight, the index lists the location of every component, connector and ground in the schematic. The index also gives references to component location photographs located in section 201. The number of cavities in each connector and the connector color is also listed. Wires may not be used in all connector cavities.

Component Location Index

(Refer to Section 201 for photographs)

<u>Component</u>		<u>Photo No.</u>
Fuse Box	Left side of dash, behind panel	81
Left Horn	Left side of engine compartment, below headlight	15
Right Horn	Right side of engine compartment, below headlight	17
<u>Connector</u>		
B-2 (13-WHT)	Under left side of dash, above left side of steering column	71
H-41 (16-GRN)	Under left side of dash, at kick panel	63
<u>Ground</u>		
C-39	Right rear corner of engine compartment	42

How To Use This Manual

Five-Step Troubleshooting

The following five-step troubleshooting procedure is recommended.

1. Verify the Problem

Check the problem circuit's operation to be sure you understand what's wrong. Do not begin disassembly or testing until you have narrowed down the possible causes.

If the system you are troubleshooting has a built-in self-diagnostic system, refer to the appropriate section of the Service Manual.

2. Analyze the Circuit Schematic

Analyze the schematic. Read the Circuit Operation text if you do not understand how the circuit *should* work. Check circuits that share the wiring with the problem circuit. The names of circuits that share the same fuse, ground, switch, etc., are included on each electrical schematic. (Shared circuits are also shown on Power Distribution, Ground Distribution, Fuse Box Details, and Light Switch Details pages.) Try to operate the shared circuits. If these circuits work, then the shared wiring is OK. The cause must be within the wiring used only by the problem circuit. If several circuits fail at the same time, chances are the power (fuse) or ground circuit is faulty.

3. Find the Cause

- Narrow down the possible causes
- Use the Troubleshooting Hints
- Make the necessary measurements as given in the Troubleshooting procedures
- Before you replace a component, check power, signal, and ground wires at the component harness connector.

4. Repair the Problem

Once the specific problem is identified, make the repair. Be sure to use proper tools and safe procedures.

5. Check the Repair

Check the repaired circuit's operation in all modes to make sure you've fixed the entire problem. If the problem was a blown fuse, be sure to test all of the circuits on that fuse. Make sure no new problems turn up.

Test Equipment

Voltmeter and Test Light

Use a voltmeter or test light to check for voltage. While a test light shows whether or not voltage is present, a voltmeter indicates how much voltage there is.

CAUTION: A number of circuits include solid state devices. Voltages in these circuits should be tested only with a 10-megohm or higher impedance digital multimeter. Never use a test light on circuits that contain solid-state devices. Damage to the device may result.

On circuits without solid-state devices, a test light may be used to check for voltage. A test light is made up of a 12-volt bulb with a pair of leads attached. After grounding one lead, touch the other lead to various points along the circuit where voltage should be present. The bulb will go on if the voltage at the point being tested is greater than 5 volts.

Self-powered Test Light and Ohmmeter

Use a self-powered test light or ohmmeter to check for continuity. The ohmmeter shows how much resistance there is between two points along a circuit. Low resistance means good continuity.

CAUTION: Never use a self-powered test light on circuits that contain solid-state devices. Damage to these devices may result.

Diodes and solid-state devices in a circuit can make an ohmmeter give a false reading. To find out if a component is affecting a measurement, take one reading, reverse the leads, and take a second reading. If the readings differ, the component is affecting the measurement.

Circuits that contain solid-state devices should only be tested with a 10-megohm or higher impedance digital multimeter.

Troubleshooting Tests

A self-powered test light consists of a light bulb, battery and two leads. If the leads are touched together, the bulb will go on.

Self-Powered Test Light

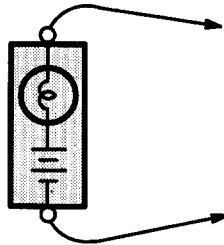

A self-powered test light is only used on an un-powered circuit. First disconnect the battery or remove the fuse that feeds the circuit you are working on. Select two points along the circuit through which there should have continuity. Connect one lead of the self-powered test light to each point. If there is continuity, the test light's circuit will be completed and the bulb will go on.

Fused Jumper Wire

Use a jumper wire to bypass an open circuit. A jumper wire is made up of an in-line fuse holder connected to a set of test leads. It should have a five ampere fuse. Never use a jumper wire across any load. This direct battery short will blow the fuse.

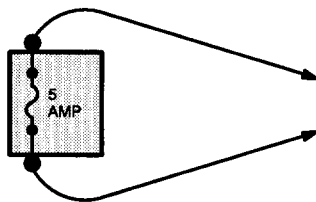

Short Finder

Short finders are available to locate shorts to ground. The short finder creates a pulsing magnetic field in the shorted circuit and shows you the location of the short through body trim or sheet metal. Its use is explained in the following troubleshooting tests.

Testing For Voltage

This test measures voltage in a circuit. When testing for voltage at a connector, you may not have to separate the two halves of the connector. Instead, probe the connector from the back. Always check both sides of the connector because dirt and corrosion between its contact surfaces can cause electrical problems.

1. Connect one lead of test light to known good ground, or if you are using a voltmeter, be sure you connect its negative lead to ground.
2. Connect the other lead of the test light or voltmeter to the point you want to check.
3. If the test light glows, there is voltage present. If you are using a voltmeter, note the voltage reading. It should be within one volt of measured battery voltage. A loss of more than one volt indicates a problem.

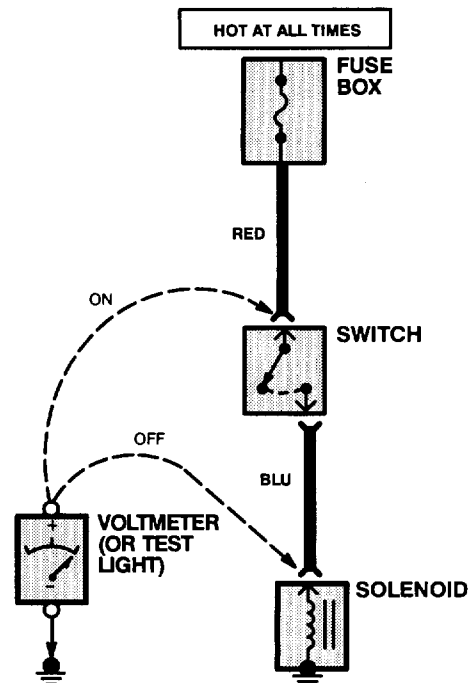

(continued)

How To Use This Manual

Troubleshooting Tests (continued)

Testing For Continuity

This test checks for continuity within a circuit. When testing for continuity at a connector, you may not have to separate the two halves of the connector. Instead, probe the connector from the back. Always check both sides of the connector because dirt and corrosion between contact surfaces can cause electrical problems.

1. Disconnect the negative cable from the car battery.
2. If you are using an ohmmeter, hold the leads together and adjust the ohmmeter to read zero ohms.
3. Connect one lead of self-powered test light or ohmmeter to one end of the part of the circuit you wish to test.
4. Connect the other lead to the other end.
5. If the self-powered test light glows, there is continuity. If you're using an ohmmeter, low or no resistance means good continuity.

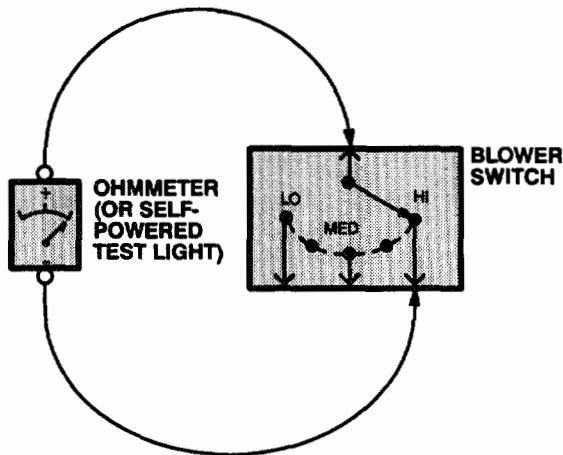

Testing For Voltage Drop

This test checks for voltage drop along a wire, or through a connection or switch.

1. Connect the positive lead of a voltmeter to the end of the wire (or to the side of the connector or switch) closest to the battery.
2. Connect the negative lead to the other end of the wire (or the other side of the connector or switch).
3. Operate the circuit.
4. The voltmeter will show the difference in voltage between the two points. A difference, or drop of more than 0.5 volts may indicate a problem. Check the circuit for loose or dirty connections.

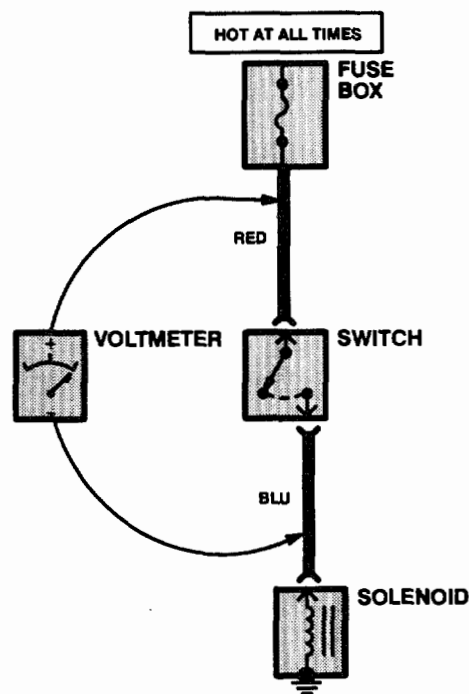

Testing For A Short To Ground With A Test Light Or Voltmeter

1. Remove the blown fuse and disconnect the load.
2. Connect a test light or voltmeter across the fuse terminals. Make sure voltage is being applied to the battery side fuse terminal. Check schematic to see if the ignition switch needs to be in RUN.
3. Beginning near the fuse box, wiggle the harness. Continue this at convenient points about six inches apart while watching the test light or voltmeter.
4. When the test light blinks or the voltmeter needle moves, there is a short to ground in the wiring near that point.

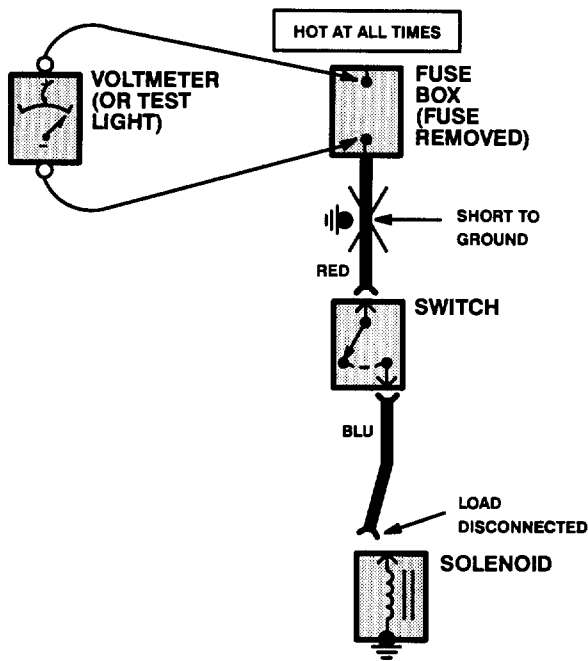

Testing For A Short To Ground With A Self-Powered Test Light Or Ohmmeter

1. Remove the blown fuse and disconnect the battery and load.
2. Connect one lead of a self-powered test light or ohmmeter to the fuse terminal load side.
3. Connect the other lead to a known good ground.
4. Beginning near the fuse box, wiggle the harness. Continue this at convenient points about six inches apart while watching the test light or ohmmeter.
5. If the self-powered test light blinks or the ohmmeter needle moves, there is a short to ground in the wiring near that point.

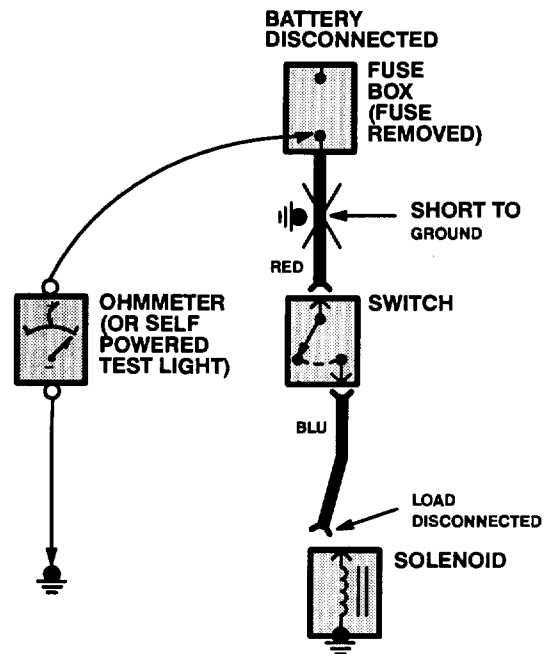

How To Use This Manual

Troubleshooting Information

Page Numbering

Testing For A Short To Ground With A Short Finder

1. Remove the blown fuse. Leave the battery connected.
2. Connect the short finder between the positive battery terminal and the load side fuse terminal.
3. Close all switches in series with the wire you are troubleshooting.
4. Turn on the short finder. It sends pulses of current to the short. This creates a pulsing magnetic field around the wiring between the fuse box and the short.
5. Beginning at the fuse box, slowly move the short finder meter along the circuit wiring. The meter will show current pulses through sheet metal and body trim. As long as the meter is between the fuse and the short, the needle will move with each current pulse. Once you move the meter past the point of the short, the needle will stop moving. Check around this area to locate the cause of the short circuit.

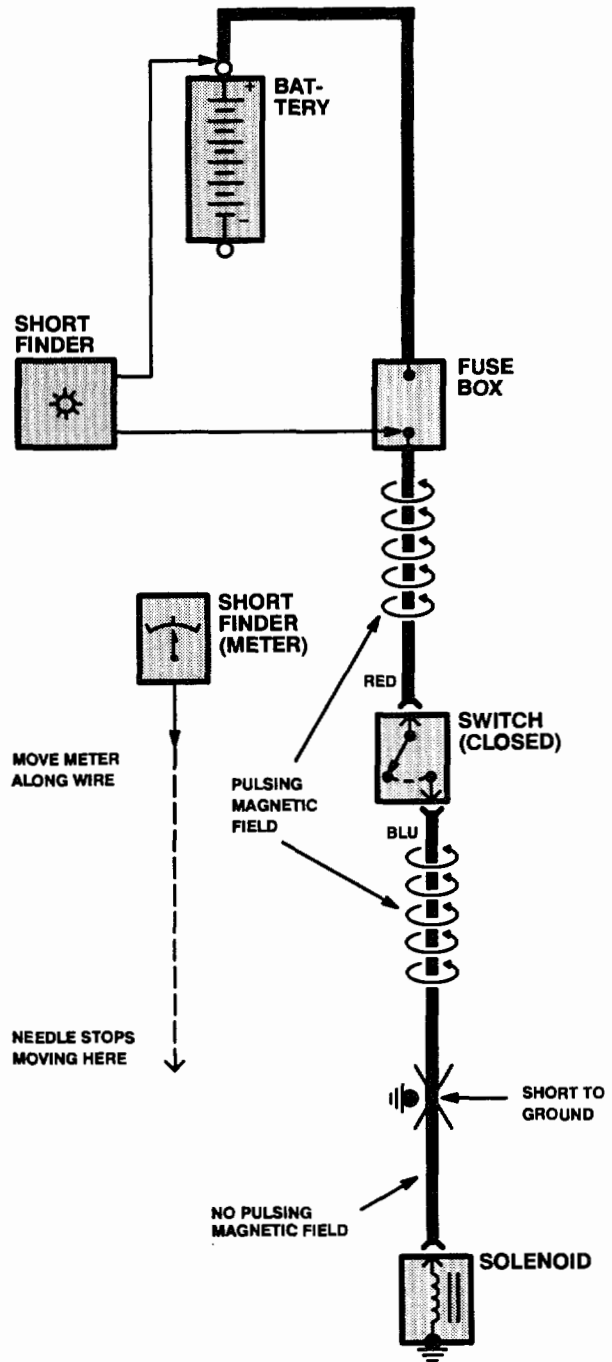

FUSE/RELAY INFORMATION

Dash and SRS Fuse Boxes

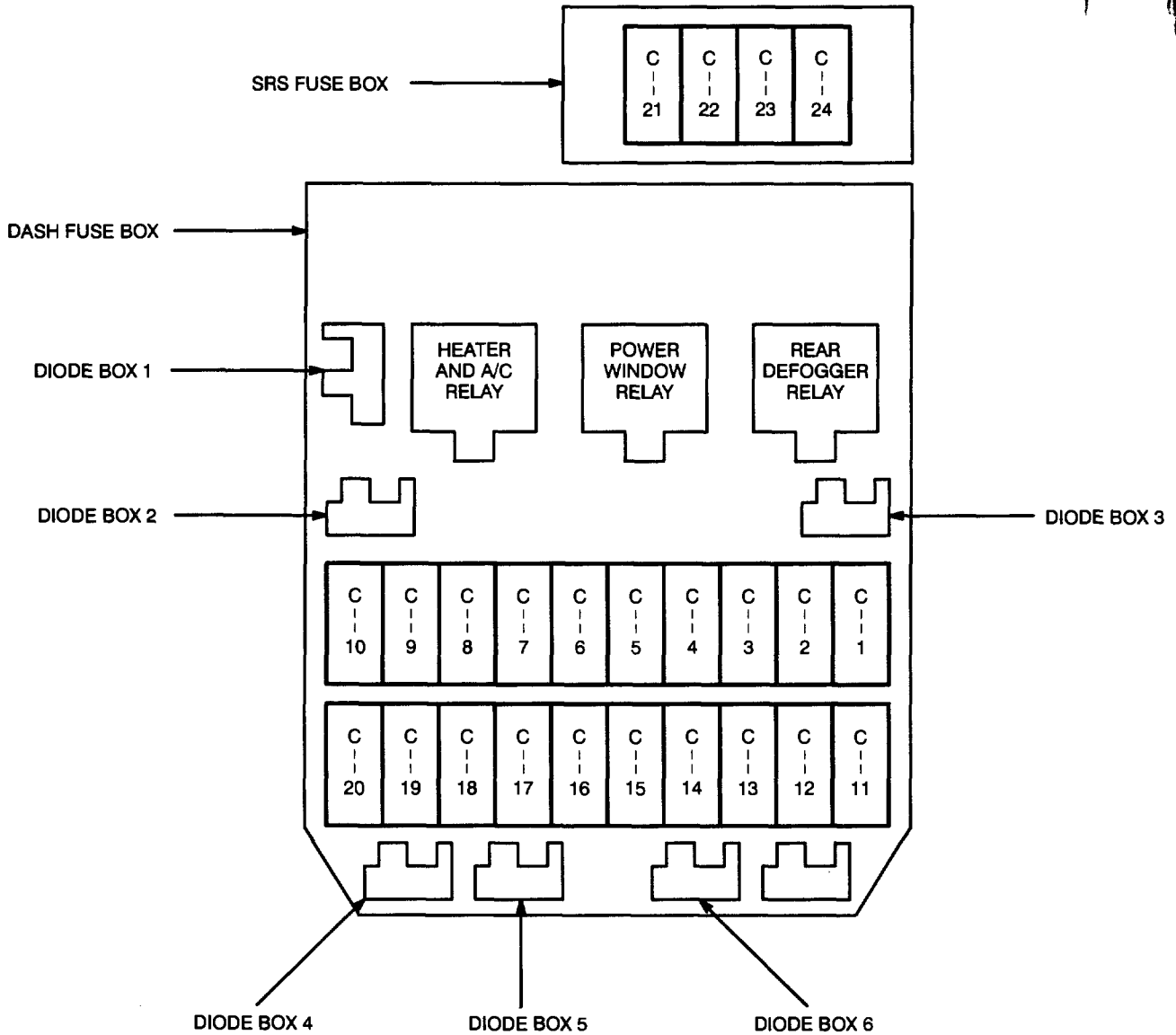

Fuse Number	Fuse Name	Amps	Circuit Protected
C-1	STARTER RELAY	10	Starting system; blower controls; A/C: compressor controls; supplemental restraint system (SRS)
C-2	(SEAT HEATER)	15	Seat heater
C-3	TURN BACK	15	Back up lights; turn lights; hazard lights; cornering lights; A/T shift indicator
C-4	ELEC. IGN.	10	Rear defogger; cruise control; power windows; engine control; door mirror defoggers; shift interlock system; power sunroof; 4-wheel anti-lock brake system (ABS)
C-5	FRT WIPER & WASHER	15	Windshield wiper/washer
C-6	RR WIPER & WASHER	10	Rear wiper/washer
C-7	(H/LAMP WIPER)	10	Headlight wiper/washer
C-8	ENGINE	15	Engine control; charging system
C-9	IGN. COIL	15	Ignition system
C-10	METER GAUGE	10	Gauges; indicators
C-11	(AUDIO [ACC]) MIRROR	10	Sound system; power mirrors; clock
C-12	CIGARETTE	20	Cigarette lighter
C-13	(ANTI THEFT)	10	Anti-theft system
C-14	STOP A/T CONT	15	Brake lights; automatic transmission control; shift interlock system; rear wheel anti-lock (RWAL) brake system
C-15	(AUDIO [B])	20	Sound system
C-16	CLOCK [B] ROOM	10	Sound system; interior lights; key-in ignition warning system; anti-theft system; auto antenna; clock
C-17	RR DEFOG	25	Rear defogger
C-18	(DOOR LOCK)	20	Power door locks; anti-theft system; power windows
C-19	BLOWER	25	Blower controls
C-20	(AIR CON)	10	A/C: compressor controls
C-21	SRS-1	10	Supplemental restraint system (SRS)
C-22	SRS-2	10	Supplemental restraint system (SRS)
C-23	SRS-3	10	Supplemental restraint system (SRS)
C-24	SRS-4	10	Supplemental restraint system (SRS)

Circuit Breaker Number	Circuit Breaker Name	Amps	Circuit Protected
C/B-1	—	—	Not used
C/B-2	(P/W, P/S, S/R)	30	Power windows; power sunroof; power seats; power door locks

FUSE/RELAY INFORMATION

Fuse/Relay Box

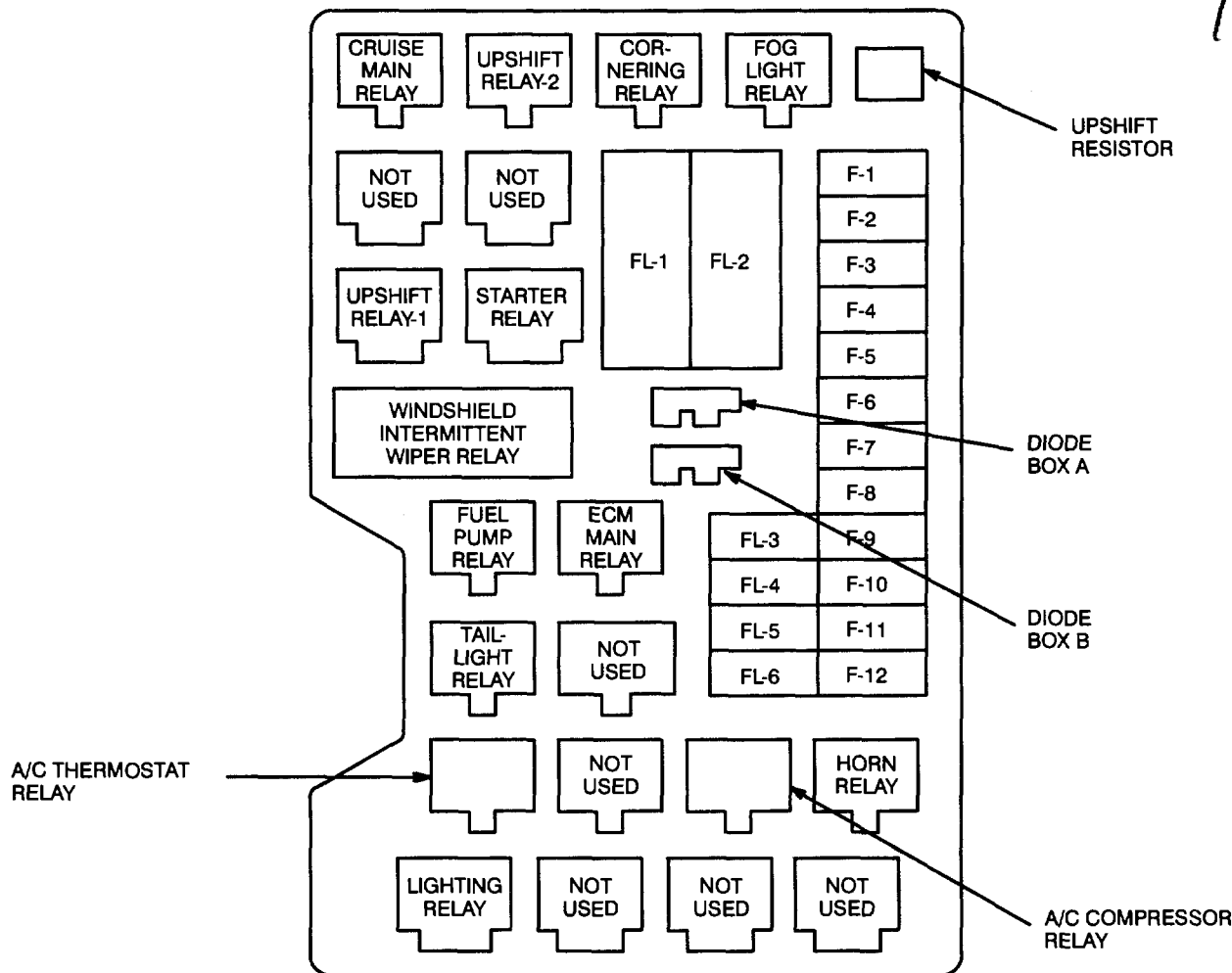

Fuse Number	Fuse Name	Amps	Circuit Protected
F-1	—	—	Not used
F-2	O ₂ SENSOR HEATER	10	Engine control
F-3	HORN HAZARD	15	Horns; Hazard light
F-4	H/LAMP—LH	15	Headlights and fog lights
F-5	H/LAMP—RH	15	Headlights
F-6	—	—	Not used
F-7	—	—	Not used
F-8	(FRT. FOG)	15	Fog lights
F-9	ABS	20	Rear wheel anti-lock (RWAL) brake system or anti-lock brake system (ABS)
F-10	FUEL PUMP	15	Engine control
F-11	—	—	Not used
F-12	TAIL	15	Taillights