

**INDUSTRIAL
DIESEL ENGINE
A-4JA1, A-4JB1
MODELS**

WORKSHOP MANUAL

©2003 ISUZU MOTORS LIMITED

FOREWORD

This Workshop Manual is designed to help you perform necessary maintenance, service, and repair procedures on applicable Isuzu industrial engines.

Information contained in this Workshop Manual is the latest available at the time of publication.

Isuzu reserves the right to make changes at any time without prior notice.

This Workshop Manual is applicable to 1998 and later models.

NOTICE

Before using this Workshop Manual to assist you in performing engine service and maintenance operations, it is recommended that you carefully read and thoroughly understand the information contained in Section - 1 under the headings "General Repair Instruction" and "Notes on The Format of This Manual"

TABLE OF CONTENTS

SECTION 1.	GENERAL INFORMATION.....	1
SECTION 2.	MAINTENANCE	17
SECTION 3.	ENGINE ASSEMBLY (1)	29
	(DISASSEMBLY)	
SECTION 4.	ENGINE ASSEMBLY (2)	47
	(INSPECTION AND REPAIR)	
SECTION 5.	ENGINE ASSEMBLY (3)	81
	(REASSEMBLY)	
SECTION 6.	LUBRICATING SYSTEM.....	109
SECTION 7.	COOLING SYSTEM	121
SECTION 8.	FUEL SYSTEM.....	133
SECTION 9.	ENGINE ELECTRICALS.....	147
SECTION 10.	TROUBLESHOOTING.....	175
SECTION 11.	SPECIAL TOOL LIST	201
SECTION 12.	REPAIR STANDARDS	205
SECTION 13.	CONVERSION TABLE.....	219

SECTION 1

GENERAL INFORMATION

TABLE OF CONTENTS

ITEM	PAGE
General repair instructions	2
Notes on the format of this manual	2
Main data and specifications	6
Tightening torque specifications	7

GENERAL REPAIR INSTRUCTIONS

1. Before performing any service operation with the engine mounted, disconnect the grounding cable from the battery.
This will reduce the chance of cable damage and burning due to short circuiting.
2. Always use the proper tool or tools for the job at hand.
Where specified, use the specially designed tool or tools.
3. Use genuine ISUZU parts.
4. Never reuse cotter pins, gaskets, O-rings, lock washers, and self locking nuts. Discard them as you remove them. Replace them with new ones.
5. Always keep disassembled parts neatly in groups. This will ensure a smooth reassembly operation.
It is especially important to keep fastening parts separate. These parts vary in hardness and design, depending on their installation position.
6. All parts should be carefully cleaned before inspection or reassembly.
Oil ports and other openings should be cleaned with compressed air to make sure that they are completely free of obstructions.
7. Rotating and sliding part surfaces should be lubricated with oil or grease before reassembly.
8. If necessary, use a sealer on gaskets to prevent leakage.
9. Nut and bolt torque specifications should be carefully followed.
10. Always release the air pressure from any machine-mounted air tank(s) before dismounting the engine or disconnecting pipes and hoses. To not do so is extremely dangerous.
11. Always check and recheck your work. No service operation is complete until you have done this.

NOTES ON THE FORMAT OF THIS MANUAL

This Workshop Manual is applicable to ISUZU industrial engine or engines which is or are stated in the title.

When more than two engine models are dealt in the manual, such engines have common parts and components as well as data and specifications, unless otherwise specified.

1. Find the applicable section by referring to the Table of Contents at the beginning of the Manual.
2. Common technical data such as general maintenance items, service specifications, and tightening torques are included in the "General Information" section.
The section ENGINE ASSEMBLY is an exception. This parts are divided in three sections to facilitates indexing.
3. Each section is divided into sub-sections dealing with disassembly, inspection and repair, and reassembly.

4. When the same servicing operation is applicable to several different units, the manual will direct you to the appropriate page.
5. For the sake of brevity, self-explanatory removal and installation procedures are omitted. More complex procedures are covered in detail.
6. Each service operation section in this Workshop Manual begins with an exploded view of the applicable area. A brief explanation of the notation used follows.

Disassembly Steps - 2

1. Water by-pass hose	10. Cylinder head gasket
2. Thermostat housing	▲ 11. Crankshaft damper pulley with dust seal
3. Water pump	12. Timing gear case cover
▲ 4. Injection nozzle holder	13. Timing gear cover
5. Glow plug and glow plug connector	14. Timing gear oil pipe
6. Cylinder head cover	15. Idler gear "B" and shaft
▲ 7. Rocker arm shaft and rocker arm	16. Idler gear "A"
8. Push rod	▲ 17. Idler gear shaft
▲ 9. Cylinder head	

Inverted Engine

- Parts marked with an asterisk (*) are included in the repair kit.
- Parts within a square frame are to be removed and installed as a single unit, and their disassembly steps or reassembly steps are shown in the illustrations respectively.
- The number tells you the service operation sequence.
- Removal of unnumbered parts is unnecessary unless replacement is required.
- The "* Repair Kit" indicates that a repair kit is available.
- The parts listed under "Disassembly Steps" or "Reassembly Steps" are in the service operation sequence.
- The removal or installation of parts marked with a triangle (▲) is an important operation. Detailed information is given in the text.

GENERAL INFORMATION

7. Below is a sample of the text of the Workshop Manual.

4. Camshaft Timing Gear

- 1) Install the thrust plate ①.
- 2) Apply engine oil to the bolt threads ②.
- 3) Install the camshaft timing gear with the timing mark stamped side facing out.

Camshaft Timing Gear Bolt Torque kgf·m(lb.ft/N·m)

11.0 ± 1.0 (79.5 ± 7.2/107.8 ± 9.8)

13. Crankshaft Rear Oil Seal

- 1) Apply engine oil to the oil seal lip circumference and the oil seal outer circumference.
- 2) Use the oil seal installer to install the oil seal to the cylinder body.

Oil Seal Installer: 5-8840-0141-0

14. Flywheel Housing

- 1) Apply liquid gasket to the shaded area shown in the illustration.
- 2) Tighten the flywheel housing bolts to the specified torque a little at a time in the sequence shown in the illustration.

Flywheel Housing Bolt Torque kgf·m(lb.ft/N·m)

M10x1.25 (0.40x0.05) Bolt	5.6±1.0 (40.5±7.2/ 54.9±9.8)
M12x1.25 (0.47x0.05) Bolt	10.5±1.0 (76.0±7.2/103.0±9.8)
M12x1.75 (0.47x0.07) Bolt	9.8±1.0 (71.0±7.2/ 96.0±9.8)

This is the item shown in the illustration. It is marked with a triangle (▲) on the Major Components page.

Letters and numbers contained in a circle refer to the illustration.

Special tools are identified by the tool name and/or number. The illustration shows how the special tool is to be used.

Symbols indicate the type of service operation or step to be performed. A detailed explanation of these symbols follows.

Service data and specifications are given in this table.

8. The following symbols appear throughout this Workshop Manual. They tell you the type of service operation or step to perform.



.... Removal



.... Adjustment



.... Installation



.... Cleaning



.... Disassembly



.... Important operation requiring extra care



.... Reassembly



.... Specified torque (tighten)



.... Alignment (marks)



.... Special tool use required or recommended (Isuzu tool or tools)



.... Directional indication



.... Commercially available tool use required or recommended



.... Inspection



.... Lubrication (oil)



.... Measurement



.... Lubrication (grease)



.... Sealant application

9. Measurement criteria are defined by the terms "standard" and "limit".

A measurement falling within the "standard" range indicates that the applicable part or parts are serviceable.

"Limit" should be thought of as an absolute value.

A measurement which is outside the "limit" indicates that the applicable part or parts must be either repaired or replaced.

10. Components and parts are listed in the singular form throughout the Manual.

11. Directions used in this Manual are as follows:

Front

The cooling fan side of the engine viewed from the flywheel.

Right

The right hand side viewed from the same position.

Left

The left hand side viewed from the same position.

Rear

The flywheel side of the engine.

Cylinder numbers are counted from the front of the engine.

The front most cylinder is No. 1 and rear most cylinder is the final cylinder number of the engine.

The engine's direction of rotation is counterclockwise viewed from the flywheel.

MAIN DATA AND SPECIFICATIONS

Engine Model		A-4JA1	A-4JB1	4JB1T
Item				
Engine type		Water cooled, four-cycle, in-line, overhead valve		
Combustion chamber type		Direct injection		
Cylinder liner type		Dry		
No. of cylinders - Bore x Stroke	mm(in.)	4 - 93.0 x 92.0 (3.66 x 3.62)	4 - 93.0 x 102.0 (3.66 x 4.02)	4 - 93.0 x 102.0 (3.66 x 4.02)
Total piston displacement	lit(cid)	2.449 (152.4)	2.771 (169.0)	2.771 (169.0)
Compression ratio (To 1)		18.4	18.2	18.2
*Engine dimensions	mm(in.)	805 x 625 x 729	739 x 625 x 746	578 x 771 x 577
Length x Width x Height		(31.7 x 24.6 x 28.7)	(29.1 x 24.6 x 29.4)	(22.8 x 30.4 x 22.7)
*Engine weight (Dry)	kg(lb.)	218 (480)	220 (486)	245 (540)
Fuel injection order		1 - 3- 4 - 2		
*Fuel injection timing (B.T.D.C.)	degrees	14		
Specified fuel		Diesel fuel		
Injection pump		In-line plunger, Bosch A type		Bosch distributor VE type
Governor		Variable speed mechanical type		
*Low idle speed	rpm	850 - 1,000		
Injection nozzle		Multi-hole type		
Injection starting pressure	kgf/cm ² (psi/MPa)	185 (2630/18.1)		
Fuel filter type		Cartridge papaer element		
Water sedimentor (if so equipped)		Sediment/water level indicating type		
Compression pressure	kgf/cm ² (psi/MPa)	31 (441/3.04)		
Valve clearance (at cold)	Intake mm(in.)	0.40 (0.0157)		
	Exhaust mm(in.)	0.40 (0.0157)		
Lubrication method		Pressurized circulation		
Oil pump		Trochoid type		
Main oil filter type		Cartridge paper element, full flow		
Partial oil filter		Not equipped		
*Lubricating oil volume	lit.(qts)	5.5 (5.8) - 6.6 (7.0)	4.6 (4.9) - 6.4 (6.8)	4.6 (4.9) - 6.3 (6.7)
Oil cooler (if so equipped)		Water cooled built in oil filter		
Cooling method		Pressurized forced circulation		
Coolant volume	lit.(qts)	5.0 (5.3)		
Water pump		Belt driven impeller type		
Thermostat type		Wax pellet type		
*Alternator	V-A	12 - 35		
*Starter	V-kW	12 - 2.2		









Specifications marked with an asterisk (*) will vary according to engine application.

TIGHTENING TORQUE SPECIFICATIONS

The tightening torque values given in the table below are applicable to the bolts unless otherwise specified.

STANDARD BOLT

kgf·m (lb.ft/N·m)

Strength Class Bolt Identification	4.8 (4T)	(7T)	8.8		9.8 (9T)
			Refined	Non-Refined	
Bolt Diameter × pitch (mm)					
	 No mark	—			
M 6 × 1.0	0.4 – 0.8 (2.9 – 5.8/3.9 – 7.8)		0.5 – 1.0 (3.6 – 7.2/4.9 – 9.8)		—
M 8 × 1.25	0.8 – 1.8 (5.8 – 13.0/7.8 – 17.7)		1.2 – 2.3 (8.7 – 16.6/11.8 – 22.6)		1.7 – 3.1 (12.3 – 22.4/16.7 – 30.4)
M10 × 1.25	2.1 – 3.5 (15.2 – 25.3/20.6 – 34.3)		2.8 – 4.7 (20.3 – 34.0/27.5 – 46.1)		3.8 – 6.4 (27.5 – 46.3/37.3 – 62.8)
M12 × 1.25	5.0 – 7.5 (36.2 – 54.2/49.0 – 73.6)		6.2 – 9.3 (44.8 – 67.3/60.8 – 91.2)		7.7 – 11.6 (55.7 – 83.9/75.5 – 113.8)
M14 × 1.5	7.8 – 11.7 (56.4 – 84.6/78.5 – 114.7)		9.5 – 14.2 (68.7 – 102.7/93.2 – 139.3)		11.6 – 17.4 (83.9 – 125.6/113.8 – 170.6)
M16 × 1.5	10.6 – 16.0 (76.7 – 115.7/103.0 – 156.9)		13.8 – 20.8 (99.8 – 150.4/135.3 – 204.0)		16.3 – 24.5 (118.9 – 177.2/159.9 – 240.3)
M18 × 1.5	15.4 – 23.0 (111.1 – 166.4/151.0 – 225.6)		19.9 – 29.9 (143.9 – 216.3/195.2 – 391.3)		23.4 – 35.2 (169.3 – 254.6/229.5 – 345.2)
M20 × 1.5	21.0 – 31.6 (151.9 – 228.6/205.9 – 307.9)		27.5 – 41.3 (198.9 – 298.7/269.7 – 405.0)		32.3 – 48.5 (233.6 – 350.8/316.8 – 475.6)
M22 × 1.5	25.6 – 42.2 (185.2 – 305.2/251.1 – 413.8)		37.0 – 55.5 (267.6 – 401.4/362.9 – 544.3)		43.3 – 64.9 (313.2 – 469.4/424.6 – 636.5)
M24 × 2.0	36.6 – 55.0 (264.7 – 397.8/358.9 – 539.4)		43.9 – 72.5 (317.5 – 523.9/430.5 – 711.0)		56.5 – 84.7 (408.7 – 612.6/554.1 – 830.6)
*M10 × 1.5	2.0 – 3.4 (14.5 – 24.6/19.6 – 32.4)		2.8 – 4.6 (20.3 – 33.3/27.5 – 45.1)		3.7 – 6.1 (26.8 – 44.1/36.3 – 59.8)
*M12 × 1.5	4.6 – 7.0 (33.3 – 50.6/45.1 – 68.7)		5.8 – 8.6 (42.0 – 62.2/56.9 – 84.3)		7.3 – 10.9 (52.8 – 78.8/71.6 – 106.9)
*M14 × 2.0	7.3 – 10.9 (52.8 – 78.8/71.6 – 106.9)		9.0 – 13.4 (65.1 – 96.9/88.3 – 131.4)		10.9 – 16.3 (78.8 – 118.9/106.9 – 159.9)
*M16 × 2.0	10.2 – 15.2 (73.8 – 110.0/100.0 – 149.1)		13.2 – 19.8 (95.5 – 143.2/129.5 – 194.2)		15.6 – 23.4 (112.8 – 169.3/162.8 – 229.5)

An asterisk (*) indicates that the bolts are used for female threaded parts that are made of soft materials such as casting. Those shown in parentheses in the strength class indicate the classification by the old standard.

TIGHTENING TORQUE SPECIFICATIONS

The tightening torque values given in the table below are applicable to the bolts unless otherwise specified.

FLANGED HEAD BOLT

kgf·m (lb.ft/N·m)

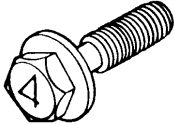
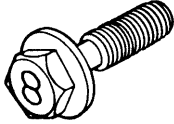
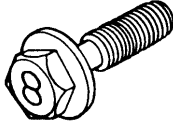
Bolt head marking Nominal size (dia. x pitch)			
M 6 × 1	0.5 – 0.9 (3.61 – 6.50/4.6 – 8.5)	0.6 – 1.2 (4.33 – 8.67/5.88 – 11.76)	—
M 8 × 1.25	1.1 – 2.0 (7.95 – 14.46/10.78 – 19.61)	1.4 – 2.9 (4.33 – 8.67/5.88 – 11.76)	1.9 – 3.4 (13.74 – 24.59/18.63 – 33.34)
M10 × 1.25	2.3 – 3.9 (17.35 – 28.20/23.53 – 38.24)	3.6 – 6.4 (26.03 – 44.12/35.30 – 59.82)	4.3 – 7.2 (31.10 – 52.07/42.16 – 70.60)
*M10 × 1.5	2.3 – 3.8 (16.63 – 27.48/22.55 – 37.26)	3.5 – 5.8 (25.31 – 41.95/34.32 – 56.87)	4.1 – 6.8 (29.65 – 49.18/40.20 – 66.68)
M12 × 1.25	5.6 – 8.4 (40.50 – 60.75/54.91 – 82.37)	7.9 – 11.9 (57.14 – 86.07/77.47 – 116.69)	8.7 – 13.0 (62.92 – 94.02/85.31 – 127.48)
*M12 × 1.75	3.5 – 9.5 (37.61 – 56.41/50.99 – 76.49)	7.3 – 10.9 (52.80 – 78.83/71.58 – 106.89)	8.1 – 12.2 (58.58 – 88.24/79.43 – 119.64)
M14 × 1.5	8.5 – 12.7 (61.48 – 91.85/83.35 – 124.54)	11.7 – 17.6 (84.62 – 127.30/114.73 – 172.59)	12.6 – 18.9 (91.13 – 136.70/123.56 – 185.34)
*M14 × 2	7.6 – 11.5 (57.14 – 85.34/77.47 – 115.71)	11.1 – 16.6 (80.28 – 120.06/108.85 – 162.79)	11.8 – 17.7 (85.34 – 128.02/115.71 – 173.57)
M16 × 1.5	11.8 – 17.7 (85.34 – 128.02/115.71 – 173.57)	17.1 – 26.5 (125.85 – 189.50/170.63 – 256.93)	18.0 – 27.1 (130.19 – 196.01/176.52 – 265.76)
*M16 × 2	11.2 – 16.7 (81.00 – 120.79/109.83 – 163.77)	16.6 – 24.9 (120.06 – 180.10/162.79 – 244.18)	17.2 – 25.7 (124.40 – 186.61/168.67 – 253.01)

A bolt with an asterisk (*) is used for female screws of soft material such as cast iron.



SPECIAL PARTS FIXING NUTS AND BOLTS

Cylinder Head Cover, Cylinder Head, and Rocker Arm Shaft Bracket

kgf·m(lb.ft./N·m)

0.8 - 1.8
(5.8 - 13.0/7.8 - 17.6)

1.0 - 2.0
(7.2 - 14.4/9.8 - 19.6)

5.0 - 6.0
(36.2 - 43.4/49.0 - 58.8)

	1st Step	2nd Step
New bolt	3.0 - 5.0 (21.7 - 36.1/29.4 - 49.0)	8.2 - 9.2 (59.4 - 66.5/80.4 - 90.2)
Reused bolt	8.0 - 9.0 (57.9 - 65.1/78.4 - 88.2)	10.0 - 11.0 (72.4 - 79.6/98.1 - 107.9)



Crankshaft Bearing Cap, Connecting Rod Bearing Cap, Crankshaft Damper Pulley, Flywheel, and Oil Pan

kgf·m(lb.ft./N·m)

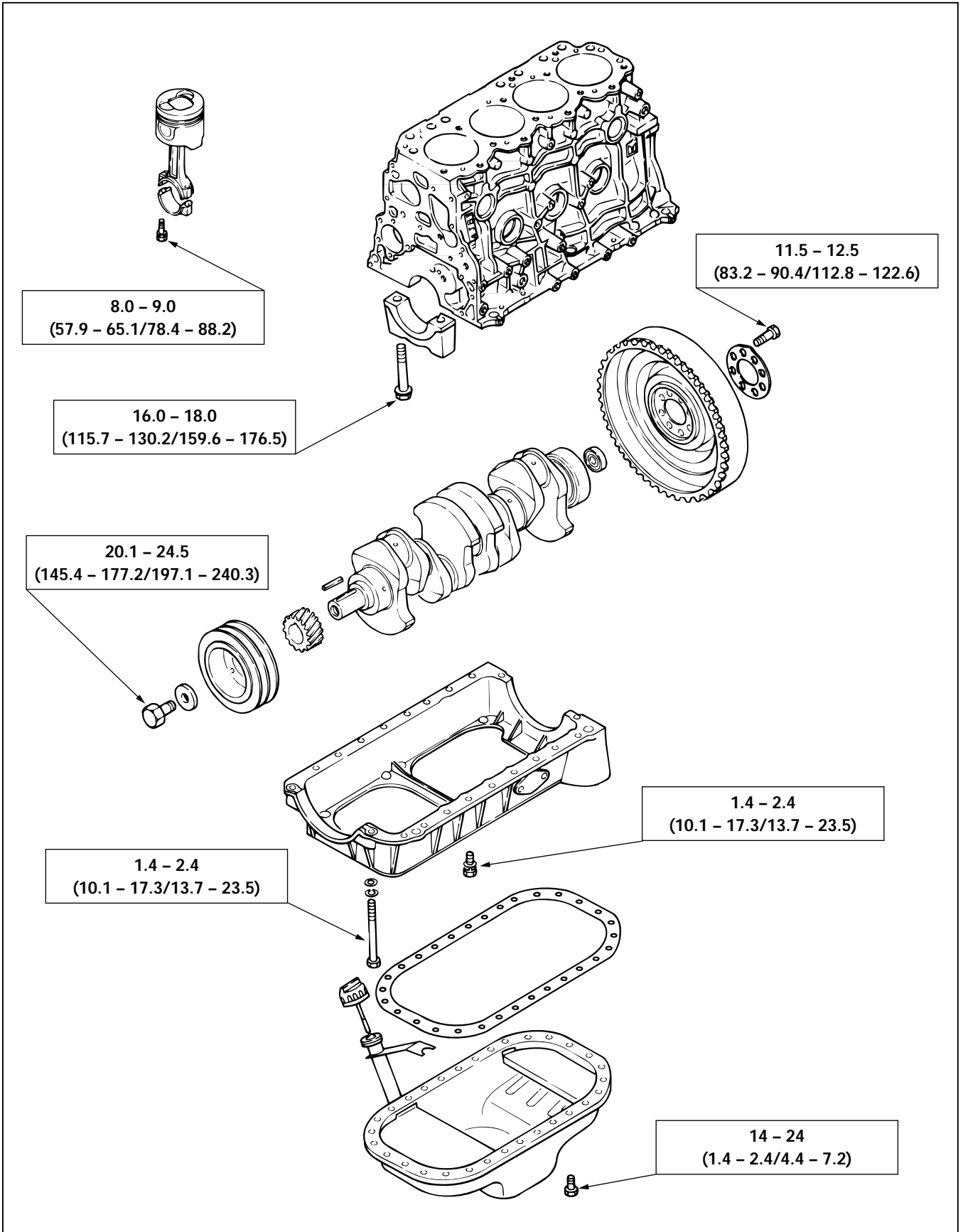



Timing Gear Case, Flywheel Housing, Camshaft, and Timing Gear

kgf·m(lb.ft./N·m)

M10 x 1.25 (0.39 x 0.05)	4.6 – 6.6 (33.3 – 47.7/45.1 – 64.7)
M12 x 1.25 (0.47 x 0.05)	9.6 – 11.6 (69.4 – 83.9/94.1 – 113.8)
M12 x 1.75 (0.47 x 0.07)	8.8 – 10.8 (63.7 – 78.1/86.3 – 105.9)

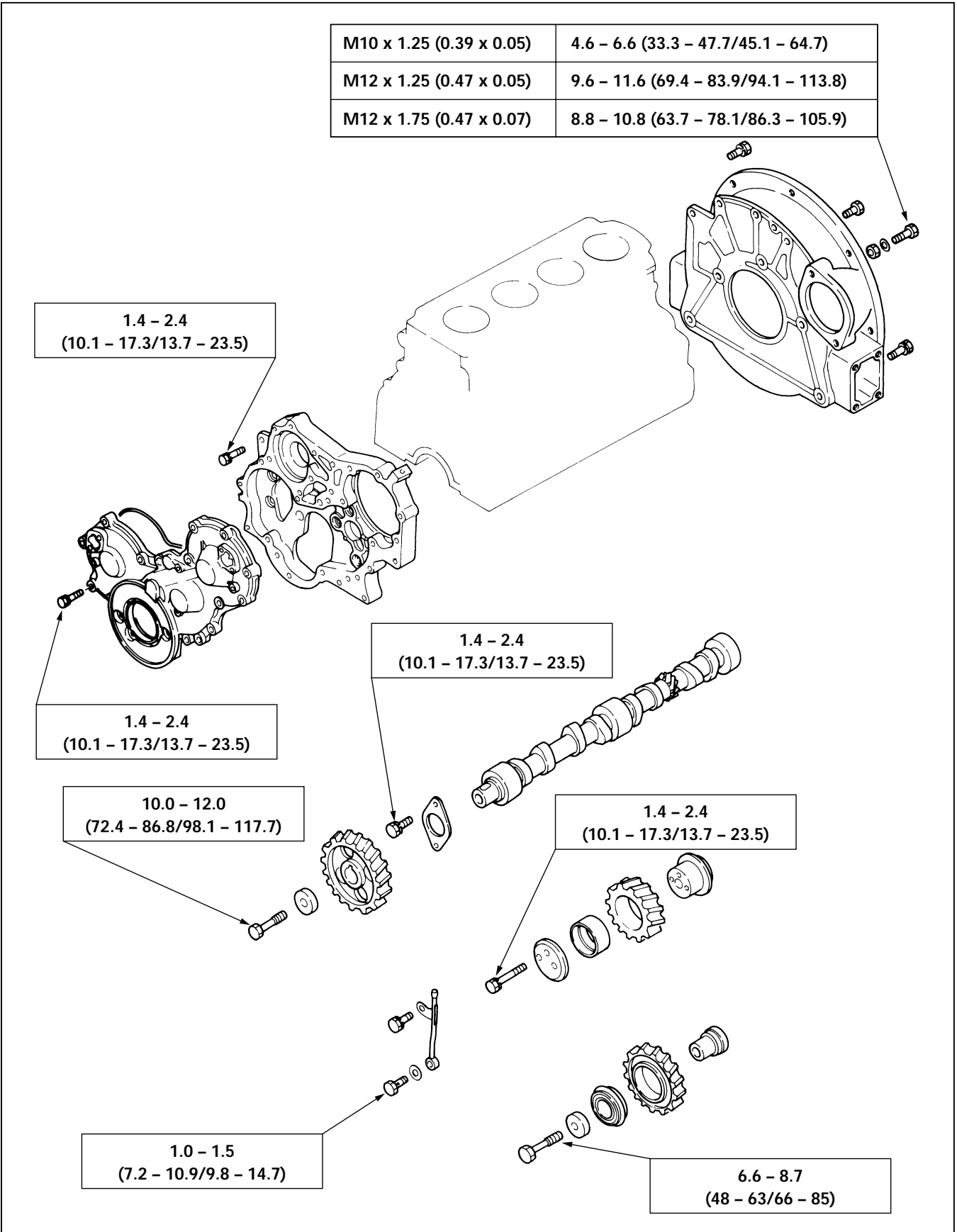



Cooling and Lubricating System

kgf·m(lb.ft./N·m)

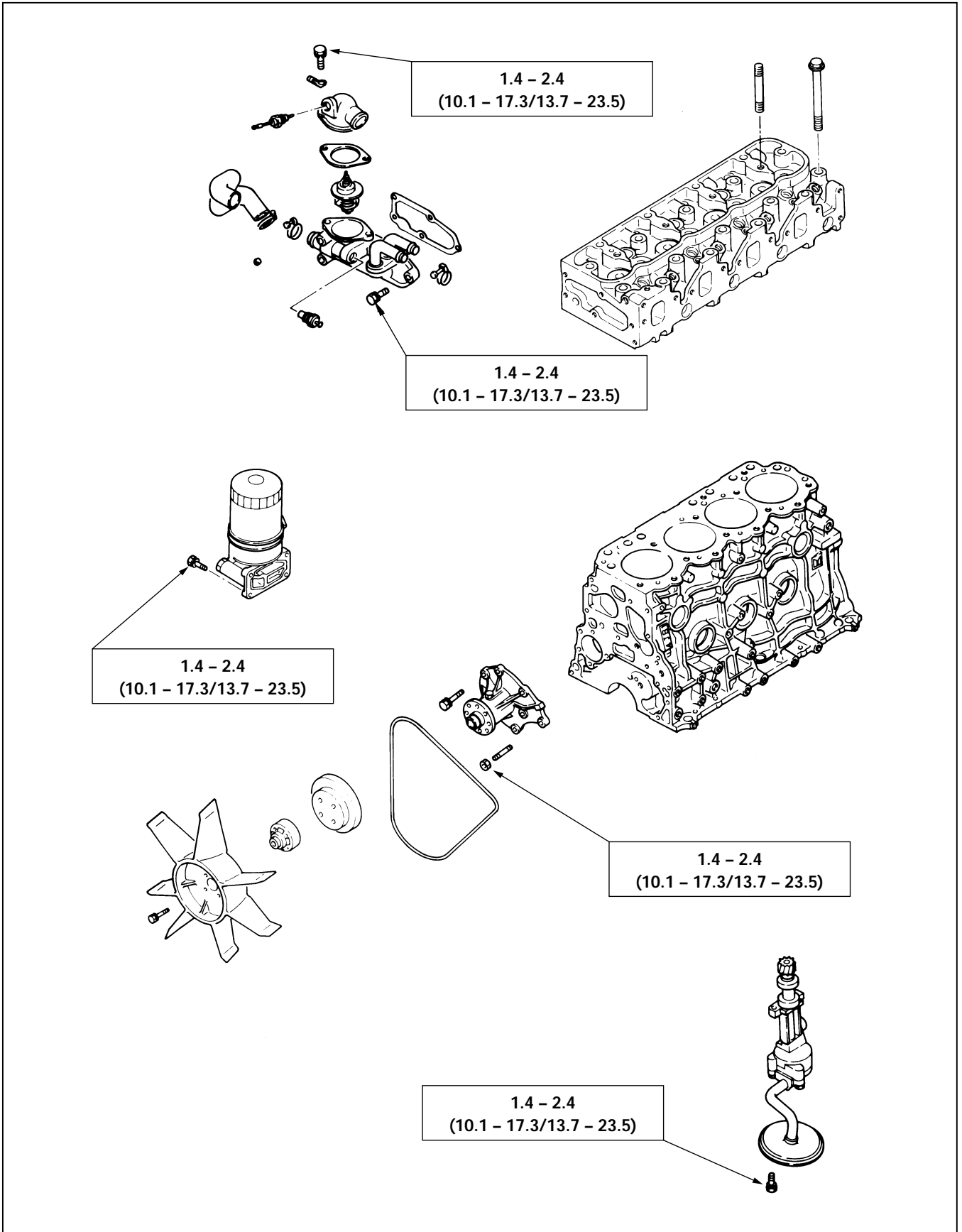



Intake and Exhaust Manifold

kgf·m(lb.ft./N·m)

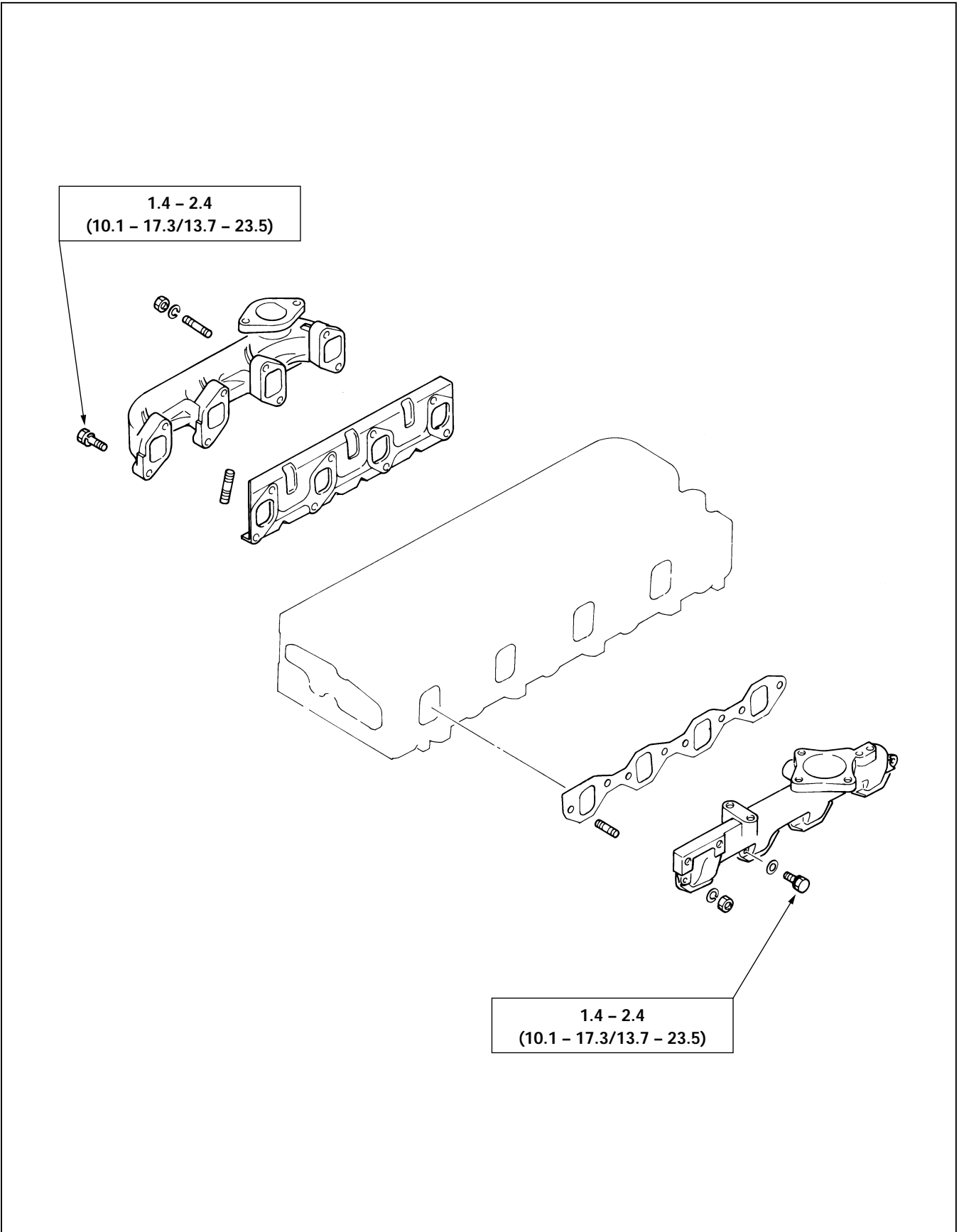



kgf·m(lb.ft./N·m)

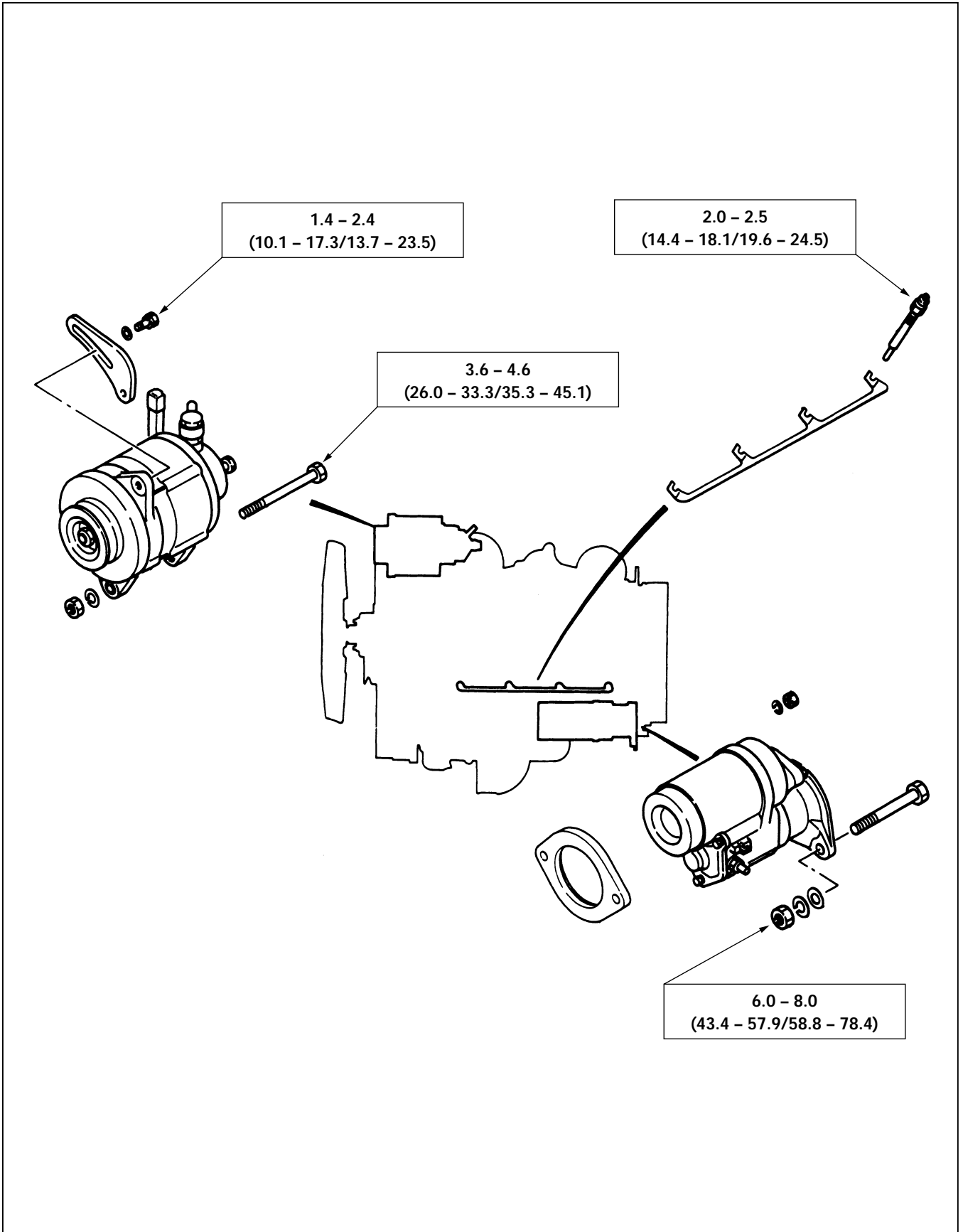



Fuel Injection System

kgf·m(lb.ft./N·m)

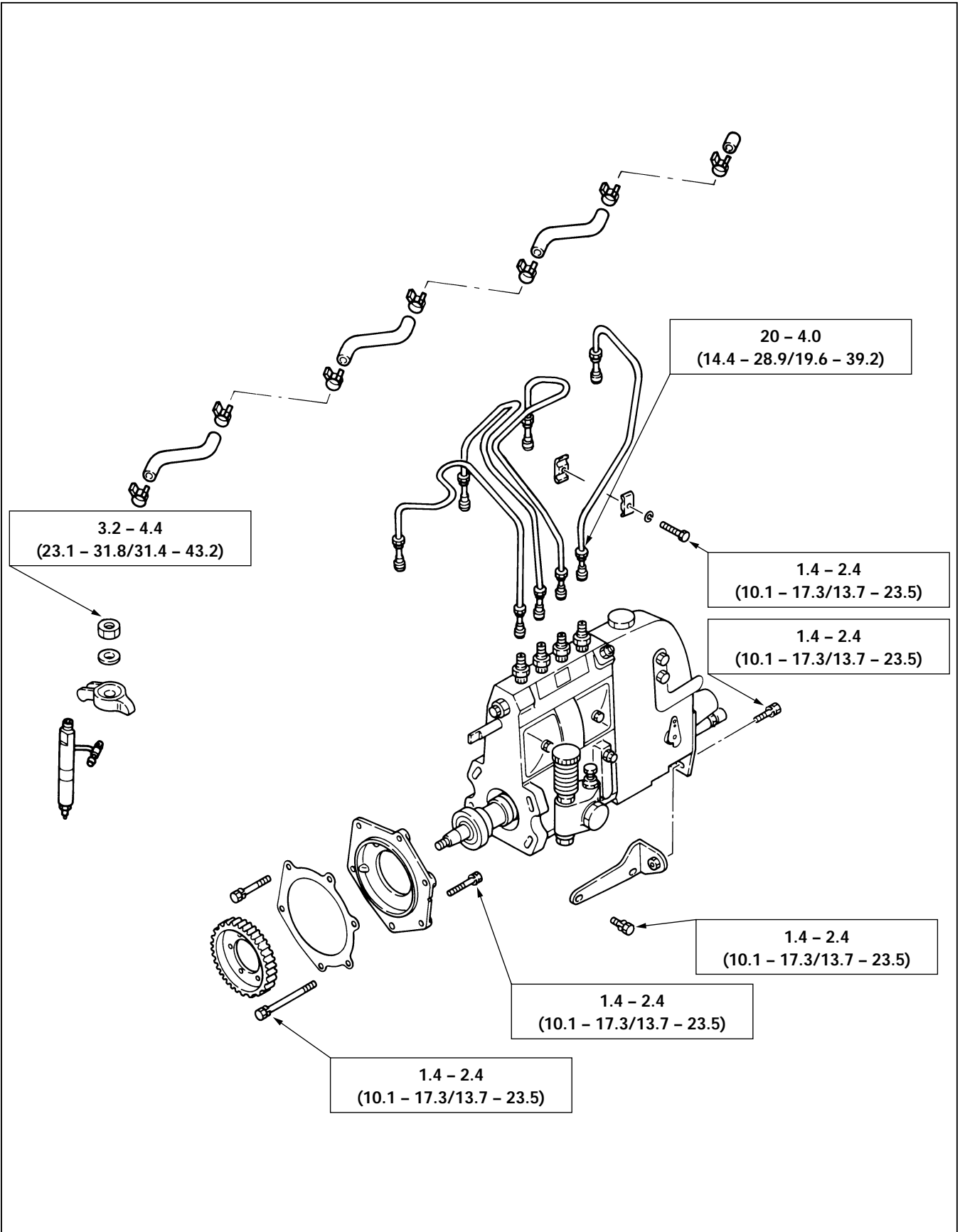

MEMO

A series of horizontal dotted lines for writing.

SECTION 2

MAINTENANCE

TABLE OF CONTENTS

ITEM	PAGE
Model identification	18
Injection pump identification	18
Lubricating system	18
Fuel system	19
Cooling system	22
Valve clearance adjustment	23
Injection timing	24
Compression pressure measurement	26
Recommended lubricants	27
Engine repair kit	28