

WORKSHOP MANUAL

**US VERSION
RIGHT HAND MODEL
EXP UBS**

ISUZU

PubNo. RV99_02-01.E

WORKSHOP MANUAL

1998/1999

UBS

2000

UBS

2002

UBS

THIS MALUAL INCLUDES THE FOLLOWING SECTIONS:

SECTION No.	CONTRNTS
0A	General Information
0B	Maintenance and Lubrication

[PAGE BACK](#)

[PAGE NEXT](#)

THIS MALUAL INCLUDES THE FOLLOWING SECTIONS:

SECTION No.	CONTRNTS
00	SERVICE INFORMATION
1A	HEATING AND VENTILATION
1B	AIR CONDITIONING
1D	COMPRESSOR OVERHAUL

[PAGE BACK](#)

[PAGE NEXT](#)

THIS MALUAL INCLUDES THE FOLLOWING SECTIONS:

SECTION No.	CONTRNTS
00	SERVICE INFORMATION
2A	FRONT END ALIGNMENT

THIS MALUAL INCLUDES THE FOLLOWING SECTIONS:

SECTION No.	CONTRNTS
3C	FRONT SUSPENSION
3D	REAR SUSPENSION; COIL SPRING
3E	WHEELS AND TIRES

THIS MALUAL INCLUDES THE FOLLOWING SECTIONS:

SECTION No.	CONTRNTS
4A1	DIFFERENTIAL (FRONT)
4A2A	DIFFERENTIAL (Rear 220mm)
4A2B	DIFFERENTIAL (REAR 244mm)
4B1	DRIVELINE CONTROL SYSTEM (SHIFT ON THE FLY)
4B2	DRIVELINE CONTROL SYSTEM (TOD)
4C	DRIVE SHAFT SYSTEM
4D1	TRANSFER CASE (STANDARD TYPE)
4D2	TRANSFER CASE (TOD)

THIS MALUAL INCLUDES THE FOLLOWING SECTIONS:

SECTION No.	CONTRNTS
5A	BRAKE CONTROL SYSTEM
5B	ANTI-LOCK BRAKE SYSTEM
5C	POWER ASSISTED BRAKE SYSTEM
5D	PARKING BRAKES

THIS MALUAL INCLUDES THE FOLLOWING SECTIONS:

6VD1 / 6VE1

SECTION No.	CONTRNTS
6A	ENGINE MECHANICAL
6B	ENGINE COOLING
6C	ENGINE FUEL
6D1	ENGINE ELECTRICAL
6D2	IGNITION SYSTEM
6D3	STARTING AND CHARGING SYSTEM
6E	ENGINE DRIVEABILITY AND EMISSIONS
6F	ENGINE EXHAUST
6G	ENGINE LUBRICATION
6H	ENGINE SPEED CONTROL SYSTEM
6J	INDUCTION

4JG2

SECTION No.	CONTRNTS
00	SERVICE INFORMATION
6A	ENGINE MECHANICAL
6A2	4JG2-NA / 4JG2-TURBO ENGINE
6B	ENGINE COOLING
6C	FUEL SYSTEM
6D	ENGINE ELECTRICAL
6E	-
6F	EXHAUST
6G	-

4JX1

SECTION No.	CONTRNTS
6A	ENGINE MECHANICAL
6B	ENGINE COOLING
6C	ENGINE FUEL
6D	ENGINE ELECTRICAL
6E	ENGINE DRIVEABILITY AND EMISSIONS
6F	ENGINE EXHAUST
6G	ENGINE LUBRICATION
6H	ENGINE SPEED CONTROL
6J	INDUCTION

THIS MALUAL INCLUDES THE FOLLOWING SECTIONS:

SECTION No.	CONTRNTS
7A	AUTOMATIC TRANSMISSION (4L30-E)
7A1	TRANSMISSION CONTROL SYSTEM (4L30-E)
7B	MANUAL TRANSMISSION (AR-5)
7B	MANUAL TRANSMISSION (MUA)
7C	CLUTCH

THIS MALUAL INCLUDES THE FOLLOWING SECTIONS:

SECTION No.	CONTRNTS
8A	LIGHTING SYSTEM
8B	WIPER / WASHER SYSTEM
8C	ENTERTAINMENT
8D	WIRING SYSTEM
8E	METER AND GAUGE
8F	BODY STRUCTURE
8G	SEATS
8H	SECURITY AND LOCKS
8I	SUN ROOF/CONVERTIBLE TOP
8J	EXTERIOR / INTERIOR TRIM

THIS MALUAL INCLUDES THE FOLLOWING SECTIONS:

SECTION No.	CONTRNTS
9A	SEAT BELT SYSTEM
9J	SUPPLEMENTAL RESTRAINT SYSTEM (SRS)
9J1	RESTRAINT CONTROL SYSTEM

PAGE BACK

THIS MALUAL INCLUDES THE FOLLOWING SECTIONS:

SECTION No.	CONTRNTS
10A	CRUISE CONTROL SYSTEM

SECTION 0A

GENERAL INFORMATION

CONTENTS

	PAGE
General Repair Instructions	0A- 2
How To Use This Manual	0A- 3
Identification	0A- 6
Lifting Instructions	0A- 8
Torque Specifications	0A-10
Recommended Liquid Gasket	0A-11
Recommended Thread Locking Agents	0A-11
Abbreviations Charts	0A-12

Service Precaution

WARNING: THIS VEHICLE HAS A SUPPLEMENTAL RESTRAINT SYSTEM (SRS). REFER TO THE SRS COMPONENT AND WIRING LOCATION VIEW IN ORDER TO DETERMINE WHETHER YOU ARE PERFORMING SERVICE ON OR NEAR THE SRS COMPONENTS OR THE SRS WIRING. WHEN YOU ARE PERFORMING SERVICE ON OR NEAR THE SRS COMPONENTS OR THE SRS WIRING, REFER TO THE SRS SERVICE INFORMATION. FAILURE TO FOLLOW WARNINGS COULD RESULT IN POSSIBLE AIR BAG DEPLOYMENT, PERSONAL INJURY, OR OTHERWISE UNNEEDED SRS SYSTEM REPAIRS.

CAUTION: Always use the correct fastener in the proper location. When you replace a fastener, use ONLY the exact part number for that application. ISUZU will call out those fasteners that require a replacement after removal. ISUZU will also call out the fasteners that require thread lockers or thread sealant. UNLESS OTHERWISE SPECIFIED, do not use supplemental coatings (Paints, greases, or other corrosion inhibitors) on threaded fasteners or fasteners joint interfaces. Generally, such coatings adversely affect the fastener torque and the joint clamping force, and may damage the fastener. When you install fasteners, use the correct tightening sequence and specification. Following these instructions can help you avoid damage to parts and systems.

GENERAL REPAIR INSTRUCTIONS

1. Park the vehicle on level ground and chock the front or rear wheels before lifting the vehicle.
2. Use covers on the vehicle body, seats, and floor to prevent damage and/or contaminations.
3. Disconnect the grounding cable from the battery before performing service operations. This will prevent cable damage or burning due to shortcircuiting.
4. Raise the vehicle with a jack set against the recommended lifting points (see "Lifting instructions" in this section).
5. Support the vehicle on chassis stands.
6. Handle brake fluid and antifreeze solution with great care.
Spilling these liquids on painted surfaces will damage the paint.
7. The use of the proper tool(s) and special tool(s) where specified is essential to efficient, reliable, and safe service operations.
8. Always use genuine ISUZU replacement parts.
9. Discard used cotter pins, gasket, plastic clips, O-rings, oil seals, lock washers, and self-locking nuts at disassembly.
Normal function of these parts cannot be guaranteed if they are reused.
10. Keep the disassembled parts neatly in groups. This will facilitate smooth and correct reassembly.
11. Keep fixing nuts and bolts separate.
Fixing nuts and bolts vary in hardness and design according to installation positions.
12. Clean all parts before inspection or reassembly.
13. Clean the oil ports and other openings with compressed air to make certain that they are free of dirt and obstructions.
14. Lubricate the rotating and sliding faces of all moving parts with oil or grease before installation.
15. Use the recommended liquid gasket to prevent leakage.
16. Carefully observe all nut and bolt torque specifications.
17. When service operation is completed, make a final check to be sure service has been done properly and problem has been corrected.
18. When removing or replacing parts that require refrigerant to be discharged from the air conditioning system, be sure to use the following tools to recover and recycle the Refrigerant-134a (R-134a).
For 134a:
Use the R-134a Refrigerant Recovery/Recovery/Recycling/Recharging/System (ACR⁴) or its equivalent to prevent the discharge of refrigerant into the air.

HOW TO USE THIS MANUAL

1. Find the applicable section by referring to the table of contents on the introduction page of each manual.
2. In "Service Information", an opening section of each manual, the troubleshooting, maintenance servicing, service data and/or information on special tools required for the service operations described in the next subsequent sections are arranged and compiled so concisely that you can see at a first glance.
3. Each section except the Service Information section is basically arranged in the following order of headings:
 - General description
 - On-vehicle service
 - Unit repair
4. The service operations are in two groups: one is the "On-vehicle service" where operations can be directly performed on the vehicle, and the other is the "Unit repair" where the operations are done on the work bench after removing the unit from the vehicle.
5. Each service operation section begins with a disassembled view of unit or equipment, which is useful to find relative components, service procedure, availability and contents of repair kits, etc.

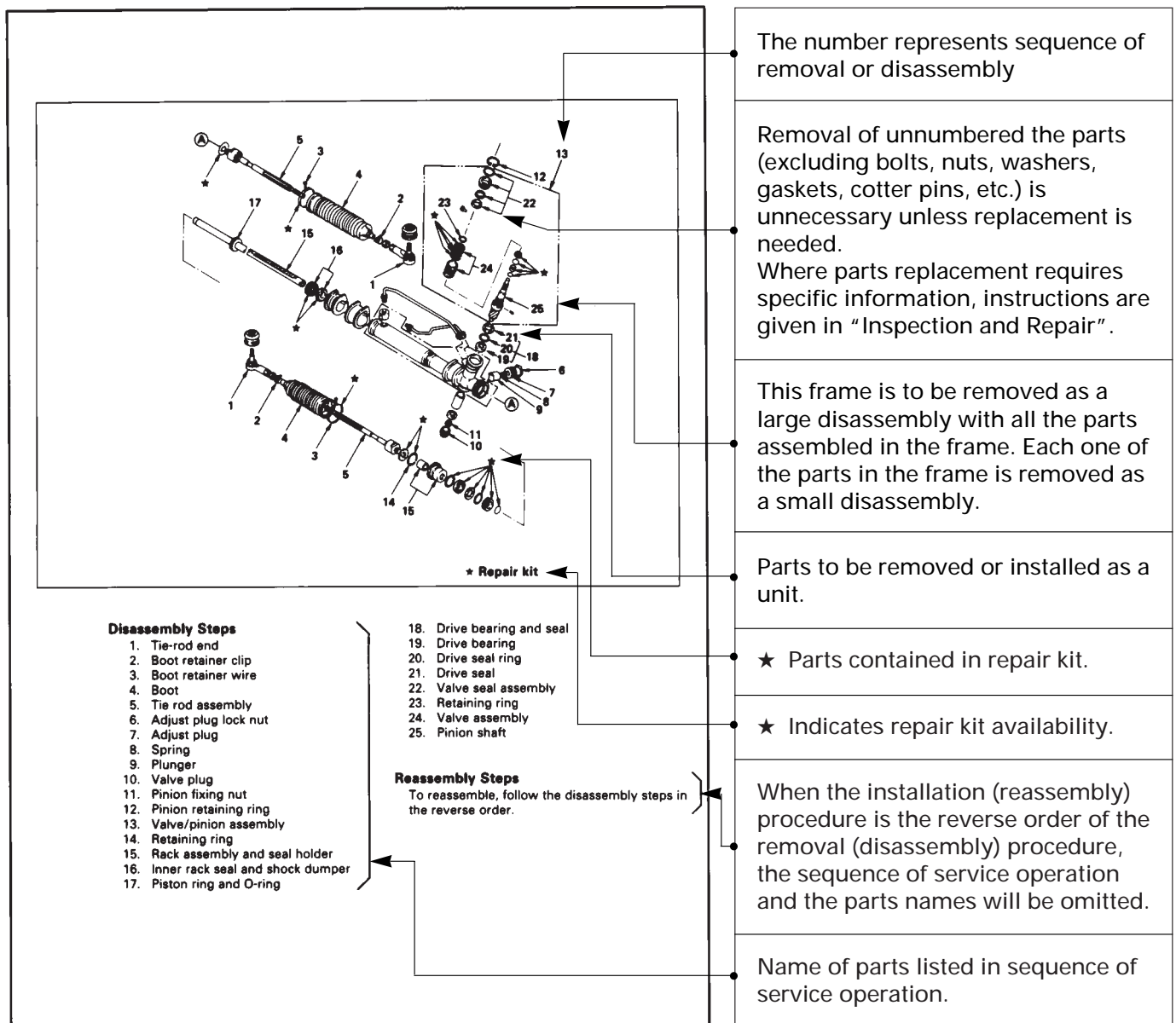

0A-4 GENERAL INFORMATION

For illustrations where there are few items to be performed:

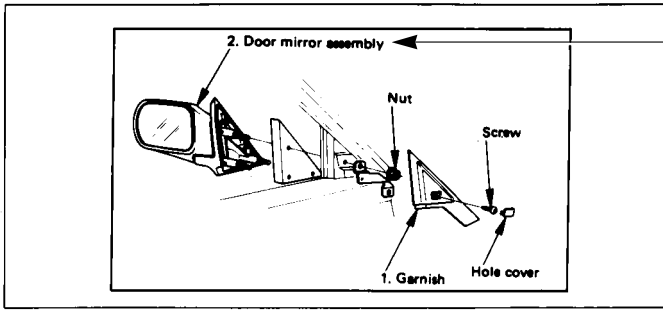

The sequence of removal (disassembly) and the parts names will be given.

6. After the illustration, the details of each operation are shown in the order the operations are carried out in the illustration. Refer to the explanations when checking important

information such as the notes in each operation, and places where special tools are to be used and their usage, and the specified service data.

REASSEMBLY

25. Pinion Shaft
 Pinion seal installer: 5-8840-0602-0 (J-38304-9)
 Slide oil seal onto shaft.

6. Adjust Plug Lock Nut
 Adjust plug lock nut wrench: 5-8840-0232-0 (J-35309)

- 1) Tighten the adjust plug to 5 N·m (0.5 kg·m / 43 lb·in), loosen the plug and once again tighten plug to 5 N·m (0.5 kg·m / 43 lb·in).
- 2) Back off plug 26° then tighten the lock nut.
- 3) Check the pinion shaft preload.

Pinion Shaft Preload	N·m (kg·cm / lb·in)
	0.6 - 1.6 (6 - 16 / 5.3 - 14.1)

Torque should be between 0.6-1.6 N·m (6-16 kg·cm / 5.3-14.1 lb·in)
 NOTE: Due to tolerances, some sockets will require wrapping shim stock around the stub shaft serrations to make a tight enough fit.

The symbol mark attached to the title indicates the action to be taken in the operations of each title. Example for this case; 1st step - Reassemble pinion shaft

The numbers given to the installation (assembly) procedure are the same as those given in the removal (disassembly) procedure in the illustration. Therefore, start with the larger number during reassembly.

The titles of operations done in the illustration are given in bold letters. They are described in the order of the procedure of the operations.

Special tools are identified with tool name and/or tool number. The drawing illustrates how the tool is used.

Service data and specifications are listed in table.

Important note.

The action symbol indicates the step of service to be followed. Refer to the following paragraph for the meaning of each symbol.

7. In this manual, the following action symbols are used to indicate the type of service operations to be performed.

 ... Remove or disconnect

 ... Install or connect

 ... Disassemble

 ... Reassemble

 ... Align the marks

 ... Correct direction

 ... Inspect

 ... Take measurement

 ... Adjust

 ... Clean

 ... Pay close attention - Important

 ... Tighten to specified torque

 ... Use special tool(s)

 ... Lubricate with oil

 ... Lubricate with grease

 ... Use liquid gasket

8. The service standard is indicated in terms of "Standard" and "Limit".
The "Standard" means the assembly standard and standard range within which the parts are

considered serviceable.
"Limit" indicates the limit value (Correction or replacement is necessary when measurement is beyond this limit.)

0A-6 GENERAL INFORMATION

IDENTIFICATION

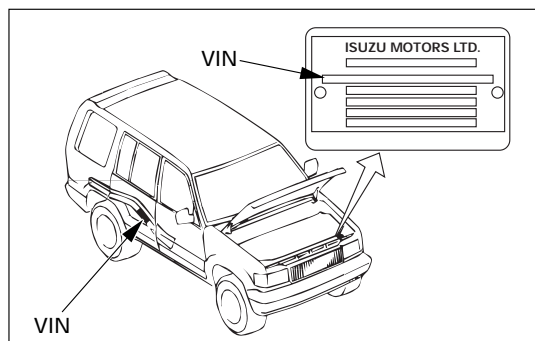

VEHICLE IDENTIFICATION NUMBER (VIN)

This is the legal identification of the vehicle. It appears on the manufacturer's Plate attached to the left of the engine compartment front end. VIN number is also stamped on the rear right side of the frame.

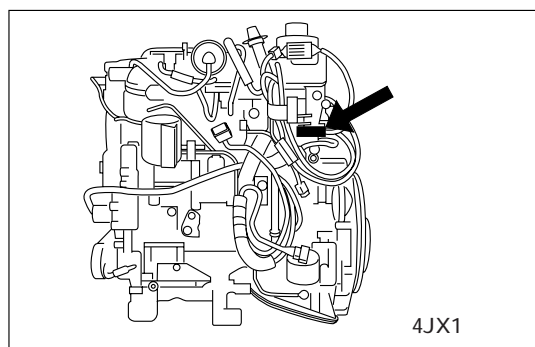
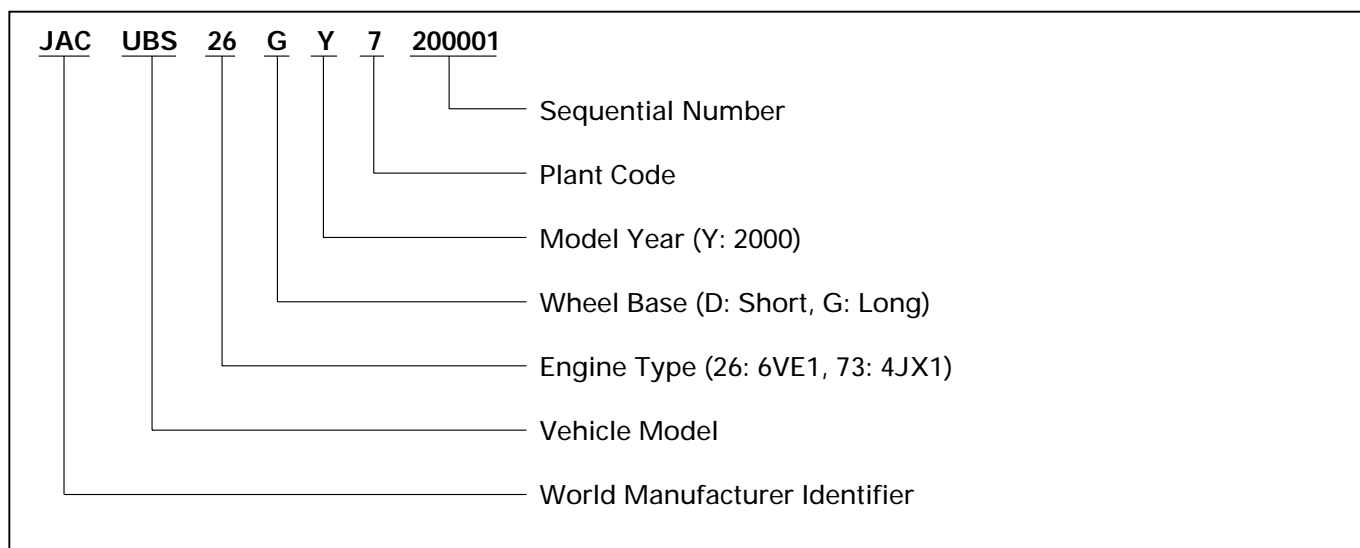

ENGINE SERIAL NUMBER

The engine serial number is stamped on the left rear lower area of the cylinder block above the starter.

