

INDUSTRIAL DIESEL ENGINE

3LA1, 3LB1, 3LD1
MODELS

INDUSTRIAL DIESEL ENGINE

3LA1, 3LB1, 3LD1
MODELS

WORKSHOP MANUAL

ISUZU MOTORS LIMITED

WORKSHOP MANUAL

ISUZU MOTORS LIMITED

FOREWORD

This Workshop Manual is designed to help you perform necessary maintenance, service, and repair procedures on applicable Isuzu industrial engines.

Information contained in this Workshop Manual is the latest available at the time of publication.

Isuzu reserves the right to make changes at any time without prior notice.

TABLE OF CONTENTS

SECTION 1.	GENERAL INFORMATION.....	1
SECTION 2.	ENGINE.....	27
SECTION 3.	LUBRICATING SYSTEM.....	83
SECTION 4.	COOLING SYSTEM.....	87
SECTION 5.	FUEL SYSTEM.....	93
SECTION 6.	TROUBLESHOOTING.....	105
SECTION 7.	SPECIAL TOOL.....	111
SECTION 8.	CONVERSION TABLE.....	113

SECTION 1

GENERAL INFORMATION

TABLE OF CONTENTS

CONTENTS	PAGE
GENERAL REPAIR INSTRUCTIONS	2
NOTES ON THE FORMAT OF THIS MANUAL	2
APPEARANCE	5
MAIN DATA AND SPECIFICATIONS.....	7
TIGHTENING TORQUE SPECIFICATIONS	9
ANGULAR NUT AND BOLT TIGHTENING METHOD.....	11
TIGHTENING TORQUE ON MAJOR COMPONENTS	13
GASKET LOCATION	18
MAINTENANCE	20
RECOMMENDED LUBRICATING OIL.....	25

GENERAL REPAIR INSTRUCTIONS

1. Before performing any service operation with the engine mounted, disconnect the grounding cable from the battery.
This will reduce the chance of cable damage and burning due to short circuiting.
2. Always use the proper tool or tools for the job at hand.
Where specified, use the specially designed tool or tools.
3. Use genuine ISUZU parts referring ISUZU PARTS CATALOG for the engines.
4. Never reuse cotter pins, gaskets, O-rings, lock washers, and self locking nuts. Discard them as you remove them. Replace them with new ones.
5. Always keep disassembled parts neatly in groups. This will ensure a smooth reassembly operation.
It is especially important to keep fastening parts separate. These parts vary in hardness and design, depending on their installation position.
6. All parts should be carefully cleaned before inspection or reassembly.
Oil ports and other openings should be cleaned with compressed air to make sure that they are completely free of obstructions.
7. Rotating and sliding part surfaces should be lubricated with oil or grease before reassembly.
8. If necessary, use a sealer on gaskets to prevent leakage.
9. Nut and bolt torque specifications should be carefully followed.
10. Always release the air pressure from any machine-mounted air tank(s) before dismantling the engine or disconnecting pipes and hoses.
11. Always check and recheck your work. No service operation is complete until you have done this.
12. Information contained in the "Main Data and Specifications" of the Workshop Manual and the Instruction Book may differ. In this case, the information contained in the Instruction Book should be considered applicable.

NOTES ON THE FORMAT OF THIS MANUAL

This Workshop Manual is applicable to the 3LA1, 3LB1, 3LD1 family of industrial diesel engines. Unless otherwise specified, these engines have common parts and components as well as data and specifications.

Illustrations used in this Workshop Manual are based on the 3LB1 and 3LD1 engines.

1. Find the applicable section by referring to the Table of Contents at the beginning of the Manual.
2. Common technical data such as general maintenance items, service specifications, and tightening torques are included in the "General Information" section.
3. Each section is divided into sub-sections dealing with disassembly, inspection and repair, and reassembly.
4. When the same servicing operation is applicable to several different units, the manual will direct you to the appropriate page.
5. For the sake of brevity, self-explanatory removal and installation procedures are omitted.
More complex procedures are covered in detail.

- Each service operation section in this Workshop Manual begins with an exploded view of the applicable area.

(Example)

Major components

Figures in parentheses “()” show the order of disassembling or reassembling.

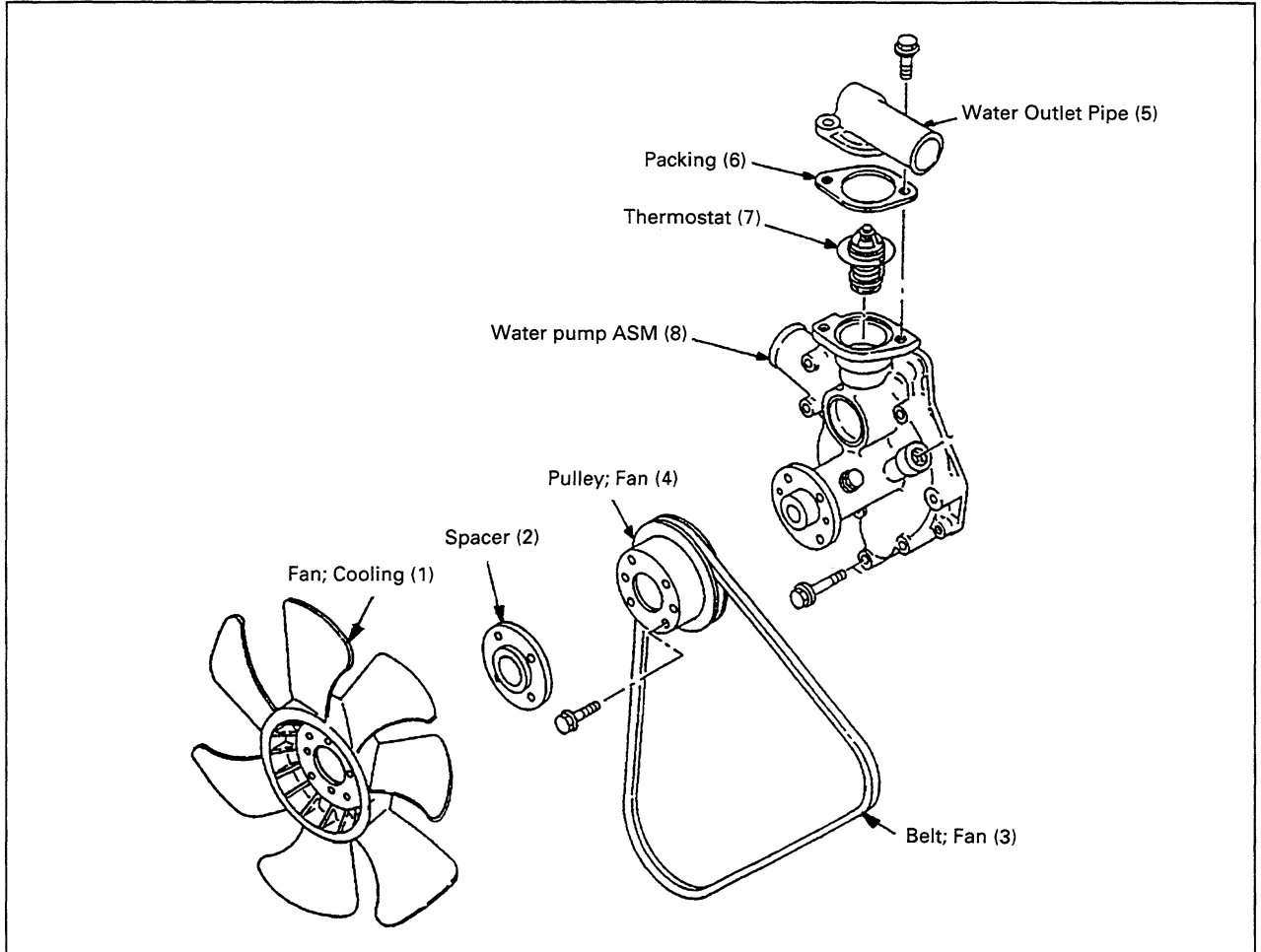

Fig. 1

- Measurement criteria are defined by the terms “standard” and “limit”.

A measurement falling within the “standard” range indicates that the applicable part or parts are serviceable.

“Limit” should be thought of as an absolute value.

A measurement which is outside the “limit” indicates that the applicable part or parts must be either repaired or replaced.

- Components and parts are listed in the singular form throughout the Manual.

4 GENERAL INFORMATION

9. The following symbols appear throughout this Workshop Manual. They tell you the type of service operation or step to perform.



... Remove



... Adjustment



... Installation



... Cleaning



... Disassembly



... Important Operation Requiring Extra Care



... Reassembly



... Specified Torque (Tighten)



... Alignment (Marks)



... Special Tool Use Required for Recommended (Isuzu Tool or Tools)



... Directional Indication



... Commercially Available Tool Use Required or Recommended



... Inspection



... Lubrication (Oil)



... Measurement



... Lubrication (Grease)



... Liquid Gasket Application

10. Direction used in this Manual are as follows:

Front

The cooling fan side of the engine viewed from the flywheel.

Right

The injection pump side of the engine.

Left

The exhaust manifold side of the engine.

Rear

The flywheel side of the engine.

Cylinder numbers are counted from the front of the engine.

The front most cylinder is No. 1 and rear most cylinder is No.

The engine's direction of rotation is counterclockwise viewed from the flywheel.

APPEARANCE

1. MODELS 3LA1 AND 3LB1

(1) Left side view

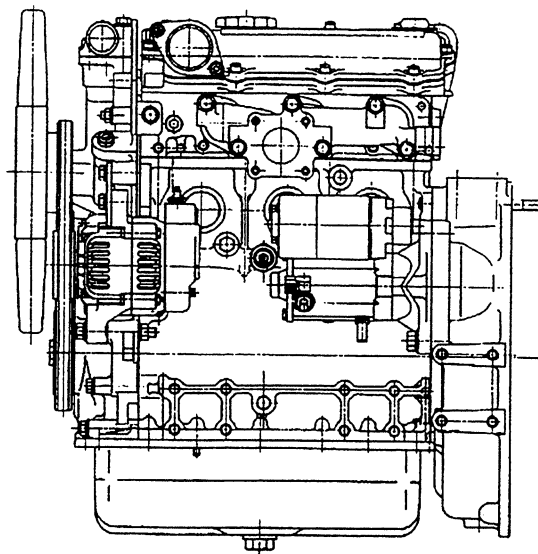

Fig. 2

(2) Right side view

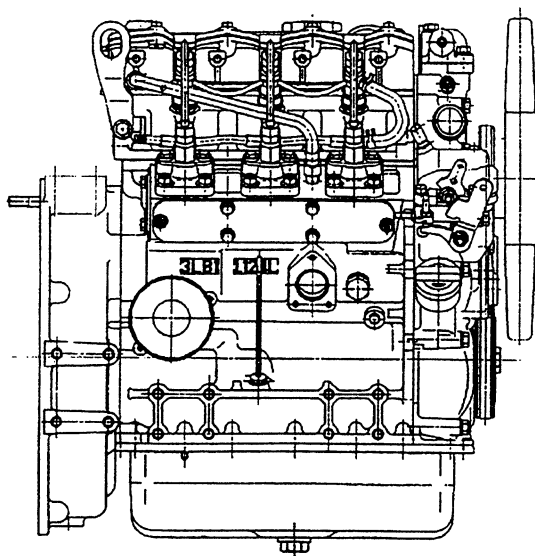

Fig. 3