

# SERVICE MANUAL

*Robex* 28-7

SER. NO. HY2870001~





# INTRODUCTION

To insure a long life for the machine and the engine and to prevent failure and problems, proper operation, maintenance and repairs are imperative.

This service manual includes an “outline,” “structure and operation,” “inspection and adjustment,” “disassembly and assembly,” “standard maintenance,” and “repair and replacement of parts” of the machine which are necessary to carry out the inspections and repairs in the repair shop.

We trust that this manual will help you to effectively carry out the necessary. Repairs should they arise, also provide a accurate description of the product, and the correct repair procedures.



# CONTENTS

1. Precautions on Maintenance
2. Outline
3. Attachment
4. Engine
5. Main Pump
6. Hydraulic Oil Filter
7. Control Valve
8. Joystick  
(Pilot Valve)
9. Pilot Valve (1)  
(Travel)
10. Pilot valve (2)  
(Swing, PTO)
11. Pilot Valve (3)  
(Dozer)
12. Slew Motor
13. Travel Motor
14. Hydraulic Cylinder
15. Swivel Joint
16. Crawler
17. Spring Case and Grease Cylinder
18. Idler
19. Sprocket
20. Track Roller
21. Carrier Roller
22. Electrical Equipment
23. Troubleshooting

# 1 PRECAUTIONS ON MAINTENANCE

## 1. Correct operation

Correct operation means to follow the correct “procedure” and “method.”

Procedure focuses on speed and accuracy of each job.

In the method, are addressed what type of facility, tools, instruments, materials, oil should be used, how and which part should be checked, adjusted or disassembled, and what matters to attend to.

## 2. Precautions on operation

### 1. Safety check

Check that stoppers and sleepers are correctly installed for the vehicle jack-up operation.

### 2. Preparation

Prepare all of the tools and inspect and adjust the instruments.

### 3. For efficiency

#### 1) Understand the state before disassembly.

What is the problem? Is disassembly absolutely necessary?

#### 2) Before disassembly

Determine whether match marks are necessary. For the electrical system, disconnect the cable from the battery terminal.

#### 3) Precautions for disassembly

In stead of checking all of the disassembled parts at once, check each part individually as it is disassembled. When removing the hydraulic unit or the hoses, mount a dust cap on the connection.

#### 4) Repair of disassembled parts

Keep the disassembled parts in order. Clearly distinguish the parts to be replaced with new parts from those to be reused. Packings, seals, rings, split pins must be replaced.

#### NOTE:

Electrical equipment, rubbers and V belts (which are easily affected by water and oil) must be handled carefully in order to prevent soiling them.

#### 5) Clean disassembled parts

Thoroughly clean the disassembled parts.

#### 6) Assembly

Perform the assembly correctly (tightening torque, application of Three Bond, screw lock, grease, use of seal tape, etc.). Also install the hose correctly.

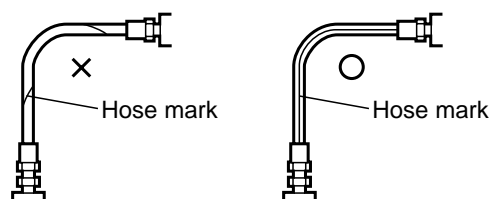

## **2** OUTLINE

### **CONTENTS**

- 2-1 Location of serial No.
- 2-2 Name of each part
- 2-3 Dimensions and specification
  - 2-3-1 H26C PTO flow
- 2-4 Weight list
- 2-5 Oil and grease supply points
- 2-6 List of supply oil and grease
- 2-7 When to repair
- 2-8 Hydraulic circuit diagram

## 2-1 Location of Serial Number

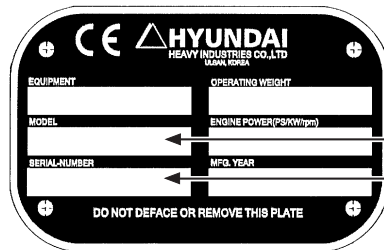
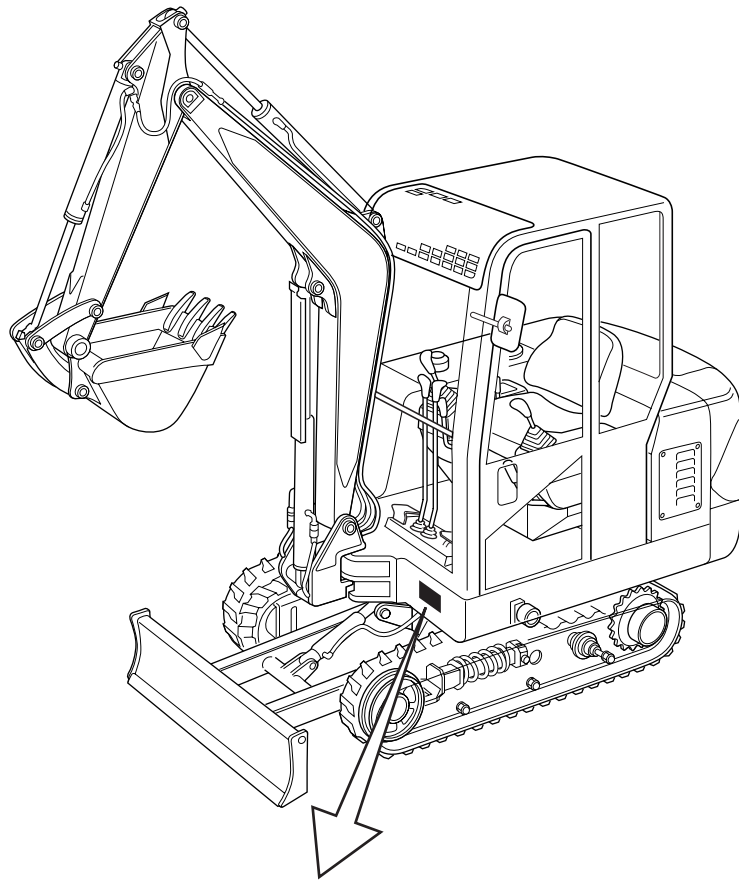

Model Name.

Serial No.



## 2-2 Name of each part

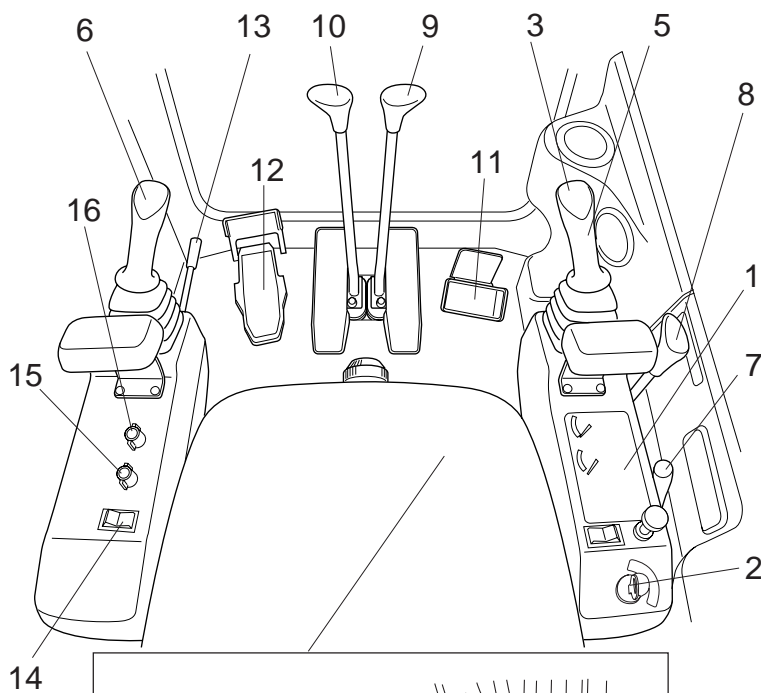

1. Meter unit
2. Starter switch
3. Horn switch
4. Fuse box
5. Right operation lever
6. Left operation lever
7. Accelerator lever
8. Dozer lever
9. Right travel lever
10. Left travel lever
11. Swing pedal
12. P.T.O. pedal
13. Operation lock lever
14. Over drive switch
15. Heater switch (for cabin)
16. Wiper switch (for cabin)
17. Manual boom lower lever
18. Cigarette lighter

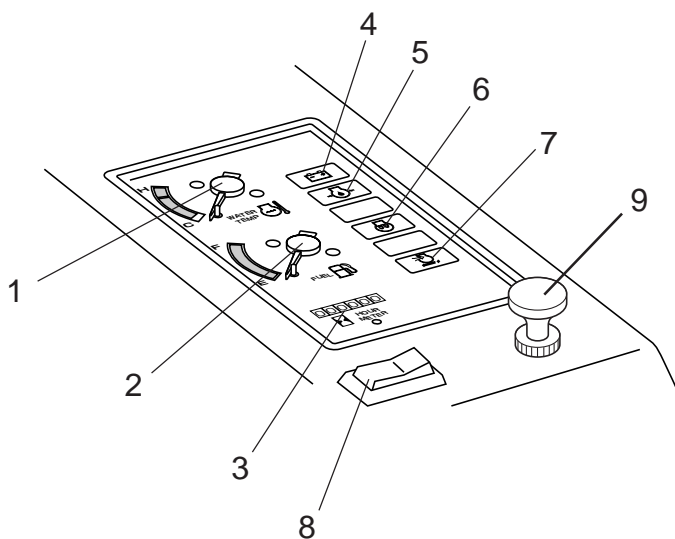
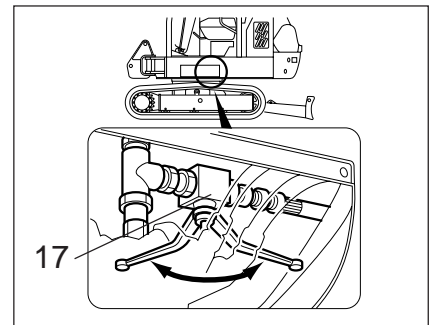
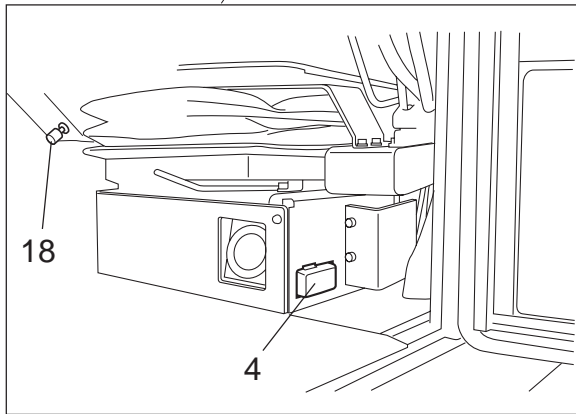

1. Water temperature meter
2. Fuel gauge
3. Hour meter
4. Charge lamp
5. Engine oil pressure lamp
6. Glow lamp
7. Air filter lamp
8. Head light switch
9. Heater change lever  
(cold↔warm)

## 2-3 Dimensions and Specifications

