

INTRODUCTION (1)

GI-1

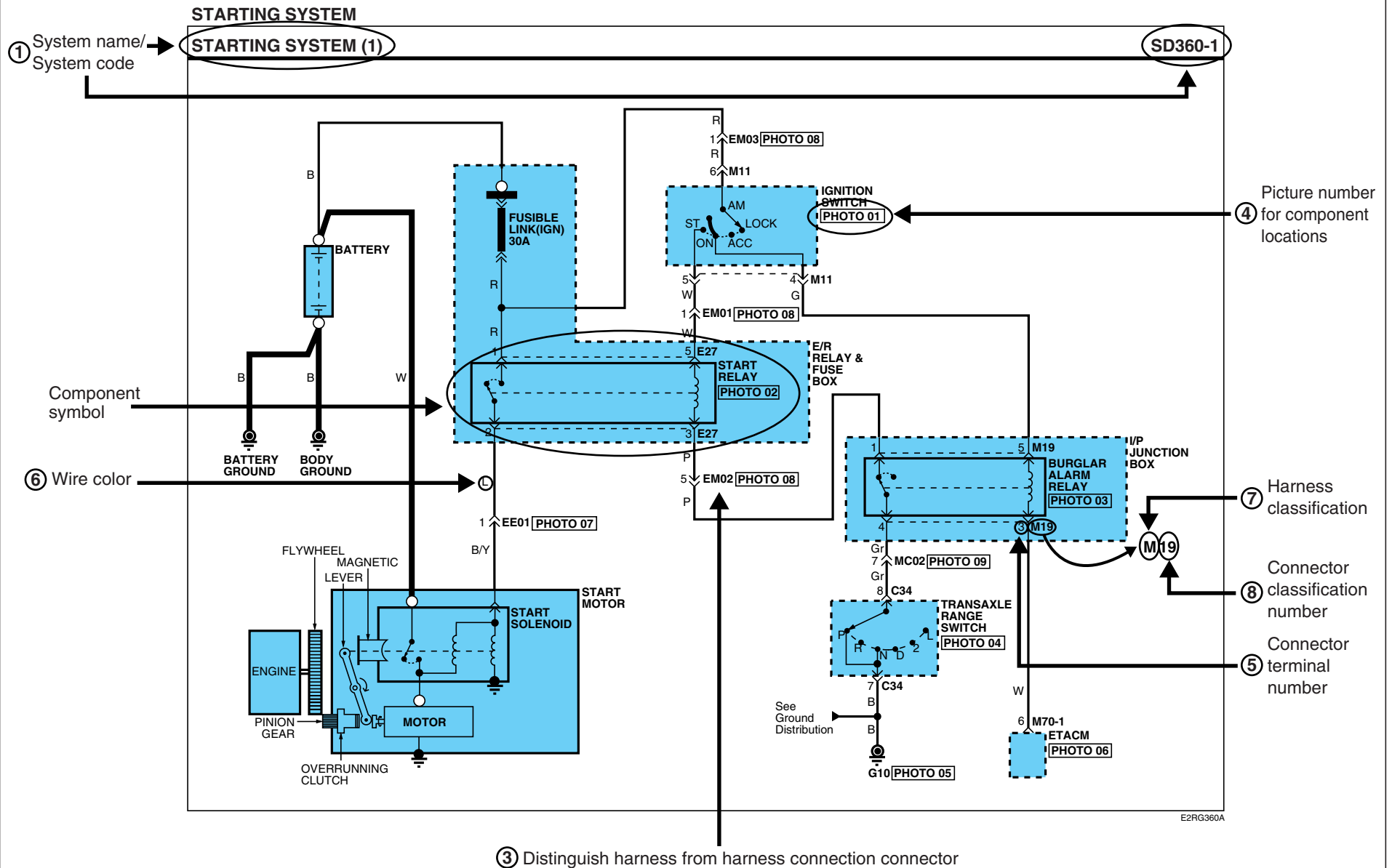

INTRODUCTION

INTRODUCTION (2)

GI-2

STARTING SYSTEM

STARTING SYSTEM (2)

SD360-2

② Connector configurations (components)

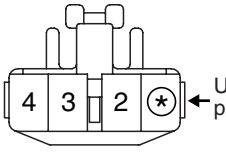
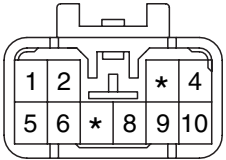
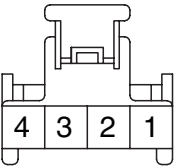
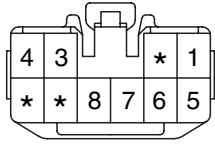
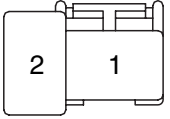
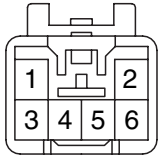
<p>M05</p>  <p>KET_090II_04F_W</p>	<p>M06</p>  <p>KET_090II_10M_W</p>	<p>M11</p>  <p>KUM_AR_04F_W</p>	<p>M13</p>  <p>KET_090II_10F_W</p>
<p>M67</p>  <p>AMP_PLM2_02F_B</p>	<p>M81</p>  <p>KET_090II_06M_W</p>	<p>BLANK</p>	<p>BLANK</p>

E2RG360B

Explanation of connector code

M05

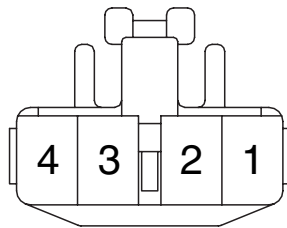

KET_090II_04F_W

a b c d e

a : Connector manufacturer

b : Terminal series number

c : The number of connector terminals

d : Connector distinguishing

- Female Pin : F
- Male Pin : M

e : Connector color abbreviations

- B (Black)
- Br (Brown)
- G (Green)
- Gr (Gray)
- L (Blue)
- R (Red)
- W (White)
- Y (Yellow)

① Pages by system/ Name of Schematic diagram

- Each page is consisted of circuits by system. This schematic diagram includes the path of electricity flow, connection condition for each switch, and the function of other relevant circuits at once. It is applicable to real service work.
- It is very important to understand relevant circuits exactly before troubleshooting diagnosis.
- Circuits by system depends upon part number and are indicated on schematic diagram index.

② Connector configuration (components)

- The connector figure of components in the schematic diagram by system is indicated on the last page of schematic diagram.
- It shows the front of the connector on the harness side when not to the harness connector. The terminal number on each connector can be obtained by following the pattern used in ⑤ connector view and numbering order. Unused terminals are marked with an asterisk (*).

③ Connector configurations (connection between harnesses)

- When connecting the harness with connector between harnesses, it shows female and male connectors and indicates them on the connector configurations group.

EM02

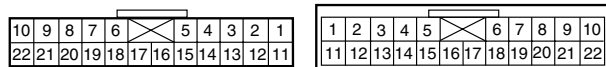

④ Component locations

- To find the components easily, a component locations diagram is indicated with "PHOTO NO" on the lower portion of the component name.
- To make it easy to distinguish connectors, the connector in the picture is indicated being installed in the vehicle.

PHOTO 03

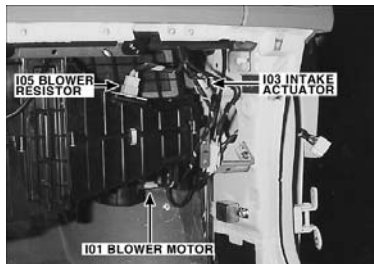

⑤ CONNECTOR VIEW AND NUMBERING ORDER

Female	Male	Remarks
		<p>It is not the shape of the connector housing, but the connector pin that distinguishes between male or female connectors. When numbering female and male connectors, refer to the numbering order in the following table. Some connectors may not follow this method of numbering order. For individual detailed numbering, refer to the CONNECTOR CONFIGURATIONS.</p>
		<p>Numbered in order from upper right to lower left</p> <p>Numbered in order from upper left to lower right</p>

NOTE

UNLESS OTHERWISE STATED, ALL CONNECTOR VIEWS ARE FROM THE TERMINAL SIDE OF THE CONNECTOR.

INTRODUCTION

INTRODUCTION (4)

GI-4

⑥ WIRE COLOR ABBREVIATIONS

The following abbreviations are used to identify wire colors in the circuit schematics.

Symbol	Color of wire	Symbol	Color of wire
B	Black	O	Orange
Br	Brown	P	Pink
G	Green	R	Red
Gr	Gray	W	White
L	Blue	Y	Yellow
Lg	Light Green	Pp	Purple
T	Tan	LI	Light Blue

* **(Y)/(B)**: Black stripe with yellow ground (2 colors)

↑ ↑
 the color of the color of
 background stripe

⑦ HARNESS CLASSIFICATION

Electrical wiring connectors are classified according to the wiring parts in the Harness Layouts.

Symbol	Harness name	Location
E	Engine harness	Engine compartment
M	Main, Floor, Floor center, Roof harness	Passenger compartment, Floor, Roof
C	Chassis, Side marker, EXH M/V harness	Chassis compartment
A	Air con, A.B.S harness	Under crash pad and Floor
D	Door harness	Door

* It depends on vehicles, it is necessary to check the harness name symbol on the harness layouts for detailed symbol.

⑧ CONNECTOR IDENTIFICATION

A connector identification symbol consists of a wiring harness location classification symbol corresponding to a wiring harness location and number corresponding to the connector. These connector locations can be found in the HARNESS LAYOUTS.

For example:

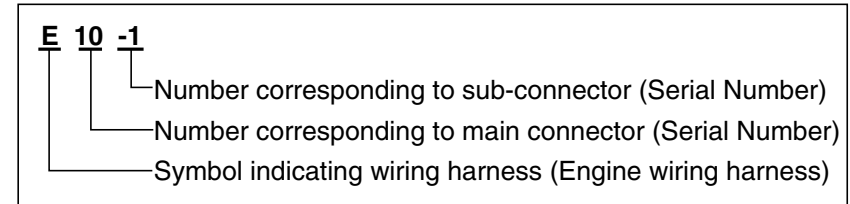

NOTE

Connectors which connect each wiring harness are represented by the following symbols.

For example:

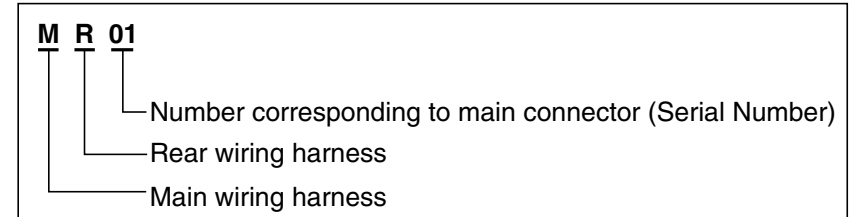

JUNCTION BLOCK IDENTIFICATION

A junction block identification symbol consists of a wiring harness location classification symbol corresponding to a wiring harness location and number corresponding to the connector in the junction block.

For example:

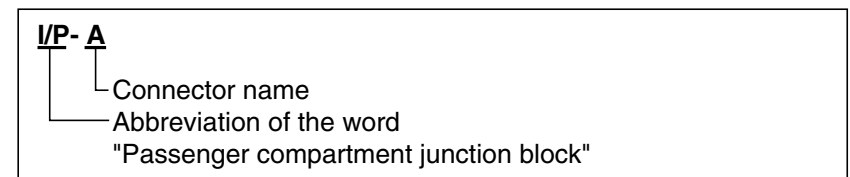

HARNESS LAYOUTS

Harness layouts show the routing of the major wiring harnesses, the in-line connectors and the splices between the major harnesses. These layouts will make electrical troubleshooting easier.

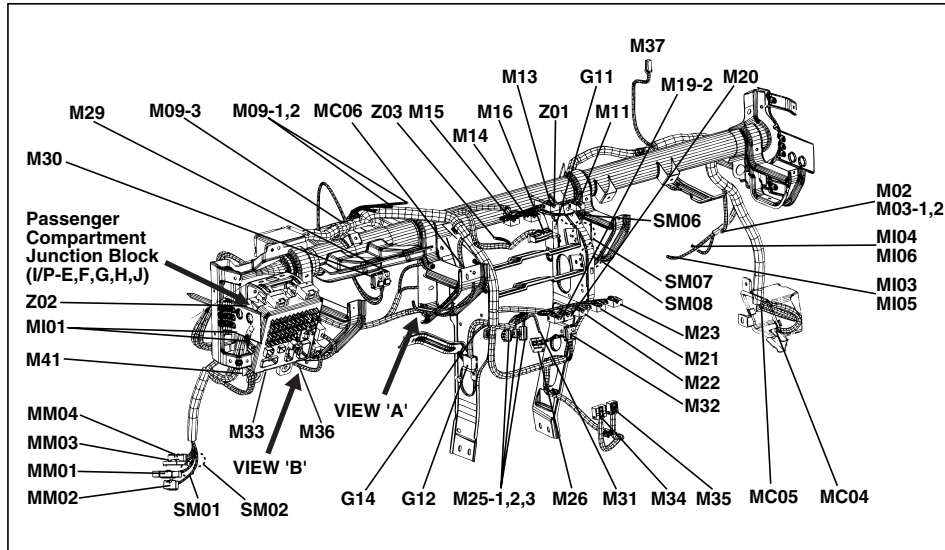









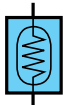
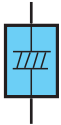

SYMBOLS (1)

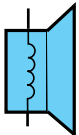
Section	Symbol	Meaning	Section	Symbol	Meaning	Section	Symbol	Meaning	Section	Symbol	Meaning
C O M P O N E N T		A solid line means the entire component is shown.	C O N N E C T O R		Shows the name of each connector on the component location index for reference. Indicates the number of corresponding terminal. (Only relevant terminal on the corresponding schematic diagram).	S H I E L D W I R E		This represents RFI (Radio Frequency Interference) Shielding around a wire. The shielding is always connected to ground.	L A M P		Double filament
		A broken line indicates only part of the component is shown.			The dashed-line means each of two wires connect with same connector(E35)			Single filament			
		This means the connector connects directly to the component.	W I R E		A wavy line means the wire is broken but is to be continued.	J O I N T C O N N E C T O R		This is a connector showing the joining wires.	D I O D E		Diode
		This indicates the connector connects to a lead (pigtail), wired directly to the component.			Wire insulation is yellow with a red strip.			Zener diode			
		This indicates the connector connects to a lead (pigtail), wired directly to the component.	I N T E R		Current path is continued on the same page or another page. The arrow shows the direction of current flow. You should look for the "A" in the marked position.	S O W B L O W		Power supplied at all times. Name Capacity	T R		NPN
		This indicates a screw terminal on the component.			A wire connects to another circuit. The wire is shown again on that circuit which the arrow is pointing.			PNP			
		This ground symbol (dot and 3 lines overlapping the component) means the housing of the component is attached to a metal part of the vehicle.	S P L I C E S		Wire choices for options or different models are labeled and shown with a "choice" bracket like this.	F U S E		This means power is supplied with the ignition on position. This means the short bar connects to other fuses. Identification Current rating	G E N E R A L C O M P O N E N T S Y M B O L		These switches move together: a dashed line shows a mechanical connection between them.
		The name of the component appears next to its upper right corner. Shows the number of pictures for component location.			Splices are numbered and shown as a dot with circle. The exact location and connection of these splices may vary among vehicles.			Control battery power at all times			Switch (1 contact point)
	The name of the component appears next to its upper right corner. Shows the number of pictures for component location.	G R O U N D		This symbol means the end of the wire is attached to a metal part of the vehicle.	C O N T R O L B A T T E R Y P O W E R		Heater				

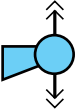
SYMBOLS

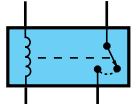
SYMBOLS (2)

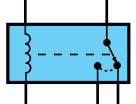
GI-7

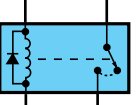
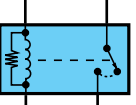
Section	Symbol	Meaning	Section	Symbol	Meaning
GENERAL COMPONENTS SYMBOL		Sensor	GENERAL COMPONENTS SYMBOL		Condenser
		Sender			Speaker
		Injector			Horn, Buzzer, Siren, Chime Bell
		Solenoid	RELAY		Normally open contact
		Motor			This is a relay shown with no current flowing through its coil. When a current flows through coil, contact will toggle.
		Battery			Diode interior relay
				Resistance interior relay	

TROUBLESHOOTING INSTRUCTIONS (1)

GI-8

TROUBLESHOOTING INSTRUCTIONS

TROUBLESHOOTING PROCEDURES

The following five-step troubleshooting procedure is recommended.

1. Verify the customer's complaints

Turn on all the components in the problem circuit to check the accuracy of the customer's complaints. Note the symptoms.

Do not begin disassembly or testing until you have narrowed down the probable causes.

2. Read and analyze the schematic diagram

Locate the schematic for the problem circuit. Determine how the circuit is supposed to work by tracing the current paths from the power source through the system components to ground. If you do not understand how the circuit should work, read the circuit operation text. Also check other circuits that share with the problem circuit. The name of circuits that share the same fuse, ground, or switch, for example, are referred to on each diagram. Try to operate any shared circuits you did not check in step 1. If the shared circuit works, the shared wiring is okay, and the cause must be within the wiring used only by the problem circuit.

If several circuits fail at the same time, the fuse or ground is a likely cause.

3. Inspect the circuit/ component with the problem isolated

Make a circuit test to check the diagnosis you made in step 2. Remember that a logical, simple procedure is the key to efficient troubleshooting. Narrow down the probable causes using the troubleshooting hints and system diagnosis charts.

Test for the most likely cause of failure first.

Try to make tests at points that are easily accessible.

4. Repair the problem

Once the problem is found, make the necessary repairs.

5. Make sure the circuit works

Repeat the system check to be sure you have repaired the problem. If the problem was a blown fuse, be sure to test all of the circuits on that fuse.

TROUBLESHOOTING EQUIPMENT

VOLTMETER AND TEST LAMP

Use a test lamp or a voltmeter on circuits without solidstate units and use a test lamp to check for voltage. A test lamp is made up of a 12-volt light bulb with a pair of leads attached. After grounding one lead, touch the other lead to various points along the circuit where voltage should be present.

When the bulb goes on, there is voltage at the point being tested.

CAUTION

A number of circuits include solid-state modules, such as the Engine Control Module(ECM), used with computer command control injection. Voltage in these circuits should be tested only with a 10-megaohm or higher impedance digital multimeter. Never use a test lamp on circuits that contain solid state modules. Damage to the modules may result.

A voltmeter can be used in place of a test lamp. While a test lamp shows whether the voltage is present or not, a voltmeter indicates how much voltage is present.

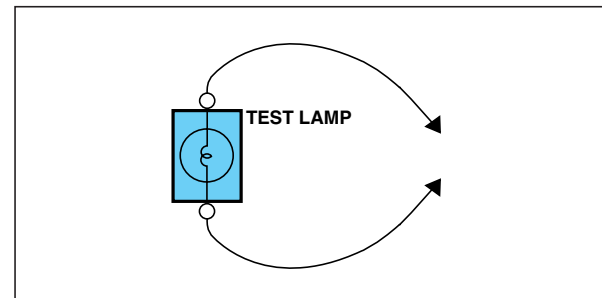
**SELF-POWERED TEST LAMP AND OHMMETER**

Use a self-powered test lamp or an ohmmeter to check for continuity.

The ohmmeter shows how much resistance there is between two points along a circuit. Low resistance means good continuity.

TROUBLESHOOTING INSTRUCTIONS

TROUBLESHOOTING INSTRUCTIONS (2)

GI-9

CAUTION

Never use a self-powered test lamp on circuits that contain solid state modules. Damage to these modules may result.

An ohmmeter can be used in place of a self-powered test lamp. The ohmmeter shows how much resistance there is between two points along a circuit. Low resistance means good continuity.

Circuits which include any solid-state devices should be tested only with a 10-megaohm or higher impedance digital multimeter. When measuring resistance with a digital multimeter, the battery negative terminal should be disconnected. Otherwise, there may be incorrect readings. Diodes and solid-state devices in a circuit can make an ohmmeter give a false reading. To find out if a component is affecting a measurement, take one reading, reverse the leads and take a second reading. If different the solid-state device is affecting the measurement.

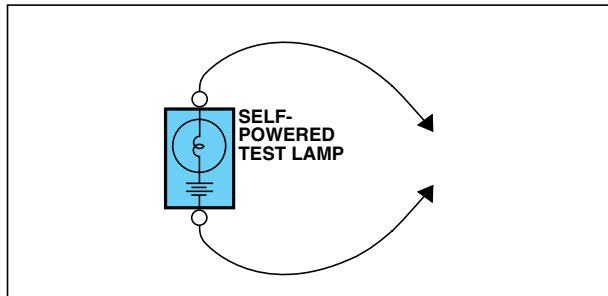

JUMPER WIRE WITH FUSE

Use a jumper wire with a fuse to by-pass an open circuit.

A jumper wire is made up of an in-line fuse holder connected to a set of test leads. This tool is available with small clamp connectors providing adaption to most connectors without damage.

CAUTION

Do not use a fuse with a higher rating than the specified fuse that protects the circuit being tested. Do not use this tool in any situation to substitute an input or output at the solid-state control module, such as ECM, TCM, etc.

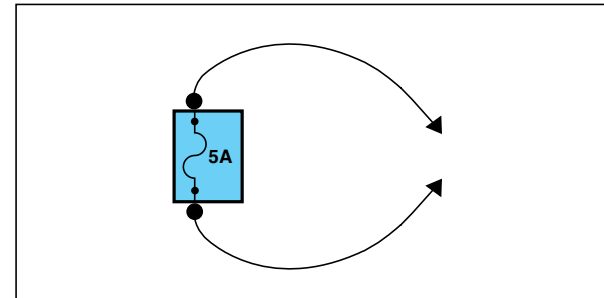

SHORT FINDER

A short finder is available to locate a short to ground. The short finder creates a pulsing magnetic field in the shorted circuit and shows you the location of the short through body trim or sheet metal.

TROUBLESHOOTING TEST

1. TESTING FOR VOLTAGE

This test measures voltage in a circuit. When testing for voltage at a connector, you do not have to separate the two halves of the connector. Instead, probe the connector from the back(backprobe). Always check both sides of the connector because dirt and corrosion between its contact surfaces can cause electrical problems.

- A. Connect one lead of a test lamp or voltmeter to a ground. If you are using a voltmeter, be sure it is the voltmeter's negative test lead you have connected to ground.
- B. Connect the other lead of the test lamp or voltmeter to a selected test point(connector or terminal).
- C. If the test lamp glows, there is voltage present. If you are using a voltmeter, note the voltage reading. A loss of more than 1 volt from specification indicates a problem.

TROUBLESHOOTING INSTRUCTIONS

TROUBLESHOOTING INSTRUCTIONS (3)

GI-10

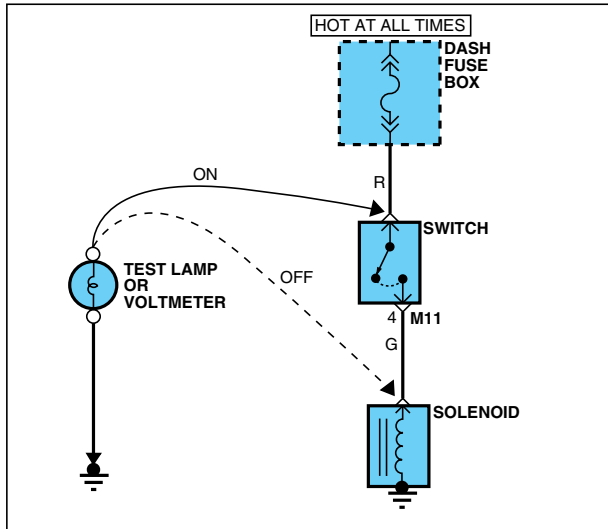

2. TESTING FOR CONTINUITY

- Disconnect the battery negative terminal.
- Connect one lead of a self-powered test lamp or ohmmeter to one end of the part of the circuit you wish to test. If you are using an ohmmeter, hold the leads together and adjust the ohmmeter to read zero ohms.
- Connect the other lead to the other end.
- If the self-power test lamp glows, there is continuity. If you are using an ohmmeter, low or zero resistance means good continuity.

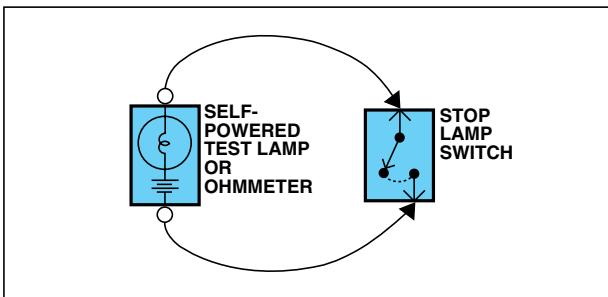

3. TESTING FOR SHORT TO GROUND

- Disconnect the battery negative terminal.
- Connect one lead of a self-powered test lamp or an ohmmeter to the fuse terminal on the load side.
- Connect the other lead to a ground.
- Beginning near the fuse block move the harness from side to side. Continue this procedure (about six inches apart) while watching the self-powered test lamp or ohmmeter.
- When the self-powered test lamp glows, or ohmmeter registers, there is a short to a ground in the wiring near that point.

