

● **FORKLIFT TRUCK**

**SERVICE
MANUAL**

**HDF15III
HDF18III**

HYUNDAI

1. STRUCTURE

This service manual has been prepared as an aid to improve the quality of repairs by giving the serviceman an accurate understanding of the product and by showing him the correct way to perform repairs and make judgements. Make sure you understand the contents of this manual and use it to full effect at every opportunity.

This service manual mainly contains the necessary technical information for operations performed in a service workshop.

For ease of understanding, the manual is divided into the following sections.

SECTION 1 GENERAL

This section gives the general information of the machine and explains the safety hints for maintenance.

SECTION 2 REMOVAL & INSTALLATION OF UNIT

This section explains the procedures and techniques of removal and installation of each component.

SECTION 3 POWER TRAIN SYSTEM

This section explains the structure of the transmission as well as control valve and drive axle.

SECTION 4 BRAKE SYSTEM

This section explains the brake piping, each component and operation.

SECTION 5 STEERING SYSTEM

This section explains the structure of the steering unit, priority valve, trail axle as well as steering circuit and operation.

SECTION 6 HYDRAULIC SYSTEM

This section explains the structure of the gear pump, main control valve as well as work equipment circuit, each component and operation.

SECTION 7 ELECTRICAL SYSTEM

This section explains the electrical circuit and each component.

It serves not only to give an understanding electrical system, but also serves as reference material for troubleshooting.

SECTION 8 MAST

This section explains the structure of mast, carriage, backrest and forks.

The specifications contained in this service manual are subject to change at any time and without any advance notice. Contact your HYUNDAI distributor for the latest information.

2. HOW TO READ THE SERVICE MANUAL

Distribution and updating

Any additions, amendments or other changes will be sent to HYUNDAI distributors.

Get the most up-to-date information before you start any work.

Filing method

1. See the page number on the bottom of the page.

File the pages in correct order.

2. Following examples shows how to read the page number.

Example 1

2 - 3

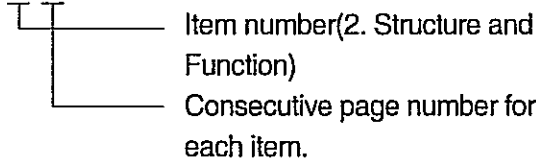

3. Additional pages : Additional pages are indicated by a hyphen(-) and number after the page number. File as in the example.

10 - 4

10 - 4 - 1

10 - 4 - 2

10 - 5

Added pages

Revised edition mark(①②③...)

When a manual is revised, an edition mark is recorded on the bottom outside corner of the pages.

Revisions

Revised pages are shown at the **list of revised pages** on the between the contents page and section 1 page.

Symbols

So that the shop manual can be of ample practical use, important places for safety and quality are marked with the following symbols.

Symbol	Item	Remarks
	Safety	Special safety precautions are necessary when performing the work.
		Extra special safety precautions are necessary when performing the work because it is under internal pressure.
	Caution	Special technical precautions or other precautions for preserving standards are necessary when performing the work.

3. CONVERSION TABLE

Method of using the Conversion Table

The Conversion Table in this section is provided to enable simple conversion of figures. For details of the method of using the Conversion Table, see the example given below.

Example

1. Method of using the Conversion Table to convert from millimeters to inches

Convert 55mm into inches.

- (1) Locate the number 50 in the vertical column at the left side, take this as (a), then draw a horizontal line from (a).
- (2) Locate the number 5 in the row across the top, take this as (b), then draw a perpendicular line down from (b).
- (3) Take the point where the two lines cross as (c). This point (c) gives the value when converting from millimeters to inches. Therefore, 55mm = 2.165 inches.

2. Convert 550mm into inches.

- (1) The number 550 does not appear in the table, so divide by 10 (Move the decimal point one place to the left) to convert it to 55mm.
- (2) Carry out the same procedure as above to convert 55mm to 2.165 inches.
- (3) The original value (550mm) was divided by 10, so multiply 2.165 inches by 10 (Move the decimal point one place to the right) to return to the original value.
This gives 550mm = 21.65 inches.

Millimeters to inches

(b)

1mm = 0.03937 in

	0	1	2	3	4	5	6	7	8	9
0		0.039	0.079	0.118	0.157	0.197	0.236	0.276	0.315	0.354
10	0.394	0.433	0.472	0.512	0.551	0.591	0.630	0.669	0.709	0.748
20	0.787	0.827	0.866	0.906	0.945	0.984	1.024	1.063	1.102	1.142
30	1.181	1.220	1.260	1.299	1.339	1.378	1.417	1.457	1.496	1.536
40	1.575	1.614	1.654	1.693	1.732	1.772	1.811	1.850	1.890	1.929
(a) 50	1.969	2.008	2.047	2.087	2.126	(c) 2.165	2.205	2.244	2.283	2.323
60	2.362	2.402	2.441	2.480	2.520	2.559	2.598	2.638	2.677	2.717
70	2.756	2.795	2.835	2.874	2.913	2.953	2.992	3.032	3.071	3.110
80	3.150	3.189	3.228	3.268	3.307	3.346	3.386	3.425	3.465	3.504
90	3.543	3.583	3.622	3.661	3.701	3.740	3.780	3.819	3.858	3.898

Millimeters to inches

1mm = 0.03937in

	0	1	2	3	4	5	6	7	8	9
0		0.039	0.079	0.118	0.157	0.197	0.236	0.276	0.315	0.354
10	0.394	0.433	0.472	0.512	0.551	0.591	0.630	0.669	0.709	0.748
20	0.787	0.827	0.866	0.906	0.945	0.984	1.024	1.063	1.102	1.142
30	1.181	1.220	1.260	1.299	1.339	1.378	1.417	1.457	1.496	1.536
40	1.575	1.614	1.654	1.693	1.732	1.772	1.811	1.850	1.890	1.929
50	1.969	2.008	2.047	2.087	2.126	2.165	2.205	2.244	2.283	2.323
60	2.362	2.402	2.441	2.480	2.520	2.559	2.598	2.638	2.677	2.717
70	2.756	2.795	2.835	2.874	2.913	2.953	2.992	3.032	3.071	3.110
80	3.150	3.189	3.228	3.268	3.307	3.346	3.386	3.425	3.465	3.504
90	3.543	3.583	3.622	3.661	3.701	3.740	3.780	3.819	3.858	3.898

Kilogram to Pound

1kg = 2.2046lb

	0	1	2	3	4	5	6	7	8	9
0		2.20	4.41	6.61	8.82	11.02	13.23	15.43	17.64	19.84
10	22.05	24.25	26.46	28.66	30.86	33.07	35.27	37.48	39.68	41.89
20	44.09	46.30	48.50	50.71	51.91	55.12	57.32	59.5	61.73	63.93
30	66.14	68.34	70.55	72.75	74.96	77.16	79.37	81.57	83.78	85.98
40	88.18	90.39	92.59	94.80	97.00	99.21	101.41	103.62	105.82	108.03
50	110.23	112.44	114.64	116.85	119.05	121.25	123.46	125.66	127.87	130.07
60	132.28	134.48	136.69	138.89	141.10	143.30	145.51	147.71	149.91	152.12
70	154.32	156.53	158.73	160.94	163.14	165.35	167.55	169.76	171.96	174.17
80	176.37	178.57	180.78	182.98	185.19	187.39	189.60	191.80	194.01	196.21
90	198.42	200.62	202.83	205.03	207.24	209.44	211.64	213.85	216.05	218.26

Liter to U.S. Gallon

1 l = 0.2642 U.S.Gal

	0	1	2	3	4	5	6	7	8	9
0		0.264	0.528	0.793	1.057	1.321	1.585	1.849	2.113	2.378
10	2.642	2.906	3.170	3.434	3.698	3.963	4.227	4.491	4.755	5.019
20	5.283	5.548	5.812	6.6076	6.340	6.604	6.869	7.133	7.397	7.661
30	7.925	8.189	8.454	8.718	8.982	9.246	9.510	9.774	10.039	10.303
40	10.567	10.831	11.095	11.359	11.624	11.888	12.152	12.416	12.680	12.944
50	13.209	13.473	13.737	14.001	14.265	14.529	14.795	15.058	15.322	15.586
60	15.850	16.115	16.379	16.643	16.907	17.171	17.435	17.700	17.964	18.228
70	18.492	18.756	19.020	19.285	19.549	19.813	20.077	20.341	20.605	20.870
80	21.134	21.398	21.662	21.926	22.190	22.455	22.719	22.983	23.247	23.511
90	23.775	24.040	24.304	24.568	24.832	25.096	25.361	25.625	25.889	26.153

Liter to U.K. Gallon

1 l = 0.21997 U.K.Gal

	0	1	2	3	4	5	6	7	8	9
0		0.220	0.440	0.660	0.880	1.100	1.320	1.540	1.760	1.980
10	2.200	2.420	2.640	2.860	3.080	3.300	3.520	3.740	3.950	4.179
20	4.399	4.619	4.839	5.059	5.279	5.499	5.719	5.939	6.159	6.379
30	6.599	6.819	7.039	7.259	7.479	7.699	7.919	8.139	8.359	8.579
40	8.799	9.019	9.239	9.459	9.679	9.899	10.119	10.339	10.559	10.778
50	10.998	11.281	11.438	11.658	11.878	12.098	12.318	12.528	12.758	12.978
60	13.198	13.418	13.638	13.858	14.078	14.298	14.518	14.738	14.958	15.178
70	15.398	15.618	15.838	16.058	16.278	16.498	16.718	16.938	17.158	17.378
80	17.598	17.818	18.037	18.257	18.477	18.697	18.917	19.137	19.357	19.577
90	19.797	20.017	20.237	20.457	20.677	20.897	21.117	21.337	21.557	21.777

kgf · m to lbf · ft

1kgf · m = 7.233lbf · ft

	0	1	2	3	4	5	6	7	8	9
		7.2	14.5	21.7	28.9	36.2	43.4	50.6	57.9	65.1
10	72.3	79.6	86.8	94.0	101.3	108.5	115.7	123.0	130.2	137.4
20	144.7	151.9	159.1	166.4	173.6	180.8	188.1	195.3	202.5	209.8
30	217.0	224.2	231.5	238.7	245.9	253.2	260.4	267.6	274.9	282.1
40	289.3	296.6	303.8	311.0	318.3	325.5	332.7	340.0	347.2	354.4
50	361.7	368.9	376.1	383.4	390.6	397.8	405.1	412.3	419.5	426.8
60	434.0	441.2	448.5	455.7	462.9	470.2	477.4	484.6	491.8	499.1
70	506.3	513.5	520.8	528.0	535.2	542.5	549.7	556.9	564.2	571.4
80	578.6	585.9	593.1	600.3	607.6	614.8	622.0	629.3	636.5	643.7
90	651.0	658.2	665.4	672.7	679.9	687.1	694.4	701.6	708.8	716.1
100	723.3	730.5	737.8	745.0	752.2	759.5	766.7	773.9	781.2	788.4
110	795.6	802.9	810.1	817.3	824.6	831.8	839.0	846.3	853.5	860.7
120	868.0	875.2	882.4	889.7	896.9	904.1	911.4	918.6	925.8	933.1
130	940.3	947.5	954.8	962.0	969.2	976.5	983.7	990.9	998.2	10005.4
140	1012.6	1019.9	1027.1	1034.3	1041.5	1048.8	1056.0	1063.2	1070.5	1077.7
150	1084.9	1092.2	1099.4	1106.6	1113.9	1121.1	1128.3	1135.6	1142.8	1150.0
160	1157.3	1164.5	1171.7	1179.0	1186.2	1193.4	1200.7	1207.9	1215.1	1222.4
170	1129.6	1236.8	1244.1	1251.3	1258.5	1265.8	1273.0	1280.1	1287.5	1294.7
180	1301.9	1309.2	1316.4	1323.6	1330.9	1338.1	1345.3	1352.6	1359.8	1367.0
190	1374.3	1381.5	1388.7	1396.0	1403.2	1410.4	1417.7	1424.9	1432.1	1439.4

kgf/cm² to lbf/in²

1 kgf/cm² = 14.2233 lbf/in²

	0	1	2	3	4	5	6	7	8	9
		14.2	28.4	42.7	56.9	71.1	85.3	99.6	113.8	128.0
10	142.2	156.5	170.7	184.9	199.1	213.4	227.6	241.8	256.0	270.2
20	284.5	298.7	312.9	327.1	341.4	355.6	369.8	384.0	398.3	412.5
30	426.7	440.9	455.1	469.4	483.6	497.8	512.0	526.3	540.5	554.7
40	568.9	583.2	597.4	611.6	625.8	640.1	654.3	668.5	682.7	696.9
50	711.2	725.4	739.6	753.8	768.1	782.3	796.5	810.7	825.0	839.2
60	853.4	867.6	881.8	896.1	910.3	924.5	938.7	953.0	967.2	981.4
70	995.6	1010	1024	1038	1053	1067	1081	1095	1109	1124
80	1138	1152	1166	1181	1195	1209	1223	1237	1252	1266
90	1280	1294	1309	1323	1337	1351	1365	1380	1394	1408
100	1422	1437	1451	1465	1479	1493	1508	1522	1536	1550
110	1565	1579	1593	1607	1621	1636	1650	1664	1678	1693
120	1707	1721	1735	1749	1764	1778	1792	1806	1821	1835
130	1849	2863	1877	1892	1906	1920	1934	1949	1963	1977
140	1991	2005	2020	2034	2048	2062	2077	2091	2105	2119
150	2134	2148	2162	2176	2190	2205	2219	2233	2247	2262
160	2276	2290	2304	2318	2333	2347	2361	2375	2389	2404
170	2418	2432	2446	2460	2475	2489	2503	2518	2532	2546
180	2560	2574	2589	5603	2617	2631	2646	2660	2674	2688
200	2845	2859	2873	2887	2901	2916	2930	2944	2958	2973
210	2987	3001	3015	3030	3044	3058	3072	3086	3101	3115
220	3129	3143	3158	3172	3186	3200	3214	3229	3243	3257
230	3271	3286	3300	3314	3328	3343	3357	3371	3385	3399
240	3414	3428	3442	3456	3470	3485	3499	3513	3527	3542

TEMPERATURE

Fahrenheit-Centigrade Conversion.

A simple way to convert a fahrenheit temperature reading into a centigrade temperature reading or vice versa is to enter the accompanying table in the center or boldface column of figures.

These figures refer to the temperature in either Fahrenheit or Centigrade degrees.

If it is desired to convert from Fahrenheit to Centigrade degrees, consider the center column as a table of Fahrenheit temperatures and read the corresponding Centigrade temperature in the column at the left.

If it is desired to convert from Centigrade to Fahrenheit degrees, consider the center column as a table of Centigrade values, and read the corresponding Fahrenheit temperature on the right.

°C		°F	°C		°F	°C		°F	°C		°F
-40.4	-40	-40.0	-11.7	11	51.8	7.8	46	114.8	27.2	81	117.8
-37.2	-35	-31.0	-11.1	12	53.6	8.3	47	116.6	27.8	82	179.6
-34.4	-30	-22.0	-10.6	13	55.4	8.9	48	118.4	28.3	83	181.4
-31.7	-25	-13.0	-10.0	14	57.2	9.4	49	120.2	28.9	84	183.2
-28.9	-20	-4.0	-9.4	15	59.0	10.0	50	122.0	29.4	85	185.0
-28.3	-19	-2.2	-8.9	16	60.8	10.6	51	123.8	30.0	86	186.8
-27.8	-18	-0.4	-8.3	17	62.6	11.1	52	125.6	30.6	87	188.6
-27.2	-17	1.4	-7.8	18	64.4	11.7	53	127.4	31.1	88	190.4
-26.7	-16	3.2	-6.7	20	68.0	12.8	55	131.0	32.2	90	194.0
-26.1	-15	5.0	-6.7	20	68.0	12.8	55	131.0	32.2	90	194.0
-25.6	-14	6.8	-6.1	21	69.8	13.3	56	132.8	32.8	91	195.8
-25.0	-13	8.6	-5.6	22	71.6	13.9	57	134.6	33.3	92	197.6
-24.4	-12	10.4	-5.0	23	73.4	14.4	58	136.4	33.9	93	199.4
-23.9	-11	12.2	-4.4	24	75.2	15.0	59	138.2	34.4	94	201.2
-23.3	-10	14.0	-3.9	25	77.0	15.6	60	140.0	35.0	95	203.0
-22.8	-9	15.8	-3.3	26	78.8	16.1	61	141.8	35.6	96	204.8
-22.2	-8	17.6	-2.8	27	80.6	16.7	62	143.6	36.1	97	206.6
-21.7	-7	19.4	-2.2	28	82.4	17.2	63	145.4	36.7	98	208.4
-21.1	-6	21.2	-1.7	29	84.2	17.8	64	147.2	37.2	99	210.2
-20.6	-5	23.0	-1.1	35	95.0	21.1	70	158.0	51.7	125	257.0
-20.0	-4	24.8	-0.6	31	87.8	18.9	66	150.8	40.6	105	221.0
-19.4	-3	26.6	0	32	89.6	19.4	67	152.6	43.3	110	230.0
-18.9	-2	28.4	0.6	33	91.4	20.0	68	154.4	46.1	115	239.0
-18.3	-1	30.2	1.1	34	93.2	20.6	69	156.2	48.9	120	248.0
-17.8	0	32.0	1.7	35	95.0	21.1	70	158.0	51.7	125	257.0
-17.2	1	33.8	2.2	36	96.8	21.7	71	159.8	54.4	130	266.0
-16.7	2	35.6	2.8	37	98.6	22.2	72	161.6	57.2	135	275.0
-16.1	3	37.4	3.3	38	100.4	22.8	73	163.4	60.0	140	284.0
-15.6	4	39.2	3.9	39	102.2	23.3	74	165.2	62.7	145	293.0
-15.0	5	41.0	4.4	40	104.0	23.9	75	167.0	65.6	150	302.0
-14.4	6	42.8	5.0	41	105.8	24.4	76	168.8	68.3	155	311.0
-13.9	7	44.6	5.6	42	107.6	25.0	77	170.6	71.1	160	320.0
-13.3	8	46.4	6.1	43	109.4	25.6	78	172.4	73.9	165	329.0
-12.8	9	48.2	6.7	44	111.2	26.1	79	174.2	76.7	170	338.0
-12.2	10	50.0	7.2	45	113.0	26.7	80	176.0	79.4	172	347.0

SECTION 1 GENERAL

Group 1 Safety Hints	1-1
Group 2 Specifications	1-5
Group 3 Periodic Replacement	1-13

SECTION 2 REMOVAL AND INSTALL OF UNIT

Group 1 Major Components	2-1
Group 2 Removal and Installation of Unit	2-2

SECTION 3 POWER TRAIN SYSTEM

Group 1 Structure and Operation	3-1
Group 2 Troubleshooting	3-15
Group 3 Tests and Adjustments	3-19
Group 4 Disassembly and Assembly	3-23

SECTION 4 BRAKE SYSTEM

Group 1 Structure and Function	4-1
Group 2 Operational Checks and Troubleshooting	4-7
Group 3 Tests and Adjustments	4-10

SECTION 5 STEERING SYSTEM

Group 1 Structure and Function	5-1
Group 2 Operational Checks and Troubleshooting	5-10
Group 3 Disassembly and Assembly	5-12

SECTION 6 HYDRAULIC SYSTEM

Group 1 Structure and Function	6-1
Group 2 Operational Checks and Troubleshooting	6-19
Group 3 Disassembly and Assembly	6-23

SECTION 7 ELECTRICAL SYSTEM

Group 1 Component Location	7-1
Group 2 Electrical Circuit	7-2
Group 3 Component Specification	7-11

SECTION 8 MAST

Group 1 Structure ----- 8-1
Group 2 Operational Checks and Troubleshooting ----- 8-4
Group 3 Adjustment ----- 8-7
Group 4 Removal and Installation ----- 8-10

SECTION 1 GENERAL

Group 1 Safety Hints	-----	1-1
Group 2 Specifications	-----	1-5
Group 3 Periodic Replacement	-----	1-13

GROUP 1 SAFETY HINTS

Careless performing of the easy work may cause injuries.

Take care to always perform work safely, at least observing the following.

- Oil is a dangerous substance. Never handle oil, grease or oily clothes in places where there is any fire or flame.
As preparation in case of fire, always know the location and directions for use of fire extinguishers and other fire fighting equipment.

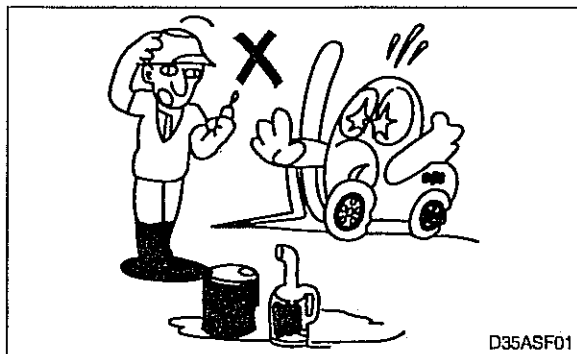

- Wear well-fitting helmet, safety shoes and working clothes. When drilling, grinding or hammering, always wear protective goggles. Always do up safety clothes properly so that they do not catch on protruding parts of machines. Do not wear oily clothes. When checking, always release battery plug.

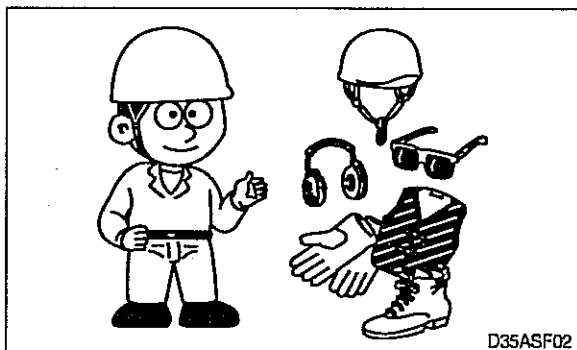

- Flames should never be used instead of lamps. Never use a naked flame to check leaks or the level of oil or electrolyte.

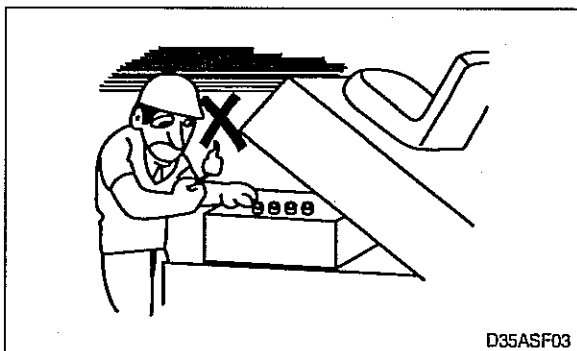

- Exhaust gas is dangerous. Provide adequate ventilation when working a closed space.

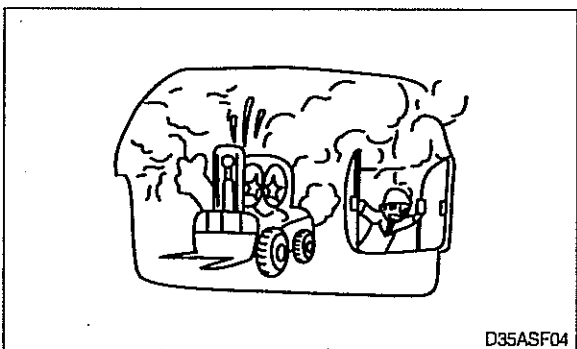

▲ Be particularly careful when removing the radiator cap and the hydraulic oil tank filler cap, if this is done immediately after using the machine, there is a danger that boiled oil may spurt out.

- The procedure for releasing the hydraulic pressure is as follows : lower the fork to the ground, and stop the engine(Motor), move the control levers to each position two or three times.

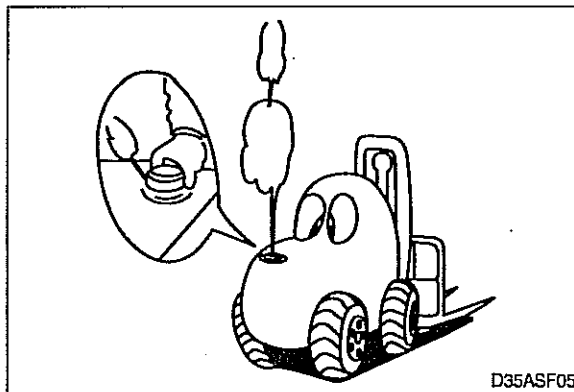

- When working on top of the machine, be careful not to lose your balance and fall.

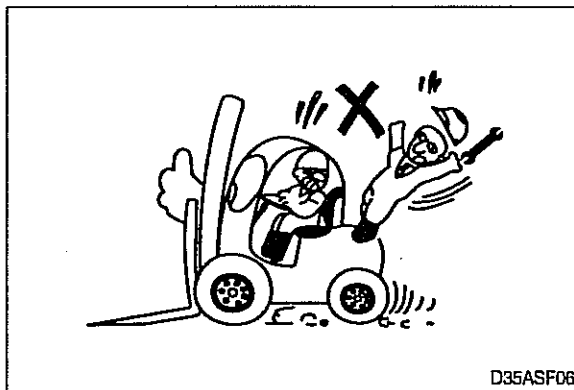

- Hand a caution sign in the operator's compartment (For example **Do not start** or **Maintenance in progress**).

This will prevent anyone from starting or moving the machine by mistake.

▲ It is extremely dangerous to try to check the fan belt tension while the engine is running.

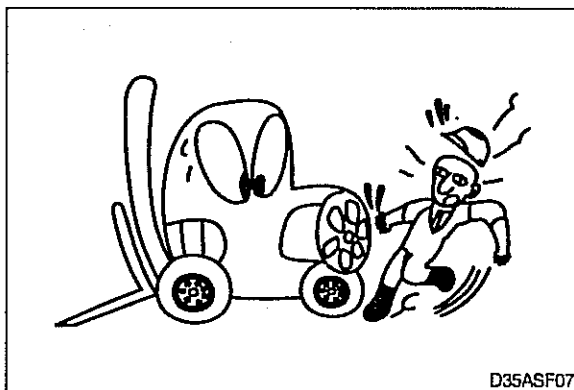

When inspecting the engine is running parts, or near such parts, always stop the engine first. Before checking or servicing accumulator or piping, depress brake pedal repeatedly to release pressure.

- Park the machine on firm, flat ground. Lower the fork to the ground and stop the engine. Return each lever to **NEUTRAL** and apply the brake lock.

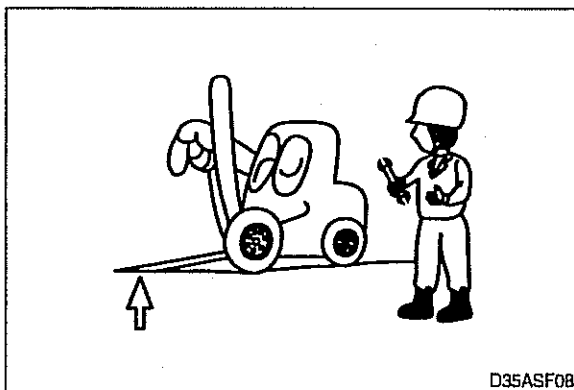

- Immediately remove any oil or grease on the floor of the operator's compartment, or on the handrail. It is very dangerous if someone slips while on the machine.

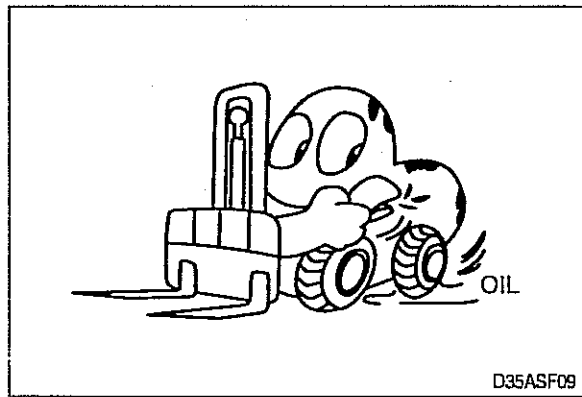

- When working with others, choose a group leader and work according to his instructions. Do not perform any maintenance beyond the agreed work.

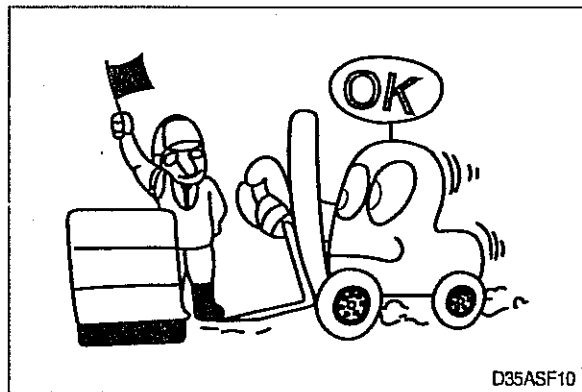

- Unless you have special instructions to the contrary, maintenance should always be carried out with the engine stopped. If maintenance is carried out with the engine running, there must be two men present : one sitting in the operator's seat and the other one performing the maintenance. In such a case, never touch any moving part.

- Always remember that the hydraulic oil circuit is under pressure. When feeding or draining the oil or carrying out inspection and maintenance, release the pressure first.

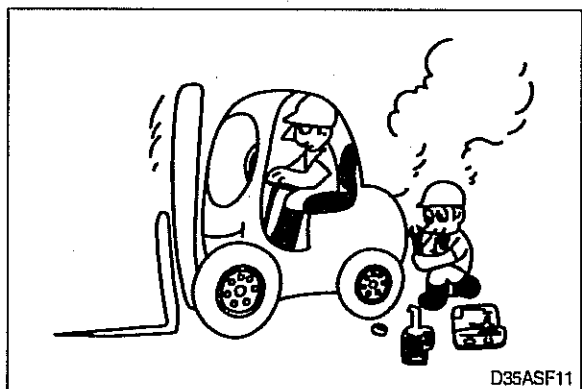

- Thoroughly clean the machine. In particular, be careful to clean the filler caps, grease fittings and the area around the dipsticks. Be careful not to let any dirt or dust into the system.
- Always use HYUNDAI Forklift genuine parts for replacement.
- Always use the grades of grease and oil recommended by HYUNDAI Forklift.
Choose the viscosity specified for the ambient temperature.
- Always use pure oil or grease, and be sure to use clean containers.
- When checking or changing the oil, do it in a place free of dust, and prevent any dirt from getting into the oil.
- Before draining the oil, warm it up to a temperature of 30 to 40° C .
- After replacing oil, filter element or strainer, bleed the air from circuit.
- When the strainer is located in the oil filler, the strainer must not be removed while adding oil.
- When changing the oil filter, check the drained oil and filter for any signs of excessive metal particles or other foreign materials.
- When removing parts containing O-ring, gaskets or seals, clean the mounting surface and replace with new sealing parts.
- After injecting grease, always wipe off the oil grease that was forced out.
- Do not handle electrical equipment while wearing wet places, as this can cause electric shock.
- During maintenance do not allow any unauthorized person to stand near the machine.
- Be sure you fully understand the contents of the operation. It is important to prepare necessary tools and parts and to keep the operating area clean.
- When checking an open gear case there is a risk of dropping things in. Before removing the covers to inspect such cases, empty everything from your pockets. Be particularly careful to remove wrenches and nuts.
- Way to use dipstick
Push the dipstick fully into the guide, and then pull out.

Carrying out other difficult maintenance work carelessly can cause unexpected accidents. If you consider the maintenance is too difficult, always request the HYUNDAI Forklift distributor to carry out it.

GROUP 2 SPECIFICATIONS

1. GENERAL LOCATIONS

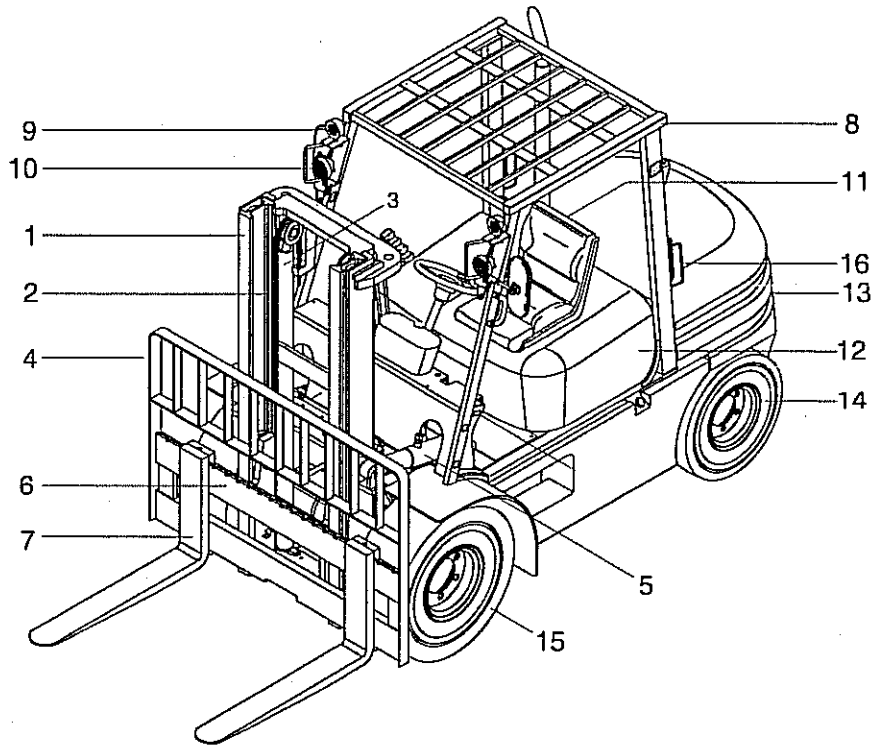

D153OM01

- | | | |
|-----------------|--------------------|--------------------------|
| 1 Mast | 7 Fork | 13 Counterweight |
| 2 Lift chain | 8 Overhead guard | 14 Rear wheel |
| 3 Lift cylinder | 9 Turn signal lamp | 15 Front wheel |
| 4 Backrest | 10 Head lamp | 16 Rear combination lamp |
| 5 Tilt cylinder | 11 Operator's seat | |
| 6 Carriage | 12 Bonnet | |

2. SPECIFICATIONS

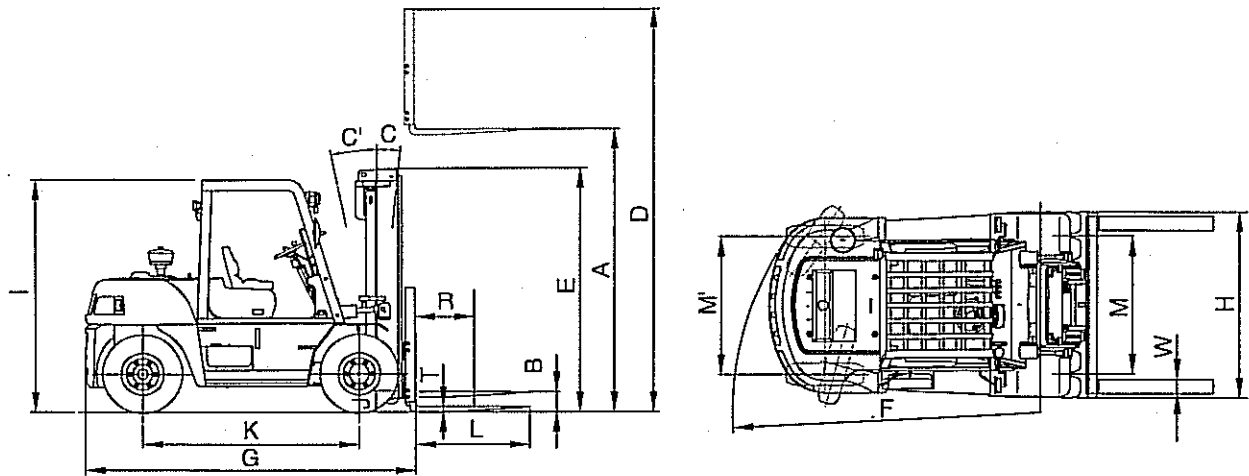

D153SP01

Model		Unit	HDF 15III	HDF 18III	
Capacity		kg	1500	1750	
Load center	R	mm	500	←	
Weight(Unloaded)		kg	2800	2980	
Fork	Lifting height	A	mm	←	
	Free lift	B	mm	←	
	Lifting speed(Unload/Load)		mm/sec	520/480	←
	Lowering speed(Unload/Load)		mm/sec	340/500	←
	L x W x T	L,W,T	mm	920 x 100 x 35	←
Mast	Tilt angle forward/backward	C/C'	degree	6/10	←
	Max height	D	mm	4320	←
	Min height	E	mm	2135	←
Body	Travel speed		km/h	20.6	←
	Gradeability		degree	15.2	13.5
	Min turning radius(Outside)	F	mm	1765	←
ETC	Max hydraulic pressure		kg/cm ²	150	←
	Hydraulic oil tank		l	36	←
	Fuel tank		l	30	←
Overall length	G	mm	2190	2220	
Overall width	H	mm	1090	←	
Overhead guard height	I	mm	2135	←	
Ground clearance	J	mm	105	←	
Wheel base	K	mm	1350	←	
Wheel tread front/rear	M, M'	mm	912/905	←	

3. SPECIFICATION FOR MAJOR COMPONENTS**1) ENGINE**

Item	Unit	Specification
Model	-	ISUZU 4LE1PW-06
Type	-	4 cycle turbocharged diesel type
Cooling Method	-	Water cooling
Number of cylinders and arrangement	-	4 cylinders, In-line
Firing order	-	1-3-4-2
Combustion chamber type	-	In-direct injection
Cylinder bore X stroke	mm(in)	85 x 96(3.35 x 3.78)
Piston displacement	cc(cu in)	2179(133)
Compression ratio	-	21.5: 1
Rated gross horse power	hp/rpm	44.5/2400
Maximum gross torque at rpm	kgf · m/rpm	13.9/1600
Engine oil quantity	l (U.S.gal)	8.1~5.6(2.1~1.5)
Dry weight	kg(lb)	180(397)
High idling speed	rpm	2640
Low idling speed	rpm	850
Rated fuel consumption	g/ps.hr	198
Starting motor	V-kW	DENSO(12-2.0)
Alternator	V-A	DENSO(12-35)
Battery	V-AH	12-100
Fan belt deflection	mm(in)	10(0.39)

2) MAIN PUMP

Item	Unit	Specification
Type	-	Fixed displacement gear pump
Capacity	cc/rev	24.5
Maximum operating pressure	bar	207
Rated speed (Max/Min)	rpm	3000/500

3) MAIN CONTROL VALVE

Item	Unit	Specification
Type	-	Sectional
Operating method	-	Mechanical
Main relief valve pressure	bar	185/150
Flow capacity	lpm	80