

# D6CA/D6CB ENGINE TROUBLESHOOTING (BUS)

## DTC

D6CA ENGINE CIRCUIT .....	FL-3	P1225 .....	FL-352
D6CB ENGINE CIRCUIT .....	FL-17	P1226 .....	FL-360
DTC LIST .....	FL-27	P1231 .....	FL-368
P0105 .....	FL-30	P1232 .....	FL-378
P0112 .....	FL-33	P1233 .....	FL-388
P0113 .....	FL-41	P1234 .....	FL-396
P0117 .....	FL-51	P1235 .....	FL-404
P0118 .....	FL-57	P1236 .....	FL-412
P0119 .....	FL-64	P1241 .....	FL-420
P0182 .....	FL-70	P1242 .....	FL-430
P0183 .....	FL-78	P1243 .....	FL-440
P0191 .....	FL-88	P1244 .....	FL-448
P0192 .....	FL-93	P1245 .....	FL-456
P0193 .....	FL-104	P1246 .....	FL-466
P0196 .....	FL-114	P1251 .....	FL-472
P0197 .....	FL-124	P1252 .....	FL-482
P0198 .....	FL-132	P1253 .....	FL-492
P0335 .....	FL-134	P1254 .....	FL-500
P0336 .....	FL-148	P1255 .....	FL-508
P0337 .....	FL-159	P1256 .....	FL-515
P0340 .....	FL-168	P1261 .....	FL-523
P0341 .....	FL-182	P1262 .....	FL-533
P0342 .....	FL-193	P1263 .....	FL-543
P0500 .....	FL-202	P1264 .....	FL-551
P0501 .....	FL-206	P1265 .....	FL-559
P0503 .....	FL-217	P1266 .....	FL-567
P0511 .....	FL-228	P1311 .....	FL-575
P0513 .....	FL-238	P1321 .....	FL-583
P1149 .....	FL-248	P1331 .....	FL-591
P1150 .....	FL-257	P1341 .....	FL-599
P1211 .....	FL-264	P1351 .....	FL-607
P1212 .....	FL-274	P1361 .....	FL-615
P1213 .....	FL-284	P1523 .....	FL-623
P1214 .....	FL-292	P1524 .....	FL-628
P1215 .....	FL-300	P1525 .....	FL-633
P1216 .....	FL-308	P1600 .....	FL-638
P1221 .....	FL-316	P1613 .....	FL-648
P1222 .....	FL-326	P1616 .....	FL-664
P1223 .....	FL-336	P1618 .....	FL-675
P1224 .....	FL-344	P1619 .....	FL-684
		P1640 .....	FL-691

P1651 ..... FL-697  
P1652 ..... FL-702  
P1653 ..... FL-708  
P1654 ..... FL-714  
P1655 ..... FL-721  
P1656 ..... FL-727  
P1657 ..... FL-733  
P1658 ..... FL-738  
P1659 ..... FL-744  
P1999 ..... FL-749

# DTC TROUBLESHOOTING PROCEDURES

## SCHEMATIC DIAGRAM E18EEEE3

### STARTING AND CHARGING SYSTEM(1)-D6CA ENGINE

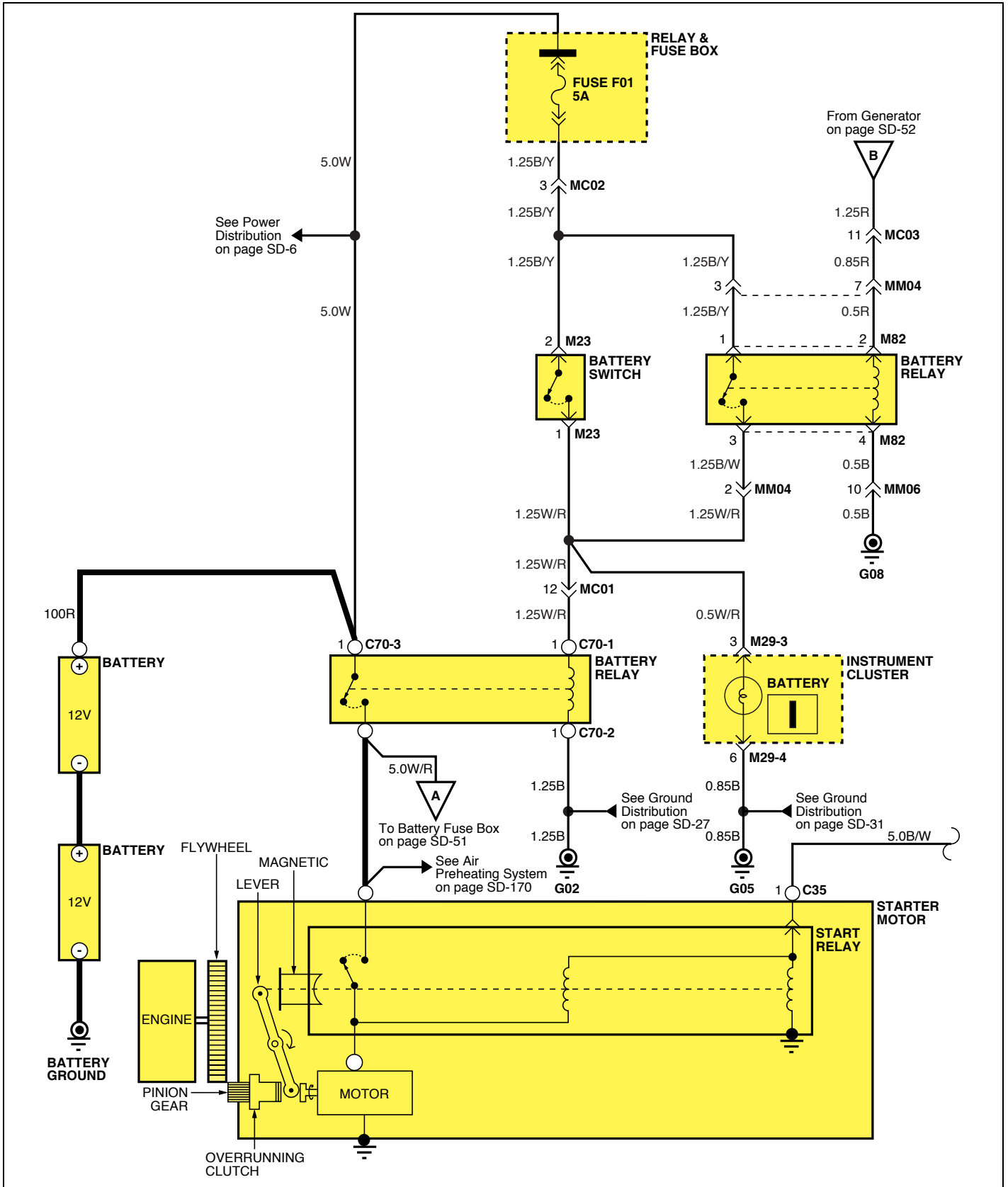

STARTING AND CHARGING SYSTEM(2)-D6CA ENGINE

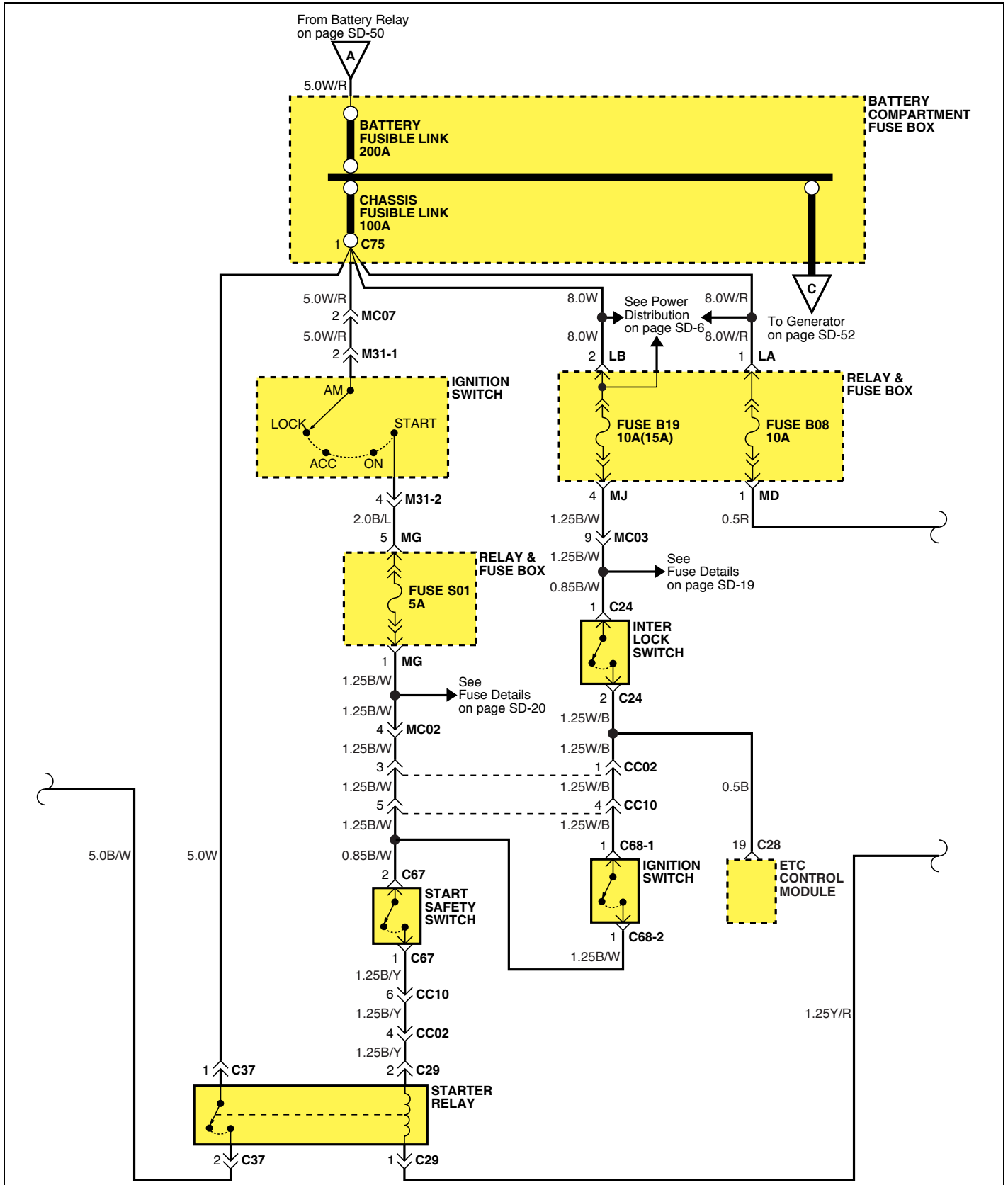

STARTING AND CHARGING SYSTEM(3)-D6CA ENGINE

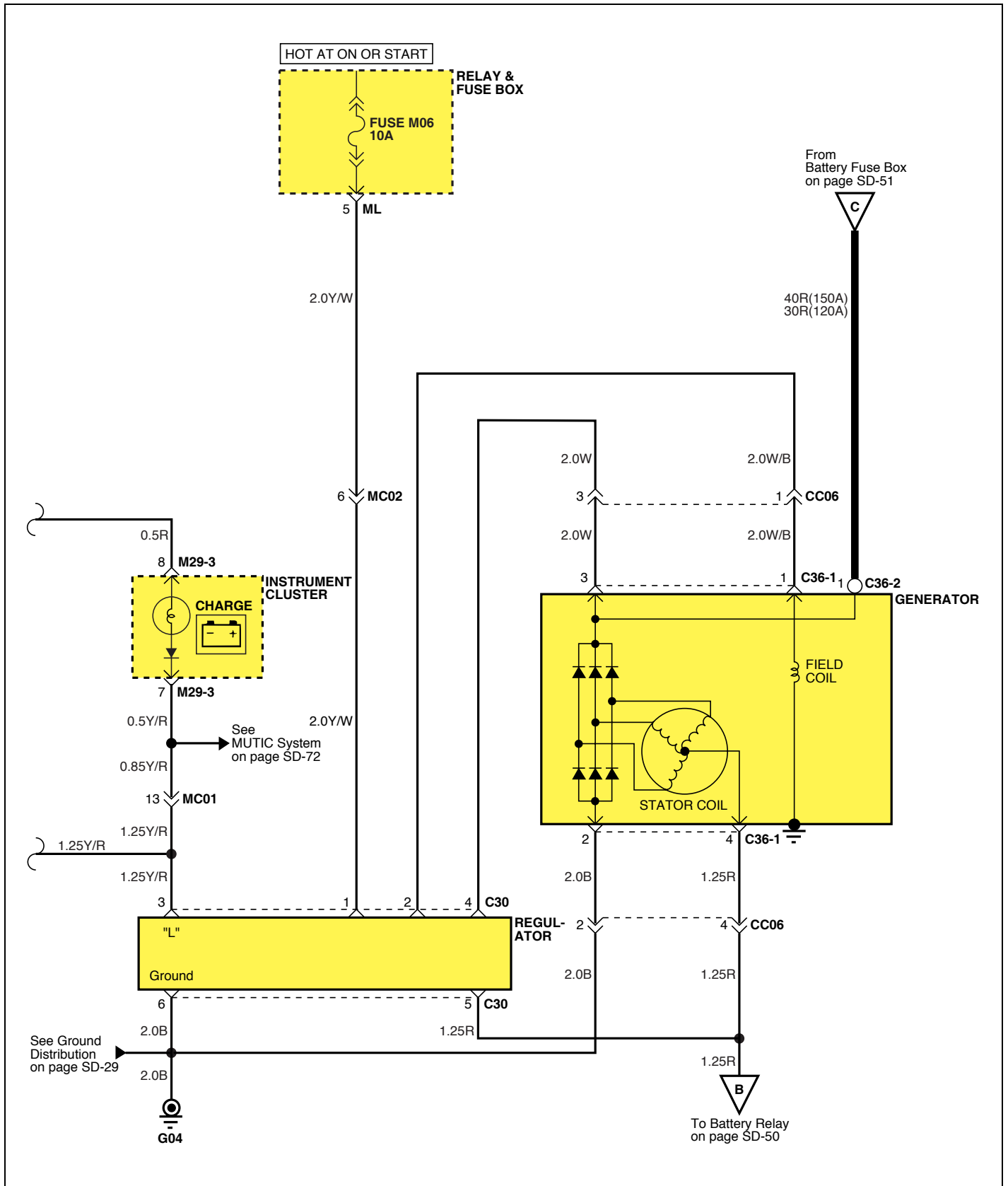

ELECTRICAL TIMING CONTROL(ETC) SYSTEM(1)-D6CA ENGINE

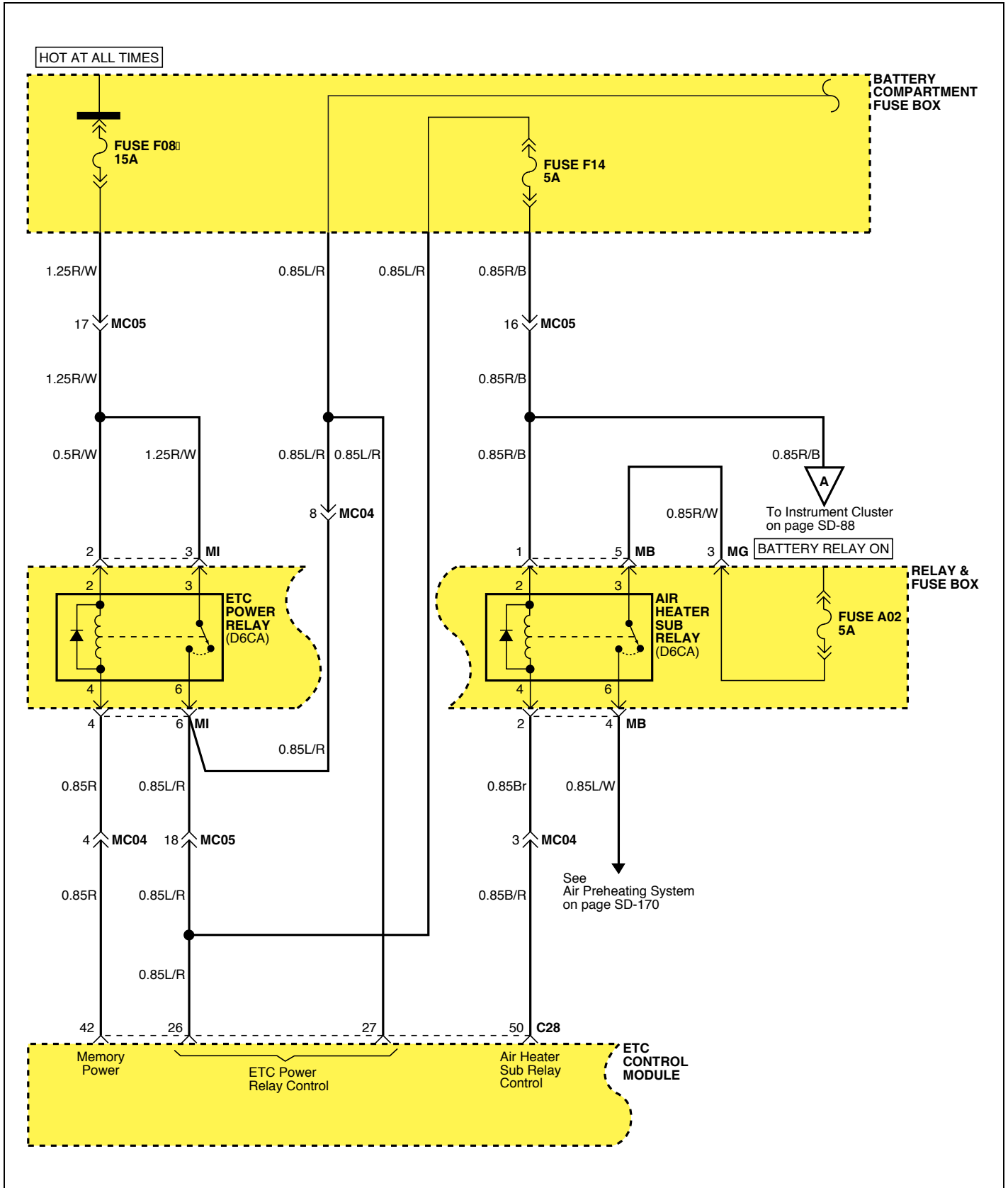

ELECTRICAL TIMING CONTROL(ETC) SYSTEM(2)-D6CA ENGINE

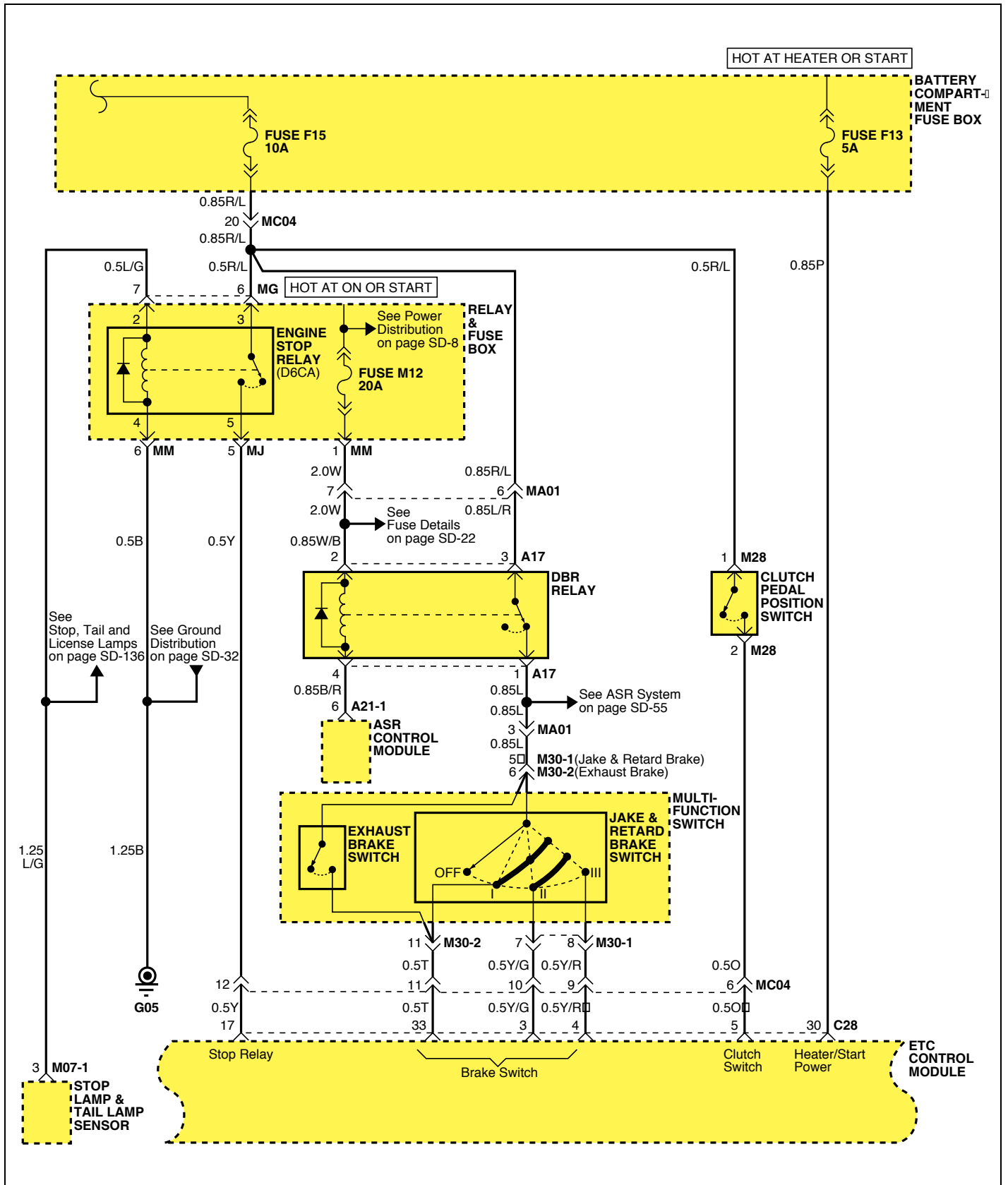

ELECTRICAL TIMING CONTROL(ETC) SYSTEM(3)-D6CA ENGINE

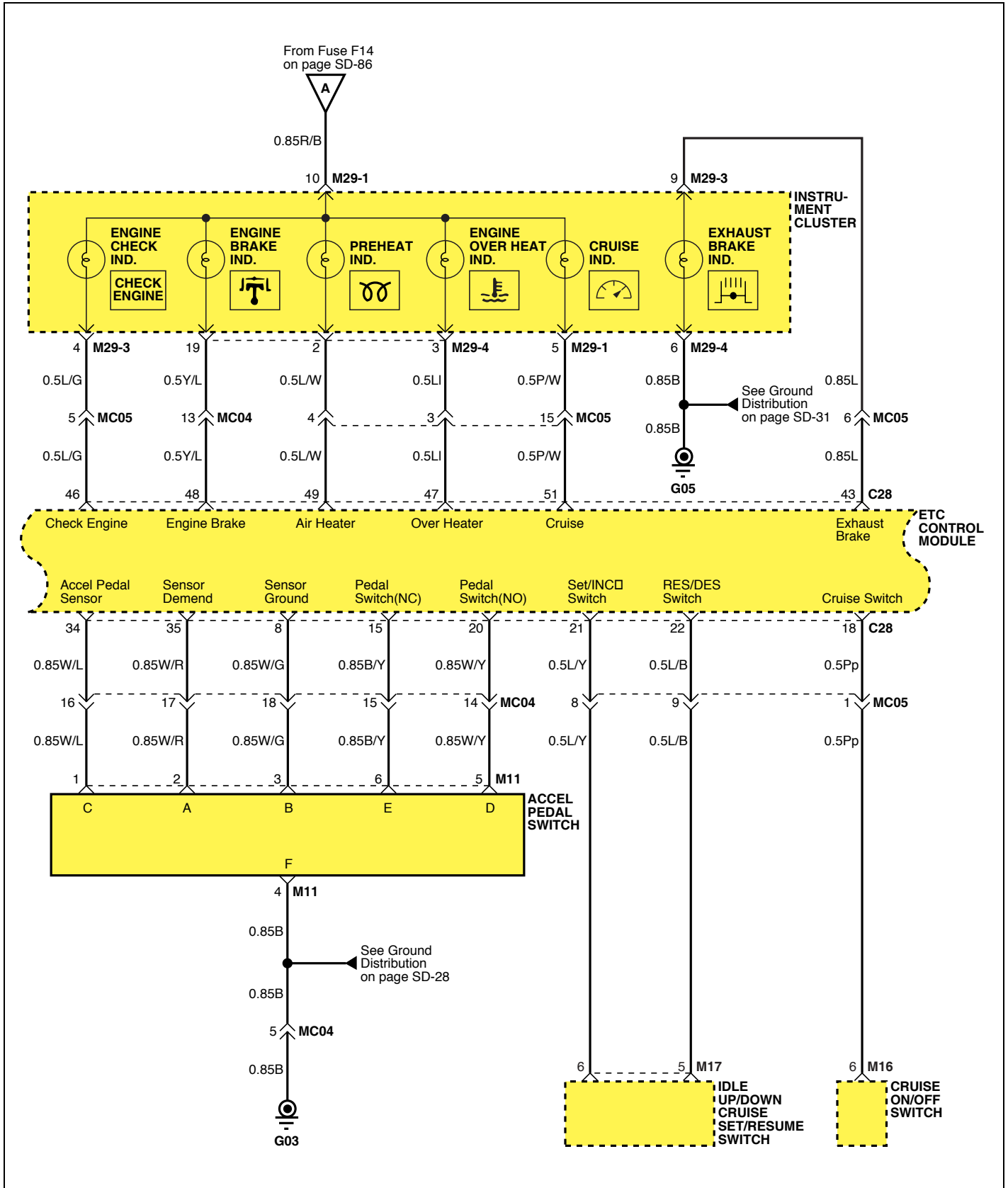



ELECTRICAL TIMING CONTROL(ETC) SYSTEM(4)-D6CA ENGINE

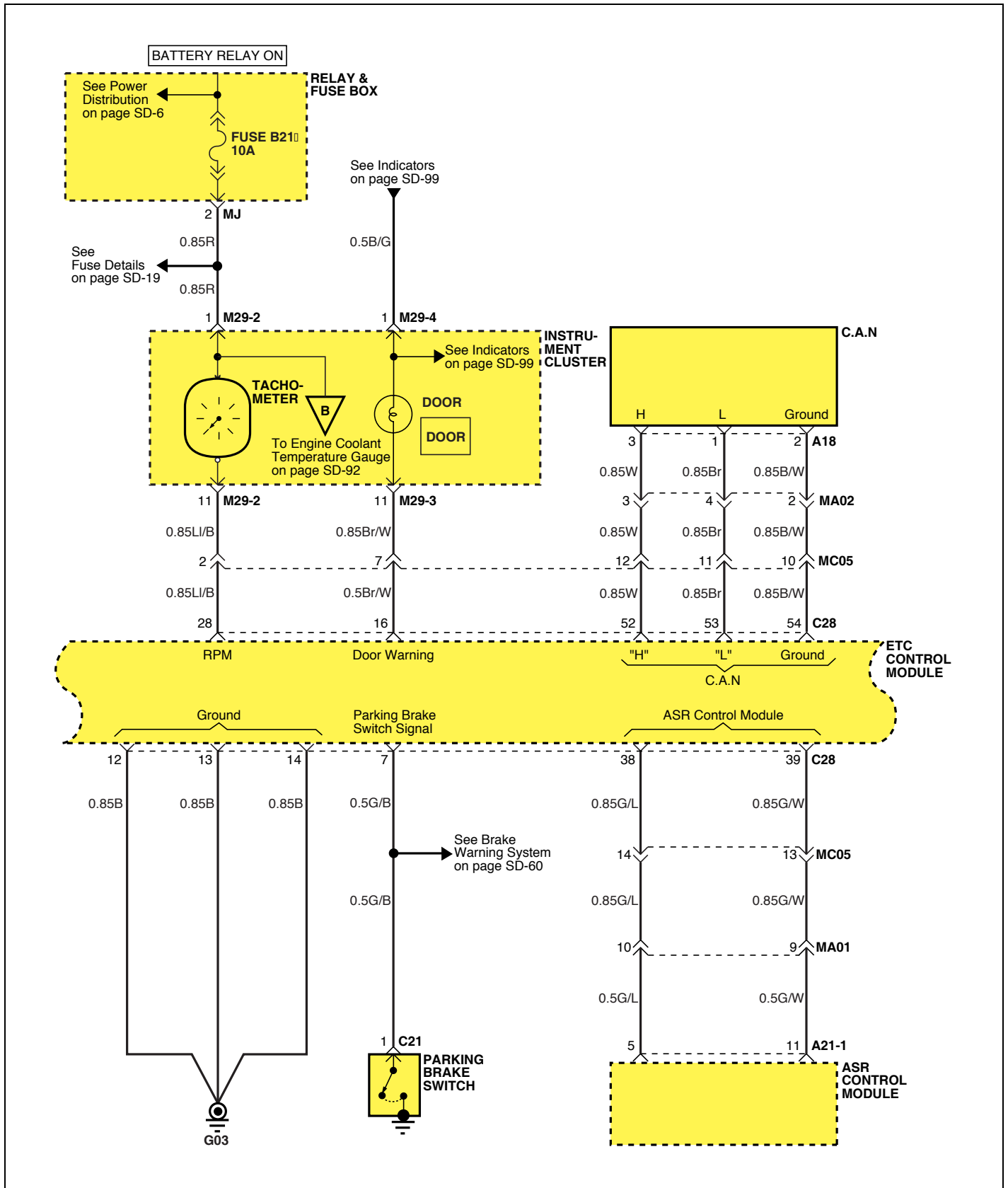

ELECTRICAL TIMING CONTROL(ETC) SYSTEM(5)-D6CA ENGINE

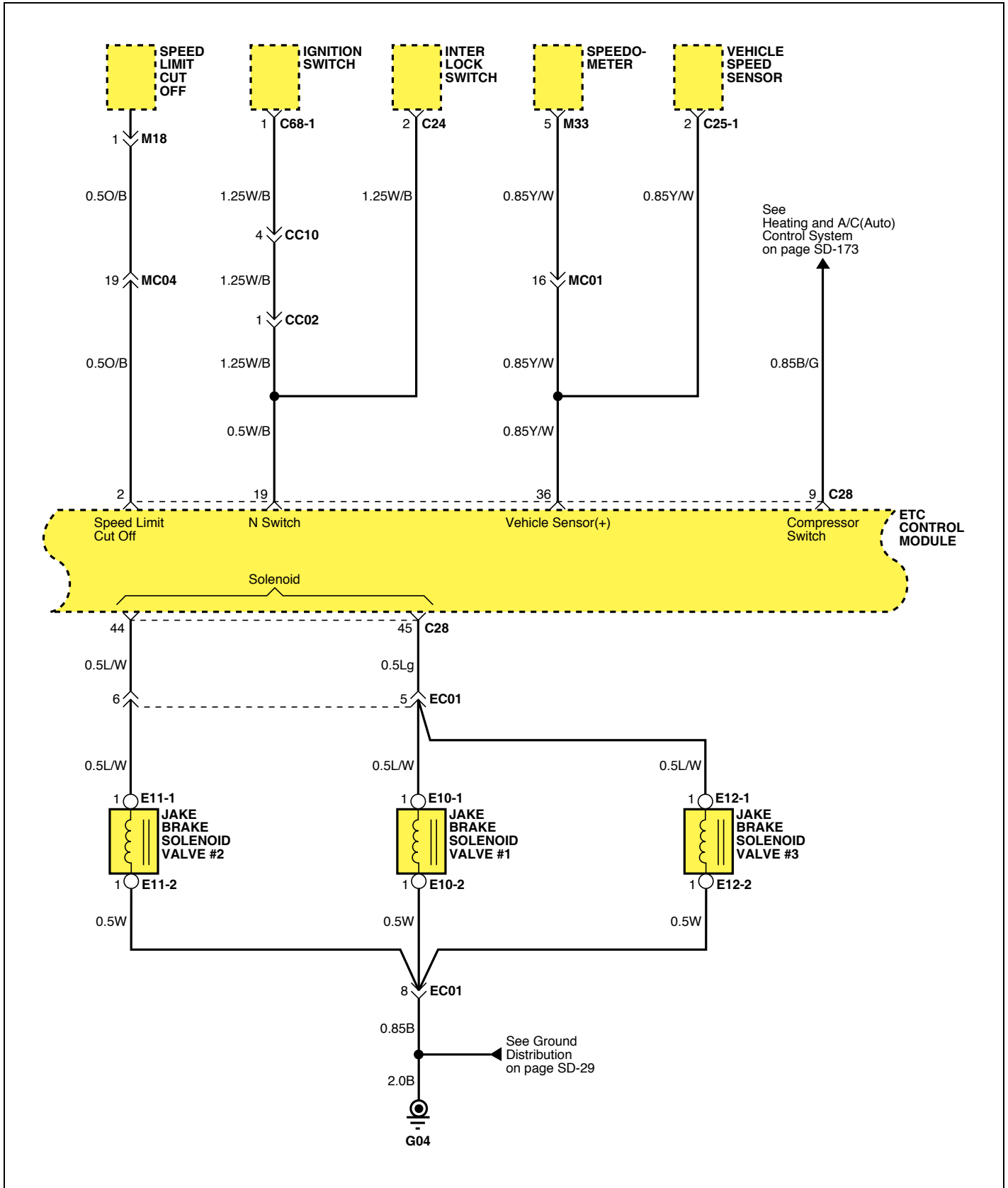



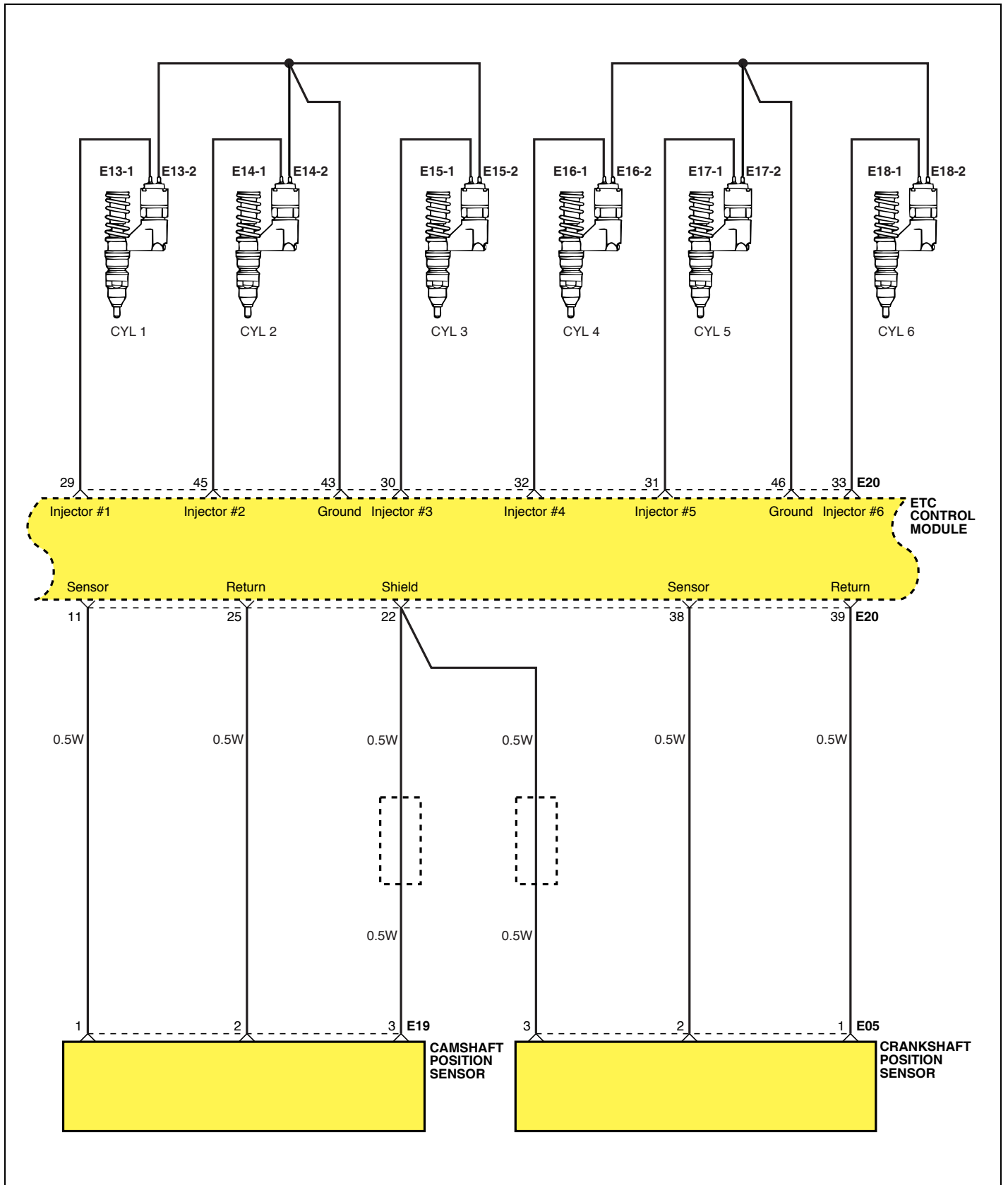



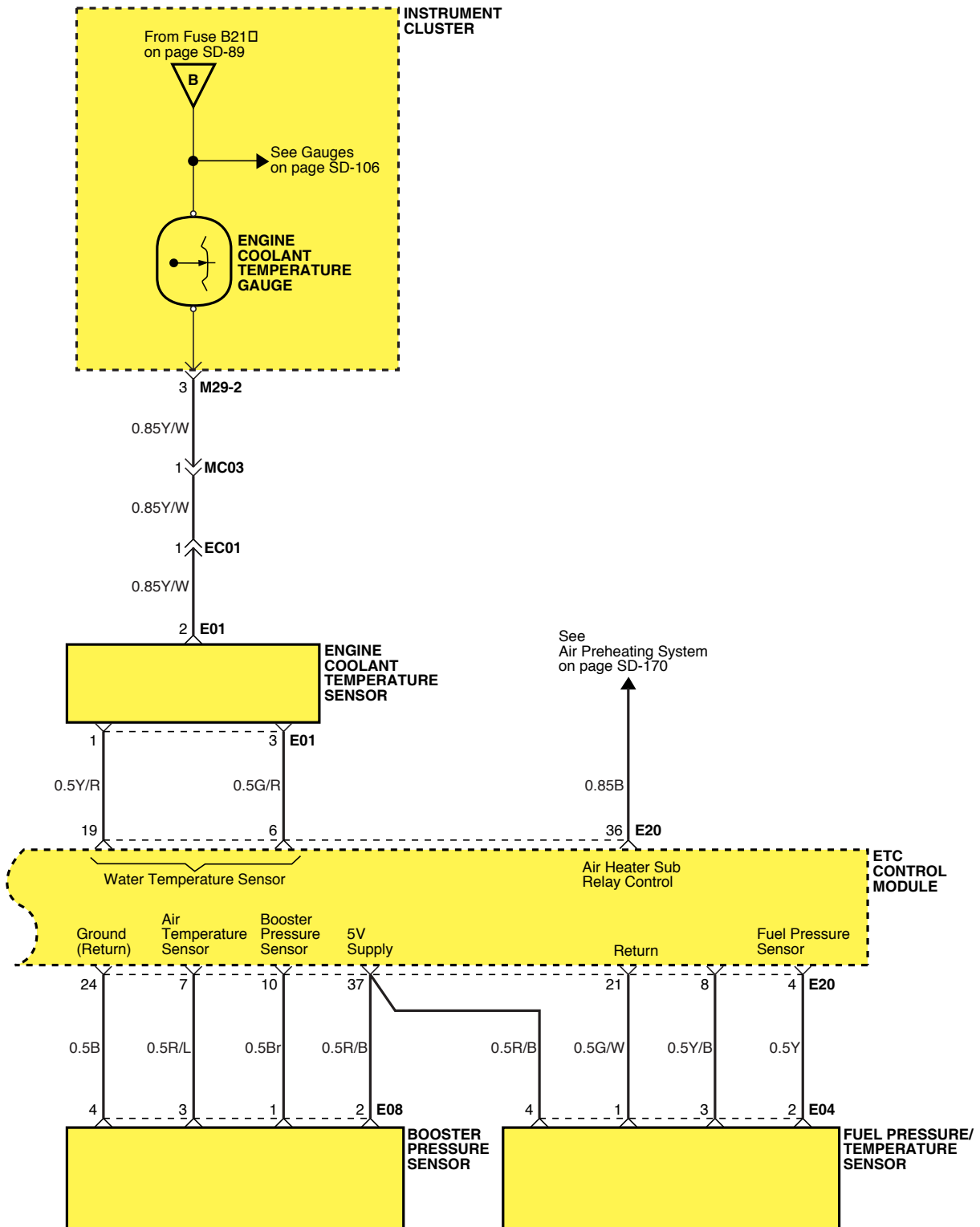



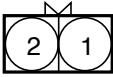
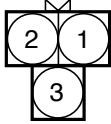

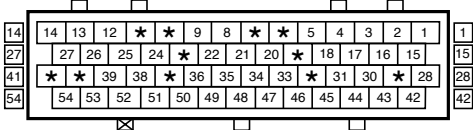
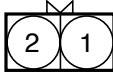
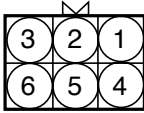
ELECTRICAL TIMING CONTROL(ETC) SYSTEM(6)-D6CA ENGINE

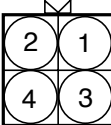

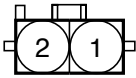
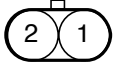
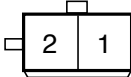
ELECTRICAL TIMING CONTROL(ETC) SYSTEM(7)-D6CA ENGINE

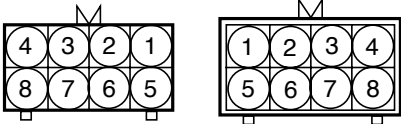
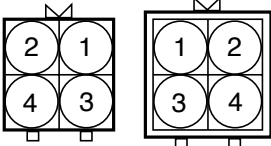
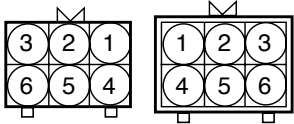

D6CA ENGINE CONNECTOR(1)

<p><b>C24</b></p>  <p>CR02F049</p>	<p><b>C25-1</b></p>  <p>CR03F022</p>	<p><b>C25-2</b></p>  <p>CR01F038</p>	<p><b>BLANK</b></p>
<p><b>C28</b></p>  <p>CR54F001</p>		<p><b>C29</b></p>  <p>CR02F013</p>	<p><b>C30</b></p>  <p>CR06F001</p>
<p><b>C35</b></p>  <p>CR01F035</p>	<p><b>C36-1</b></p>  <p>CR04F027</p>	<p><b>C36-2</b></p>  <p>CR01F010</p>	<p><b>C37</b></p>  <p>CR02F100</p>
<p><b>C40</b></p>  <p>CR02F025</p>	<p><b>C67</b></p>  <p>CR02F046</p>	<p><b>C68-1</b></p>  <p>CR01F022</p>	<p><b>C68-2</b></p>  <p>CR01F022</p>
<p><b>C70-1</b></p>  <p>CR01F030</p>	<p><b>C70-2</b></p>  <p>CR01F034</p>	<p><b>C70-3</b></p>  <p>CR01F034</p>	<p><b>C75</b></p>  <p>CR01F010</p>
<p><b>CC02</b></p>  <p>CR08F005</p>		<p><b>CC06</b></p>  <p>CR04B007</p>	<p><b>CC10</b></p>  <p>CR06F004</p>

D6CA ENGINE CONNECTOR(2)

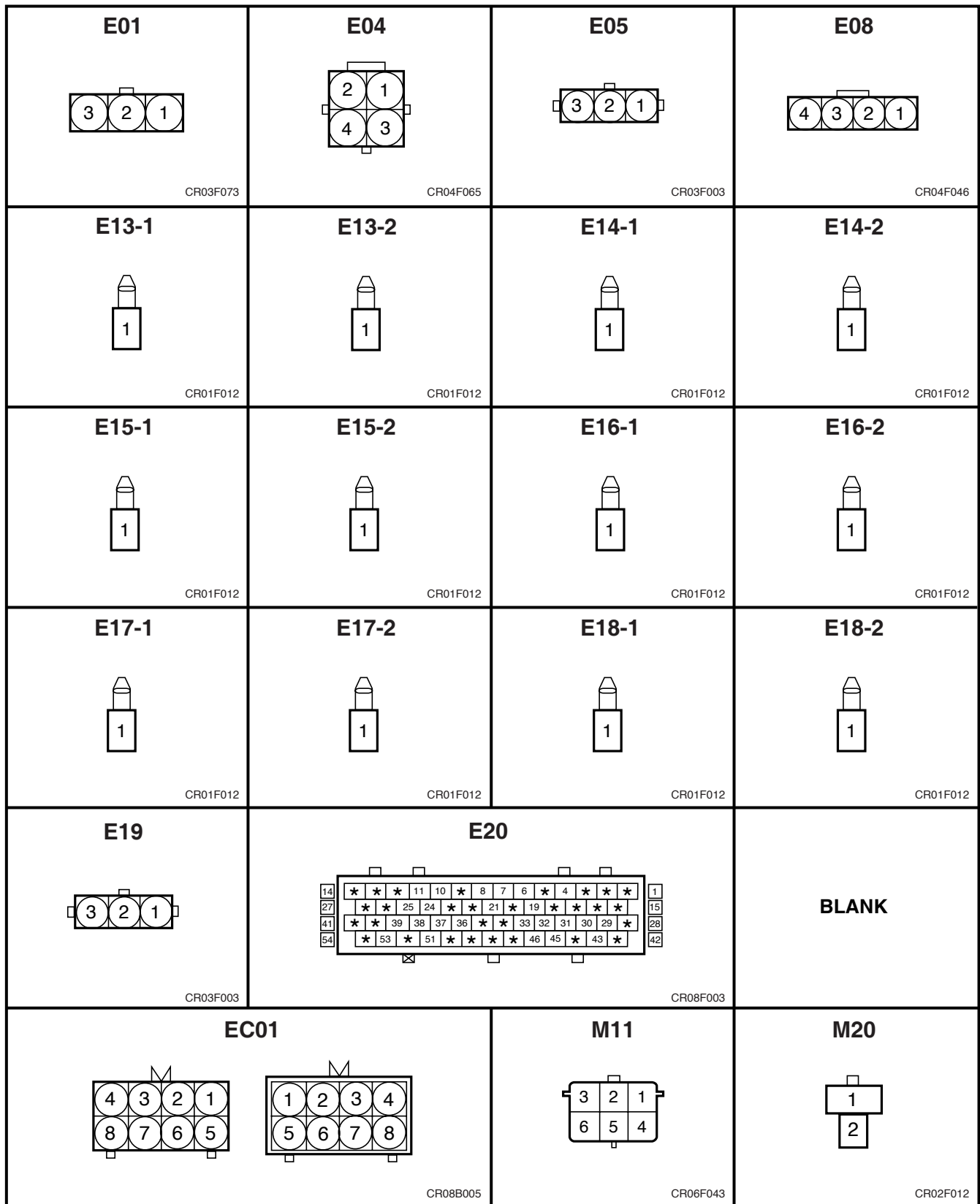

D6CA ENGINE CONNECTOR(3)

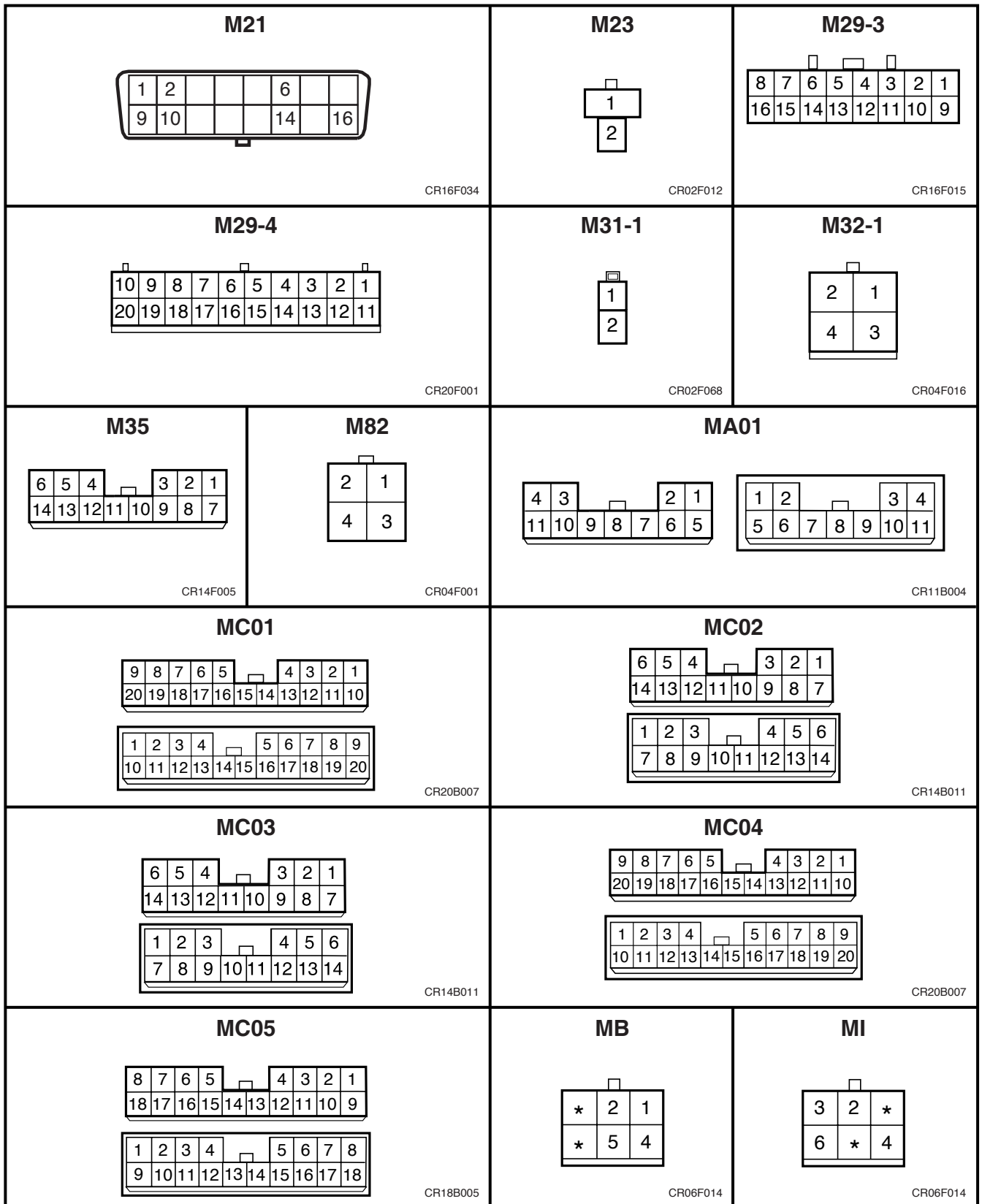

D6CA ENGINE CONNECTOR(4)

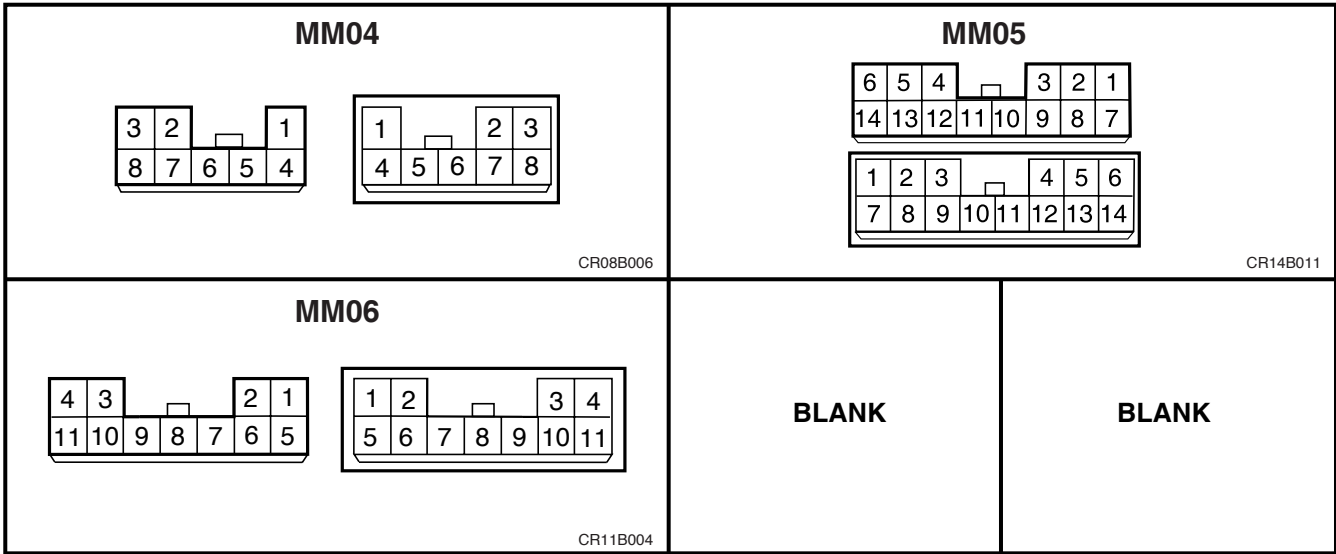



ENGINE CONTROL SYSTEM(1)-D6CB ENGINE

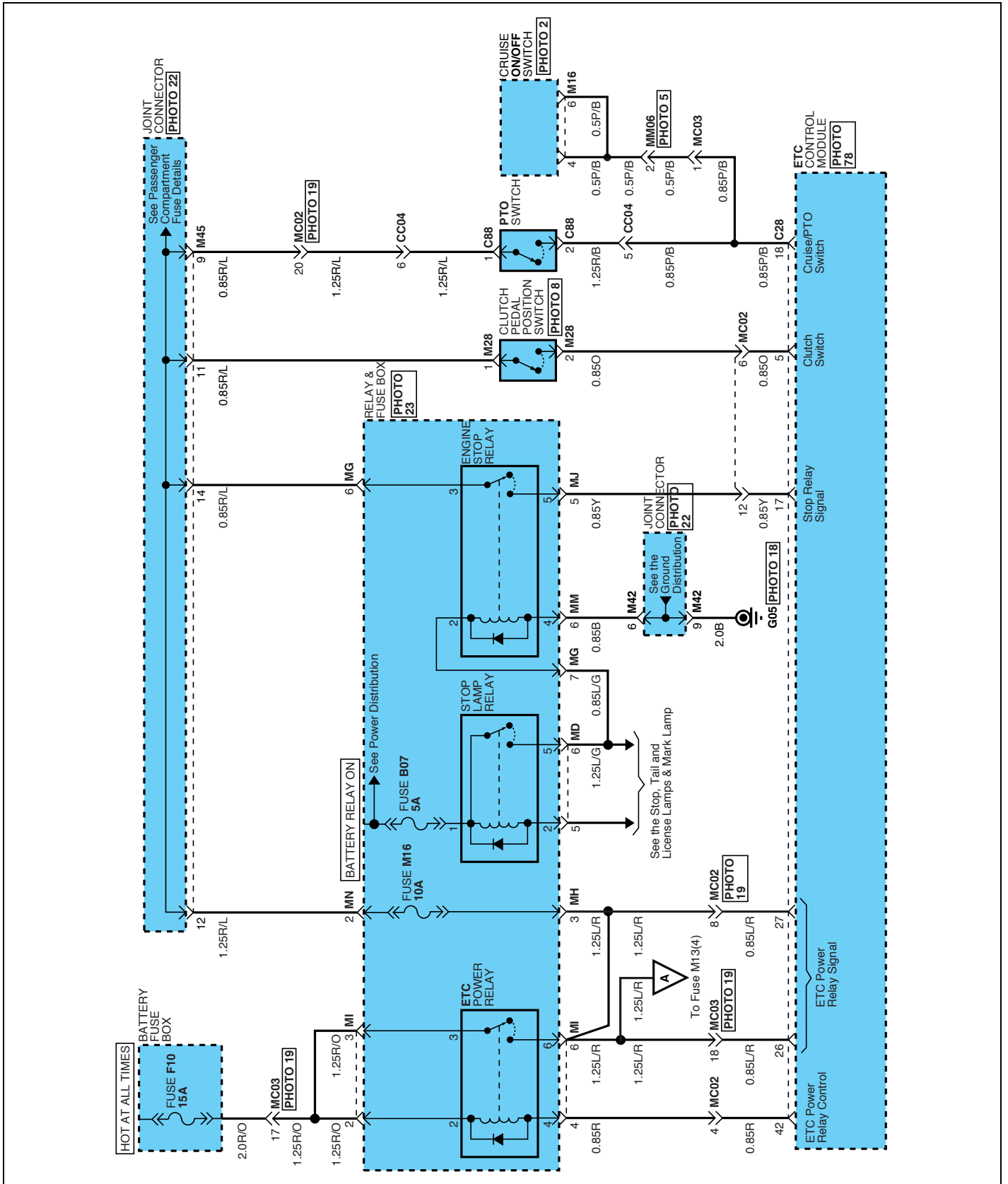

ENGINE CONTROL SYSTEM(2)-D6CB ENGINE

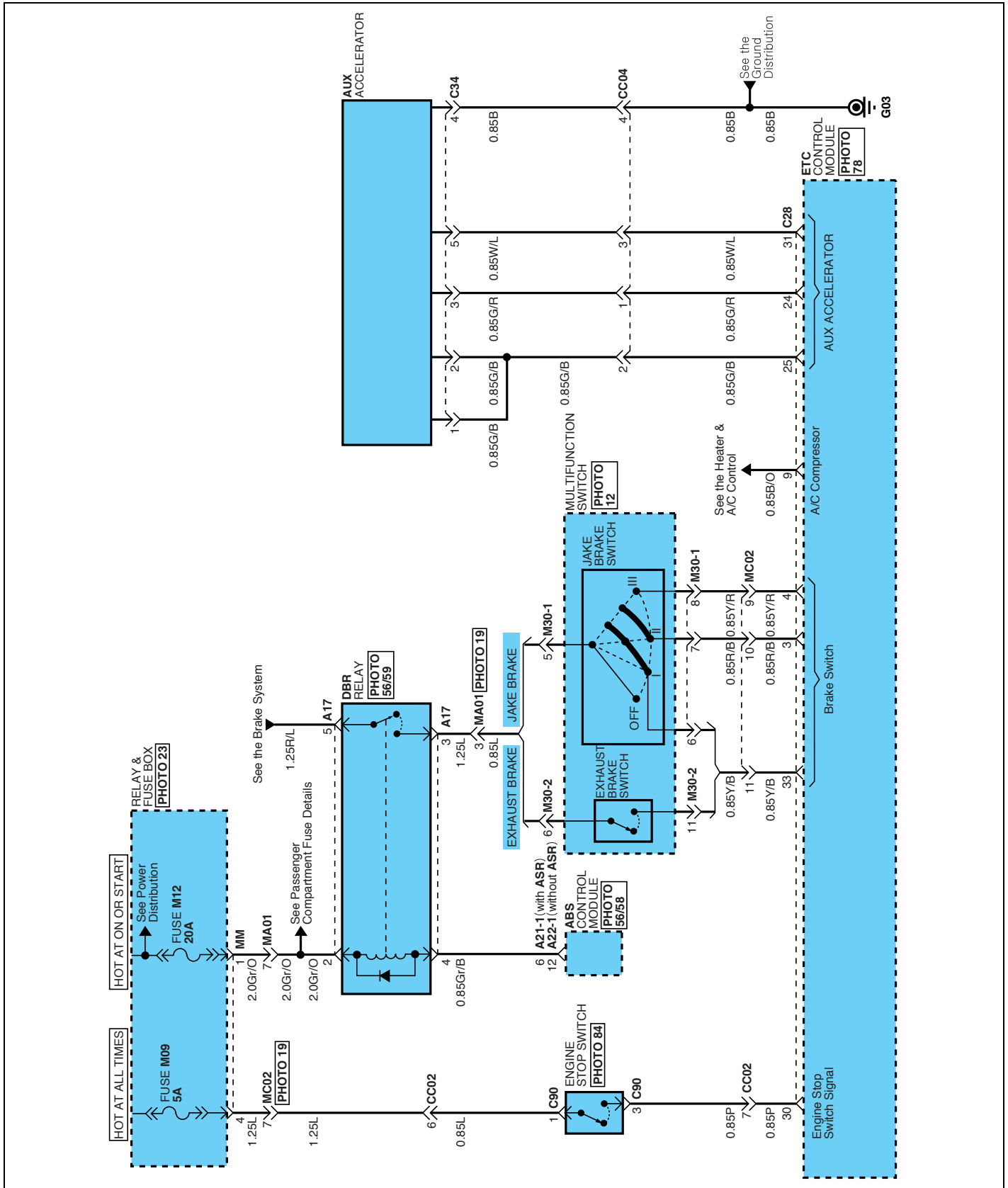

ENGINE CONTROL SYSTEM(3)-D6CB ENGINE

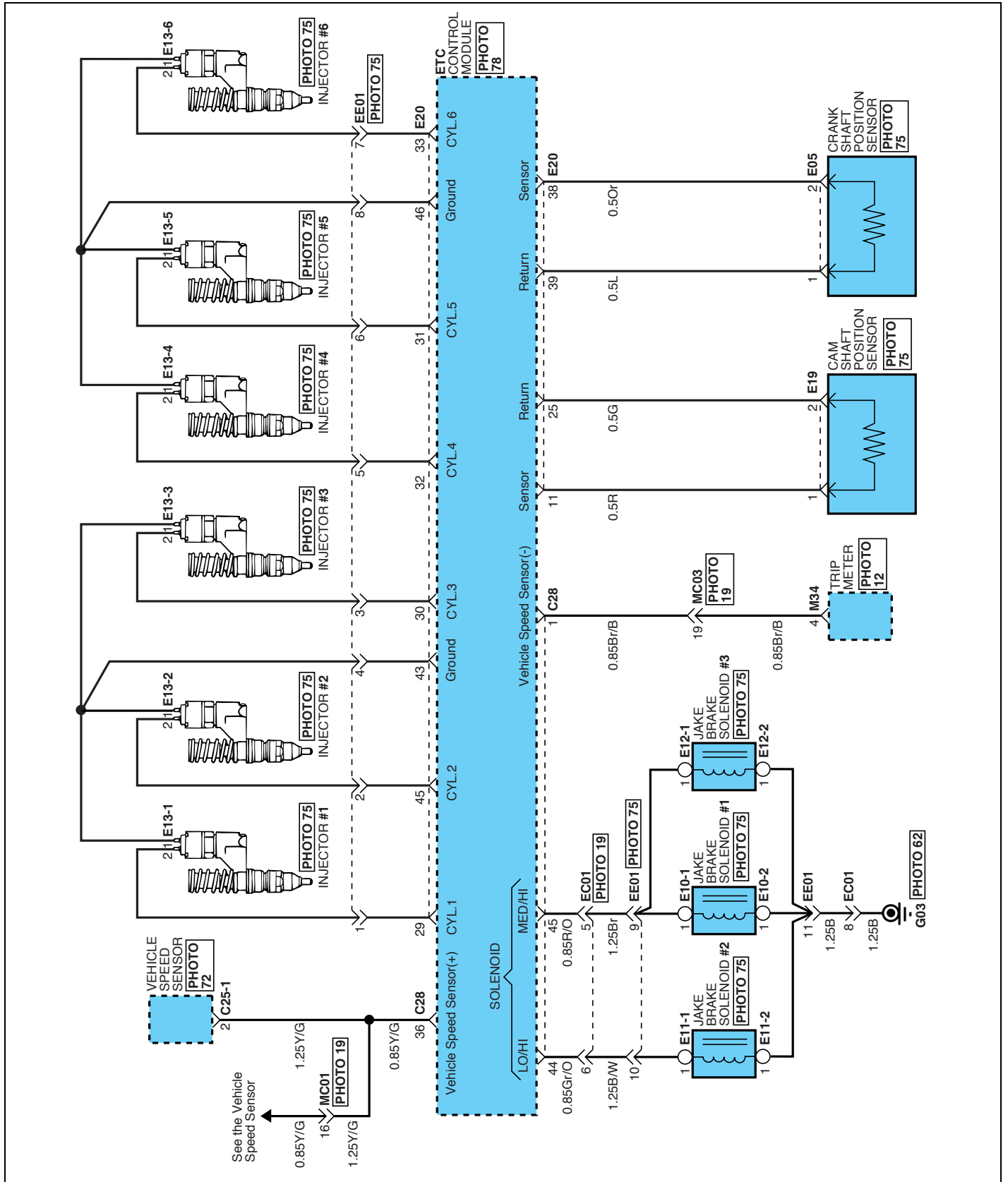

ENGINE CONTROL SYSTEM(4)-D6CB ENGINE

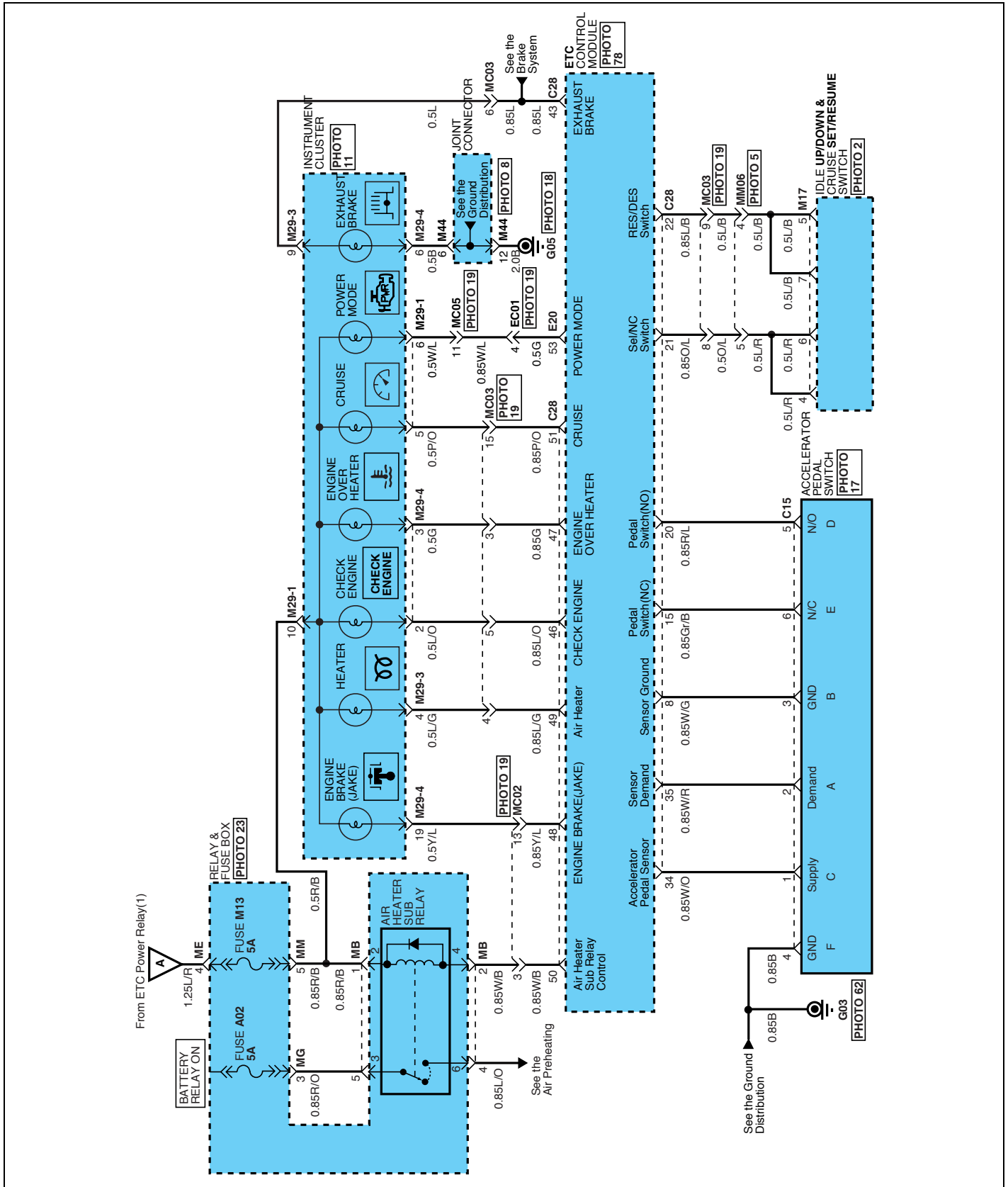

SMAFL6390L