

DIAGRAMS AND SCHEMATICS

**S30-35FT, S40FTS [E010];
H1.6-1.8FT, H2.0FTS (H30-35FT, H40FTS) [F001];
S2.0-3.5FT (S40-70FT, S55FTS) [G187];
H2.0-3.5FT (H40-70FT) [N177];
S4.0-5.5FT, S5.5FTS (S80-120FT, S80-100FTBCS, S120FTS,
S120FTPRS) [H004];
H4.0FT5/FT6, H4.5FTS5, H4.5FT6, H5.0-5.5FT
(H80-120FT) [S005];
S6.0-7.0FT (S135-155FT) [G024];
H6.0-7.0FT (H135-155FT) [K006];
H8.0-9.0FT, H8.0FT9 (H170-190FT, H175FT36) [B299]**

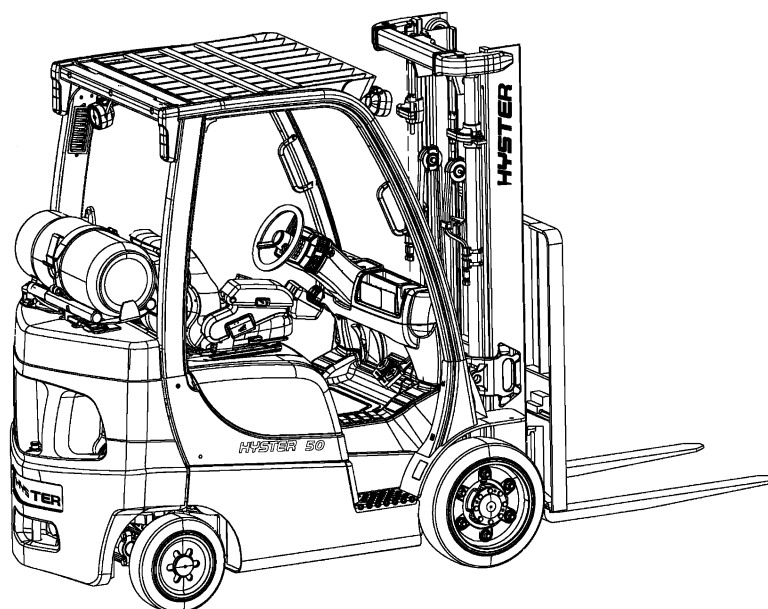

HYSTER

SAFETY PRECAUTIONS

MAINTENANCE AND REPAIR

- The Service Manuals are updated on a regular basis, but may not reflect recent design changes to the product. Updated technical service information may be available from your local authorized Hyster® dealer. Service Manuals provide general guidelines for maintenance and service and are intended for use by trained and experienced technicians. Failure to properly maintain equipment or to follow instructions contained in the Service Manual could result in damage to the products, personal injury, property damage or death.
- When lifting parts or assemblies, make sure all slings, chains, or cables are correctly fastened, and that the load being lifted is balanced. Make sure the crane, cables, and chains have the capacity to support the weight of the load.
- Do not lift heavy parts by hand, use a lifting mechanism.
- Wear safety glasses.
- DISCONNECT THE BATTERY CONNECTOR before doing any maintenance or repair on electric lift trucks. Disconnect the battery ground cable on internal combustion lift trucks.
- Always use correct blocks to prevent the unit from rolling or falling. See HOW TO PUT THE LIFT TRUCK ON BLOCKS in the **Operating Manual** or the **Periodic Maintenance** section.
- Keep the unit clean and the working area clean and orderly.
- Use the correct tools for the job.
- Keep the tools clean and in good condition.
- Always use **HYSTER APPROVED** parts when making repairs. Replacement parts must meet or exceed the specifications of the original equipment manufacturer.
- Make sure all nuts, bolts, snap rings, and other fastening devices are removed before using force to remove parts.
- Always fasten a DO NOT OPERATE tag to the controls of the unit when making repairs, or if the unit needs repairs.
- Be sure to follow the **WARNING** and **CAUTION** notes in the instructions.
- Gasoline, Liquid Petroleum Gas (LPG), Compressed Natural Gas (CNG), and Diesel fuel are flammable. Be sure to follow the necessary safety precautions when handling these fuels and when working on these fuel systems.
- Batteries generate flammable gas when they are being charged. Keep fire and sparks away from the area. Make sure the area is well ventilated.

NOTE: The following symbols and words indicate safety information in this manual:



WARNING

Indicates a hazardous situation which, if not avoided, could result in death or serious injury.



CAUTION

Indicates a hazardous situation which, if not avoided, could result in minor or moderate injury and property damage.

On the lift truck, the **WARNING** symbol and word are on orange background. The **CAUTION** symbol and word are on yellow background.

TABLE OF CONTENTS

General Information About Diagrams and Schematics	1
Symbol Definitions	2
Diagrams Manual Applications	2
Diagrams and Schematics	3

This section is for the following models:

(S30-35FT, S40FTS) [E010];
 H1.6-1.8FT, H2.0FTS (H30-35FT, H40FTS) [F001];
 S2.0-3.5FT (S40-70FT, S55FTS) [G187];
 H2.0-3.5FT (H40-70FT) [N177];
 S4.0-5.5FT, S5.5FTS (S80-120FT, S80-100FTBCS, S120FTS, S120FTPRS)
 [H004];
 H4.0FT5/FT6, H4.5FTS5, H4.5FT6, H5.0-5.5FT (H80-120FT) [S005];
 S6.0-7.0FT (S135-155FT) [G024];
 H6.0-7.0FT (H135-155FT) [K006];
 H8.0-9.0FT, H8.0FT9 (H170-190FT, H175FT36) [B299]

**"THE
QUALITY
KEEPERS"**

**HYSTER
APPROVED
PARTS**

General Information About Diagrams and Schematics

The chassis wiring used in these vehicles conforms to the electrical circuit identification standard **ES-1359** and in addition to surface marked ID circuit numbers, generally utilizes the colors that are indicated in Table 1.

MONOTROL[®], engine harnesses, wiring to sensors, and other applications vary with respect to wire colors.

Diagrams and schematics in this manual can be viewed and printed in color. If not printed or viewed in color, refer to the electrical circuit

identification located on schematic circuits. When viewing a color version of the diagrams and schematics, the white chassis wires are seen as yellow. Other wires are shown in colors similar to actual colors, i.e. tan shows as yellow. Use circuit identification for true wire color.

Refer to **Diagnostic Troubleshooting Manual** 9000SRM1112 Section 9030, Group 03 - General Maintenance and Diagnostic Data, for further information.

Table 1. Wire Colors

Color	Use/Function
Red	Battery-level power circuits and 5 volt supply circuits
Black	Heavy current grounds
Green	Signal grounds
White	Other circuits
Twisted Pair (Yellow/Green) Yellow Green	CANbus CAN-Hi CAN-Lo
Twisted Pair (Dk Blue/Pink and Dk Blue/White) Dk Blue/Pink Dk Blue/White	CANbus (Mazda) CAN-Hi CAN-Lo
Letter on the VSM BUS	Use/Function
R	Regulated Output Voltage
D	Driver
I	Input

SYMBOL DEFINITIONS

See Table 2 for description of symbol definitions.

Table 2. Symbol Definitions

Symbol Name	Definition
Type S	Identifies information for UL Safety rated trucks. Applicable trucks are rated for GS, LPS, and DS depending on fuel type.
Arrow Symbol 	Go to specified page of schematic, located in lower right corner in the hexagon symbol.
----X	Go to specified sheet of diagram. Sheet number is located in lower right corner of figure.

DIAGRAMS MANUAL APPLICATIONS

See Table 3 for the correct diagrams service manual for your lift truck.

Table 3. 1-9 Ton Diagrams Manual Applications

Unit Code	Production Date	Electrical Schematic	Wiring Diagram	Diagrams Manual Number
E010, F001	Prior to August 2008	8525590	8516519	8000 SRM 1152
	August, 2008 to April, 2009	1665405	1665404	8000 SRM 1387
	May, 2009 to December 2012	1688540	1688539	8000 SRM 1409
	January, 2013 to April 2014	4051618	4051617	8000 SRM 1585
	April, 2014 ==>	4100474	4100473	8000 SRM 1689
F187, L177	Prior to August 2008	8525590	8516519	8000 SRM 1152
	August, 2008 to April, 2009	1665405	1665404	8000 SRM 1387
	May, 2009 to December 2012	1688540	1688539	8000 SRM 1409
	January, 2013 ==>	4051618	4051617	8000 SRM 1585

Table 3. 1-9 Ton Diagrams Manual Applications (Continued)

Unit Code	Production Date	Electrical Schematic	Wiring Diagram	Diagrams Manual Number
G004	Prior to August 2008	8525590	8516519	8000 SRM 1152
	August, 2008 to December 2009	1665405	1665404	8000 SRM 1387
	January 2010 to January 2012	1688540	1688539	8000 SRM 1409
	January 2012 ==>	4051618	4051617	8000 SRM 1585
N005, D024, H006	All	8525590	8516519	8000 SRM 1152
E024	August, 2008 to April, 2009	1665405	1665404	8000 SRM 1387
	May, 2009 ==>	1688540	1688539	8000 SRM 1409
J006	August, 2008 to April, 2009	1665405	1665404	8000 SRM 1387
	May, 2009 ==>	1688540	1688539	8000 SRM 1409
F024	All	4051618	4051617	8000 SRM 1585
K006	Prior to April 2014	4051618	4051617	8000 SRM 1585
	April 2014 ==>	4100474	4100473	8000 SRM 1689
P005	Prior to January 2010	1665405	1665404	8000 SRM 1387
	January 2010 ==>	1688540	1688539	8000 SRM 1409
R005	All	4051618	4051617	8000 SRM 1585
G024	Prior to April 2014	4051618	4051617	8000 SRM 1585
	April 2014 ==>	4100474	4100473	8000 SRM 1689
S005	Prior to April 2014	4051618	4051617	8000 SRM 1585
	April 2014 ==>	4100474	4100473	8000 SRM 1689
H004	Prior to April 2014	4051618	4051617	8000 SRM 1585
	April 2014 ==>	4100474	4100473	8000 SRM 1689
A299	May, 2009 ==>	1688540	1688539	8000 SRM 1409
B299	Prior to April 2014	4051618	4051617	8000 SRM 1585
	April 2014 ==>	4100474	4100473	8000 SRM 1689

Diagrams and Schematics

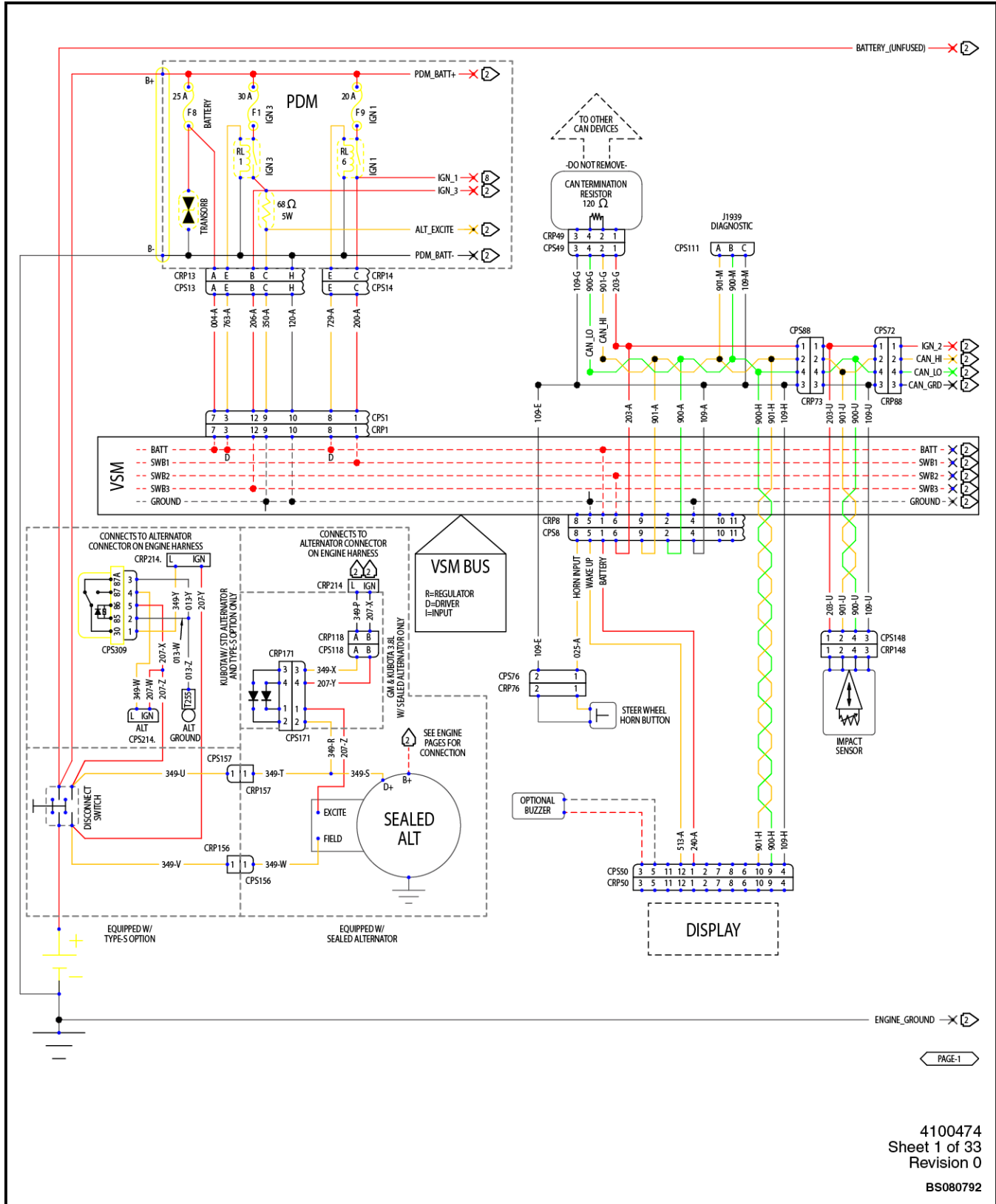

Figure 1. Type S Option Electrical Schematic

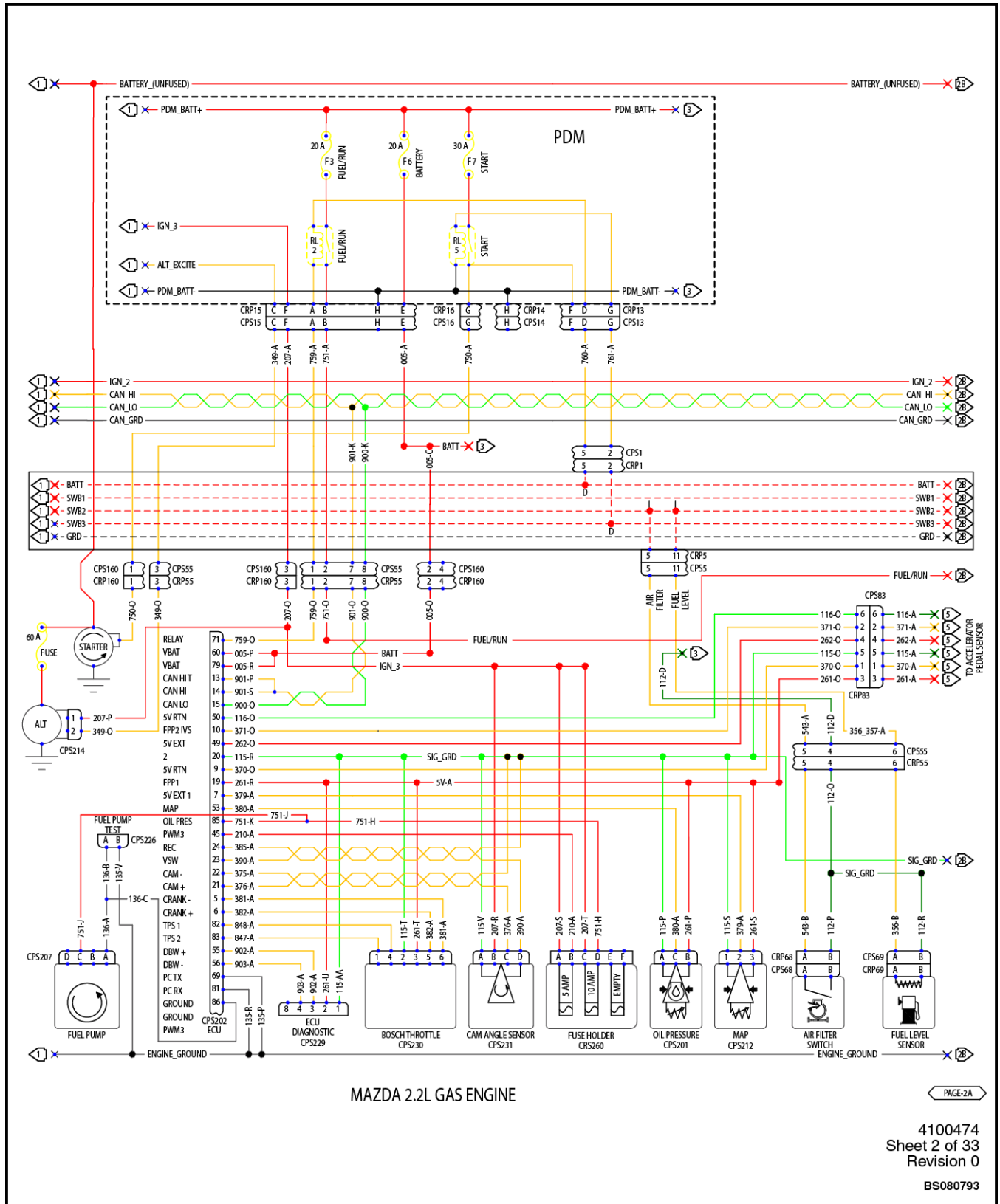

Figure 2. Mazda (2010) 2.2L Gas Engine Electrical Schematic (Sheet 1 of 2)