



ELANTRA

Body Repair Manual

INTRODUCTION

This Body Repair Manual provides detailed repair procedures for repair of commonly damaged structural panels on the Hyundai 2007 ELANTRA(HD). To aid in the information of the damaged vehicle, body construction, replacement parts, body dimensions, body sealing locations, corrosion protection, body modification tools, plastic parts and body repair procedures are contained herein.

The repair procedures specify locations where body members may be structurally sectioned. All of the repair procedures have been performed on Hyundai ELANTRA(HD) body shells and that is currently available in most auto body repair shops.

The repair procedures illustrated in this manual were developed to simplify body repair in order to reduce insurance costs, and indirectly, cost of ownership.

The vehicle should not be sectioned in locations other than those illustrated in this repair manual. Furthermore, these repair procedures DO NOT apply to any other vehicle. The individuals performing the work must assume full responsibility for the quality of their workmanship.

We believe this manual to be helpful for Hyundai dealers, and anticipate it to be effectively used for Hyundai vehicle bodies.

For the services of other than collision-damaged body parts of the Hyundai ELANTRA(HD), refer to the ELANTRA(HD) shop manual.

The illustrations and descriptive text in this manual were correct at the time of printing. It is the policy of HYUNDAI MOTOR COMPANY to continuously improve its products. Specifications and procedures are subject to change at any time without notice.

April 2006, Printed in Korea

All rights reserved. No part of this publication may be reproduced, stored in any retrieval system or transmitted in any form or by any means without the prior written permission of Hyundai Motor Company.

CONTENTS

GENERAL INFORMATION

GENERAL GUIDE LINES AND PRECAUTIONS	GI-2
SRS AIR-BAG	GI-3
ELECTRONIC PARTS	GI-4
CORROSION PROTECTION AND SEALING	GI-4
SIDE BODY PANELS	GI-4
WELDING	GI-5

BODY CONSTRUCTION

FRONT & REAR BODY	BC-2
SIDE BODY	BC-3

BODY DIMENSIONS

GENERAL	BD-2
MEASUREMENT METHOD	BD-2
FRONT BODY	BD-4
SIDE BODY	BD-6
INTERIOR A	BD-8
INTERIOR B	BD-11
REAR BODY	BD-13
UNDER BODY (PROJECTED DIMENSIONS)	BD-15
UNDER BODY (ACTUAL-MEASUREMENT DIMENSIONS)	BD-18

BODY PANEL REPAIR PROCEDURE

FENDER APRON PANEL ASSEMBLY	BP-2
FRONT SIDE MEMBER(PARTIAL)	BP-7
FRONT PILLAR	BP-11
SIDE SILL (PARTIAL)	BP-19
CENTER PILLAR	BP-22
QUARTER PANEL	BP-31
BACK COMPLETE PANEL ASSEMBLY AND REAR FLOOR SIDE MEMBER	BP-36

BODY SEALING LOCATION

FLOOR	BS-2
UPPER AND SIDE BODY	BS-5
UNDER BODY	BS-8
HOOD	BS-9
TRUNK LID	BS-10

CORROSION PROTECTION

ZINC-PHOSPHATE COAT & CATIONIC ELECTRODEPOSITION PRIMER	CP-2
ANTIVIBRATION PADS-LOCATION & SECTION	CP-3
ATTACHMENT OF ANTIVIBRATION PADS	CP-6
UNDER BODY COAT	CP-7
SIDE BODY	CP-8
CAVITY WAX INJECTION	CP-9
UNDERBODY ANTI-CORROSION AGENT	CP-10

GI

BC

BD

BP

BS

CP

BT

PP

GENERAL INFORMATION

GENERAL GUIDE LINES AND PRECAUTIONS

The Hyundai ELANTRA is a completely new vehicle design. During its development, close attention has been given to safety, stability, weight and corrosion protection. Typical of unit body design, the Hyundai ELANTRA is designed so that the front and rear compartments will absorb much of the collision energy so that the passengers are better protected. During collisions, these front and rear energy absorbing systems may be severely damaged. During repair, these damaged areas must be returned to their original strength and geometry. If this is not properly done, the vehicle will not provide the intended level of protection to its occupants in the event of another collision.

The repairs described in this manual were performed on ELANTRA body shells. In some instances special fixtures were welded in place to support the structure. During the repair of an actual vehicle, the interior would be fully disassembled and standard jack screws or portable braces may be used for temporary support.

During the repair of an accident involved vehicle, the vehicle must first be returned to pre-impact dimensions prior to beginning the sectioning repair procedures. The extent of damage that must be repaired should then be evaluated to determine the appropriate repair procedures. This manual provides locations and procedures where structural sectioning may be employed. It is the responsibility of the repair technician, based upon the extent of damage, to determine which location and procedure is suitable for the particular damaged vehicle.

During the repair of a collision damaged automobile, it is impossible to fully duplicate the methods used in the factory during the vehicle manufacture. Therefore, auto body repair techniques have been developed to provide a repair that has strength properties equivalent to those of the original design and manufacture.

Certain guidelines and precaution are noted as follow.

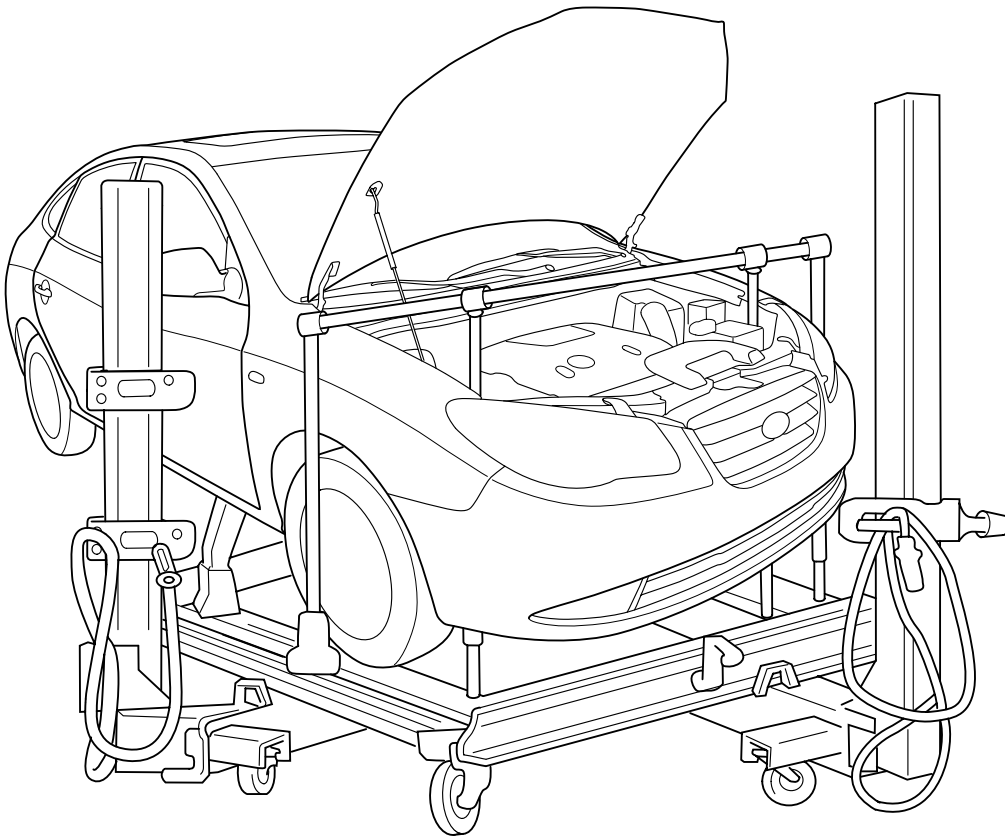

SRS AIR-BAG

SYSTEM COMPONENT

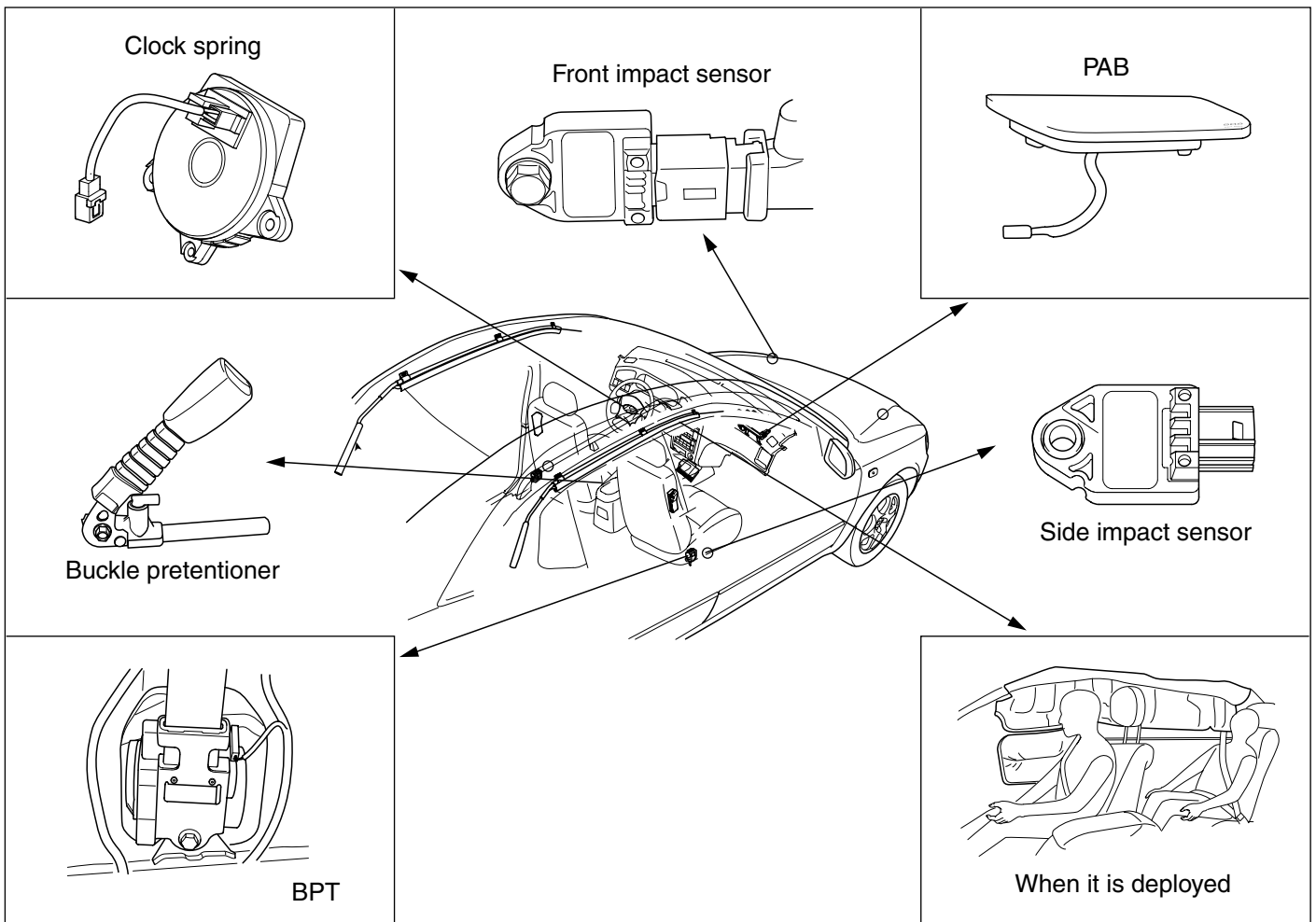

ERKB012A

The Hyundai ELANTRA is equipped with a Supplemental Restraint System AIR-BAG to provide the vehicle's driver and/or the front passenger with additional protection than that offered by the seat-belt system alone, in case of a frontal impact of sufficient severity.

When handling airbag components (removal, installation or inspection, etc.), always follow the directions given in the repair manual for the relevant model to prevent the occurrence of accidents and airbag malfunction.

Also take the following precautions when repairing the body:

1. Work must be started after approximately 30 seconds or longer from the time the ignition switch is turned to the LOCK position and the negative (-) terminal cable is disconnected from the battery. (The airbag system is equipped with a back-up power source so that if work is started within 30 seconds of disconnecting the negative (-) terminal cable of the battery, the airbag may be deployed.)
When the negative(-) terminal cable is disconnected from the battery, memory of the clock and audio systems will be cancelled. So before starting work, make a record of the contents memorized by the audio memory system. Then when work is finished, reset the audio system as before and adjust the clock.
2. When using electric welding, first disconnect the air-bag connectors under the steering column near the MULTI-FUNCTION SWITCH and the passenger's side crash pad before starting work.
3. Store the air-bag modules where the ambient temperature remains below 93°C(200°F), without high humidity and away from electrical noise.
4. WARNING/CAUTION labels are attached to the periphery of the air-bag components.
Refer to the ELANTRA SHOP MANUAL

ELECTRONIC PARTS

Vehicles today include a great many electronic parts and components, and these are in general very susceptible to adverse effects caused by overcurrent, reverse current, electromagnetic waves, high temperature, high humidity impacts, etc. In particular such electronic components can be damaged if there is a large current flow during welding from the body side. Therefore, take the following precautions during body repair to prevent damage to the CONTROL MODULES (ECM, TCM, ABS CM, SRS CM, etc.)

1. Before removing and inspecting the electrical parts or before starting electric welding operations, disconnect the negative (-) terminal cable from the battery.
2. Do not expose the CONTROL MODULES to ambient temperatures above 80°C(176°F).

NOTE

If it is possible the ambient temperatures may reach 80°C(176°F) or more, remove the CONTROL MODULES from the vehicle before starting work.

3. Be careful not to drop the CONTROL MODULES and not to apply physical shocks to them.

CORROSION PROTECTION AND SEALING

Proper corrosion protection and sealing is an important part of any repair. When reviewing these repair procedures, it is important to recognize the need for corrosion restoration to provide for long term strength of the repaired member.

A two part epoxy primer was applied to the metal surfaces during the latter part of the repair. For closed sections, such as front and rear rails, rocker panels and pillars, the primer is applied without applying the metal conditioner and the conversion coating. These steps are omitted to insure that no rinse water is trapped in the closed sections. The primer application is followed by an application of an oil or wax based rust proofing material.

After the corrosion restoration process for the closed sections are completed, then the process can be applied to all exterior sections. For exterior surfaces, both metal conditioner and conversion coating treatments are applied to the exterior surface prior to application of the epoxy primer. The procedure in applying the corrosion restoration process is important order to insure that moisture, due to the water rinsing of the metal conditioner and conversion coating is not inadvertently trapped inside any closed section before the epoxy primer and rust proofing materials have been applied.

Appropriate seam sealers are then applied to all joints. Follow manufacturer's recommendations for the appropriate type of seam sealer to be used at each seam or joint.

SIDE BODY PANELS

The side body panel for ELANTRA is designed and stamped from a single piece of sheet metal in factory as shown in the figure. While the entire side panel is available for service, the partial panels sectioned by several damaged areas are also available. Therefore when repairing side body, refer to "Replacement parts section" of this manual to select and use the appropriate part.

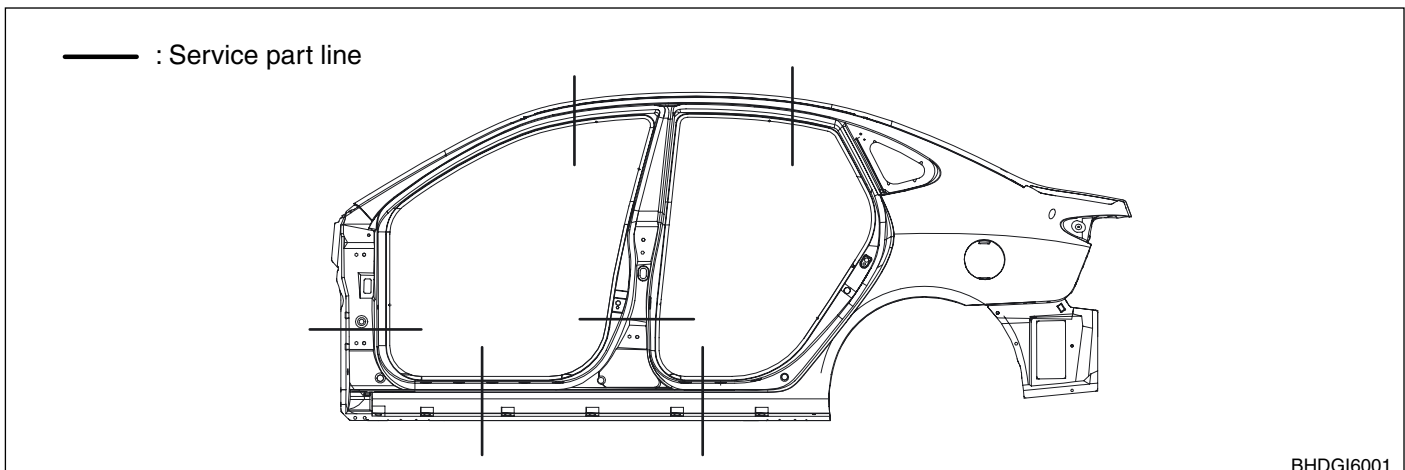

WELDING

All repairs in this manual require the use of a Metal-Inert Gas (MIG) welder, Gas (oxyacetylene) welding must not be used. Both high strength steel and mild steel can be welded using the MIG welder. The I-CAR recommendations for welding should be followed. The shielding gas should be 75% Argon and 25% CO₂.

The recommended welding wire size is 0.23" and the wire should satisfy the American Welding Society standard code AWSER70S-6.

During the repair process, plug welds are used to duplicate original factory spot welds. All plug welds should be done with the MIG welder. An 8 mm (5/16") hole is placed in the top (welding side) sheetmetal.

You then begin welding along the edges and the spiral towards the center (see illustration). This is important so that weld penetration between the two metal pieces takes place along the circumference of the circle.

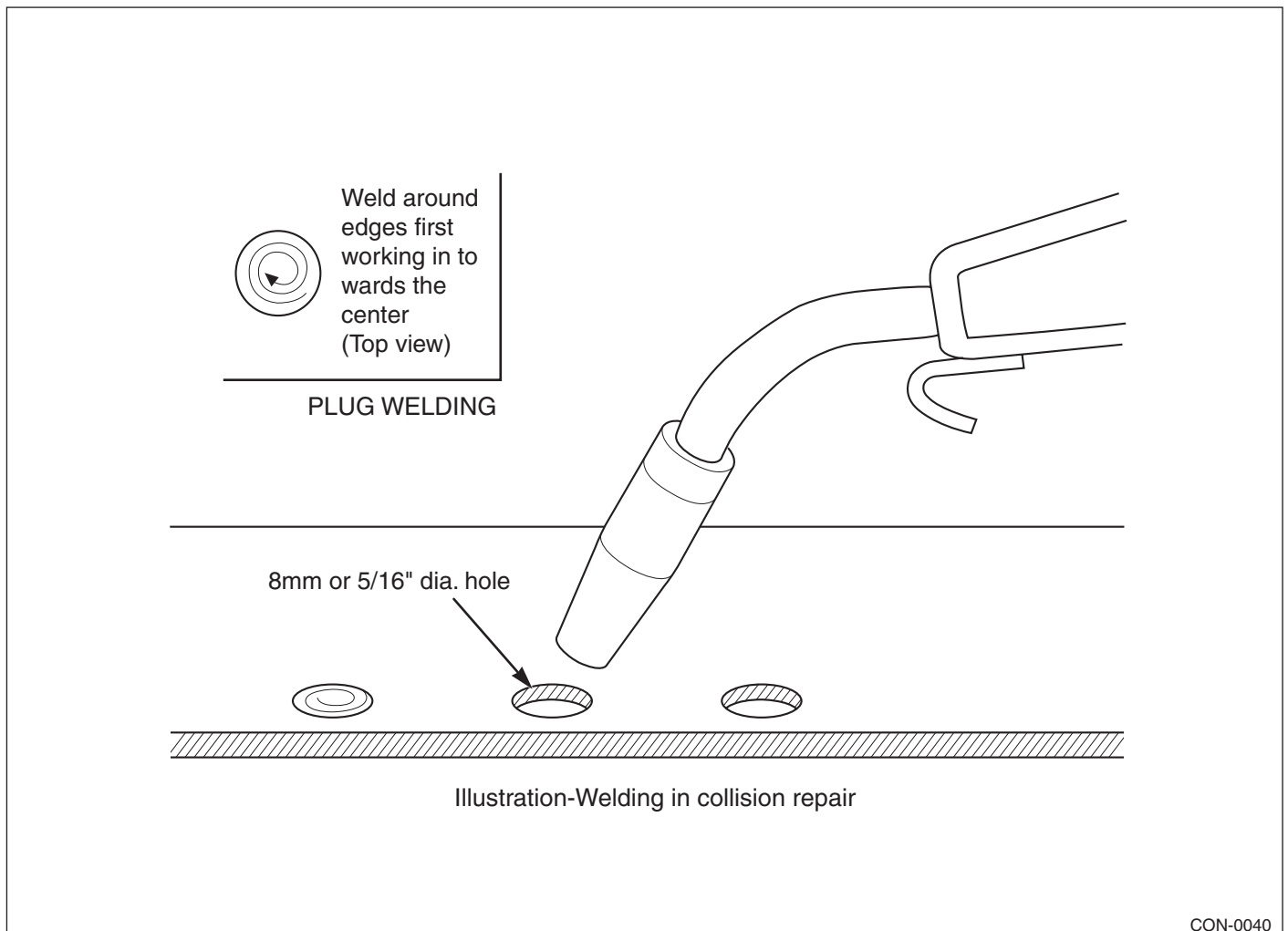

SAFETY FACTORS

Disconnect the negative(-) battery cable before performing any work on the vehicle.

Protect yourself by wearing goggles, earplugs, respirators, gloves, safety shoes, caps, etc. when working on a vehicle.

Safely support the vehicle before any work is done. Block the front or rear wheels if the vehicle is not lifted off of the ground.

Cap or remove the fuel tank when working on the rear section of the car.

Insure proper ventilation of your working area. Some paint and sealant can generate toxic gases when heated. Use an air chisel or saw to remove damaged panels instead of a gas torch.

Observe all local and national safety regulations when performing any work.

Cover interior with heat-resistant cover to insure safety when welding.

Take care when using gas or cutting torches so as not to burn body sealer or interior. Extinguish immediately if they should catch fire.

BODY CONSTRUCTION

FRONT & REAR BODY

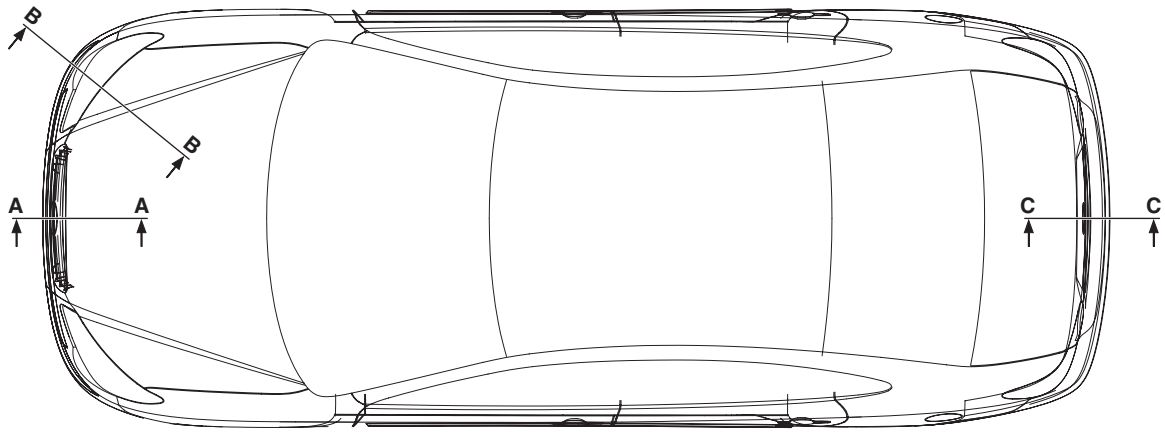

[TOP VIEW]

BHDBC6101

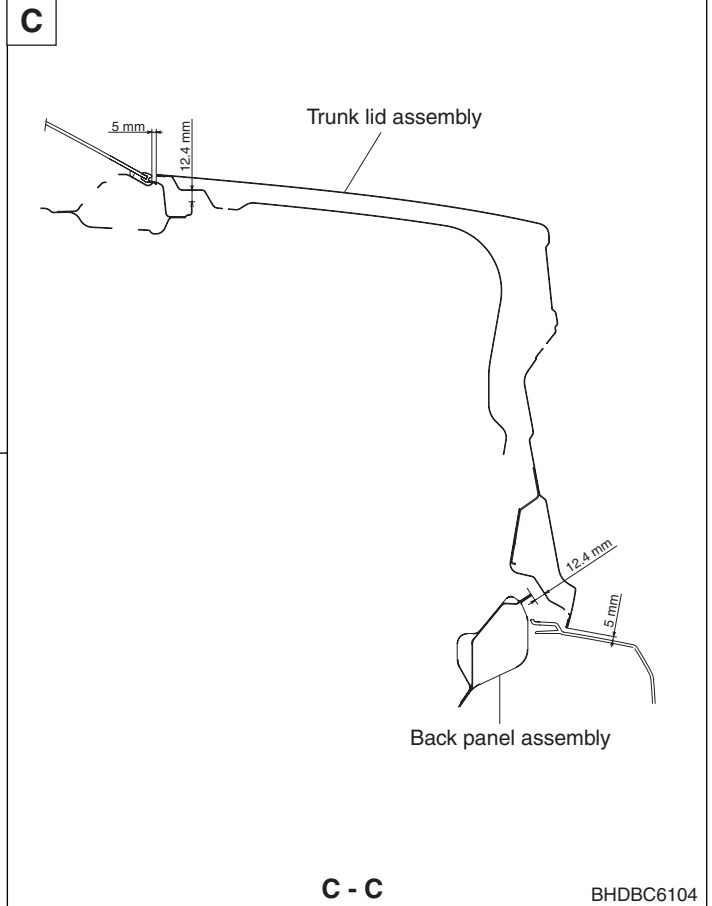
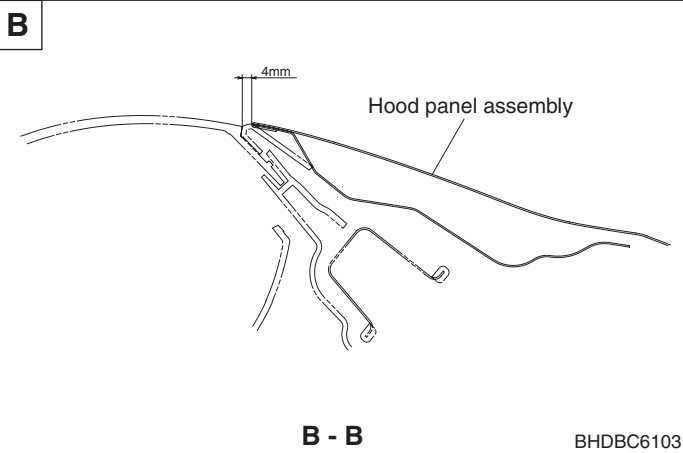
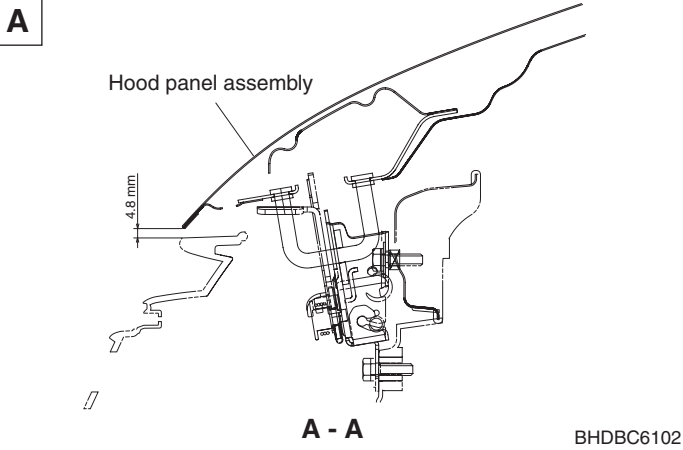

SIDE BODY

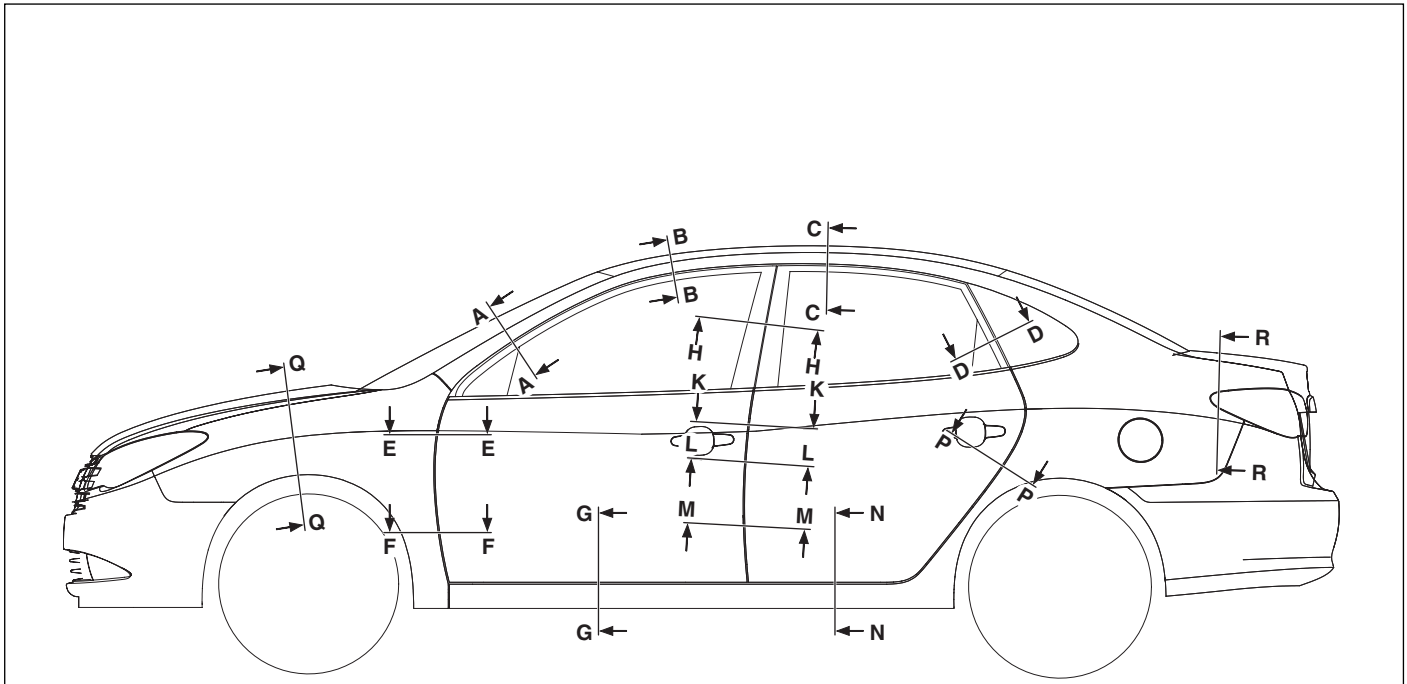

[SIDE VIEW]

BHDBC6201

