

# 2000 SERVICE MANUAL

## COMMERCIAL HUMMER®

### AM GENERAL CORPORATION

408 South Byrkit Avenue  
P.O. Box 728  
Mishawaka, Indiana 46546-0728

AM General Number 05745159  
Copyright ©1999  
All Rights Reserved. Printed in U.S.A.

### TABLE OF CONTENTS

General Information	1
Engine	2
Fuel, Emissions and Exhaust	3
Cooling System	4
Transmission/Transfer Case	5
Wheels and Tires/ Central Tire Inflation System	6
Brake System	7
Steering System	8
Axles/Suspension and Frame	9
Body	10
Heating/Ventilation/ Air Conditioning (HVAC)	11
Electrical	12
Accessories	13
Index	14



# Section 1 General Information, Lubrication and Maintenance

## TABLE OF CONTENTS

Abbreviations.....	1-12	Paint and Trim Colors.....	1-16
About This Manual.....	1-2	Recommended Fuel/Fluids/Lubricants/Capacities .....	1-24
Bolt Identification and Torque Limits (Dry*).....	1-13	Replacement Keys .....	1-16
Bolt Identification and Torque Limits (Wet*).....	1-14	Safety Certification Label.....	1-4
Carbon Monoxide .....	1-2	Safety Summary .....	1-1
Component Data .....	1-7	Scheduled Maintenance Chart.....	1-22
Emission Control information Label .....	1-3	Service Manual Comments .....	1-2
Engine Identification .....	1-5	Special Tools.....	1-34
EPA Noise Emission Control Information Label.....	1-5	Towing, Lifting, Jump Starting .....	1-17
Essential Tools .....	1-31	Transfer Case Identification.....	1-5
Fluid Capacities .....	1-10	Transmission Identification .....	1-4
Hummer Service Hotline .....	1-2	U.S./Metric Conversions and Equivalents .....	1-15
Lubrication and Maintenance Items.....	1-25	Vehicle Dimensions .....	1-11
Maintenance Schedule .....	1-21	Vehicle Identification Number (VIN) .....	1-5
Miscellaneous essential Tools .....	1-33	Vehicle Weights.....	1-10

## SAFETY SUMMARY

Individuals who decide to perform their own repairs should have proper training and limit repairs to components which will not affect the safety of the vehicle or its occupants.

When replacement parts are required, it is strongly recommended that they are purchased through an authorized HUMMER dealer. It is essential that replacement parts meet or exceed manufacturer’s specifications. Vehicle performance and personal safety may be impaired if other than original factory components are installed.

The installation of nonapproved accessories or conversions is not recommended as they could affect the vehicle’s driving characteristics and personal safety. AM General Corporation will not be liable for personal injury or damage to property resulting from the installation of nonapproved accessories or conversions to the HUMMER.

Following the safety precautions as prescribed throughout this manual may greatly reduce the risks of personal injury and damage to the vehicle. However, it is unlikely that AM General Corporation will account for all possibilities.

Warnings, cautions, and notes are used throughout this service manual to assist service personnel in the performance of maintenance actions. These statements are designed as reminders for trained and experienced service personnel.

**WARNINGS** — Indicate potential safety hazards and must be followed to avoid personal injury. Warnings appear as follows:

**WARNING:** *To avoid injury, do not remove surge tank filler cap before depressurizing cooling system when engine temperature is above 190° F (88° C).*

**CAUTIONS** — Indicate potential equipment damage, and must be followed to avoid damage to components or systems. An example of a caution is shown below:

**CAUTION:** To avoid starter damage, do not operate starter continuously for more than 15 seconds. Wait 10 to 15 seconds between periods of operation.

**NOTES** — Indicate methods or actions that may simplify vehicle maintenance or help maintain vehicle performance. An example of a note is shown below:

**NOTE:** Clean all components, examine for wear or damage, and replace if necessary.



### CARBON MONOXIDE

**WARNING:** *Carbon monoxide (exhaust gases) can be fatal.*

**WARNING:** *Brain damage or death can result from heavy exposure to carbon monoxide. The following precautions must be followed to ensure personal safety.*

1. Do not operate vehicle engine in enclosed areas. Do not idle the vehicle engine with vehicle windows closed. Be alert at all times for exhaust odors. Be alert for exhaust poisoning symptoms. They are:
  - Headache
  - Dizziness
  - Sleepiness
  - Loss of muscular control
2. If you see another person with exhaust poisoning symptoms:
  - Remove person from area
  - Expose to open air
  - Keep person warm
  - Do not permit physical exercise
  - Administer artificial respiration, if necessary
  - Notify medical personnel

The best defense against exhaust poisoning is adequate ventilation.

### ABOUT THIS MANUAL

This service manual contains instructions for maintaining the 1999 commercial HUMMER. Spend some time looking through this manual. Features to improve the usefulness of this manual and increase your efficiency are:

**Accessing Information** - These include: tabulated sections for quick reference, extensive troubleshooting guides for specific systems, and step-by-step directions for service repairs.

**Illustrations** - A variety of methods are used to make locating and repairing components easy. Locator illustrations, exploded views, and cut-away diagrams make the information in this manual easy to understand.

The service manual is the best source available for providing information and data critical to vehicle operation and maintenance. In this manual you will find the following information:

- Safety Summary
- General Information
- General Service Procedures
- Detailed Service Procedures
- Torque Ranges
- Wiring Diagrams and Schematics

HUMMER owners and dealership service personnel can submit service manual suggestions and comments in writing to:

AM General Corporation  
Commercial Publications Department  
408 S. Byrkit St.  
P.O. Box 728  
Mishawaka, IN 46546-0728

Forms are furnished at the end of this manual.

### Service Manual Revisions

In order to receive future revisions to this service manual, please write to:

AM General Corporation  
Service Parts Logistics Operations  
Commercial Publications/Customer Service  
408 South Byrkit Avenue  
P.O. Box 728  
Mishawaka, Indiana 46546-0728

**Be sure to specify publication number.**

### HUMMER SERVICE HOTLINE

On occasion, an unusual service problem can arise that is not covered in the manual. For this reason, AM General Corporation has established a service hotline for dealership assistance. The hotline number is: **1-800-638-8303**

### Transfer Case Hotline

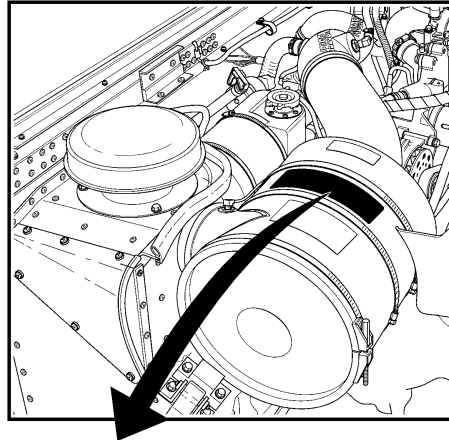
If you have questions that are not answered in Section 5 of this Service Manual, you can call the Transfer Case Hotline at **1-800-945-4327** (in the U.S.) for more information. International and Canadian customers and dealers should call **1-315-432-4110**.


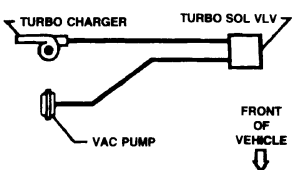


### EMISSION CONTROL INFORMATION LABEL

The vehicle emission control label contains engine information such as curb idle rpm, engine displacement, catalytic converter type, fuel rate, and vacuum hose routing.

This label is affixed to the air cleaner housing (Figure 1-1).



 001LRS	<b>LRS</b> 6.5 LITER XGMXH06.5521	<b>IMPORTANT ENGINE INFORMATION</b> General Motors Corporation	<b>CATALYST</b> OC		<b>LRS EMISSION HOSE ROUTING</b> 
	FUEL INJECTION TIMING & ENGINE IDLE SPEEDS ARE PRESET AT THE FACTORY. ADJUSTMENT DURING TUNE-UP IS NOT REQUIRED.	VALVE LASH	HYD.		
	SEE SERVICE MANUAL AND MAINTENANCE SCHEDULE FOR ADDITIONAL INFORMATION.	ADVERTISED HORSEPOWER	195 @ 3400 RPM		
<small>THIS ENGINE CONFORMS TO U.S. EPA AND CALIFORNIA REGULATIONS APPLICABLE TO 1999 MODEL-YEAR NEW HEAVY-DUTY DIESEL ENGINES. THIS ENGINE IS NOT CERTIFIED FOR USE IN AN URBAN BUS AS DEFINED AT 40 CFH 85.093-2. SALES OF THIS ENGINE FOR USE IN AN URBAN BUS IS A VIOLATION OF FEDERAL LAW UNDER THE CLEAN AIR ACT. THIS ENGINE IS CERTIFIED TO OPERATE ON CLEAN DIESEL FUEL OBD I CERTIFIED.</small>		FUEL RATE @ ADVER. HP	64.5 MM <sup>3</sup> / STROKE @ 3400 RPM		<small>PT. NO. 6010428 PRINTED IN U.S.A.</small>

00-OM1-002

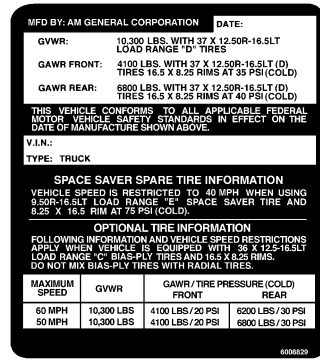
Figure 1-1: Emission Control Information Label Information



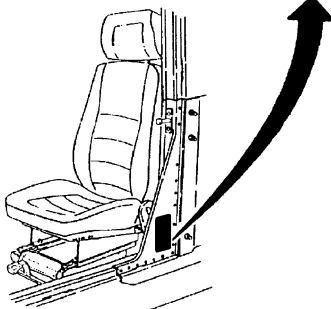
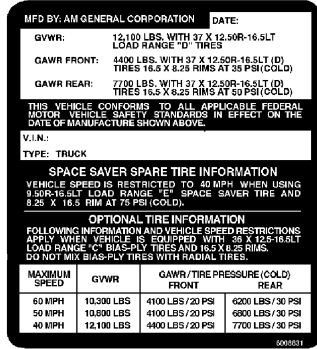
**SAFETY CERTIFICATION LABEL**

The safety certification label is located on the driver side B-pillar (door latch post) (Figures 1-2, 1-3, and 1-4). The label is required by the National Highway Traffic Safety Administration and includes a tamper-proof feature. If the label is tampered with, a void pattern will appear across the label.

The label contains the name of the manufacturer, the month and year the vehicle was manufactured, the certification statement, the vehicle identification number (VIN), and the vehicle model type. It also contains the Gross Vehicle Weight Rating (GVWR), Gross Axle Weight Ratings (GAWR), and wheel and tire information. For more information on the GVWR and GAWR, refer to “VEHICLE LOADING INFORMATION” in the Hummer Owner’s Manual.

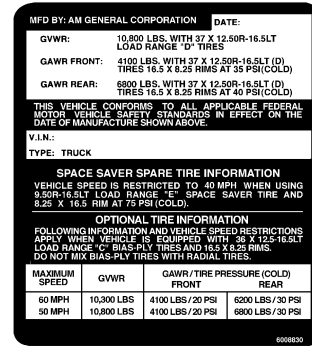


**Figure 1-3: Safety Certification Label for 10,300 lb GVWR Vehicles**



7-OM1-041

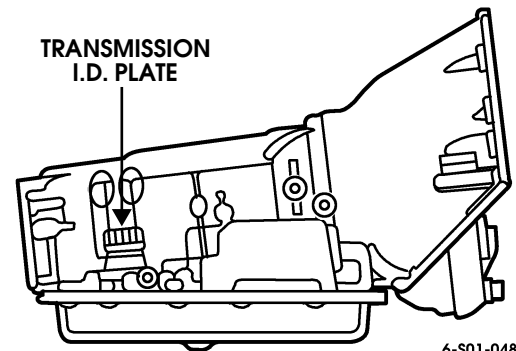
**Figure 1-2: Safety Certification Label for Fleet Vehicles (12,100 lb. GVW vehicles)**



**Figure 1-4: Safety Certification Label for 10,800 lb GVWR Vehicles**

**TRANSMISSION IDENTIFICATION**

The 4L80-E automatic transmission serial number is located on a plate at the right side of the transmission (Figure 1-5).



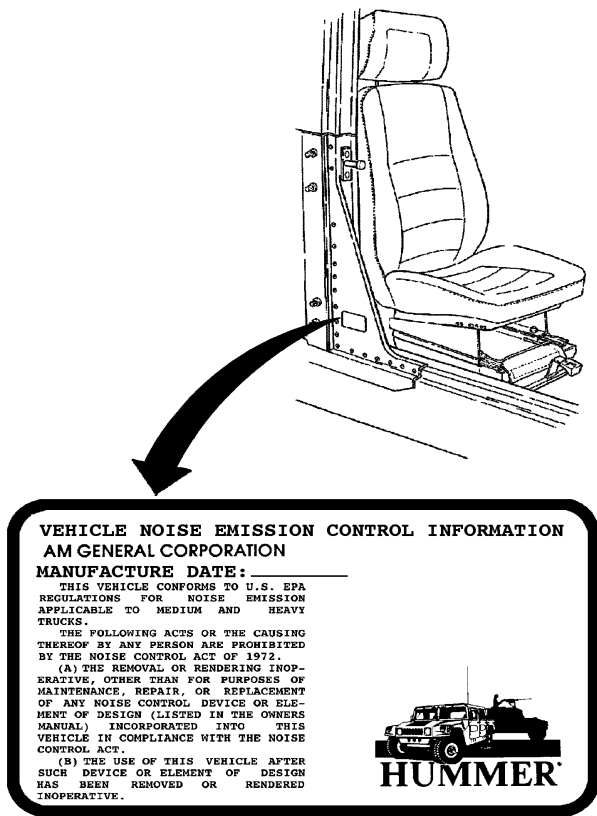
**Figure 1-5: Transmission I.D. Plate Location**



### EPA NOISE EMISSION CONTROL INFORMATION LABEL

The EPA noise emission control information label is located on the passenger side B-pillar (door latch post). The label is required by the EPA and includes a tamper-proof feature. If the label is tampered with, a void pattern will appear across the label. Notify the dealer or the manufacturer if the label is missing or displays a void pattern (Figure 1-6).

The label contains the name of the manufacturer, the month and year the vehicle was manufactured, a statement regarding vehicle conformance to applicable U.S. EPA regulations, and a description of acts prohibited by the Noise Control Act of 1972.

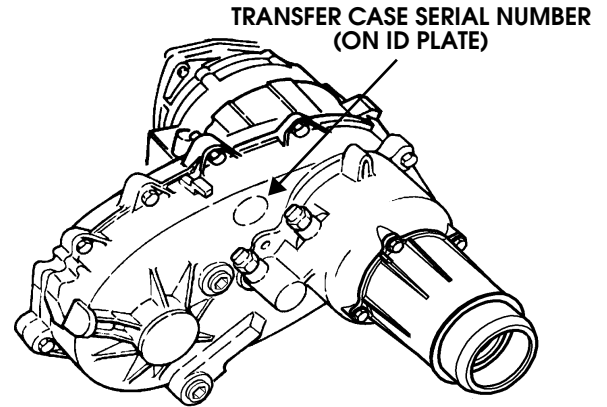


6-OM1-020

Figure 1-6: EPA Noise Emission Control Information Label Location

### TRANSFER CASE IDENTIFICATION

The transfer case serial and assembly numbers are located on a tag attached to the rear case (Figure 1-7).



9-OM5-002

Figure 1-7: Transfer Case I.D. Plate Location

### ENGINE IDENTIFICATION

The engine serial number label is located at the rear of the left cylinder head (Figure 1-8).

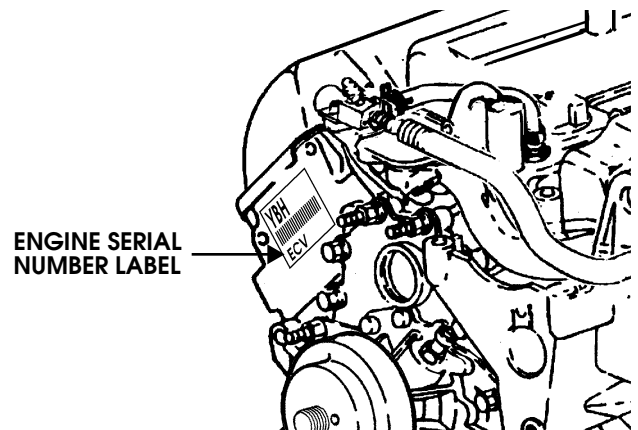
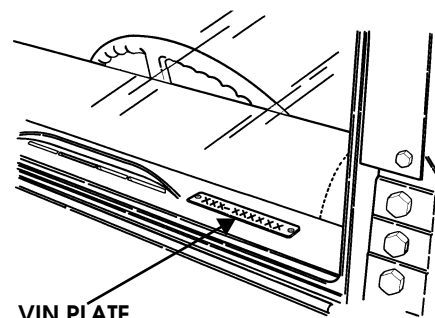


Figure 1-8: Engine I.D. Label Location

### VEHICLE IDENTIFICATION NUMBER (VIN)

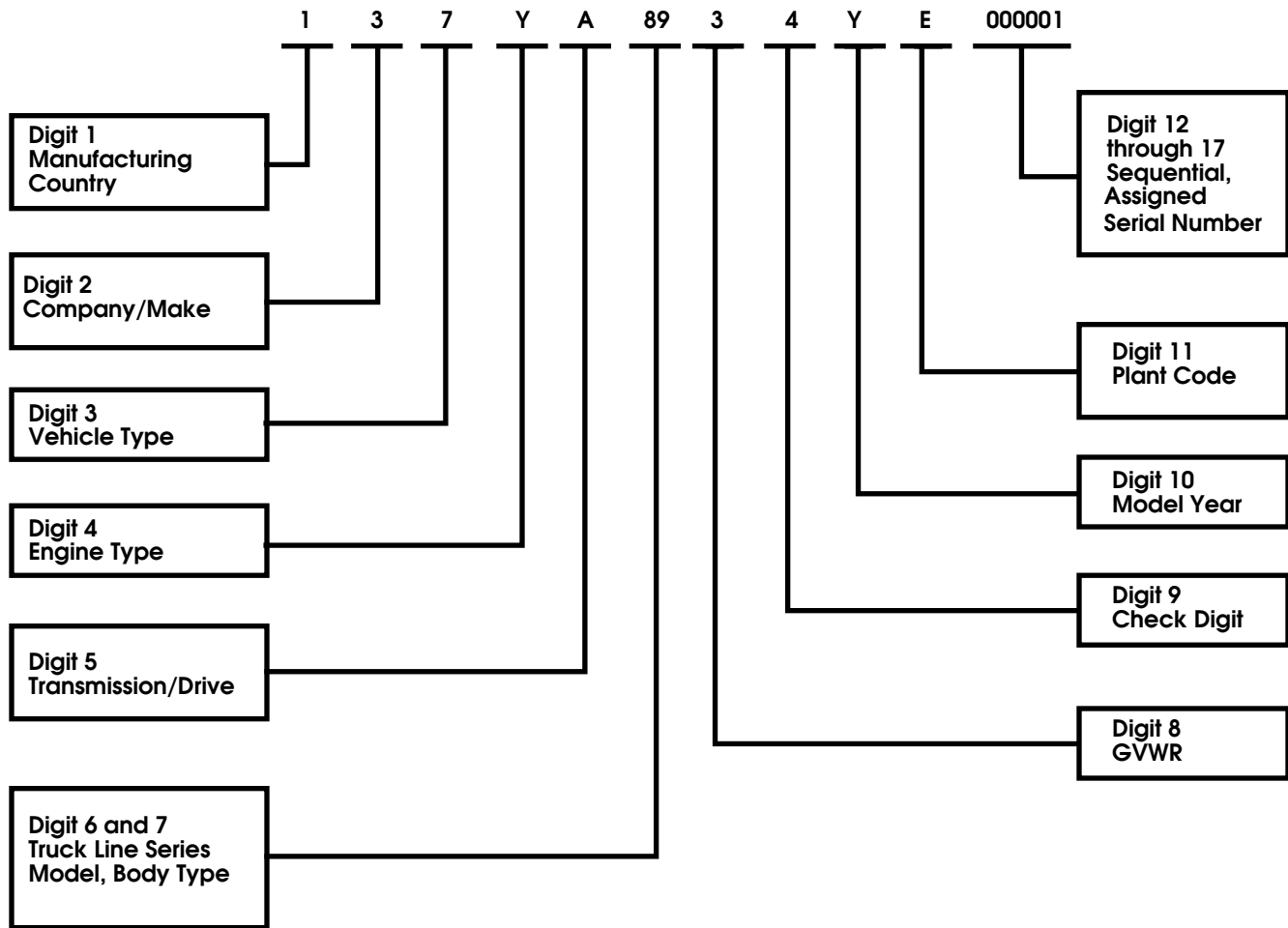
The VIN plate is located at the upper left front corner of the dashpad (Figure 1-9).



S01-006

Figure 1-9: VIN Plate Location

The first twelve digits of the seventeen digit VIN are explained in the chart on the following page.



**Vehicle Identification Number Decoding Chart**

Digit	Code	Code Definition
1	1	United States
2	3	AM General Corporation
3	7	Commercial Vehicles
	Z	6.5L (395 in. <sup>3</sup> ), Turbocharged Diesel, GM, 8 cyl., 195 hp
5	A	4-Speed, Automatic/LHD
6 & 7	83	1-1/4 ton 4-door Truck, utility – HMC4
	84	1-1/4 ton Station wagon Truck, utility – HMCS
	89	1-1/4 ton 2-door enlarged cab Truck, utility – XLC2
	90	1-1/4 ton Open body w/full hard doors Truck, utility – HMCO
8	3	Class 3, 10,001 lb - 14,000 lb (4,541 kg - 6,356 kg)
9	—	Check Digit
10	Y	2000
11	E	Mishawaka, Indiana
12-17	—	Sequential Serial Number



COMPONENT DATA

Engine:

Manufacturer ..... GM Powertrain
Model ..... 6.5 L (395 in.³)
Type..... Four Cycle, Turbocharged Diesel, Liquid-Cooled
Power Output: ..... 195 HP @ 3400 rpm/430 ft lb. Torque @ 1800 rpm

Engine Dimensions:

Length..... 35 in. (89 cm)
Width ..... 28 in. (71 cm)
Height ..... 28 in. (71 cm)
Net Weight, Dry ..... 701 lb (318 kg)

Governed Speed:

Full Load ..... 3,400 RPM
No Load..... 3,650 RPM
Idle Speed..... 700 RPM
Operating Speed ..... 1,500-2,600 RPM

Cylinders:

Number ..... 8
Arrangement..... 90° V
Firing Order..... 1-8-7-2-6-5-4-3 (Clockwise)
Bore ..... 4.06 in. (103.12 mm)
Stroke ..... 3.82 in. (9.7 cm)
Displacement ..... 6.5 L (395 in.³)
Compression Ratio: ..... 20.2:1

Lubricating System:

Type..... Pressure Feed
Operating Pressure:
(Minimum)..... 30 psi (206.8 kPa) @ 2000 RPM
(Idle Minimum)..... 6 psi (41.3 kPa)
System Capacity (Filter Included)..... 8 qt (7.6 L)
Operating Temperature (Normal)..... 180°-275° F (82°-135° C)
Oil Pump ..... High Output
Filter ..... Paper Element, Spin On

Fuel/Air System:

Fuel Supply Pump Type ..... Electronic
Fuel Filter Type ..... Two Stage Fuel Filter /Water Separator
Glow Plug Type ..... (11G) Fast Start

Starter:

Manufacturer .....Prestolite
Model .....MMO
Capacity (Peak) ..... 6.0 hp
Voltage ..... 12 V

Cooling System:

Type..... Liquid w/Fan and Radiator
Operating Temperature. .... 190°-235° F (88°-113° C)
Filler Cap Pressure ..... 15 psi (103 kPa)
Radiator Type..... 4 Row Core Downflow
Fan Type..... 8 Blade,suction w/viscous drive
Fan Diameter ..... 19.5 in. (49.5 cm)



# 1-8 General Information, Lubrication and Maintenance



## Thermostat:

Starts to Open ..... 190° F (88° C)  
Fully Open ..... 212° F (100° C)

## Generator:

Manufacturer ..... Delco  
Output ..... 124 AMP @ 1842 Engine RPM  
Rated Voltage ..... 13.35 -15.9 V

## Batteries:

Manufacturer ..... Johnson Controls  
Type ..... Low Maintenance  
Number ..... 2  
Voltage ..... 12 V  
Amperage  
    @ 0° F ..... 800 Cold Cranking amps Each Battery  
    32° F ..... 1000 Cold Cranking amps Each Battery  
    80° F ..... 110 Reserve Capacity (Minutes)

## Transmission:

Manufacturer ..... GM Powertrain  
Model ..... 4L80-E  
Type ..... 4-Speed, Automatic  
Converter Torque Ratio ..... 2.2:1  
Gear Ratios:  
    First ..... 2.48:1  
    Second ..... 1.48:1  
    Third ..... 1.00:1  
    Fourth ..... 0.75:1  
Reverse ..... 2.08:1  
Oil Type ..... Dexron® III  
Oil Pressure ..... 35-324 psi (241-2,234 kPa)

## Transfer Case:

Manufacturer ..... New Venture Gear  
Model ..... 242  
Type ..... Full Time Four-Wheel Drive  
Gear Ratios  
High and High Lock ..... 1:1  
Low Range ..... 2.72:1  
Oil Type ..... Dexron® III

## Geared Hub:

Manufacturer ..... AM General Corporation design, made by Tremec  
Type ..... Spur Gears  
Gear Ratio ..... 1.92:1  
Oil Type ..... SAE 80-90

## Axle/Differential:

Manufacturer ..... AM General Corporation design, made by Dana  
Type:  
    Axle ..... Fixed Mounted Differential W/ Independent Half Shafts  
    Differential ..... Hypoid Torque Biasing (Paired Worm Gears)  
Gear Ratio:  
    10,300 and 10,800: ..... 2.56:1  
    12,100: ..... 3.08:1



**Service Brake Caliper (Front):**

Manufacturer ..... Kelsey-Hayes  
Piston Diameter ..... 2.6 in. (6.6 cm)

**Service/Parking Brake Caliper (Rear):**

Manufacturer ..... Kelsey-Hayes  
Piston Diameter ..... 2.6 in. (6.6 cm)

**Service/Parking Brake Rotor:**

Manufacturer ..... Kelsey-Hayes  
Diameter ..... 10.5 in. (266.7 mm)  
Thickness ..... 0.87 in. (22 mm)  
Minimum Thickness ..... 0.81 in. (20.7 mm)

**Steering System:**

Steering Gear:

Manufacturer ..... Saginaw  
Type ..... Recirculating Ball, Worm and Nut  
Ratio ..... 13/16:1

Power Steering Pump:

Manufacturer ..... Saginaw  
Output Pressure (Max) ..... 1,465 - 1,515 psi (10,101 - 10,446 kPa)  
Flow Rate (Max) ..... 2.6 gpm (9.8 Lpm)  
Capacity (@ 1500 RPM) ..... 2.6 gpm (9.8 Lpm)  
Reservoir ..... Remote

Frame:

Manufacturer ..... AM General Corporation design, made by Dana  
Type ..... Steel Box  
No. of Crossmembers ..... 5

**Air Conditioner:**

Manufacturer (Compressor) ..... GM-Harrison  
Model ..... HD-6  
Field (Coil) ..... 12 V  
Oil Capacity ..... 8 fl oz (237 ml)  
Refrigerant ..... R-134a  
Capacity (system + 2 oz. of oil) ..... 3.2 lb. (1.45 kg)

**Winch:**

Manufacturer ..... Warn  
Model ..... 12,000 lb., 12VDC HUMMER  
Type ..... Electric Drive, Thermal Cutoff Switch  
Capacity ..... 12,000 lb (5,448 kg)

**Wheels and Tires:**

Manufacturer ..... Goodyear Tire Size 37 in. X 12.5R-16.5  
Wheel Type:  
Standard ..... One-Piece  
Size ..... 16.5 x 8.25 in.

# 1-10 General Information, Lubrication and Maintenance



## FLUID CAPACITIES

Cooling System .....	26 qt (25 L)
Engine:	
Crankcase (oil pan) only .....	7 qt (6.6 L)
Crankcase and Filter .....	8 qt (7.6 L)
Fuel Tank.....	25 gal. (95 L)
Auxiliary Fuel Tank .....	17 gal. (64.3 L)
Axle (front/rear) .....	2 qt (1.9 L)
Transmission:	
Drain and Refill (with Pan Removed) .....	7.7 qt (7.3 L)
W/Dry Converter .....	13.5 qt (12.8 L)
Transfer Case.....	3.5 qt (3.3 L)
Geared Hub.....	1 pt (0.47 L)
Steering System .....	1 qt (0.95 L)
Brake Hydraulic System (DOT 3)	
Master Cylinder .....	1.64 pt (0.78 L)
Total System .....	3.12 pt. (1.5 L)
Windshield Washer Reservoir .....	2.5 gal. (9.5 L)

## VEHICLE WEIGHTS

### Curb Weight (10,300/10,800 GVWR):

Two-Door Enlarged Cab (Hard Top) (XLC2) .....	6,460 lb (2,930 kg)
Four Door Open Top (w/ full doors) (HMCO) .....	6,710 lb (3,044 kg)
Four Door Hard Top (HMC4).....	6,860 lb (3,112 kg)
Four-Door Station Wagon (HMCS).....	7,050 lb (3,198 kg)

### Payload (10,300 GVWR):

Two-Door Enlarged Cab (Hard Top) (XLC2) .....	3,840 lb (1,742 kg)
Four-Door Open Top (w/ full doors) (HMCO).....	3,590 lb (1,628 kg)
Four Door Hard Top (HMC4).....	3,440 lb (1,560 kg)
Four-Door Station Wagon (HMCS).....	3,250 lb (1,474 kg)

### Payload (10,800 GVWR):

Two-Door Enlarged Cab (Hard Top) (XLC2) .....	4,340 lb (1,968 kg)
Four-Door Open Top (w/ full doors) (HMCO).....	4,090 lb (1,855 kg)
Four Door Hard Top (HMC4).....	3,940 lb (1,768 kg)
Four-Door Station Wagon (HMCS).....	3,750 lb (1,700 kg)

Gross Vehicle Weight (GVW) ..... 10,300 lb (4,676 kg)/10,800 lb (4,899 kg)

### Gross Axle Weight Rating (GAWR):

Front.....	4,100 lb (1,860 kg)
Rear.....	6,800 lb (3,084 kg)

Gross Combination Weight (GCW) ..... 14,800 lb (6,719 kg)

### Maximum Towed Load:

Two-Door Enlarged Cab (Hard Top) (XLC2) .....	8,340 lb (3,783 kg)
Four-Door Open Top (w/ full doors) (HMCO).....	8,090 lb (3,670 kg)
Four-Door Hard Top (HMC4).....	7,940 lb (3,602 kg)
Four-Door Station Wagon (HMCS).....	7,750 lb (3,515 kg)



**Turbo Diesel Engine -- (12,100 lb. (5,489 kg) GVWR Vehicles -- Fleet Vehicles Only**

Curb Weight (12,100 GVWR):

Two-Door Enlarged Cab (Hard Top) (XLC2) .....	6,720 lb (3,048 kg)
Four Door Hard Top (HMC4).....	7,120 lb (3,230 kg)
Four-Door Station Wagon (HMCS).....	7,310 lb (3,316 kg)

Payload (12,100 GVWR):

Two-Door Enlarged Cab (Hard Top) (XLC2) .....	5,380 lb (2,440 kg)
Four Door Hard Top (HMC4).....	4,980 lb (2,258 kg)
Four-Door Station Wagon (HMCS).....	4,790 lb (2,172 kg)

Gross Vehicle Weight (GVW) ..... 12,100 lb (5,488 kg)

Gross Axle Weight Rating (GAWR):

Front .....	4,400 lb (1,995 kg)
Rear .....	7,700 lb (3,492 kg)

Gross Combination Weight (GCW) ..... 16,500 lb (6,719 kg)

Maximum Towed Load:

Two-Door Enlarged Cab (Hard Top) (XLC2) .....	9,780 lb (4,436 kg)
Four-Door Hard Top (HMC4) .....	9,380 lb (4,254 kg)
Four-Door Station Wagon (HMCS).....	9,190 lb (4,168 kg)

**VEHICLE DIMENSIONS**

Length (see Note)184.5 in. (4,686 mm):

Height .....	75 in. (190.5 mm)
Width (without mirrors) .....	86.50 in. (219.7 mm)
Ground Clearance .....	16 in. (41 cm) (at GVW)
Wheelbase .....	130 in (330 cm)
Track Width .....	72 in. (183 m)

**NOTE:** The vehicle weight and dimensions data applies to models without a winch.



## ABBREVIATIONS

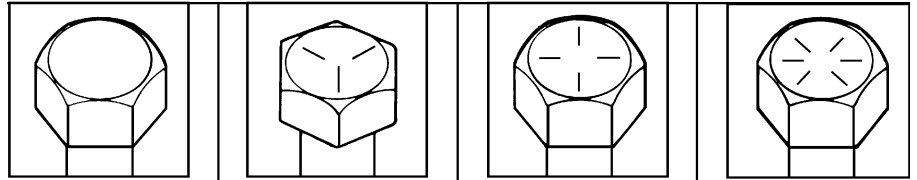
ABS	Antilock Brake System	lh	Left Hand
A/C	Air Conditioning	L	Liter
a.c.	Alternating Current	max	Maximum
AMP	Ampere	m	Meter
CO	Carbon Monoxide	mpg	Miles Per Gallon
C	Celsius (centigrade)	mph	Miles Per Hour
cm	Centimeter	mm	Millimeter
CTIS	Central Tire Inflation System	min	Minimum
CDR	Crankcase Depression Regulator	-	Minus
cm <sup>3</sup>	Cubic Centimeter	-	Negative
in. <sup>3</sup>	Cubic Inch	No	Number
cyl.	Cylinder	Ohm	Ohms
°	Degree (angle or temperature)	oz	Ounce
DTC	Diagnostic Trouble Code	O.D.	Outside Diameter
dia	Diameter	P/N	Part Number
d.c.	Direct Current	%	Percentage
EPA	Environmental Protection Agency	pt	Pint
F	Fahrenheit	+	Plus
ft	Feet	+	Positive
ft/min	Feet Per Minute	lb	Pound
fl oz	Fluid Ounce	lb-ft.	Pound-feet
gal	Gallon	lb-in.	Pound-inch
g	Gram	psi	Pounds Per Square Inch
GAWR	Gross Axle Weight Rating	qt.	Quart
GVW	Gross Vehicle Weight	:	Ratio
GVWR	Gross Vehicle Weight Rating	ref.	Reference
hp	Horsepower	RPM	Revolutions Per Minute
HVAC	Heat, Ventilation, and Air Conditioning	rh	Right-Hand
in.	Inch	cm <sup>2</sup>	Square Centimeters
INC.	Include	in <sup>2</sup>	Square Inches
ID	Identification	TT4	Torque Trac 4
I.D.	Internal Diameter	VIN	Vehicle Identification Number
kg	Kilograms	V	Volts
km	Kilometer	W	Watts
km/h	Kilometers Per Hour	UNC	Unified Coarse
kPa	Kilopascals	UNF	Unified Fine



**BOLT IDENTIFICATION AND TORQUE LIMITS (DRY\*)**

\* A phosphate and oil bolt is considered dry

**Bolt Head ID Marks and SAE GRADE**



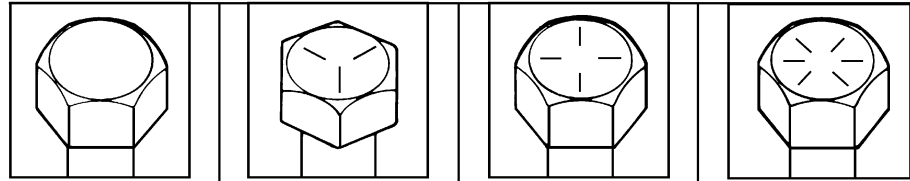
BOLT SIZE			SAE GRADE NO. 1 OR 2	SAE GRADE NO. 5	SAE GRADE NO. 6 OR 7	SAE GRADE NO. 8
DIA. INCHES	MILLI-METERS	THREADS PER INCH	POUND FEET (NEWTON-METERS)	POUND FEET (NEWTON-METERS)	POUND FEET (NEWTON-METERS)	POUND FEET (NEWTON-METERS)
1/4	6	20	5(7)	8(11)	10(14)	12(16)
1/4	6	28	6(8)	10(14)	---	14(19)
5/16	8	18	11(15)	17(23)	19(26)	24(33)
5/16	8	24	13(18)	19(26)	---	27(37)
3/8	10	16	18(24)	31(42)	34(46)	44(60)
3/8	10	24	20(27)	35(47)	---	49(66)
7/16	11	14	28(38)	49(66)	55(75)	70(95)
7/16	11	20	30(41)	55(75)	---	78(106)
1/2	13	13	39(53)	75(102)	85(115)	105(142)
1/2	13	20	41(56)	85(115)	---	120(163)
9/16	14	12	51(69)	110(149)	120(163)	155(210)
9/16	14	18	55(75)	120(163)	---	170(231)
5/8	16	11	63(85)	150(203)	167(226)	210(285)
5/8	16	18	95(129)	170(231)	---	240(325)
3/4	19	10	105(142)	270(366)	280(380)	375(509)
3/4	19	16	115(156)	295(400)	---	420(570)
7/8	22	9	160(217)	395(536)	440(597)	605(820)
7/8	22	14	175(237)	435(590)	---	675(915)
1	25	8	235(319)	590(800)	660(895)	910(1234)
1	25	14	250(339)	660(895)	---	990(1342)
1-1/8	29	---	---	800 - 880 (1085 - 1193)	---	1280 - 1440 (1736 - 1953)
1-1/4	32	---	---	---	---	1820 - 2000 (2468 - 2712)
1-3/8	35	---	---	1460 - 1680 (1980 - 2278)	---	2380 - 2720 (3227 - 3688)
1-1/2	38	---	---	1940 - 2200 (2631 - 2983)	---	3160 - 3560 (4285 - 4827)



**BOLT IDENTIFICATION AND TORQUE LIMITS (WET\*)**

\*A cadmium plated bolt is considered wet.

**Bolt Head ID Marks and SAE Grade**



BOLT SIZE			SAE GRADE NO. 1 OR 2	SAE GRADE NO. 5	SAE GRADE NO. 6 OR 7	SAE GRADE NO. 8
DIA. INCHES	MILLI-METERS	THREADS PER INCH	POUND FEET (NEWTON-METERS)	POUND FEET (NEWTON-METERS)	POUND FEET (NEWTON-METERS)	POUND FEET (NEWTON-METERS)
1/4	6	20	4(5)	7(10)	9(12)	11(15)
1/4	6	28	5(7)	9(12)	—	13(17)
5/16	8	18	10(14)	15(20)	17(23)	22(30)
5/16	8	24	12(16)	17(23)	—	24(33)
3/8	10	16	16(22)	28(38)	31(42)	40(54)
3/8	10	24	18(24)	32(43)	—	44(60)
7/16	11	14	25(34)	44(60)	50(68)	63(85)
7/16	11	20	27(37)	50(68)	—	70(95)
1/2	13	13	35(48)	68(92)	77(104)	95(129)
1/2	13	20	37(50)	77(104)	—	108(146)
9/16	14	12	46(62)	99(134)	108(146)	140(190)
9/16	14	18	50(67)	108(146)	—	153(207)
5/8	16	11	57(77)	135(183)	150(203)	189(256)
5/8	16	18	85(115)	153(207)	—	216(293)
3/4	19	10	95(129)	243(330)	252(342)	338(458)
3/4	19	16	104(141)	266(361)	—	378(513)
7/8	22	9	144(195)	356(483)	396(537)	545(739)
7/8	22	14	158(214)	392(532)	—	608(824)
1	25	8	212(287)	531(720)	594(805)	819(1111)
1	25	14	225(305)	594(805)	—	891(1208)
1-1/8	29	—	—	720 - 792 (976 - 1074)	—	1152 - 1296 (1562 - 1757)
1-1/4	32	—	—	—	—	1638 - 1800 (2221 - 2441)
1-3/8	35	—	—	1314 - 1512 (1782 - 2050)	—	—
1-1/2	39	—	—	1746 - 1980 (2368 - 2685)	—	2844 - 3204 (3857 - 4345)



U.S./METRIC CONVERSIONS AND EQUIVALENTS

Metric Conversions

<u>MULTIPLY</u>	<u>BY</u>	<u>TO GET</u>
INCHES	2.54	CENTIMETERS
FEET	0.305	METERS
MILES	1.609	KILOMETERS
SQUARE INCHES	6.451	SQUARE CENTIMETERS
CUBIC INCHES	16.39	CUBIC CENTIMETERS
FLUID OUNCES	29.573	MILLILITERS
PINTS	0.473	LITERS
QUARTS	0.946	LITERS
GALLON	3.785	LITERS
POUNDS	0.454	KILOGRAMS
SHORT TONS	0.907	METRIC TONS
POUND-INCHES	0.113	NEWTON-METERS
POUND-FEET	1.356	NEWTON-METERS
POUNDS PER SQUARE INCH	6.895	KILOPASCALS
MILES PER GALLON	0.425	KILOMETERS PER LITER
MILES PER HOUR	1.609	KILOMETERS PER HOUR

U.S. Standard Conversions

<u>MULTIPLY</u>	<u>BY</u>	<u>TO GET</u>
CENTIMETERS/MILLIMETERS	0.3937	INCHES
METERS	3.280	FEET
KILOMETERS	0.621	MILES
SQUARE CENTIMETERS	0.155	SQUARE INCHES
CUBIC CENTIMETERS	0.061	CUBIC INCHES
MILLILITERS	0.034	FLUID OUNCES
LITERS	2.113	PINTS
LITERS	1.057	QUARTS
LITERS	0.264	GALLONS
KILOGRAMS	2.205	POUNDS
METRIC TONS	1.102	SHORT TONS
NEWTON-METERS	0.738	POUND-FEET
NEWTON-METERS	8.851	POUND-INCHES
KILOPASCALS	0.145	POUNDS PER SQUARE INCH
	KILOMETERS PER LITER	2.354MILES PER GALLON
	KILOMETERS PER HOUR	0.621MILES PER HOUR

Temperature

32° FAHRENHEIT = 0° CELSIUS  
 CELSIUS = 0.556 X (F° -32)

212° FAHRENHEIT = 100° CELSIUS  
 FAHRENHEIT = (1.8 X C°) +32





## PAINT AND TRIM COLORS

Interior trim colors are tan and gray. Seating materials are available in cloth and vinyl.

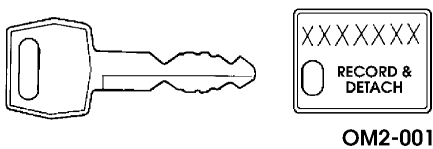
Soft top colors and codes are: Tan (T) and Black (B).

Exterior paint colors and codes are outlined in the following chart.

Top Coat Description	AM General Code
Candy Apple Red	R19
White Gloss	W8
Black Gloss	B9
Competition Yellow	Y20
Burgundy Metallic	P17
Bright White	W14
Silver Metallic	S15
Mesa Dusk Carmel	C22
Metallic Pewter	P33
Woodland Green	G23

## REPLACEMENT KEYS

Replacement keys can be cut using Briggs and Stratton or Curtis key cutting tools. Key codes are provided on an identification tag included with each key set (Figure 1-10).



**Figure 1-10: Key Code Location**



## TOWING, LIFTING, JUMP STARTING

### Vehicle Lifting/Jacking Points

Vehicle jacking points are shown in Figure 1-11. The vehicle can be raised with a floor jack at any of the indicated positions. Jacking can be performed at the front, rear, or at any one wheel.

In cases where the entire vehicle must be raised, use jack stands at equidistant points on the frame rails. Use a minimum of four stands to support the vehicle. Suggested capacity for individual jack stands is 3 ton, with a vertical reach of 19 in. (49 cm).

Typical jack stand placement for raising one side of the vehicle is shown in Figure 1-12. Always be sure the jack stand saddle is securely engaged and the stand is level.

### Vehicle Hoisting

Hummer vehicles can be raised on a hoist for service access. Drive-on and swivel arm hoists are both acceptable. Hoist capacity and width are important. The greater width and weight of Hummer vehicles require a larger hoisting platform. Do not use an under capacity hoist, or modify an existing hoist for use; this practice is neither safe nor recommended.

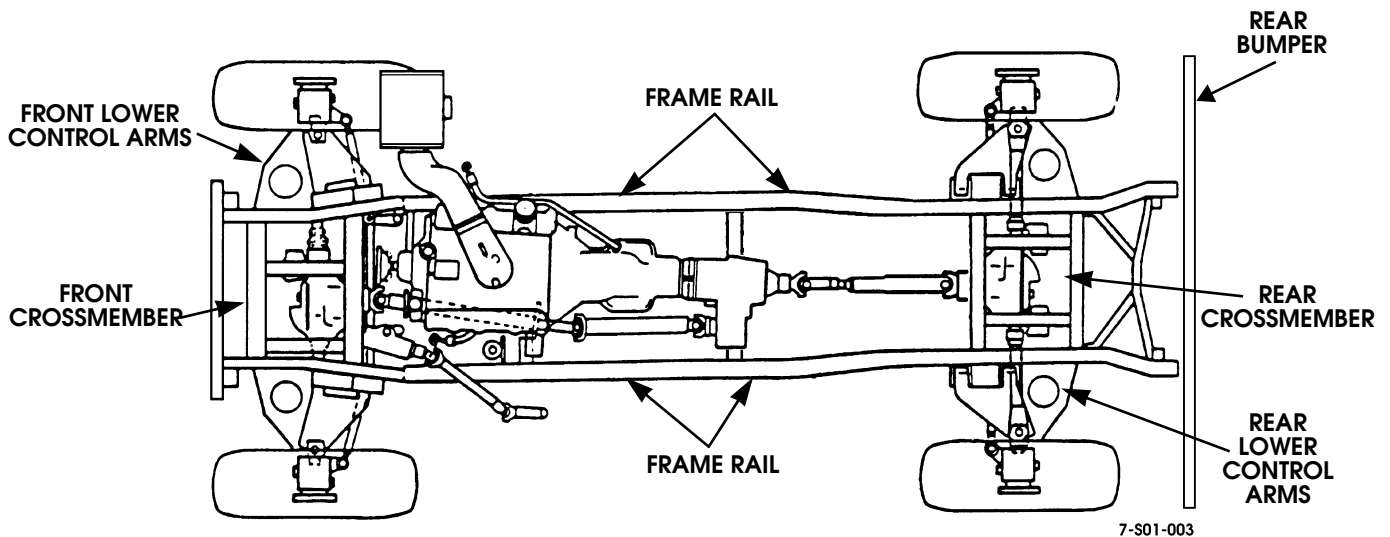


Figure 1-11: Vehicle Jacking Points

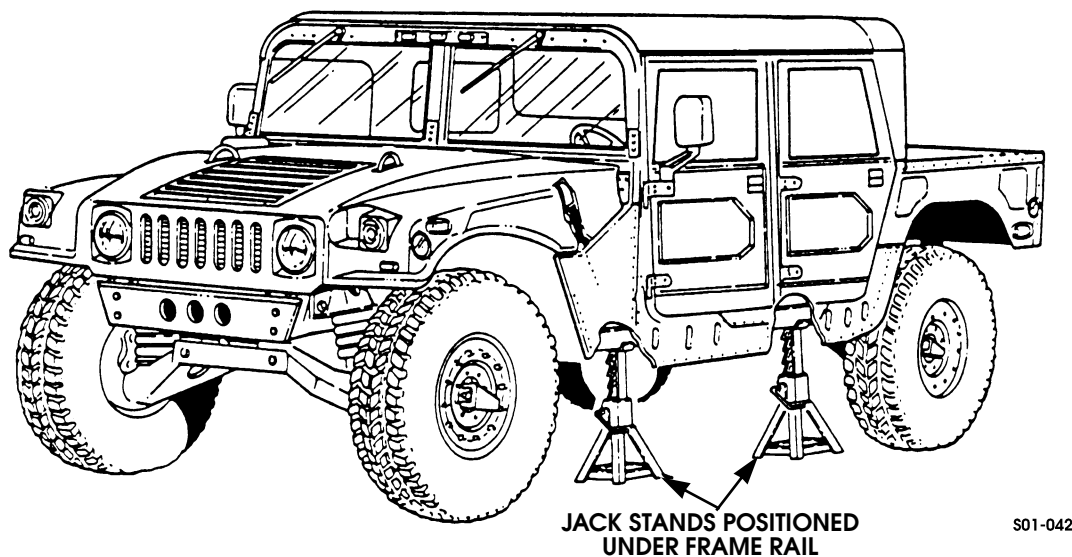


Figure 1-12: Typical Jack Stand Placement



### Towing Recommendations

Hummer vehicles can be towed with wheel lift, sling-type, or flat bed tow equipment.

Flat bed and wheel lift equipment is recommended over sling type or A-frame equipment.

#### Towing Cautions:

- Remove or secure loads in the towed vehicle
- Never use the shackles on the front bumpers as tie down points
- Always use safety chains on sling towed vehicles
- Always follow the transmission/transfer case shift position recommendations (Transfer Case in N (Neutral); Transmission in P (Park)).
- Use a low vehicle trailer for recreational towing (behind an RV or other vehicle) when possible.
- Never put chains, cables or straps on any steering components.

### Flat Bed/Wheel Lift Towing Procedures

Flat bed/wheel lift tow vehicles are highly recommended. They keep all of the towed vehicle wheels off the pavement. This is important with full time four wheel drive vehicles.

Loading only requires that the towed vehicle be raised or winched onto the towing platform. A further advantage of this type equipment is that tow speed and distance are not limited. Once the towed vehicle is loaded, set the parking brake, shift the transmission into Park and install the vehicle tie downs. Tie down attachment points are shown in Figure 1-13.

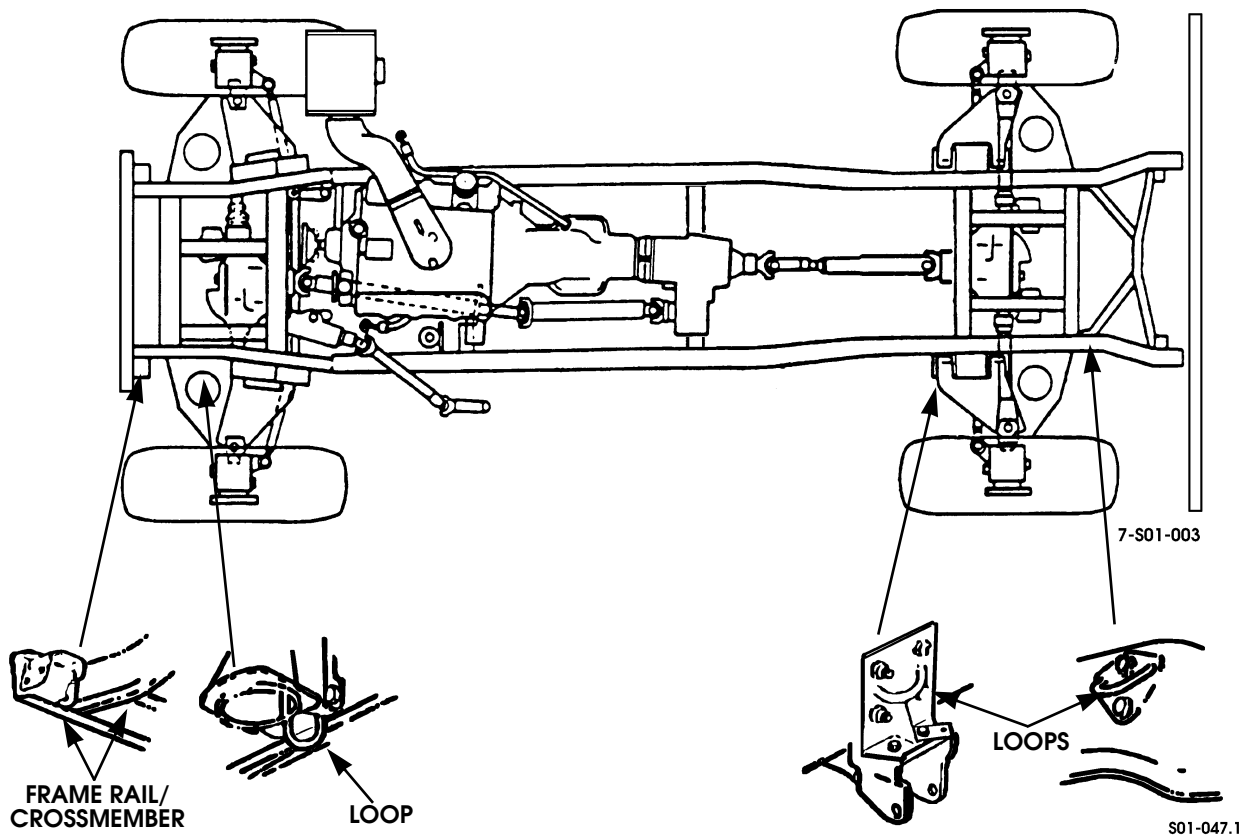


Figure 1-13: Vehicle Tie-Down Points



## Conventional Towing Procedures

### Front Towing

1. Loop chains around lower control arms and secure to tow sling (Figure 1-14).
2. Insert 4" x 4" x 48" length of wood between bumper and sling chains (Figure 1-14).
3. Raise front end and verify that sling is firmly positioned against front bumper.
4. Release parking brakes.
5. Shift transmission into Park and transfer case into Neutral.
6. Position tow dollies under rear wheels. Proceed with towing operations.

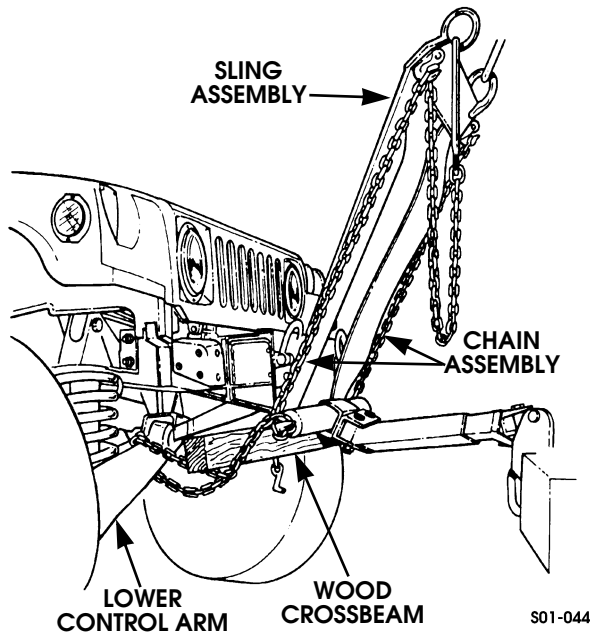


Figure 1-14: Front Towing With Conventional Equipment

### Rear Towing

1. Loop sling chain around frame rails adjacent to rear crossmember and secure to tow sling (Figure 1-15).
2. Insert 4" x 4" x 48" length of wood between bumper and sling chains (Figure 1-15).
3. Raise rear end and verify that sling is firmly positioned against rear bumper.
4. Release parking brakes.
5. Shift transmission into Park and transfer case into Neutral.
6. Position tow dollies under front wheels. Proceed with towing operations.

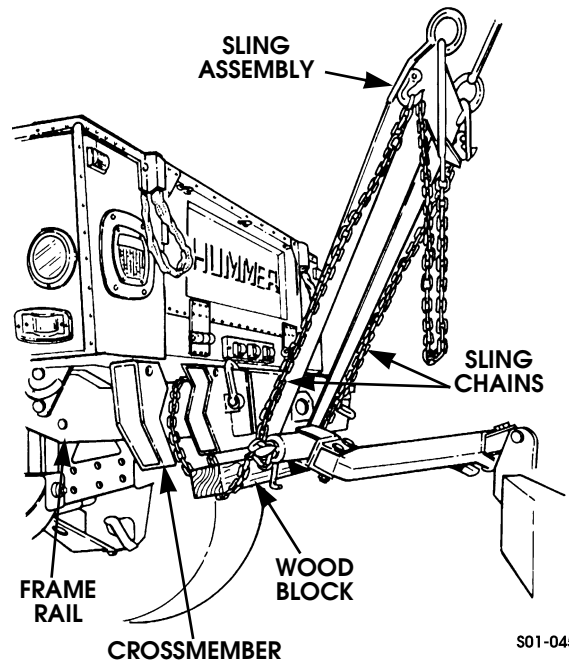


Figure 1-15: Rear Towing with Conventional Equipment

### Conventional Towing When Keys are not Available

If the vehicle doors are locked and the keys are not available you cannot determine that the transmission is in Park and the transfer case is in "N" (Neutral). In these situations, you must use one of the following towing methods:

- a. Use tow dollies at all wheels and flat tow,
- or**
- b. Raise the vehicle front or rear and use tow dollies under the wheels not raised.

### Recreational Towing

Hummer vehicles can be towed behind an RV if desired. A low-boy style vehicle trailer is best for this purpose. Flat towing is not recommended.