

# 2011-2013 Odyssey Body Repair Manual

## INTRODUCTION

### How to Use This Manual

This manual covers the repairs of a 2011-2013 model-series Odyssey that has been involved in a collision, and it describes the work related to the replacement of damaged body parts. Please read through these instructions and familiarize yourself with them before actually using this manual.

NOTE: Refer to the appropriate Odyssey Service Manual for specifications, wire harness locations, safety stand support points, etc.

### Special Information

#### **⚠ WARNING**

You CAN be KILLED or SERIOUSLY HURT if you don't follow instructions.

#### **⚠ CAUTION**

You CAN be HURT if you don't follow instructions.

NOTE: Gives helpful information.

#### **⚠ CAUTION**

Detailed descriptions of standard workshop procedures, safety principles and service operations are not included. Please note that this manual does contain warnings and cautions against some specific service methods which could cause PERSONAL INJURY, damage a vehicle, or make it unsafe. Please understand that these warnings cannot cover all conceivable ways in which service, whether or not recommended by Honda, might be done or of the possible hazardous consequences of each conceivable way, nor could Honda investigate all such ways. Anyone using service procedures or tools, whether or not recommended by Honda, must satisfy himself thoroughly that neither personal safety or vehicle safety will be jeopardized.

All information contained in this manual is based on the latest product information available at the time of printing. We reserve the right to make changes at any time without notice. No part of this publication may be reproduced, stored in retrieval system, or transmitted, in any form by any means, electronic, mechanical, photocopying, recording, or otherwise, without the prior written permission of the publisher. This includes text, figures and tables.

Honda Motor Co., Ltd.  
Customer Service Technology  
Development Division

**1** General Information

**2** Paint Information

**3** \*Replacement

**4** Body Dimensional Drawings

**5** Rust Prevention

General Safety Precautions

Reference

Sections with an \* include SRS components; special caution is required when servicing.

# A Few Words About Safety

## Service Information

The repair information contained in this manual is intended for use by qualified, professional technicians. Attempting repairs without the proper training, tools, and equipment could cause injury to you or others. It could also damage the vehicle or create an unsafe condition.

This manual describes the proper methods and procedures for doing repairs. Some procedures require the use of specially designed tools and dedicated equipment. Any person who intends to use a replacement part, a repair procedure, or a tool that is not recommended by Honda, must determine the risks to their personal safety and the safe operation of the vehicle.

If you need to replace a part, use Honda parts with the correct part number, or an equivalent part. We strongly recommend that you do not use replacement parts of inferior quality.

### FOR YOUR CUSTOMER'S SAFETY

Proper repair is essential to the customer's safety and the reliability of the vehicle. Any error or oversight while repairing a vehicle can result in faulty operation, damage to the vehicle, or injury to others.

#### **WARNING**

Improper repairs can create an unsafe condition that can cause your customer or others to be seriously hurt or killed.

Follow the procedures and precautions in this manual and other service materials carefully.

### FOR YOUR SAFETY

Because this manual is intended for the professional service technician, we do not provide warnings about many basic shop safety practices (for example, hot part - wear gloves). If you have not received shop safety training or do not feel confident about your knowledge of safe repairing practices, we recommend that you do not attempt to do the procedures described in this manual.

#### **WARNING**

Failure to properly follow instructions and precautions can cause you to be seriously hurt or killed.

Follow the procedures and precautions in this manual carefully.

Some of the most important general service safety precautions are given below. However, we cannot warn you of every conceivable hazard that can arise in doing repair procedures. Only you can decide whether or not you should do a given task.

### IMPORTANT SAFETY PRECAUTIONS

- Make sure you have a clear understanding of all basic shop safety practices and that you are wearing appropriate clothing and using safety equipment. When doing any repair task, follow these precautions:
  - Read all of the instructions before you begin, and make sure you have the tools, the replacement or repair parts, and the skills required to do the tasks safely and completely.
  - Protect your eyes by using proper safety glasses, goggles, or face shields any time you hammer, drill, grind, or work around pressurized air or liquids and springs or other stored-energy components. If there is any doubt, put on eye protection.
  - Use other protective wear when necessary, for example, gloves or safety shoes. Handling hot or sharp parts can cause severe burns or cuts. Before you grab something that looks like it can hurt you, stop and put on gloves.
  - Protect yourself and others whenever you have the vehicle up in the air. Any time you raise the vehicle, either with a lift or a jack, make sure that it is always securely supported. Use jack stands.
  - Protect yourself by wearing an approved welding helmet, gloves, and safety shoes any time you are welding. Protect yourself from burns from hot parts; allow the parts to cool before working in that area.
  - Protect yourself from paints and harmful chemicals by wearing an approved respirator, eye protection, and gloves whenever you are painting. Spray paint only in an approved paint booth that is well ventilated.

# Introduction

---

## Special Information

### How to Use This Manual

This manual covers the repairs of a 2011 model-series Odyssey that has been involved in a collision, and it describes the work related to the replacement of damaged body parts.  
Please read through these instructions and familiarize yourself with them before actually using this manual.  
NOTE: Refer to the appropriate Odyssey Service Manual for specifications, wire harness locations, safety stand support points, etc.

### Special Information

#### **⚠ WARNING**

You CAN be KILLED or SERIOUSLY HURT if you don't follow instructions.

#### **⚠ CAUTION**

You CAN be HURT if you don't follow instructions.

NOTE: Gives helpful information.

#### **⚠ CAUTION**

Detailed descriptions of standard workshop procedures, safety principles, and service operations are not included. Please note that this manual does contain warnings and cautions against some specific service methods which could cause PERSONAL INJURY, damage a vehicle, or make it unsafe. Please understand that these warnings cannot cover all conceivable ways in which service, whether or not recommended by Honda, might be done or of the possible hazardous consequences of each conceivable way, nor could Honda investigate all such ways. Anyone using service procedures or tools, whether or not recommended by Honda, must satisfy himself thoroughly that neither personal safety or vehicle safety will be jeopardized.

All information contained in this manual is based on the latest product information available at the time of printing. We reserve the right to make changes at any time without notice. No part of this publication may be reproduced, stored in a retrieval system, or transmitted, in any form, by any means, electronic, mechanical, photocopying, recording, or otherwise, without the prior written permission of the publisher. This includes text, images, and tables.

**Honda Motor Co., Ltd.  
Service Publication Office**

# Reference

## Symbols

### Replacement

The welding symbols in the removal/installation have these meanings.

×: 2-Plate spot welding

⊗: 3-Plate spot welding

⊠: 4-Plate spot welding

●: MAG plug welding

●: MAG welding (butt or fillet)

L=Welding length unit: mm (in)

( ) and ( )\*: The number of welds

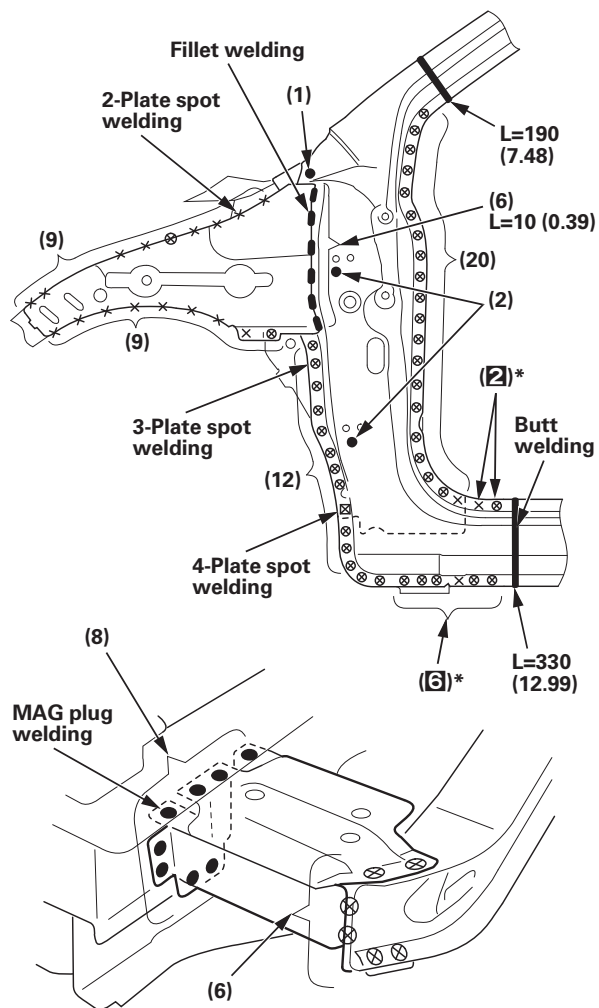

### Body Dimensional Drawings

Body measuring dimensions show the distance between the forward or upper edge of positioning bosses and/or holes shown in the detail illustration.

Black dots: Measuring point

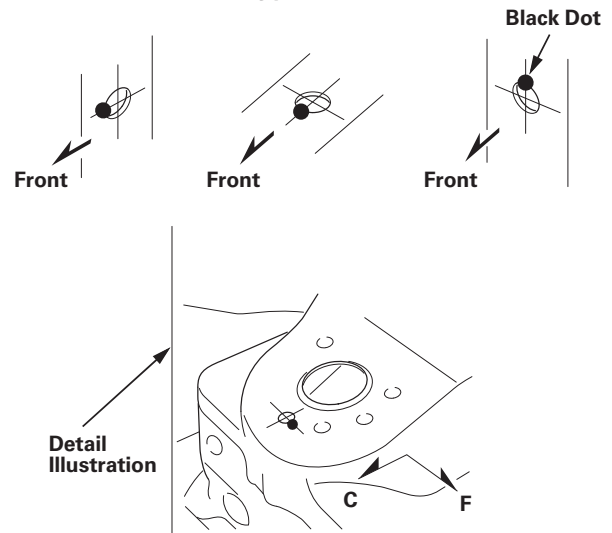

However, the measuring points in the frame repair chart are always the centers of the holes.

### Rust Prevention

The following type of illustration shows the areas where sealant is to be applied.

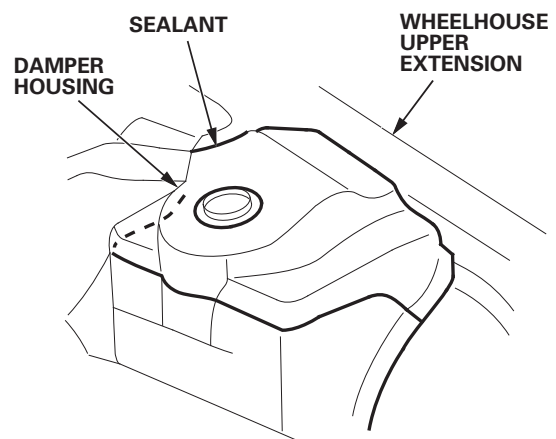

# General Information

## General Information

- Supplemental Restraint System (SRS) . . . . . 1-2
- SRS Component Replacement/Inspection After
  - Deployment . . . . . 1-4
- Battery Terminal Disconnection and Reconnection . . 1-5
- Identification Number Locations . . . . . 1-6
- Parts Marking . . . . . 1-7
- Lift and Support Points . . . . . 1-8
- Body Specifications/Wheel Alignment . . . . . 1-9
- Exterior Parts Removal/Installation . . . . . 1-10
- Front Body Construction . . . . . 1-12
- Roof and Side Panel Construction . . . . . 1-14
- Floor and Rear Body Construction . . . . . 1-16
- Door, Bumper Reinforcement Beams, and Boron
  - Steel (USIBOR 1500) Parts . . . . . 1-18
- Zinc-Plated Steel Plate Repair . . . . . 1-19
- High-Strength Steel Sheet Framed Areas . . . . . 1-20
- Precautions for High-Strength Steel Parts Area
  - Repair . . . . . 1-21
- Parts Replacement Description . . . . . 1-21
- Boron Steel (USIBOR 1500) Parts Welding
  - Conditions . . . . . 1-22

# General Information

## Supplemental Restraint System (SRS)

This model has an SRS which includes a driver's airbag in the steering wheel hub, a front passenger's airbag in the dashboard above the glove box, front seat belt tensioners in the front seat belt retractors, driver's seat belt outer lap tensioner in the front seat belt lower anchor, side airbags in the front seat-backs, and side curtain airbags in the sides of the roof. The SRS unit is separate from the airbag assembly and has built-in sensors. The following precautions should be observed when doing sheetmetal work, paint work, and repair work around the locations of the SRS components.

- The SRS unit (including the safing sensor and the impact sensor) is located under the dashboard and the side impact sensors are located in each side sill and rear wheel arch. The front impact sensors are located behind the right and left ends of the front bumper. Avoid any strong impact with a hammer or other tools when repairing the front side frame, the lower part of the dashboard, the side sill, and the rear wheel arch. Do not apply heat to these areas with a torch, etc.
- Take extra care when painting or doing body work in the area below the B-pillar. Do not expose the seat belt retractor and tensioner to heat guns, welding, or spraying equipment.
- SRS electrical connectors are identified by yellow color coding. Take care when repairing this area. Prevent damage to the harness.
- Do not apply heat of more than 212 °F (100 °C) when drying painted surfaces anywhere around the SRS components locations.
- If strong impact or high temperature need to be applied to the areas around the locations of SRS components, remove the components before doing the repair work.
- If any of the SRS-related components are damaged or deformed, be sure to replace them.

NOTE: For after-deployment procedures, and removal and replacement of SRS-related components, refer to the Odyssey Service Manual.

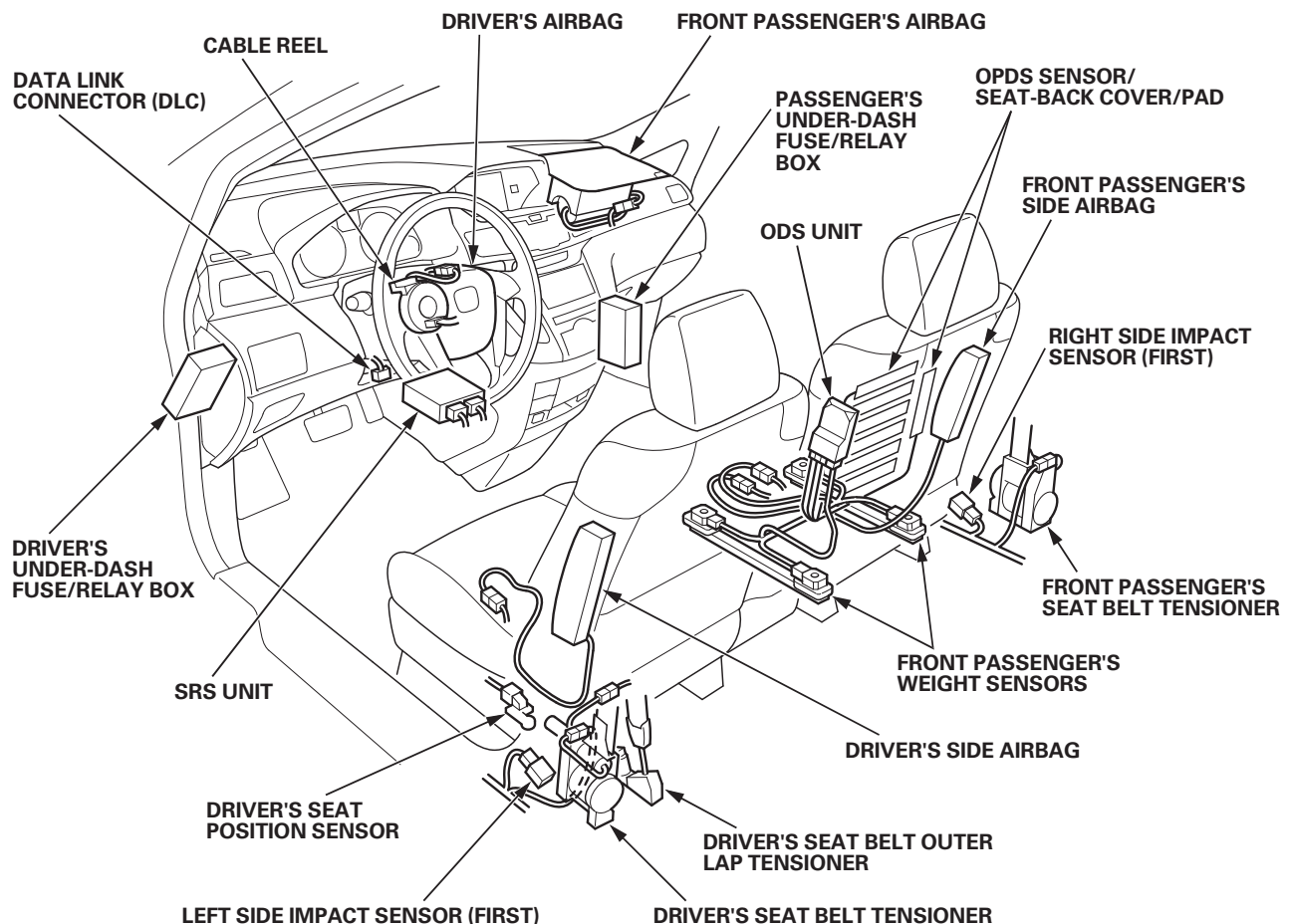

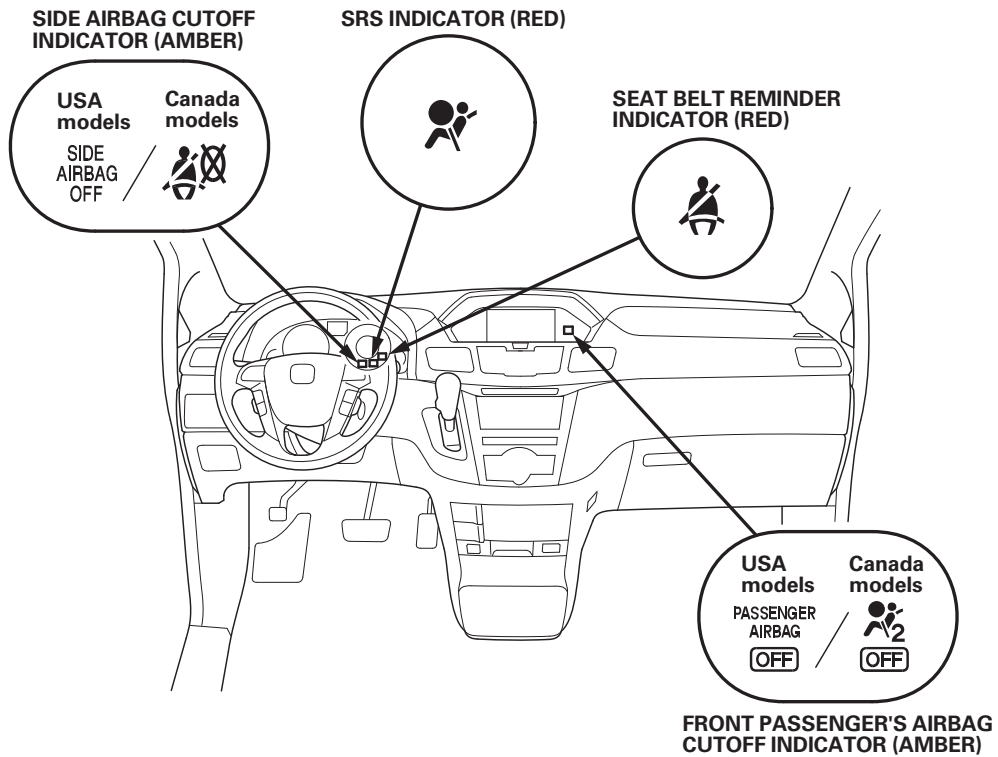
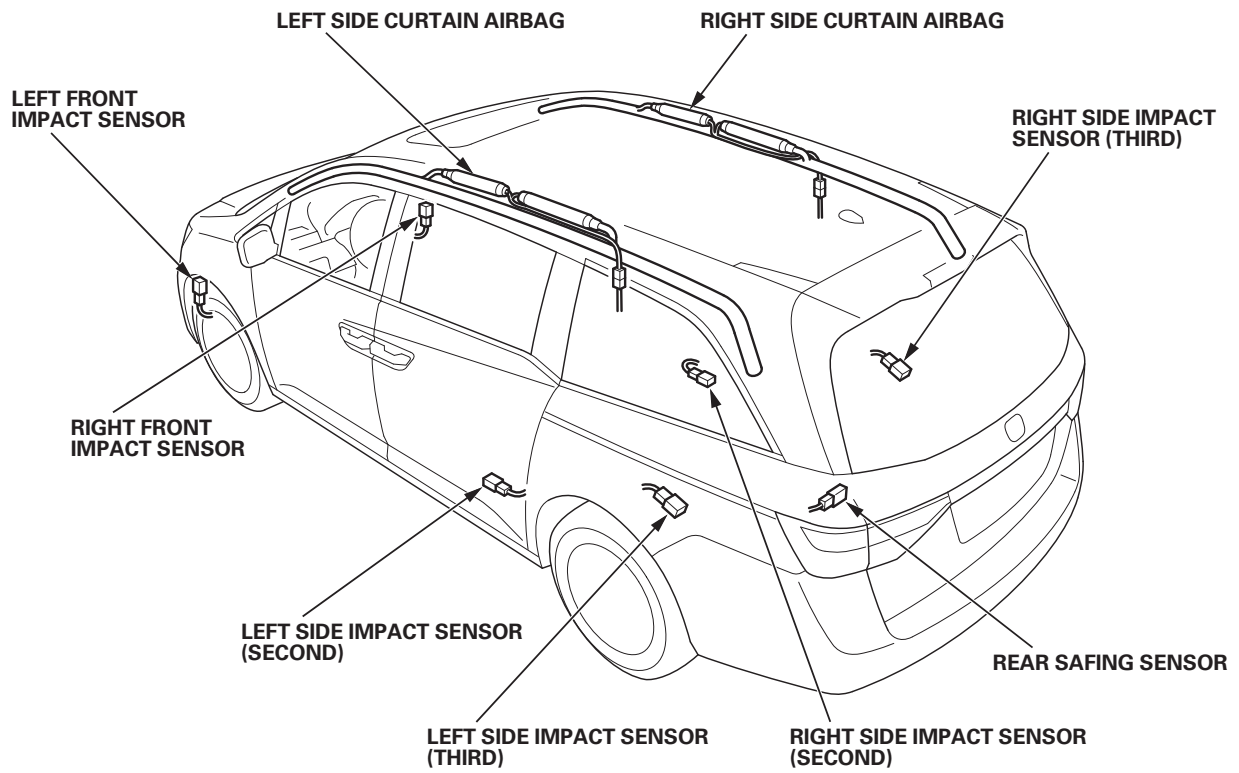

# General Information

## SRS Component Replacement/Inspection After Deployment

### NOTE:

- Before doing any SRS repairs, check for DTCs with the HDS; refer to the appropriate Odyssey Service Manual, for the less obvious deployed components (front seat belt tensioners, driver's seat belt outer lap tensioner, front impact sensors, side impact sensors, rear safing sensor, etc).
- If there is a breaking or damage found in harness relevant to the replacement parts shown below, replace it, do not repair.
- Do not replace the ODS unit unless it is physically damaged or a specific fault was found during DTC troubleshooting. Because it could complicate troubleshooting other DTCs.
- After a vehicle collision, do the ODS unit operation check; refer to the appropriate Odyssey Service Manual.
- After a vehicle collision, inspect the front seat active head restraints; refer to the appropriate Odyssey Service Manual.

After a collision where the front seat belt tensioners deployed, replace these items:

- SRS unit
- Front seat belt(s)
- Driver's seat belt outer lap tensioner
- Front impact sensor(s)

After a collision where the driver's seat belt outer lap tensioner deployed, replace these items:

- SRS unit
- Front seat belt(s)
- Driver's seat belt outer lap tensioner
- Front impact sensor(s)

After a collision where the front airbag(s) deployed, replace these items:

- SRS unit
- Deployed front airbag(s)
- Front seat belt(s)
- Driver's seat belt outer lap tensioner
- Front impact sensor(s)
- Dashboard

After a collision where the side airbag has deployed, replace the items for the side(s) that deployed:

- SRS unit
- Deployed side airbag(s)
- Side impact sensor(s) (first)
- Side impact sensor(s) (second)
- Side impact sensor(s) (third)
- Rear safing sensor
- B-pillar lower trim
- Seat frame and related parts
- Front seat belt(s)
- Driver's seat belt outer lap tensioner

After a collision where a side curtain airbag has deployed, replace the items for the side(s) that deployed:

- SRS unit
- Front seat belt(s)
- Driver's seat belt outer lap tensioner
- Deployed side curtain airbag(s)
- Side impact sensor(s) (first)
- Side impact sensor(s) (second)
- Side impact sensor(s) (third)
- Rear safing sensor
- A-pillar upper trim
- B-pillar upper trim
- C-pillar trim
- D-pillar trim
- Front grab handle
- Rear grab handle
- All related trim clips
- Sunvisor
- Headliner

After a moderate to severe side or rear collision, inspect for any damage on the side curtain airbag or other related components. Replace the components as needed.

During the repair process, inspect these areas:

- Inspect all the SRS wire harnesses. Replace, do not repair, any damaged harnesses.
- Inspect the cable reel for heat damage. If there is any damage, replace the cable reel; refer to the appropriate Odyssey Service Manual.

After the vehicle is completely repaired, turn the ignition switch to ON (II). If the SRS indicator comes on for about 6 seconds and then goes off, the SRS is OK. If the indicator does not function properly, use the HDS to check for the DTCs; refer to the appropriate Odyssey Service Manual. If you cannot retrieve a code, do the SRS Symptom Troubleshooting.



# Battery Terminal Disconnection and Reconnection

## Disconnection

NOTE: Some systems store data in memory (including seat position, mirror position, etc) that is lost when the battery is disconnected. Do the following procedures before disconnecting the battery.

1. Make sure you have the anti-theft code(s) for the audio system.
2. Make sure the ignition switch is in LOCK (0).
3. Disconnect and isolate the negative cable from the battery.

NOTE: Always disconnect the negative cable from the battery first.

4. Disconnect the positive cable from the battery.

## Reconnection

NOTE: Some systems store data in memory (including seat position, mirror position, etc) that is lost when the battery is disconnected. Do the following procedures to restore the systems back to normal operation.

1. Clean the battery terminals.
2. Test the battery; refer to the appropriate Odyssey Service Manual.
3. Reconnect the positive cable (A) to the battery (B) first, then reconnect the negative cable (C) to the battery.

NOTE: Always connect the positive cable to the battery first.

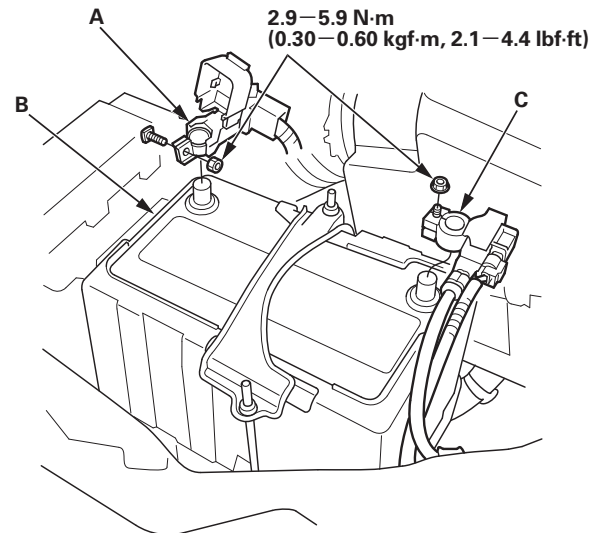

4. Apply multipurpose grease to the terminals to prevent corrosion.
5. Enter the anti-theft code(s) for the audio system.
6. Enter the audio presets.
7. Set the clock (for vehicles without navigation).

# General Information

## Identification Number Locations

Vehicle Identification Number (VIN)

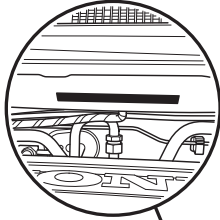

Vehicle Identification Number (VIN)

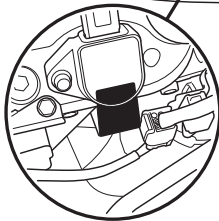
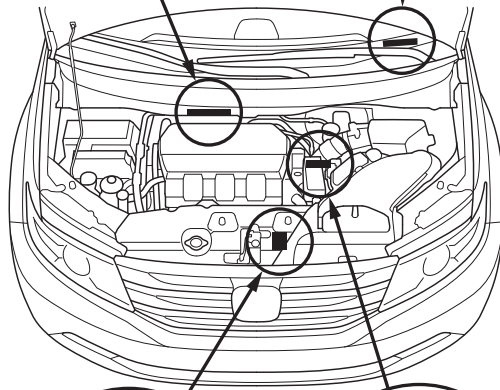
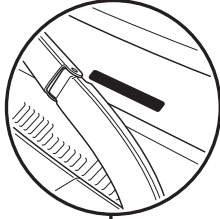

Engine Number

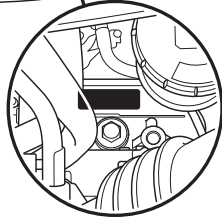

Transmission Number (5-speed A/T model)

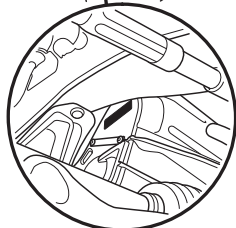
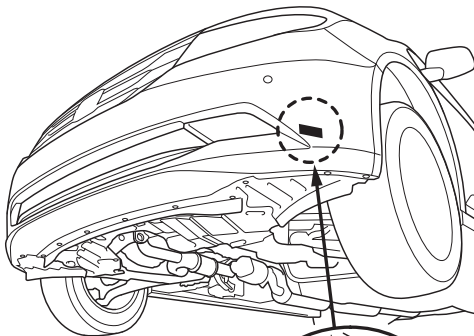

Transmission Number (6-speed A/T model)

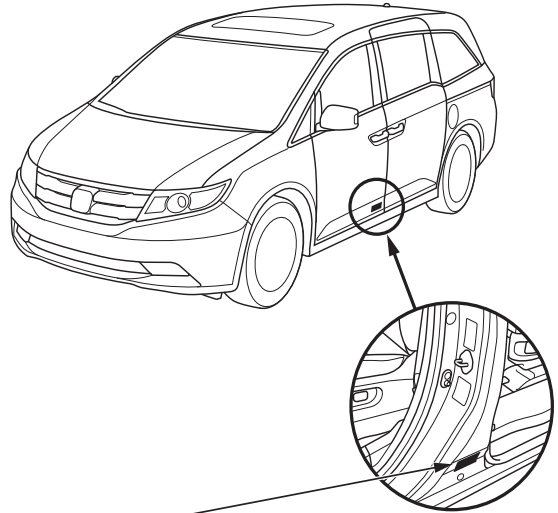

Vehicle Identification Number, Federal Motor Vehicle Safety Standard Certification, and Paint Code Label.

Vehicle Identification Number, Canadian Motor Vehicle Safety Standard Certification, and Paint Code Label.



PAINT CODE

INTERIOR COLOR CODE