



HONDA

HONDA



CB600FW

IMPORTANT SAFETY NOTICE

▲WARNING *Indicates a strong possibility of severe personal injury or death if instructions are not followed.*

CAUTION: *Indicates a possibility of equipment damage if instructions are not followed.*

NOTE: Gives helpful information.

Detailed descriptions of standard workshop procedures, safety principles and service operations are not included. It is important to note that this manual contains some warnings and cautions against some specific service methods which could cause **PERSONAL INJURY** to service personnel or could damage a vehicle or render it unsafe. Please understand that those warnings could not cover all conceivable ways in which service, whether or not recommended by Honda, might be done or of the possibly hazardous consequences of each conceivable way, nor could Honda investigate all such ways. Anyone using service procedures or tools, whether or not recommended by Honda, *must satisfy himself thoroughly* that neither personal safety nor vehicle safety will be jeopardized by the service methods or tools selected.

TYPE CODE

- Throughout this manual, the following abbreviations are used to identify individual model.

CODE	AREA TYPE	CODE	AREA TYPE
ED	EUROPEAN DIRECT SALES (Italy, Germany, Portugal, Norway, Finland, Denmark, Austria)	II H	NETHERLANDS TYPE II (Limited power/25 kw (34 PS); Spain)
II ED	EUROPEAN DIRECT SALES TYPE II (Limited power/37 kw (50 PS); Sweden, Germany)	E	U. K.
		F	FRANCE
III ED	EUROPEAN DIRECT SALES TYPE III (Limited power/25 kw (34 PS); Germany, Portugal)	G	GERMANY
		SW	SWITZERLAND
H	NETHERLANDS (Belgium, Spain)	U	AUSTRALIA

HOW TO USE THIS MANUAL

This service manual describes the service procedures for the CB600F.

Follow the Maintenance Schedule (Section 3) recommendations to ensure that the vehicle is in peak operating condition.

Performing the first scheduled maintenance is very important. It compensates for the initial wear that occurs during the break-in period.

Sections 1 and 3 apply to the whole motorcycle. Section 2 illustrates procedures for removal/installation of components that may be required to perform service described in the following sections. Sections 4 through 19 describe parts of the motorcycle, grouped according to location.

Find the section you want on this page, then turn to the table of contents on the first page of the section.

Most sections start with an assembly or system illustration, service information and troubleshooting for the section.

The subsequent pages give detailed procedure.

If you don't know the source of the trouble, go to section 21 Troubleshooting.

ALL INFORMATION, ILLUSTRATIONS, DIRECTIONS AND SPECIFICATIONS INCLUDED IN THIS PUBLICATION ARE BASED ON THE LATEST PRODUCT INFORMATION AVAILABLE AT THE TIME OF APPROVAL FOR PRINTING. HONDA MOTOR CO., LTD. RESERVES THE RIGHT TO MAKE CHANGES AT ANY TIME WITHOUT NOTICE AND WITHOUT INCURRING ANY OBLIGATION WHATEVER. NO PART OF THIS PUBLICATION MAY BE REPRODUCED WITHOUT WRITTEN PERMISSION. THIS MANUAL IS WRITTEN FOR PERSONS WHO HAVE ACQUIRED BASIC KNOWLEDGE OF MAINTENANCE ON HONDA MOTORCYCLES, MOTOR SCOOTERS OR ATVS.











HONDA MOTOR CO., LTD.
SERVICE PUBLICATION OFFICE

CONTENTS

	GENERAL INFORMATION	1
	FRAME/BODY PANELS/EXHAUST SYSTEM	2
	MAINTENANCE	3
ENGINE AND DRIVE TRAIN	LUBRICATION SYSTEM	4
	FUEL SYSTEM	5
	COOLING SYSTEM	6
	ENGINE REMOVAL/INSTALLATION	7
	CYLINDER HEAD/VALVES	8
	CLUTCH/GEARSHIFT LINKAGE	9
	ALTERNATOR/STARTER CLUTCH	10
	CRANKCASE/PISTON/CYLINDER	11
	CRANKSHAFT/TRANSMISSION	12
	CHASSIS	FRONT WHEEL/SUSPENSION/STEERING
REAR WHEEL/SUSPENSION		14
HYDRAULIC BRAKE		15
ELECTRICAL	BATTERY/CHARGING SYSTEM	16
	IGNITION SYSTEM	17
	ELECTRIC STARTER	18
	LIGHTS/METERS/SWITCHES	19
	WIRING DIAGRAMS	20
	TROUBLESHOOTING	21

SYMBOLS

The symbols used throughout this manual show specific service procedures. If supplementary information is required pertaining to these symbols, it would be explained specifically in the text without the use of the symbols.

	<p>Replace the part(s) with new one(s) before assembly.</p>
	<p>Use recommended engine oil, unless otherwise specified.</p>
	<p>Use molybdenum oil solution (mixture of the engine oil and molybdenum grease in a ratio of 1 : 1).</p>
	<p>Use multi-purpose grease (Lithium based multi-purpose grease NLGI # 2 or equivalent).</p>
	<p>Use molybdenum disulfide grease (containing more than 3 % molybdenum disulfide, NLGI # 2 or equivalent). Example: Molykote® BR-2 plus manufactured by Dow Corning, U. S. A. Multi-purpose M-2 manufactured by Mitsubishi Oil, Japan</p>
	<p>Use molybdenum disulfide paste (containing more than 40 % molybdenum disulfide, NLGI # 2 or equivalent). Example: Molykote® G-n paste, manufactured by Dow Corning, U. S. A. Honda Moly 60 (U. S. A. only) Rocol ASP manufactured by Rocol Limited, U. K. Rocol Paste manufactured by Sumico Lubricant, Japan</p>
	<p>Use silicone grease.</p>
	<p>Apply a locking agent. Use a middle strength locking agent unless otherwise specified.</p>
	<p>Apply sealant.</p>
	<p>Use DOT 4 brake fluid. Use the recommended brake fluid unless otherwise specified.</p>
	<p>Use Fork or Suspension Fluid.</p>

1. GENERAL INFORMATION

GENERAL SAFETY	1-1	TOOLS	1-17
SERVICE RULES	1-2	LUBRICATION & SEAL POINTS	1-19
MODEL IDENTIFICATION	1-3	CABLE & HARNESS ROUTING	1-22
SPECIFICATIONS	1-4	EMISSION CONTROL SYSTEMS	1-32
TORQUE VALUES	1-13		

GENERAL SAFETY

CARBON MONOXIDE

If the engine must be running to do some work, make sure the area is well ventilated. Never run the engine in an enclosed area.

▲WARNING

The exhaust contains poisonous carbon monoxide gas that can cause loss of consciousness and may lead to death.

Run the engine in an open area or with an exhaust evacuation system in an enclosed area.

GASOLINE

Work in a well ventilated area. Keep cigarettes, flames or sparks away from the work area or where gasoline is stored.

▲WARNING

Gasoline is extremely flammable and is explosive under certain conditions. KEEP OUT OF REACH OF CHILDREN.

HOT COMPONENTS

▲WARNING

Engine and exhaust system parts become very hot and remain hot for some time after the engine is run. Wear insulated gloves or wait until the engine and exhaust system have cooled before handling these parts.

USED ENGINE OIL

▲WARNING

Used engine oil may cause skin cancer if repeatedly left in contact with the skin for prolonged periods. Although this is unlikely unless you handle used oil on a daily basis, it is still advisable to thoroughly wash your hands with soap and water as soon as possible after handling used oil. KEEP OUT OF REACH OF CHILDREN.

BRAKE DUST

Never use an air hose or dry brush to clean the brake assemblies.

▲WARNING

Inhaled asbestos fibers have been found to cause respiratory disease and cancer.

BRAKE FLUID

CAUTION:

Spilling fluid on painted, plastic or rubber parts will damage them. Place a clean shop towel over these parts whenever the system is serviced. KEEP OUT OF REACH OF CHILDREN.

GENERAL INFORMATION

COOLANT

Under some condition, the ethylene glycol in engine coolant is combustible and its flame is not visible. If the ethylene glycol does ignite, you will not see any flame, but you can be burned.

▲WARNING

- *Avoid spilling engine coolant on the exhaust system or engine parts. They may be hot enough to cause the coolant to ignite and burn without a visible flame.*
- *Coolant (ethylene glycol) can cause some skin irritation and is poisonous if swallowed. KEEP OUT OF REACH OF CHILDREN.*
- *Do not remove the radiator cap when the engine is hot. The coolant is under pressure and could scald you.*
- *Keep hands and clothing away from the cooling fan, as it starts automatically.*

SERVICE RULES

1. Use genuine HONDA or HONDA-recommended parts and lubricants or their equivalents. Parts that don't meet HONDA's design specifications may cause damage to the motorcycle.
2. Use the special tools designed for this product to avoid damage and incorrect assembly.
3. Use only metric tools when servicing the motorcycle. Metric bolts, nuts and screws are not interchangeable with English fasteners.
4. Install new gaskets, O-rings, cotter pins, and lock plates when reassembling.
5. When tightening bolts or nuts, begin with the larger diameter or inner bolt first. Then tighten to the specified torque diagonally in incremental steps unless a particular sequence is specified.
6. Clean parts in cleaning solvent upon disassembly. Lubricate any sliding surfaces before reassembly.
7. After reassembly, check all parts for proper installation and operation.
8. Route all electrical wires as show on pages 1-22 through 1-31, Cable and Harness Routing.

BATTERY HYDROGEN GAS & ELECTROLYTE

▲WARNING

- *The battery gives off explosive gases; keep sparks, flames and cigarettes away. Provide adequate ventilation when charging.*
- *The battery contains sulfuric acid (electrolyte). Contact with skin or eyes may cause severe burns. Wear protective clothing and a face shield.*
 - *If electrolyte gets on your skin, flush with water.*
 - *If electrolyte gets in your eyes, flush with water for at least 15 minutes and call a physician immediately.*
- *Electrolyte is poisonous.*
 - *If swallowed, drink large quantities of water or milk and follow with milk of magnesia or vegetable oil and call a physician. KEEP OUT OF REACH OF CHILDREN.*

MODEL IDENTIFICATION

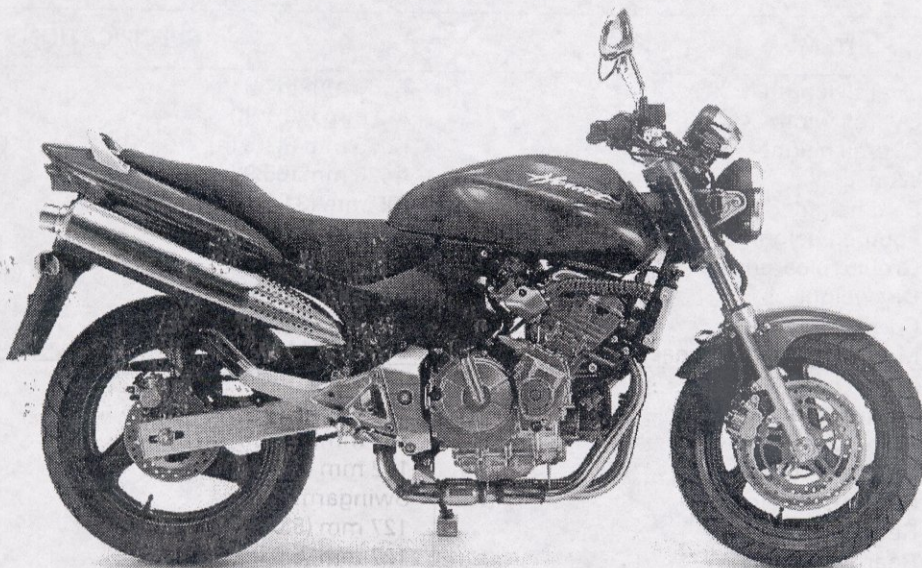

FRAME SERIAL NUMBER

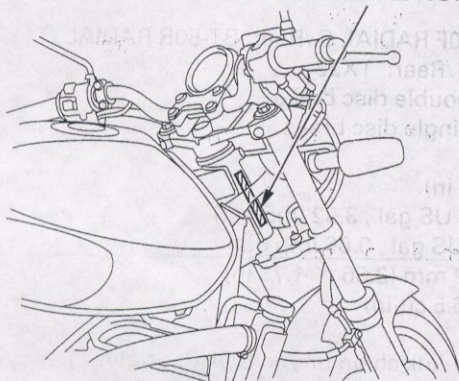

- (1) The frame serial number is stamped on the right side of the steering head.

ENGINE SERIAL NUMBER



- (2) The engine serial number is stamped on the lower right side of the crankcase.

CARBURETOR IDENTIFICATION NUMBER

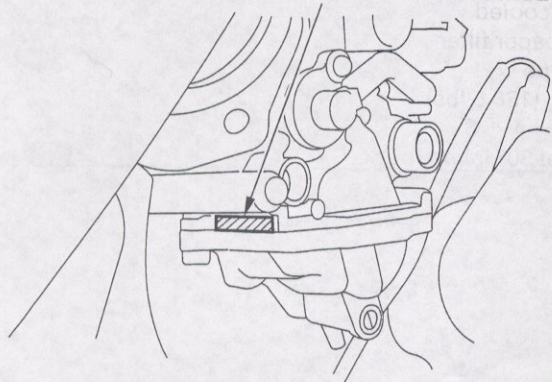

- (3) The carburetor identification number is stamped on the intake side of the carburetor body as shown.

COLOR LABEL

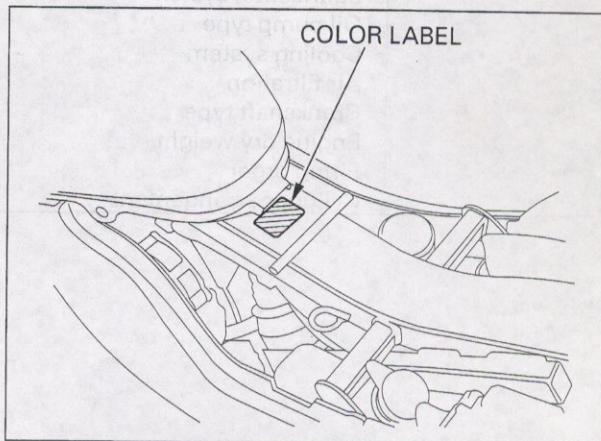

- (4) The color label is attached as shown. When ordering color-coded parts, always specify the designated color code.

SPECIFICATIONS

GENERAL		
	ITEM	SPECIFICATIONS
DIMENSIONS	Overall length	2,080 mm (81.9 in)
	Overall width	740 mm (29.1 in)
	Overall height	1,055 mm (41.5 in)
	Wheelbase	1,420 mm (55.9 in)
	Seat height	795 mm (31.3 in)
	Footpeg height	344 mm (13.5 in)
	Ground clearance	135 mm (5.3 in)
	Dry weight	176 kg (388 lbs)
	Curb weight	196 kg (432 lbs)
	Maximum weight capacity	188 kg (414 lbs)
FRAME	Frame type	Diamond
	Front suspension	Telescopic fork
	Front wheel travel	112 mm (4.4 in)
	Front axle travel	112 mm (4.4 in)
	Rear suspension	Swingarm
	Rear wheel travel	127 mm (5.0 in)
	Rear axle travel	127 mm (5.0 in)
	Rear damper	Nitrogen gas filled damper
	Front tire size	130/70ZR16 (61W) Radial
	Rear tire size	180/55ZR17 (73W) Radial
	Tire brand	
	Bridgestone	Front: BT-50F RADIAL G /Rear: BT-50R RADIAL G
	Michelin	Front: TX11/Rear: TX23
	Front brake	Hydraulic double disc brake
	Rear brake	Hydraulic single disc brake
	Caster angle	25°40'
	Trail length	98 mm (3.9 in)
Fuel tank capacity	16.0 ℓ (4.23 US gal , 3.52 Imp gal)	
Fuel reserve capacity	3.0 ℓ (0.79 US gal , 0.66 Imp gal)	
ENGINE	Bore and stroke	65.0 × 45.2 mm (2.56 × 1.78 in)
	Displacement	599 cm ³ (36.5 cu-in)
	Compression ratio	12.0 : 1
	Valve train	Silent multi-link chain driven DOHC, 4 valves per cylinder
	Intake valve	opens — at 1 mm
		closes — (0.04 in) lift
	Exhaust valve	opens — 15° BTDC
		closes — 35° ABDC
		38° BBDC
		7° ATDC
	Lubrication system	Forced pressure and wet sump
	Oil pump type	Trochoid
	Cooling system	Liquid cooled
	Air filtration	Oiled paper filter
Crankshaft type	Unit type	
Engine dry weight	61.9 kg (136.5 lbs)	
Firing order	1 - 2 - 4 - 3	
Cylinder arrangement	Vertical 30° inline four	

GENERAL (Cont'd)

ITEM		SPECIFICATIONS
CARBURETOR	Type Throttle bore	Constant velocity 34 mm (1.3 in)
DRIVE TRAIN	Clutch system Clutch operation system Transmission Primary reduction Final reduction Gear ratio 1st 2nd 3rd 4th 5th 6th Gearshift pattern	Multi-plate, wet Cable operated type Constant mesh, 6-speed 1.863 (82/44) 2.800 (42/15) 2.928 (41/14) 2.062 (33/16) 1.647 (28/17) 1.368 (26/19) 1.200 (24/20) 1.086 (25/23) Left foot operated return system, 1 - N - 2 - 3 - 4 - 5 - 6
ELECTRICAL	Ignition system Starting system Charging system Regulator/rectifier Lighting system	Full transistorized ignition Electric starter motor Triple phase output alternator SCR shorted/triple phase, full wave rectification Battery

GENERAL INFORMATION

Unit: mm (in)

LUBRICATION SYSTEM		STANDARD	SERVICE LIMIT
ITEM			
Engine oil capacity	At draining	3.5 l (3.7 US qt, 3.1 Imp qt)	_____
	At disassembly	4.2 l (4.4 US qt, 3.7 Imp qt)	_____
	At oil filter change	3.8 l (4.0 US qt, 3.3 Imp qt)	_____
Recommended engine oil		HONDA 4-stroke oil or equivalent motor oil API service classification SE, SF or SG Viscosity: SAE 10 W-40	_____
Oil pressure at oil pressure switch		490 kPa (5.0 kgf/cm ² , 71 psi) at 6,000 min ⁻¹ (rpm)/(80 °C/176 °F)	_____
Oil pump rotor	Tip clearance	0.15 (0.006) max.	0.20 (0.008)
	Body clearance	0.15 - 0.22 (0.006 - 0.009)	0.35 (0.014)
	Side clearance	0.02 - 0.07 (0.001 - 0.003)	0.10 (0.004)
Oil pump drive sprocket collar O. D.		34.050 - 34.075 (1.3405 - 1.3415)	34.03 (1.340)
Oil pump drive sprocket I. D.		35.025 - 35.075 (1.3789 - 1.3809)	35.10 (1.382)

FUEL SYSTEM		SPECIFICATIONS
ITEM		
Carburetor identification number	Except SW type	VP49A
	SW type	VP49B
Main jet		No.1/4; # 100, No.2/3; # 102
Slow jet		# 40
Jet needle		J7SL
Pilot screw initial opening	Except SW type	1 3/4 turns out
	SW type	2 1/8 turns out
Float level		13.7 mm (0.54 in)
Idle speed		1,300 ± 100 min ⁻¹ (rpm)
Carburetor vacuum difference		Within 30 mm-Hg (1.2 in Hg)
Base carburetor for synchronization		No.3 carburetor

COOLING SYSTEM

ITEM		SPECIFICATIONS
Coolant capacity	Radiator and engine	2.0 ℓ (2.1 US qt, 1.8 Imp qt)
	Reserve tank	0.20 ℓ (0.21 US qt, 0.18 Imp qt)
Radiator cap relief pressure		108 – 137 kPa (1.1 – 1.4 kgf/cm ² , 16 – 20 psi)
Thermostat	Begin to open	80 – 84 °C (176 – 183 °F)
	Fully open	95 °C (203 °F)
	Valve lift	8 mm (0.3 in) minimum

CYLINDER HEAD/VALVES

Unit: mm (in)

ITEM			STANDARD	SERVICE LIMIT
Cylinder compression			1,275 – 1,314 kPa (13.0 – 13.4 kgf/cm ² , 185 – 191 psi) at 300 min ⁻¹ (rpm)	————
Cylinder head warpage			————	0.10 (0.004)
Valve, valve guide	Valve clearance	IN	0.16 ± 0.03 (0.006 ± 0.001)	————
		EX	0.22 ± 0.03 (0.009 ± 0.001)	————
	Valve stem O. D.	IN	3.975 – 3.990 (0.1565 – 0.1571)	3.965 (0.1561)
		EX	3.965 – 3.980 (0.1561 – 0.1567)	3.955 (0.1557)
	Valve guide I. D.	IN	4.000 – 4.012 (0.1575 – 0.1580)	4.04 (0.159)
		EX	4.000 – 4.012 (0.1575 – 0.1580)	4.04 (0.159)
	Stem-to-guide clearance	IN	0.010 – 0.037 (0.0004 – 0.0015)	0.075 (0.0030)
		EX	0.020 – 0.047 (0.0008 – 0.0019)	0.085 (0.0033)
	Valve guide projection above cylinder head	IN	13.10 – 13.30 (0.516 – 0.524)	————
		EX	11.30 – 11.50 (0.445 – 0.453)	————
Valve seat width		IN/EX	0.90 – 1.10 (0.035 – 0.043)	1.5 (0.06)
Valve spring free length		IN/EX	35.36 (1.392)	33.86 (1.333)
Valve lifter	Valve lifter O. D.	IN/EX	25.978 – 25.993 (1.0228 – 1.0233)	25.97 (1.022)
	Valve lifter bore I. D.	IN/EX	26.010 – 26.026 (1.0240 – 1.0246)	26.04 (1.025)
Camshaft	Cam lobe height	IN	36.140 – 36.380 (1.4228 – 1.4323)	36.11 (1.422)
		EX	35.300 – 35.540 (1.3898 – 1.3992)	35.27 (1.389)
	Journal O. D.		23.959 – 23.980 (0.9433 – 0.9441)	24.955 (0.9825)
	Runout		————	0.05 (0.002)
	Oil clearance		0.020 – 0.062 (0.0008 – 0.0024)	0.10 (0.004)

GENERAL INFORMATION

CLUTCH/GEARSHIFT LINKAGE		Unit: mm (in)	
ITEM		STANDARD	SERVICE LIMIT
Clutch lever free play		10–20 (3/8–13/16)	—
Clutch spring free length		49.7 (1.96)	48.3 (1.90)
Clutch disc thickness		2.92–3.08 (0.115–0.121)	2.60 (0.102)
Clutch plate warp		—	0.30 (0.012)
Clutch outer guide	I. D.	21.994–22.007 (0.8659–0.8664)	22.017 (0.8668)
	O. D.	34.975–34.991 (1.3770–1.3776)	34.965 (1.3766)
Mainshaft O. D. at clutch outer guide		21.980–21.993 (0.8654–0.8659)	21.95 (0.864)

ALTERNATOR/STARTER CLUTCH		Unit: mm (in)	
ITEM		STANDARD	SERVICE LIMIT
Starter driven gear O. D.		51.699–51.718 (2.0354–2.0361)	51.684 (2.0348)

CRANKCASE/PISTON/CYLINDER		Unit: mm (in)		
ITEM		STANDARD	SERVICE LIMIT	
Cylinder	I. D.	65.000–65.015 (2.5591–2.5596)	65.10 (2.563)	
	Out of round	—	0.10 (0.004)	
	Taper	—	0.10 (0.004)	
	Warp	—	0.10 (0.004)	
Piston, piston rings	Piston mark direction		"IN" mark facing toward the intake side	
	Piston O. D.		64.970–64.990 (2.5579–2.5587)	
	Piston O. D. measurement point		11 mm (0.4 in) from bottom of skirt	
	Piston pin bore I. D.		17.002–17.008 (0.6694–0.6696)	
	Piston pin O. D.		16.994–17.000 (0.6691–0.6693)	
	Piston-to-piston pin clearance		0.002–0.014 (0.0001–0.0006)	
	Piston ring-to-ring groove clearance	Top	0.025–0.060 (0.0010–0.0024)	0.08 (0.003)
		Second	0.015–0.050 (0.0006–0.0020)	0.08 (0.003)
	Piston ring end gap	Top	0.20–0.35 (0.008–0.014)	0.5 (0.02)
		Second	0.35–0.50 (0.014–0.020)	0.7 (0.03)
Oil (side rail)		0.20–0.70 (0.008–0.028)	1.0 (0.04)	
Cylinder-to-piston clearance		0.010–0.045 (0.0004–0.0018)	0.10 (0.004)	
Connecting rod small end I. D.		17.016–17.034 (0.6699–0.6706)	17.04 (0.671)	
Connecting rod-to-piston pin clearance		0.016–0.040 (0.0006–0.0016)	—	
Crank pin oil clearance		0.028–0.052 (0.0011–0.0020)	0.06 (0.002)	

Unit: mm (in)

CRANKSHAFT/TRANSMISSION

ITEM		STANDARD	SERVICE LIMIT	
Crankshaft	Side clearance	0.10—0.25 (0.004—0.010)	0.30 (0.012)	
	Runout	—————	0.05 (0.002)	
	Main journal oil clearance	0.020—0.045 (0.0008—0.0018)	0.05 (0.002)	
Transmission	Gear I. D.	M5, M6	28.000—28.021 (1.1024—1.1032)	28.04 (1.104)
		C2, C3, C4	31.000—31.025 (1.2205—1.2215)	31.04 (1.222)
	Bushing O. D.	M5, M6	27.959—27.980 (1.1007—1.1016)	27.94 (1.100)
		C2	30.959—30.980 (1.2189—1.2197)	30.94 (1.218)
		C3, C4	30.950—30.975 (1.2185—1.2195)	30.93 (1.218)
	Bushing I. D.	M5	24.985—25.006 (0.9837—0.9845)	25.016 (0.9849)
		C2	27.985—28.006 (1.1018—1.1026)	28.021 (1.1032)
	Gear-to-bushing clearance	M5, M6	0.020—0.062 (0.0008—0.0024)	—————
		C2, C3, C4	0.020—0.070 (0.0008—0.0028)	—————
	Mainshaft O. D.	M5	24.967—24.980 (0.9830—0.9835)	24.960 (0.9827)
		Clutch outer guide	21.980—21.993 (0.8654—0.8659)	21.95 (0.864)
	Countershaft O. D.	C2	27.967—27.980 (1.1011—1.1016)	27.96 (1.101)
	Bushing-to-shaft clearance	M5	0.005—0.039 (0.0002—0.0015)	—————
C2		0.005—0.039 (0.0002—0.0015)	—————	
Shift fork, fork shaft	Shift fork	Fork I. D.	12.000—12.021 (0.4724—0.4733)	12.030 (0.4736)
		Claw thickness	5.93—6.00 (0.233—0.236)	5.90 (0.232)
	Fork shaft O. D.		11.957—11.968 (0.4707—0.4712)	11.95 (0.470)

GENERAL INFORMATION

FRONT WHEEL/SUSPENSION/STEERING		Unit: mm (in)	
ITEM		STANDARD	SERVICE LIMIT
Minimum tire tread depth		_____	1.5 (0.06)
Cold tire pressure	Driver only	250 kPa (2.50 kgf/cm ² , 36 psi)	_____
	Driver and passenger	250 kPa (2.50 kgf/cm ² , 36 psi)	_____
Axle runout		_____	0.20 (0.008)
Wheel rim runout	Radial	_____	2.0 (0.08)
	Axial	_____	2.0 (0.08)
Fork	Spring free length	309.2 (12.17)	303.0 (11.93)
	Spring direction	With the tapered end facing down	_____
	Tube runout	_____	0.20 (0.008)
	Recommended fork fluid	Fork fluid	_____
	Fluid level	102 (4.0)	_____
Fluid capacity		486 ± 2.5 cm ³ (16.4 ± 0.08 US oz, 17.1 ± 0.09 Imp oz)	_____
Steering head bearing pre-load		0.98 – 1.47 N (0.10 – 0.15 kgf, 0.22 – 0.33 lbf)	_____

REAR WHEEL/SUSPENSION			Unit: mm (in)	
ITEM			STANDARD	SERVICE LIMIT
Minimum tire tread depth			_____	2.0 (0.08)
Cold tire pressure	Driver only		290 kPa (2.90 kgf/cm ² , 42 psi)	_____
	Driver and passenger		290 kPa (2.90 kgf/cm ² , 42 psi)	_____
Axle runout			_____	0.20 (0.008)
Wheel rim runout	Radial		_____	2.0 (0.08)
	Axial		_____	2.0 (0.08)
Drive chain	Size/link	DID	525VM2 – 110LE	_____
		RK	525RO – 110LE	_____
	Slack		30 – 40 (1.2 – 1.6)	50 (2.0)
Shock absorber pre-load adjuster standard position			2nd groove	_____

Unit: mm (in)

HYDRAULIC BRAKE			
ITEM		STANDARD	SERVICE LIMIT
Front	Specified brake fluid	DOT 4	—
	Brake disc thickness	4.5 (0.18)	3.5 (0.14)
	Brake disc runout	—	0.30 (0.012)
	Master cylinder I. D.	14.000 – 14.043 (0.5512 – 0.5529)	14.055 (0.5533)
	Master piston O. D.	13.957 – 13.984 (0.5495 – 0.5506)	13.945 (0.5490)
	Caliper cylinder I. D.	27.000 – 27.050 (1.0630 – 1.0650)	27.060 (1.0654)
	Caliper piston O. D.	26.935 – 26.968 (1.0604 – 1.0617)	26.910 (1.0594)
Rear	Specified brake fluid	DOT 4	—
	Brake pedal height	67.5 (2.66)	—
	Brake disc thickness	5.0 (0.20)	4.0 (0.16)
	Brake disc runout	—	0.30 (0.012)
	Master cylinder I. D.	14.000 – 14.043 (0.5512 – 0.5529)	14.055 (0.5533)
	Master piston O. D.	13.957 – 13.984 (0.5495 – 0.5506)	13.945 (0.5490)
	Caliper cylinder I. D.	38.18 – 38.23 (1.503 – 1.505)	38.24 (1.506)
	Caliper piston O. D.	38.098 – 38.148 (1.4999 – 1.5019)	38.09 (1.500)

BATTERY/CHARGING SYSTEM				
ITEM		SPECIFICATIONS		
Battery	Capacity	12V – 6Ah		
	Current leakage	1.2 mA max.		
	Voltage (20°C/68°F)	Fully charged	13.0 – 13.2V	
		Needs charging	Below 12.3V	
	Charging current	Normal	0.9 A/5 – 10 h	
Quick		4.0 A/1.0 h		
Alternator	Capacity	0.34 kW/5,000 min ⁻¹ (rpm)		
	Charging coil resistance (20°C/68°F)	0.1 – 1.0 Ω		
Regulator/rectifier regulated voltage		13.0 – 15.5 V/5,000 min ⁻¹ (rpm)		

IGNITION SYSTEM		
ITEM		SPECIFICATIONS
Spark plug		CR9EH – 9 (NGK)
		U27FER9 (DENSO)
Spark plug gap		0.8 – 0.9 mm (0.03 – 0.04 in)
Ignition coil peak voltage		100 V minimum
Ignition pulse generator peak voltage		0.7 V minimum
Ignition timing ("F" mark)		7° BTDC at idle

Unit: mm (in)

ELECTRIC STARTER			
ITEM		STANDARD	SERVICE LIMIT
Starter motor brush length		12.0 – 13.0 (0.47 – 0.51)	4.5 (0.18)

GENERAL INFORMATION

LIGHTS/METERS/SWITCHES

ITEM		SPECIFICATIONS
Bulbs	Headlight (Hi/Lo)	12V – 60/55W
	Position light (Except U type)	12V – 4W
	Brake/taillight	12V – 21/5W × 2
	Turn signal light	12V – 21W × 4
	Instrument light	12V – 1.7W × 3
	Turn signal indicator	12V – 1.7W × 2
	High beam indicator	12V – 1.7W
	Neutral indicator	12V – 1.7W
	Oil pressure indicator	12V – 1.7W
Fuse	Main fuse	30 A
	Sub fuse	10 A × 4
Fan motor switch	Start to close (ON)	98 – 102 °C (208 – 216 °F)
	Stop to open	93 – 97 °C (199 – 207 °F)
Coolant temperature sensor resistance	at 80°C/176°F	45 – 60 Ω
	at 120°C/248°F	10 – 20 Ω

TORQUE VALUES

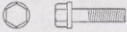
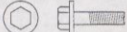
FASTENER TYPE	TORQUE N·m (kgf·m, lbf·ft)	FASTENER TYPE	TORQUE N·m (kgf·m, lbf·ft)
5 mm hex bolt and nut	5 (0.5 , 3.6)	5 mm screw	4 (0.4 , 2.9)
6 mm hex bolt and nut	10 (1.0 , 7)	6 mm screw	9 (0.9 , 6.5)
8 mm hex bolt and nut	22 (2.2 , 16)	6 mm flange bolt (8 mm head: small flange)	10 (1.0 , 7)
10 mm hex bolt and nut	34 (3.5 , 25)		
12 mm hex bolt and nut	54 (5.5 , 40)	6 mm flange bolt (10 mm head: large flange) and nut	12 (1.2 , 9)
			
		8 mm flange bolt and nut	26 (2.7 , 20)
		10 mm flange bolt and nut	39 (4.0 , 29)

- Torque specifications listed below are for important fasteners.
- Others should be tightened to standard torque values listed above.

- NOTES:
1. Apply sealant to the threads.
 2. Apply a locking agent to the threads.
 3. Apply grease to the threads.
 4. Stake.
 5. Apply oil to the threads and flange surface.
 6. Apply clean engine oil to the O-ring.
 7. U-nut
 8. ALOC bolt: replace with a new one.
 9. CT bolt

ENGINE

ITEM	Q'TY	THREAD DIA. (mm)	TORQUE N·m (kgf·m, lbf·ft)	REMARKS
MAINTENANCE:				
Spark plug	4	10	12 (1.2 , 9)	
Timing hole cap	1	45	18 (1.8 , 13)	NOTE 3
Oil drain bolt	1	12	29 (3.0 , 22)	
Oil filter cartridge	1	20	10 (1.0 , 7)	NOTE 6
LUBRICATION SYSTEM:				
Oil filter boss	1	20	18 (1.8 , 13)	NOTE 2
Oil pump driven sprocket bolt	1	6	15 (1.5 , 11)	NOTE 2
Oil pump assembly bolt	1	6	8 (0.8 , 5.8)	NOTE 9
Oil cooler sealing bolt	1	18	49 (5.0 , 36)	NOTE 2
FUEL SYSTEM:				
Carburetor assembly bolt/nut, 5 mm	1	5	5 (0.5 , 3.6)	
6 mm	1	6	10 (1.0 , 7)	
Boost joint for synchronization	3	5	2 (0.25 , 1.8)	
Insulator band screw	8	5		See page 1-14
COOLING SYSTEM:				
Water pump cover bolt	2	6	13 (1.3 , 9)	NOTE 9
Coolant temperature sensor unit	1	PT 1/8	10 (1.0 , 7)	NOTE 1
Water hose joint	1	12	29 (3.0 , 22)	
Sealing special bolt	1	10	12 (1.2 , 9)	

GENERAL INFORMATION

ENGINE (Cont'd)

ITEM	Q'TY	THREAD DIA. (mm)	TORQUE N-m (kgf-m, lbf-ft)	REMARKS
CYLINDER HEAD/VALVES:				
Cylinder head sealing bolt	1	18	32 (3.3 , 24)	NOTE 2
Cylinder head socket bolt	10	9	47 (4.8 , 35)	NOTE 5
No.1 intake vacuum port plug	1	5	3 (0.3 , 2.2)	
Cylinder head cover bolt	6	6	10 (1.0 , 7)	
Camshaft holder flange bolt	20	6	12 (1.2 , 9)	NOTE 5
Breather plate flange bolt	2	6	12 (1.2 , 9)	NOTE 2
Cam sprocket bolt	4	7	20 (2.0 , 14)	NOTE 2
Cylinder head stud bolt	8	8	—	See below
Cam chain tensioner cap nut	1	6	12 (1.2 , 9)	
Cam chain lifter sealing bolt	1	6	10 (1.0 , 7)	
CLUTCH/GEARSHIFT LINKAGE:				
Clutch center lock nut	1	20	108 (11.0 , 80)	NOTE 4, 5
Clutch spring bolt	4	6	12 (1.2 , 9)	
Shift drum center socket bolt	1	8	23 (2.3 , 17)	NOTE 2
Shift drum stopper pivot bolt	1	6	12 (1.2 , 9)	
Gearshift return spring pin	1	8	23 (2.3 , 17)	
ENGINE REMOVAL/INSTALLATION:				
Drive sprocket special bolt	1	10	54 (5.5 , 40)	
CRANKCASE/PISTON/CYLINDER:				
Main journal bolt	10	8	25 (2.6 , 19)	NOTE 5
Crankcase bolt, 10 mm	1	10	39 (4.0 , 29)	
8 mm	1	8	24 (2.4 , 17)	
Lower crankcase sealing bolt, 20 mm	1	20	29 (3.0 , 22)	NOTE 2
Lower crankcase sealing bolt, 14 mm	1	14	25 (2.5 , 18)	NOTE 2
Connecting rod nut	8	7	25 (2.6 , 19)	NOTE 5
ALTERNATOR:				
Flywheel flange bolt	1	10	103 (10.5 , 76)	NOTE 5
Stator mounting socket bolt	4	6	12 (1.2 , 9)	
Alternator wire clamp socket bolt	1	6	10 (1.0 , 7)	
Starter clutch outer socket bolt	6	6	16 (1.6 , 12)	NOTE 2
IGNITION SYSTEM:				
Ignition pulse generator rotor special bolt	1	10	59 (6.0 , 43)	
ELECTRIC STARTER/STARTER CLUTCH:				
Starter motor terminal nut	1	6	10 (1.0 , 7)	
LIGHTS/METERS/SWITCHES:				
Oil pressure switch	1	PT 1/8	12 (1.2 , 9)	NOTE 1
Oil pressure switch terminal screw	1	4	2 (0.2 , 1.4)	
Neutral switch	1	10	12 (1.2 , 9)	

Cylinder head stud bolt:

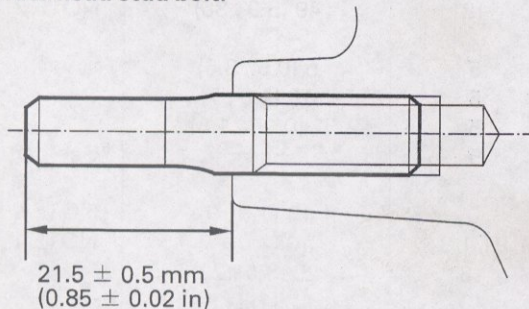

Connecting tube clamp:

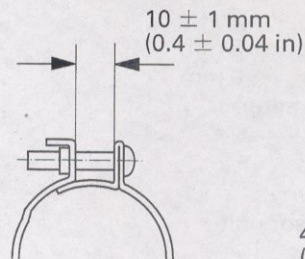

Insulator clamp:

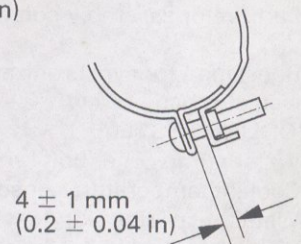

FRAME

ITEM	Q'TY	THREAD DIA. (mm)	TORQUE N·m (kgf·m, lbf·ft)	REMARKS
FRAME BODY PANELS/EXHAUST SYSTEM:				
Side stand pivot bolt	1	10	15 (1.5 , 11)	
Side stand pivot lock nut	1	10	39 (4.0 , 29)	
Footpeg holder bolt	4	8	26 (2.7 , 20)	
Exhaust pipe joint nut	6	7	20 (2.0 , 14)	See page 1-16
Muffler/exhaust pipe stay bolt	2	8	22 (2.2 , 16)	
Muffler protector bolt	1	6	12 (1.2 , 9)	
Muffler band bolt	2	8	22 (2.2 , 16)	
Grab rail mounting bolt	4	8	26 (2.7 , 20)	
Front fender mounting bolt	2	6	12 (1.2 , 9)	
Rearview mirror mounting nut	2	10	34 (3.5 , 25)	
Rear reflector mounting nut	1	5	5 (0.5 , 3.6)	
Side cover upper mounting bolt	2	5	1 (0.15 , 1.1)	
Side cover lower mounting bolt	2	5	4 (0.4 , 2.9)	
Rear turn signal unit mounting nut	2	10	5 (0.5 , 3.6)	
Taillight mounting nut	2	6	7 (0.7 , 5.1)	
Fuel valve nut	1	22	34 (3.5 , 25)	
Fuel tank stay bolt	2	6	12 (1.2 , 9)	
COOLING SYSTEM:				
Coolant temperature sensor	1	PT 1/8	9 (0.9 , 6.5)	
Fan motor switch	1	16	18 (1.8 , 13)	NOTE 1
Fan motor mounting nut	3	6	5 (0.5 , 3.6)	
Cooling fan motor nut	1	6	3 (0.28 , 2.0)	NOTE 2
ENGINE MOUNTING:				
Front engine hanger nut	2	10	54 (5.5 , 40)	
Engine hanger bracket bolt	2	8	22 (2.2 , 16)	
Rear engine hanger nut (upper)	1	10	54 (5.5 , 40)	
Rear engine hanger nut (lower)	1	10	54 (5.5 , 40)	
GEARSHIFT LINKAGE:				
Gearshift pedal link bolt (gearshift pedal side)	1	8	26 (2.7 , 20)	
Gearshift pedal link bolt (gearshift spindle side)	1	6	20 (2.0 , 14)	
FRONT WHEEL/SUSPENSION/STEERING:				
Handlebar holder bolt	4	8	26 (2.7 , 20)	
Steering stem nut	1	24	103 (10.5 , 76)	See page 13-30
Top thread A	1	26	—	
Top thread B	1	26	—	
Fork top bridge pinch bolt	2	8	23 (2.3 , 17)	
Fork bottom bridge pinch bolt	2	10	39 (4.0 , 29)	
Front axle bolt	1	14	59 (6.0 , 43)	
Front axle holder bolt	2	8	22 (2.2 , 16)	
Front brake disc mounting bolt	12	6	20 (2.0 , 14)	NOTE 8
Fork cap	2	37	23 (2.3 , 17)	
Fork socket bolt	2	8	20 (2.0 , 14)	NOTE 2
REAR WHEEL/SUSPENSION:				
Rear axle nut	1	16	88 (9.0 , 65)	NOTE 7
Rear brake disc mounting nut	4	8	42 (4.3 , 31)	NOTE 8
Final driven sprocket nut	5	12	108 (11.0 , 80)	NOTE 7
Swingarm pivot nut	1	14	88 (9.0 , 65)	NOTE 7
Drive chain case bolt	2	6	12 (1.2 , 9)	
Drive chain slider bolt	2	6	9 (0.9 , 6.5)	
Drive chain adjuster lock nut	2	8	21 (2.1 , 15)	
Rear shock absorber upper mounting nut	1	10	37 (3.8 , 27)	NOTE 7
Rear shock absorber lower mounting nut	1	10	37 (3.8 , 27)	NOTE 7

FRAME (Cont'd)

ITEM	Q'TY	THREAD DIA. (mm)	TORQUE N·m (kgf·m, lbf·ft)	REMARKS
HYDRAULIC BRAKE:				
Front brake master cylinder holder bolt	2	6	12 (1.2, 9)	
Front brake master cylinder cap screw	2	4	1 (0.15, 1.1)	
Brake lever pivot bolt	1	6	1 (0.1, 0.7)	
Brake lever pivot nut	1	6	6 (0.6, 4.3)	
Front brake switch screw	1	4	1 (0.12, 0.9)	
Front brake caliper mounting bolt	4	8	30 (3.1, 22)	NOTE 8
Front brake caliper slide pin (main)	2	12	23 (2.3, 17)	NOTE 2
Front brake caliper slide pin (sub)	2	8	13 (1.3, 9)	NOTE 2
Pad pin	3	10	18 (1.8, 13)	
Pad pin plug	3	10	2 (0.25, 1.8)	
Front brake hose clamp bolt	2	6	12 (1.2, 9)	NOTE 8
Brake caliper bleeder	3	8	6 (0.6, 4.3)	
Rear master cylinder mounting bolt	2	6	12 (1.2, 9)	
Rear master cylinder hose joint screw	1	4	1 (0.15, 1.1)	NOTE 2
Rear master cylinder push rod nut	1	8	18 (1.8, 13)	
Rear brake caliper slide pin (main)	2	12	27 (2.8, 20)	NOTE 2
Rear brake caliper slide pin (sub)	1	8	23 (2.3, 17)	NOTE 8
Rear brake hose clamp bolt	1	6	9 (0.9, 6.5)	NOTE 8
Brake hose oil bolt	5	10	34 (3.5, 25)	
LIGHTS/METERS/SWITCHES:				
Ignition switch mounting bolt	2	8	25 (2.5, 18)	NOTE 2

Exhaust pipe joint nut tightening sequence:

