

2012 CBR1000RR PARTS LIST

CONTENTS

INSTRUCTIONS FOR USE OF PARTS LIST.....	3- 2
---	------

ENGINE GROUP

E- 1	ENGINE POWER UP KIT.....	3- 3
E- 2	OIL COOLER	3- 4
E- 3	OIL PAN SET	3- 5
E- 4	THERMOSTAT / OIL FILLER CAP	3- 6
E- 5	CLUTCH	3- 7
E- 6	A.C. GENERATOR SET	3- 8
E- 7	TRANSMISSION SET	3- 9
E- 7-1	TRANSMISSION (OPTIONAL PARTS)	3-10
E- 8	AIR FUNNEL SET	3-12
E- 9	THROTTLE BODY	3-13

FRAME GROUP

F- 1	THROTTLE / CLUTCH CABLE	3-14
F- 2	UPPER COWL STAY	3-15
F- 3	FRONT FORK	3-16
F- 4	STEERING DAMPER	3-18
F- 5	FRONT BRAKE	3-19
F- 6	REAR BRAKE	3-20
F- 7	FRONT WHEEL / AXLE SET	3-22
F- 8	REAR WHEEL	3-24
F- 9	FUEL TANK SET	3-25
F-10	BREATHER CASE SET	3-26
F-11	AIR INJECTION PLUG SET	3-27
F-12	EXHAUST SET	3-28
F-13	SWINGARM	3-30
F-14	REAR CUSHION	3-33
F-15	HARNESS SET	3-35
F-15-1	HARNESS SET	3-37
F-16	DATALOGGER / SHIFT FORCE SENSOR	3-38
F-17	ENGINE HUNGER BOLT	3-39
F-18	SEAT RAIL SET	3-40
F-19	RADIATOR	3-41

INDEX	3-42
-------------	------

Block No.

E-1
ENGINE POWER UP KIT

2012 CBR1000RR

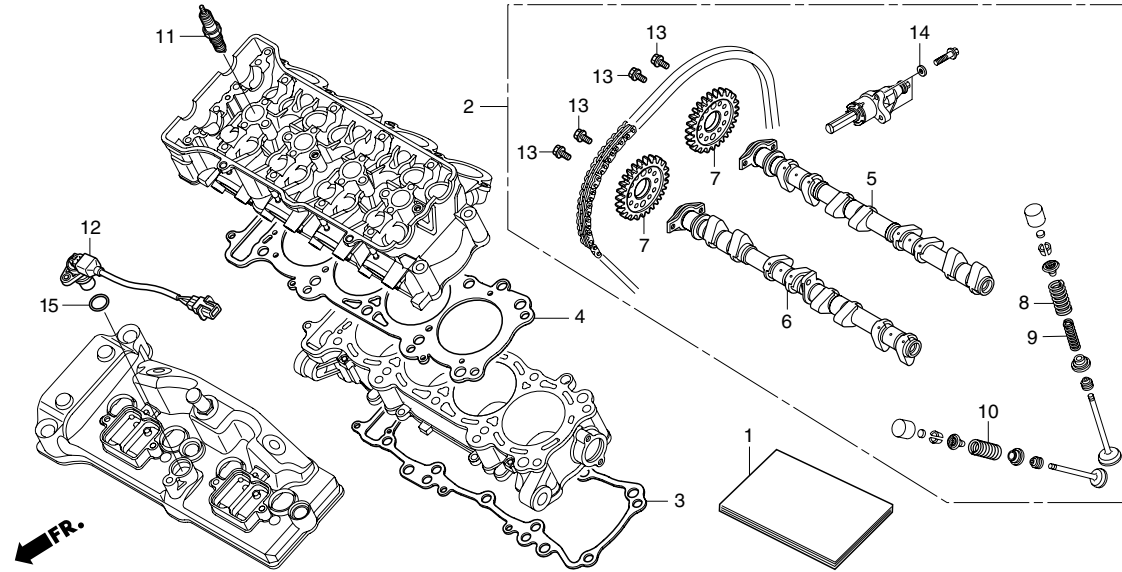

Note

The parts which have no "Ref No" in the illustration are Honda products.

Ref. No.	Part No.	Description	Reqd. No.	Remarks
• 1	00X32-NLR-D30	SET UP MANUAL PARTS LIST	1	
• 2	06110-NLR-A30	ENGINE POWER UP KIT(1) JSB.....	1	
• 3	12191-NLR-A31	GASKET, CYLINDER 0.20	1	20
•	12192-NLR-A31	GASKET, CYLINDER 0.30	1	30
•	12193-NLR-A31	GASKET, CYLINDER 0.15	1	15
• 4	12251-NLR-A31	GASKET, CYLINDER HEAD 0.55	1	Blue paint
•	12252-NLR-A31	GASKET, CYLINDER HEAD 0.65	1	Orange paint
•	12253-NLR-A31	GASKET, CYLINDER HEAD 0.70	1	Green paint
•	12254-NLR-A31	GASKET, CYLINDER HEAD 0.75	1	Yellow paint
• 5	14110-MFL-R10	CAM SHAFT COMP, IN.....	1	
• 6	14210-MFL-R10	CAM SHAFT COMP, EXH.....	1	
• 7	14321-NLR-A30	SPROCKET, CAM	2	
• 8	14751-MFL-R10	SPG, IN VALVE OUTER	8	Brown paint
• 9	14752-MFL-R10	SPG, IN VALVE INNER	8	Brown paint
• 10	14761-MFL-R10	SPG, EX VALVE.....	8	Sky blue paint
• 11	31910-NLR-A31	SPARK PLUG (R0459A-10)	4	
• 12	36140-NLR-B00	PULSER ASSY., CAM	1	
• 13	90082-NL9-710	BOLT, FLANGE KNOCK, 7 x 10.5.....	4	
14	90488-425-000	WASHER, SEALING 6 mm.....	2	
15	91303-KF0-003	O-RING, 14.8 x 2.4 (ARAI)	1	

Block No.

E-2
OIL COOLER

2012 CBR1000RR

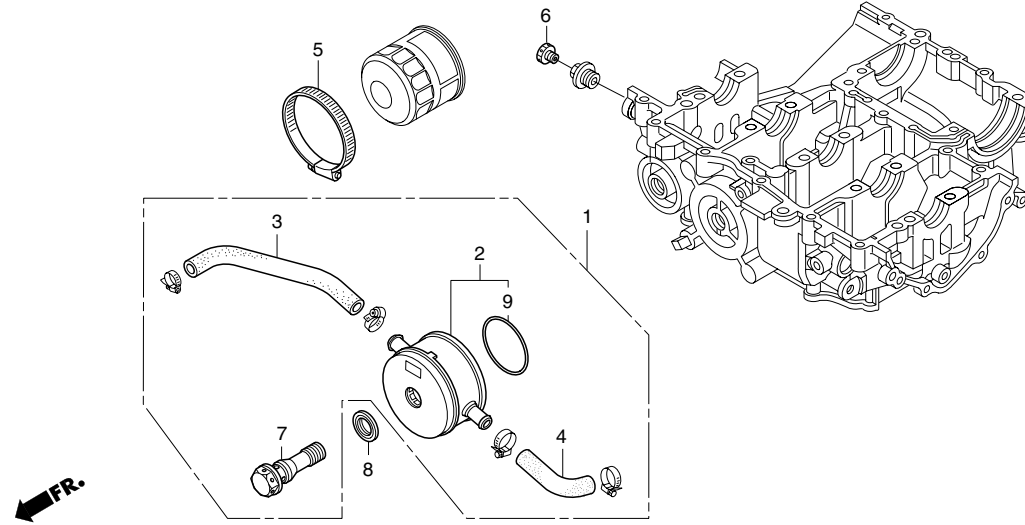

Ref. No.	Part No.	Description	Reqd. No.	Remarks
• 1	06180-NLR-A30	OIL COOLER SET	1	2010 MODEL YEAR
• 2	15700-MFL-R11	COOLER COMP., OIL	1	2010 MODEL YEAR
•	15700-MGP-R10	COOLER COMP., OIL	1	2012 MODEL YEAR
• 3	19526-MFL-R10	HOSE A, OIL/C.....	1	
• 4	19529-MFL-R10	HOSE C, OIL/C.....	1	
5	50252-GC4-830	BAND, SUB TANK.....	1	
• 6	90003-NL5-000	PLUG, TAPER	1	hole for wire lock
• 7	90019-N1A -D00	BOLT, OIL COOLER.....	1	hole for wire lock
8	90402-MFJ-D01	WASHER, SEALING, 34.5 mm.....	1	STD.
9	91354-MCT-003	O-RING, OIL COOLER.....	1	STD.