

INTRODUCTION

TO THE READER

- This manual is written for an experienced technician to provide technical information needed to maintain and repair this machine.
- Be sure to thoroughly read this manual for correct product information and service procedures.
- If you have any questions or comments, at if you found any errors regarding the contents of this manual, please contact using "Service Manual Revision Request Form. at the end of this manual.
(Note: Do not tear off the form. Copy it for usage.):
Publications Marketing & Product Support
Hitachi Construction Machinery Co. Ltd.
TEL: 81-298-32-7173
FAX: 81-298-31-1162

ADDITIONAL REFERENCES

- Please refer to the materials listed below in addition to this manual.
 - The Operator's Manual
 - The Parts Catalog
- Operation Manual of the Engine
- Parts Catalog of the Engine
- Hitachi Training Material

MANUAL COMPOSITION

- This manual consists of three portions: the Technical Manual (Operational Principle), the Technical Manual (Troubleshooting) and the Workshop Manual.
- Information included in the Technical Manual (Operational Principle):
technical information needed for redeliver and delivery, operation and activation of all devices and systems.
- Information included in the Technical Manual (Troubleshooting):
technical information needed for operational performance tests, and troubleshooting procedures.
- Information included in the Workshop Manual:
technical information needed for maintenance and repair of the machine, tools and devices needed for maintenance and repair, maintenance standards, and removal/installation and assemble/disassemble procedures.

PAGE NUMBER

- Each page has a number, located on the center lower part of the page, and each number contains the following information:

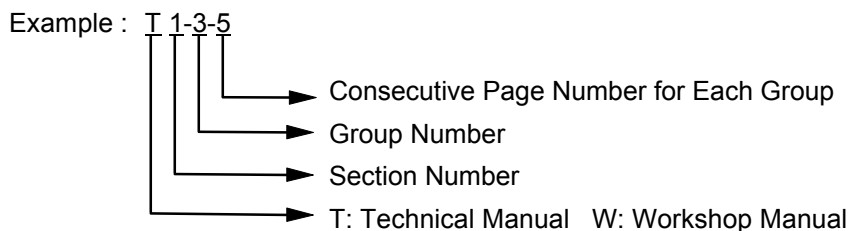



INTRODUCTION

SAFETY ALERT SYMBOL AND HEADLINE NOTATIONS

In this manual, the following safety alert symbol and signal words are used to alert the reader to the potential for personal injury or machine damage.

 This is the safety alert symbol. When you see this symbol, be alert to the potential for personal injury. Never fail to follow the safety instructions prescribed along with the safety alert symbol. The safety alert symbol is also used to draw attention to component/part weights. To avoid injury and damage, be sure to use appropriate lifting techniques and equipment when lifting heavy parts.

-  **CAUTION:**
Indicated potentially hazardous situation which could, if not avoided, result in personal injury or death.
- **IMPORTANT:**
Indicates a situation which, if not conformed to the instructions, could result in damage to the machine.
-  **NOTE:**
Indicates supplementary technical information or know-how.

UNITS USED

- SI Units (International System of Units) are used in this manual. MKS system units and English units are also indicated in parentheses just behind SI units.

Example : 24.5 MPa (250 kgf/cm², 3560 psi)

A table for conversion from SI units to other system units is shown below for reference purposes.

Quantity	To Convert From	Into	Multiply By	Quantity	To Convert From	Into	Multiply By
Length	mm	in	0.03937	Pressure	MPa	kgf/cm ²	10.197
	mm	ft	0.003281		MPa	psi	145.0
Volume	L	US gal	0.2642	Power	kW	PS	1.360
	L	US qt	1.057		kW	HP	1.341
	m ³	yd ³	1.308	Temperature	°C	°F	°C×1.8+32
Weight	kg	lb	2.205	Velocity	km/h	mph	0.6214
Force	N	kgf	0.10197		min ⁻¹	rpm	1.0
	N	lbf	0.2248	Flow rate	L/min	US gpm	0.2642
Torque	N·m	kgf·m	1.0197		mL/rev	cc/rev	1.0
	N·m	lbf·ft	0.7375				

SECTION AND GROUP CONTENTS

TECHNICAL MANUAL (Operational Principle)

SECTION 1 GENERAL

Group 1 Specification
Group 2 Component Layout
Group 3 Component Specifications

SECTION 2 SYSTEM

Group 1 Control System
Group 2 Front Control System
Group 3 Hydraulic System
Group 4 Electrical System

SECTION 3 COMPONENT OPERATION

Group 1 Pump Device
Group 2 Swing Device
Group 3 Control Valve
Group 4 Pilot Valve
Group 5 Travel Device
Group 6 Others (Upperstructure)
Group 7 Others (Undercarriage)

TECHNICAL MANUAL (Troubleshooting)

SECTION 4 OPERATIONAL PERFORMANCE TEST

Group 1 Introduction
Group 2 Standard
Group 3 Engine Test
Group 4 Excavator Test
Group 5 Component Test
Group 6 Adjustment

SECTION 5 TROUBLESHOOTING

Group 1 General
Group 2 Component Layout
Group 3 Troubleshooting A
Group 4 Troubleshooting B
Group 5 Troubleshooting C
Group 6 Troubleshooting D
Group 7 Electrical System Inspection
Group 8 ICX

All information, illustrations and specifications in this manual are based on the latest product information available at the time of publication.

The right is reserved to make changes at any time without notice.

WORKSHOP MANUAL

SECTION 1 GENERAL

Group 1 Precautions for Disassembling and Assembling
Group 2 Tightening Torque
Group 3 Painting
Group 4 Bleed Air from Hydraulic Oil Tank

SECTION 2 UPPERSTRUCTURE

Group 1 Cab
Group 2 Counterweight
Group 3 Main Frame
Group 4 Pump Device
Group 5 Control Valve
Group 6 Swing Device
Group 7 Pilot Valve
Group 8 Pilot Shut-Off Valve
Group 9 Shockless Valve
Group 10 Solenoid Valve

SECTION 3 UNDERCARRIAGE

Group 1 Swing Bearing
Group 2 Travel Device
Group 3 Center Joint
Group 4 Track Adjuster
Group 5 Front Idler
Group 6 Upper and Lower Roller
Group 7 Track

SECTION 4 FRONT ATTACHMENT

Group 1 Front Attachment
Group 2 Cylinder
Group 3 Holding Valve

SECTION 5 ENGINE

COPYRIGHT(C)2002

Hitachi Construction Machinery Co., Ltd.

Tokyo, Japan

All rights reserved

SECTION 1 GENERAL

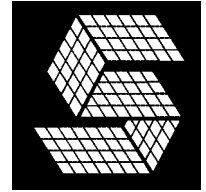

CONTENTS

Group 1 Specification

Specifications	T1-1-1
Working Ranges and Machine	
Transportation Dimensions	T1-1-3

Group 2 Component Layout

Main Components.....	T1-2-1
Electrical System (Overall System)	T1-2-2
Electrical System (Front Attachment)	T1-2-4
Electrical System	
(Monitor and Switches)	T1-2-5
Electrical System (Battery).....	T1-2-9
Electrical System (Pressure Sensor).....	T1-2-9
Solenoid Valve	T1-2-10
Control Valve	T1-2-11
Pump Device	T1-2-12
Swing Device	T1-2-12
Travel Device.....	T1-2-12

Group 3 Component Specifications

Engine	T1-3-1
Engine Accessories	T1-3-4
Hydraulic Component	T1-3-5
Filter	T1-3-7
Electrical Component.....	T1-3-7

(Blank)

GENERAL / Specifications

SPECIFICATIONS

ZAXIS75US-A

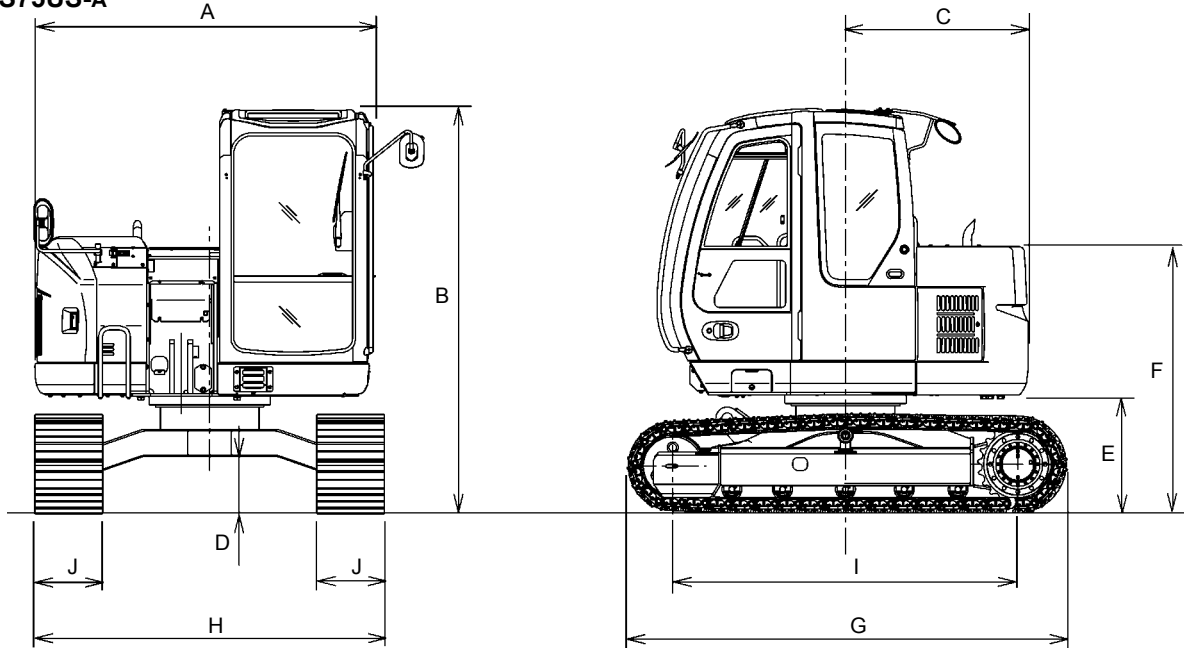

T1CG-01-01-009

Model		ZAXIS75US-A
Front-End Attachment Type	–	1.62 m Arm
Bucket Capacity (Heaped)	–	PCSA: 0.28 m ³ (0.37 yd ³), CECE: 0.24 m ³
Operating Weight	kg (lb)	7100 (15700)
Basic Machine Weight	kg (lb)	5890 (13000)
Engine	–	ISUZU CC-4JG1 40.5 kW / 2100 min ⁻¹ (55 PS / 2100 rpm)
A: Overall Width	mm (ft in)	2320 (7 ft 7 in)
B: Cab Height	mm (ft in)	2690 (8 ft 10 in)
C: Rear End Swing Radius	mm (ft in)	1210 (4 ft 0 in)
D: Minimum Ground Clearance	mm (ft in)	360 * (1 ft 2 in)
E: Counterweight Clearance	mm (ft in)	760 * (2 ft 6 in)
F: Engine Cover Height	mm (ft in)	1740 * (5 ft 9 in)
G: Undercarriage Length	mm (ft in)	2920 (9 ft 7 in)
H: Undercarriage Width	mm (ft in)	2320 (7 ft 7 in)
I: Sprocket Center to Idler Center	mm (ft in)	2290 (7 ft 6 in)
J: Track Shoe Width	mm (ft in)	450 (1' 6") (Grouser Shoe)
Ground Pressure	kPa (kgf/cm ² , psi)	30 (0.31 ft, 4.4 in)
Swing Speed	min ⁻¹ (rpm)	11
Travel Speed (Fast/Slow)	km/h (mph)	5.0/3.3 (8.1/5.3)
Gradeability	Degree (%)	35 (70)

NOTE: Dimensions marked * don't include the shoe lug height.

GENERAL / Specifications

ZAXIS75UR

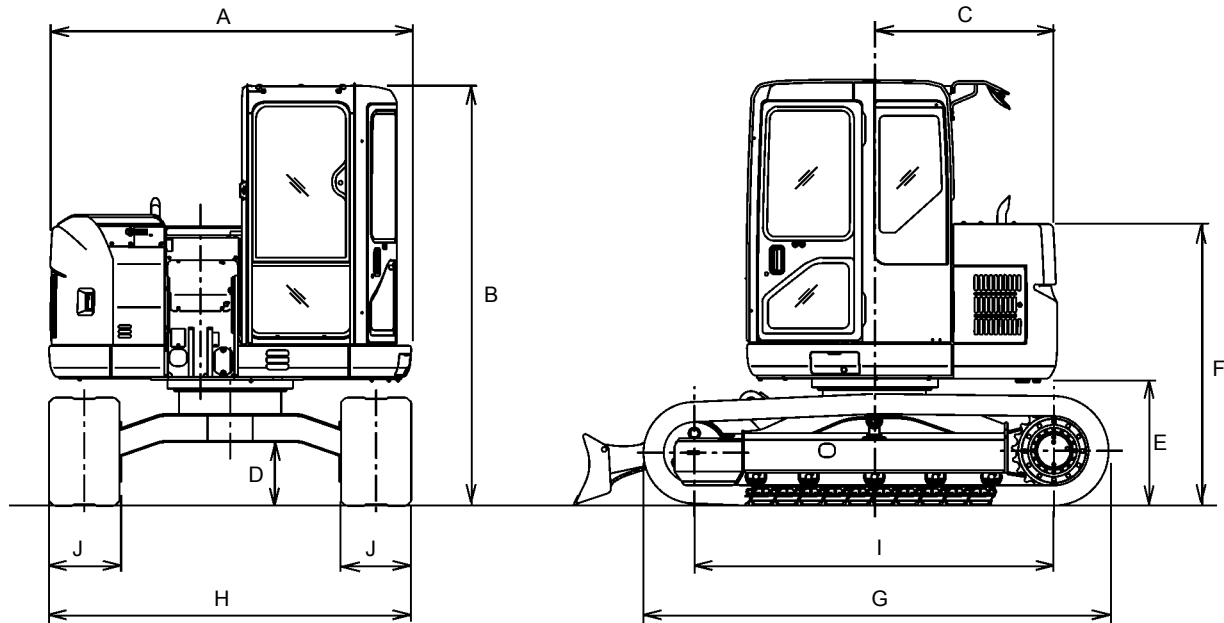

T1CF-01-01-021

Model	ZAXIS75UR	
Front-End Attachment Type	-	Offset
Bucket Capacity (Heaped)	-	PCSA: 0.28 m ³ (0.37 yd ³), CECE: 0.24 m ³
Operating Weight	kg (lb)	8200 (18100)
Basic Machine Weight	kg (lb)	6300 (13900)
Engine	-	ISUZU CC-4JG1 40.5 kW / 2100 min ⁻¹ (55 PS / 2100 rpm)
A: Overall Width	mm (ft in)	2320 (7ft 7in)
B: Cab Height	mm (ft in)	2720 (8 ft 11 in)
C: Rear End Swing Radius	mm (ft in)	1160 (3 ft 10 in)
D: Minimum Ground Clearance	mm (ft in)	410 (1 ft 10 in)
E: Counterweight Clearance	mm (ft in)	810 (2 ft 8 in)
F: Engine Cover Height	mm (ft in)	1790 (5 ft 11 in)
G: Undercarriage Length	mm (ft in)	2960 (9 ft 9 in)
H: Undercarriage Width	mm (ft in)	2320 (7 ft 7 in)
I: Sprocket Center to Idler Center	mm (ft in)	2290 (7 ft 6 in)
J: Track Shoe Width	mm (ft in)	450 (1' 6") (Pat Crawler)
Ground Pressure	kPa (kgf/cm ² , psi)	35 (0.36 ft, 5.1 in)
Swing Speed	min ⁻¹ (rpm)	11
Travel Speed (Fast/Slow)	km/h (mph)	5.0/3.3 (8.1/5.3)
Gradeability	Degree (%)	35 (70)

GENERAL / Specifications

WORKING RANGES AND MACHINE TRANSPORTATION DIMENSIONS

ZAXIS75US-A

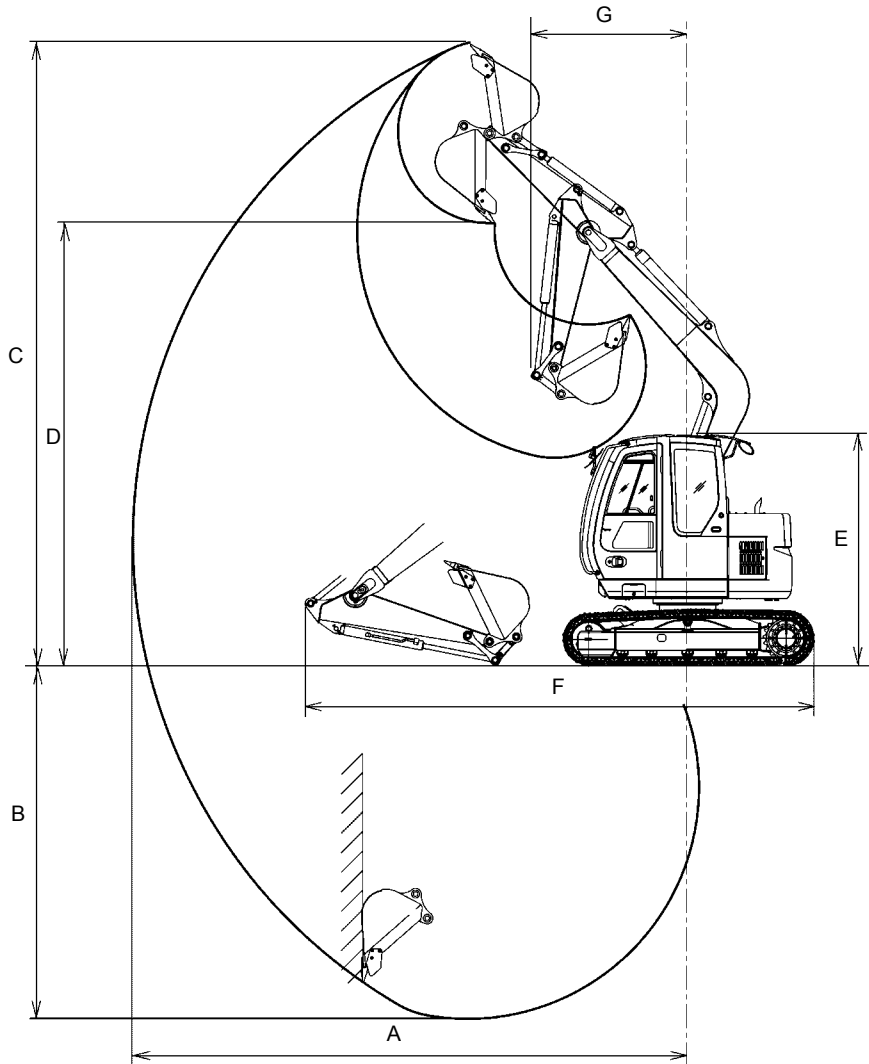

T1CG-01-01-010

Item	Category	1.62 m (5 ft 4 in) Arm
A: Maximum Digging Reach		6430 (21 ft 1 in)
B: Maximum Digging Depth		4110 (13 ft 6 in)
C: Maximum Cutting Height		7210 (23 ft 8 in)
D: Maximum Dumping Height		5210 (17 ft 1 in)
E: Transport Height		2690 (8 ft 10 in)
F: Overall Transport Length		5870 (19 ft 3 in)
G: Minimum Swing Radius		1810 (5 ft 11 in)

 **NOTE:** Dimensions marked * includes the shoe lug height.

GENERAL / Specifications

ZAXIS75UR

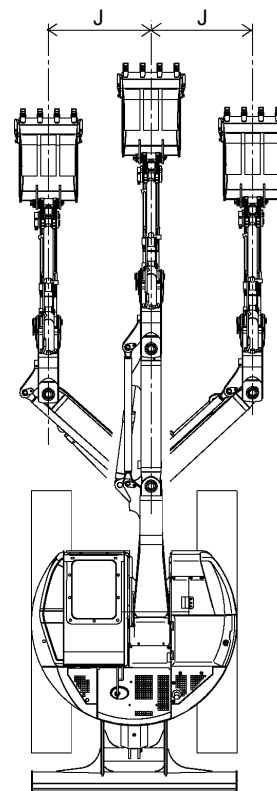
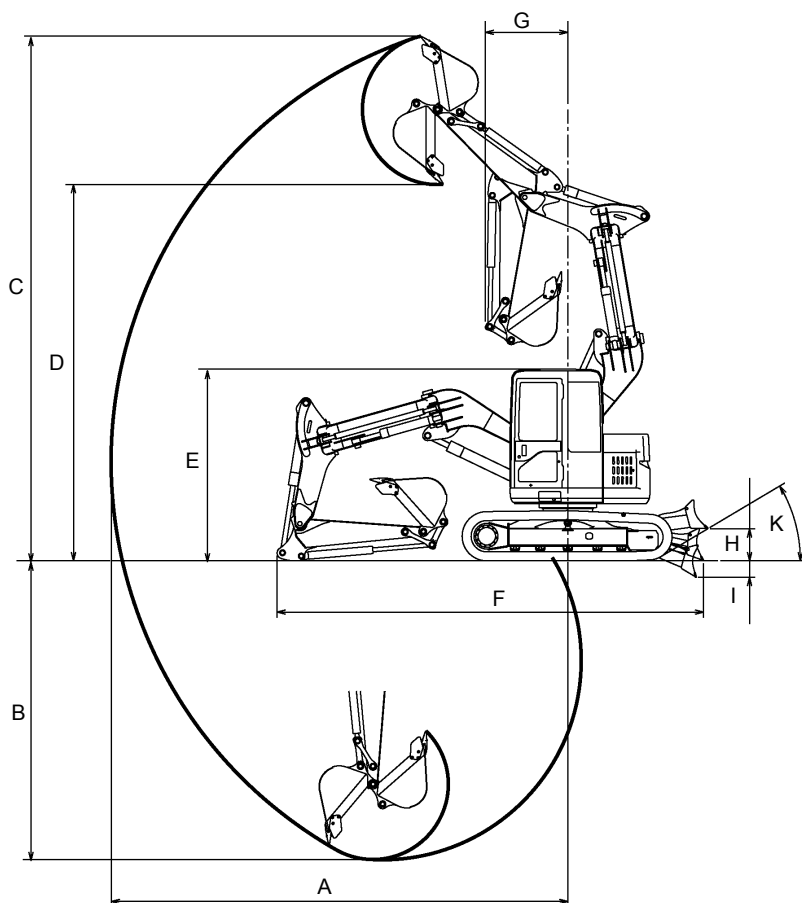

T1CF-01-01-023

T1CF-01-01-022

Item	Category	1.73 m Offset Front Attachment		
		Left Offset	Not Operating Offset	Right Offset
A: Maximum Digging Reach	(mm)	5930 (19 ft 6 in)	6440 (21 ft 2 in)	5940 (19 ft 6 in)
B: Maximum Digging Depth	(mm)	3820 (12 ft 6 in)	4220 (13 ft 10 in)	3830 (12 ft 7 in)
C: Maximum Cutting Height	(mm)	6890 (22 ft 7 in)	7400 (24 ft 3 in)	6900 (22 ft 8 in)
D: Maximum Dumping Height	(mm)	4790 (15 ft 9 in)	5310 (17 ft 5 in)	4810 (15 ft 9 in)
E: Transport Height	(mm)	2720 (8 ft 11 in)		
F: Overall Transport Length	(mm)	5470 (17 ft 11 in)	6020 (19 ft 9 in)	5480 (17 ft 12 in)
G: Front Attachment Minimum Swing Radius	(mm)	1080 (3 ft 7 in)	1160 (3 ft 10 in)	1080 (3 ft 7 in)
H: Maximum Blade Raise Amount	(mm)	450 (1 ft 6 in)		
I: Maximum Blade Lower Amount	(mm)	230 (9.1 in)		
J: Offset Amount (From Front Attachment Center)	(mm)	Right Offset 1140 (3 ft 9 in) Left Offset 1160 (3 ft 10 in)		
K: Approach Angle	(Deg.)	30		