

Technical Manual

(Operational Principle)

ZAXIS

200 class

200•200LC•210H•210LCH•210•210LC•210N

225 class

225US•225USLC•225USR•225USRLC

230 class

230•230LC•240H•240LCH•250•250LC

270 class

270•270LC•280LC

Excavator

Service Manual (Manual No. KM-178E) consists of the following three separate volumes;

Technical Manual (Operational Principle)	: Vol. No. TO178E
Technical Manual (Troubleshooting)	: Vol. No. TT178E
Workshop Manual	: Vol. No. W178E

HITACHI

INTRODUCTION

TO THE READER

- This manual is written for an experienced technician to provide technical information needed to maintain and repair this machine.
- Be sure to thoroughly read this manual for correct product information and service procedures.
- If you have any questions or comments, at if you found any errors regarding the contents of this manual, please contact using “Service Manual Revision Request Form” at the end of this manual. (Note: Do not tear off the form. Copy it for usage.):
Publications Marketing & Product Support
Hitachi Construction Machinery Co. Ltd.
TEL: 81-298-32-7173
FAX: 81-298-31-1162

ADDITIONAL REFERENCES

- Please refer to the materials listed below in addition to this manual.
 - The Operator’s Manual
 - The Parts Catalog
 - Operation Manual of the Engine
 - Parts Catalog of the Engine
 - Hitachi Training Material

MANUAL COMPOSITION

- This manual consists of three portions: the Technical Manual (Operational Principle), the Technical Manual (Troubleshooting) and the Workshop Manual.
- Information included in the Technical Manual (Operational Principle):
technical information needed for redelivery and delivery, operation and activation of all devices and systems.
- Information included in the Technical Manual (Troubleshooting):
technical information needed for operational performance tests, and troubleshooting procedures.
- Information included in the Workshop Manual:
technical information needed for maintenance and repair of the machine, tools and devices needed for maintenance and repair, maintenance standards, and removal/installation and assemble/disassemble procedures.

INTRODUCTION

PAGE NUMBER

- Each page has a number, located on the center lower part of the page, and each number contains the following information:

Example : T 1-3-5

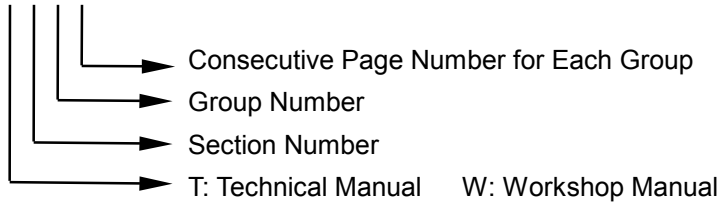

SAFETY ALERT SYMBOL AND HEADLINE NOTATIONS

In this manual, the following safety alert symbol and signal words are used to alert the reader to the potential for personal injury or machine damage.

⚠ This is the safety alert symbol. When you see this symbol, be alert to the potential for personal injury. Never fail to follow the safety instructions prescribed along with the safety alert symbol. The safety alert symbol is also used to draw attention to component/part weights. To avoid injury and damage, be sure to use appropriate lifting techniques and equipment when lifting heavy parts.

- **⚠ CAUTION:**
Indicated potentially hazardous situation which could, if not avoided, result in personal injury or death.
- **IMPORTANT:**
Indicates a situation which, if not conformed to the instructions, could result in damage to the machine.
- **📝 NOTE:**
Indicates supplementary technical information or know-how.

INTRODUCTION

UNITS USED

- SI Units (International System of Units) are used in this manual.

MKSA system units and English units are also indicated in parentheses just behind SI units.

Example : 24.5 MPa (250 kgf/cm², 3560 psi)

A table for conversion from SI units to other system units is shown below for reference purposes.

Quantity	To Convert From	Into	Multiply By	Quantity	To Convert From	Into	Multiply By
Length	mm	in	0.03937	Pressure	MPa	kgf/cm ²	10.197
	mm	ft	0.003281		MPa	psi	145.0
Volume	L	US gal	0.2642	Power	kW	PS	1.360
	L	US qt	1.057		kW	HP	1.341
	m ³	yd ³	1.308	Temperature	°C	°F	°C×1.8+32
Weight	kg	lb	2.205	Velocity	km/h	mph	0.6214
Force	N	kgf	0.10197		min ⁻¹	rpm	1.0
	N	lbf	0.2248	Flow rate	L/min	US gpm	0.2642
Torque	N·m	kgf·m	1.0197		mL/rev	cc/rev	1.0
	N·m	lbf·ft	0.7375				

INTRODUCTION

Hitachi machine models are classified into 4 classes and 1 model as shown in the table below. When referring to the texts and/or illustrations indicated with the applicable machine class names in this manual, check that the machine models concerned are included using this table.

Class

ZX200 Class	ZAXIS200, 200LC, 210H, 210LCH, 210, 210LC, 210N
ZX225 Class	ZAXIS225USR, 225USRLC, 225US, 225USLC
ZX230 Class	ZAXIS230, 230LC, 240H, 240LCH, 250, 250LC
ZX270 Class	ZAXIS270, 270LC, 280LC

Model

Std. Model	200, 200LC, 210, 210LC, 210H, 210LCH, 210N, 225USR, 225USRLC, 225US, 225USLC, 230, 230LC, 240H, 240LCH, 250, 250LC, 270, 270LC, 280LC
------------	---------------------------------------------------------------------------------------------------------------------------------------

SECTION AND GROUP CONTENTS

TECHNICAL MANUAL

(Operational Principle)

SECTION 1 GENERAL

Group 1 Specification

Group 2 Component Layout

Group 3 Component Specifications

SECTION 2 SYSTEM

Group 1 Control System

Group 2 Hydraulic System

Group 3 Electrical System

SECTION 3 COMPONENT OPERATION

Group 1 Pump Device

Group 2 Swing Device

Group 3 Control Valve

Group 4 Pilot Valve

Group 5 Travel Device

Group 6 Signal Control Valve

Group 7 Others(Upperstructure)

Group 8 Others(Undercarriage)

TECHNICAL MANUAL (Troubleshooting)

SECTION 4 OPERATIONAL PERFORMANCE TEST

Group 1 Introduction
Group 2 Standard
Group 3 Engine Test
Group 4 Excavator Test
Group 5 Component Test
Group 6 Adjustment

SECTION 5 TROUBLESHOOTING

Group 1 Diagnosing Procedure
Group 2 Component Layout
Group 3 Troubleshooting A
Group 4 Troubleshooting B
Group 5 Troubleshooting C
Group 6 Electrical System Inspection
Group 7 ICX

All information, illustrations and specifications in this manual are based on the latest product information available at the time of publication. The right is reserved to make changes at any time without notice.

WORKSHOP MANUAL

SECTION 1 GENERAL INFORMATION

Group 1 Precautions for Disassembling and Assembling
Group 2 Tightening Torque
Group 3 Painting
Group 4 Bleeding Air from Hydraulic Oil Tank

SECTION 2 UPPERSTRUCTURE

Group 1 Cab
Group 2 Counterweight
Group 3 Main Frame
Group 4 Pump Device
Group 5 Control Valve
Group 6 Swing Device
Group 7 Pilot Valve
Group 8 Pilot Shut-Off Valve
Group 9 Signal Control Valve
Group 10 Solenoid Valve

SECTION 3 UNDERCARRIAGE

Group 1 Swing Bearing
Group 2 Travel Device
Group 3 Center Joint
Group 4 Track Adjuster
Group 5 Front Idler
Group 6 Upper and Lower Roller
Group 7 Track

SECTION 4 FRONT ATTACHMENT

Group 1 Front Attachment
Group 2 Cylinder

SECTION 5 ENGINE

COPYRIGHT(C)2002

Hitachi Construction Machinery Co., Ltd.

Tokyo, Japan

All rights reserved

SECTION 1 GENERAL

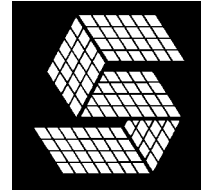

—CONTENTS—

Group 1 Specifications

Specifications	T1-1-1
Working Ranges	T1-1-8

Group 2 Component Layout

Main Component Layout	T1-2-1
Electrical Component Layout	T1-2-4
(Overview)	
Electrical System	T-1-2-7
(Relays and Related Equipment)	
Electrical System	T-1-2-9
(Monitors and Switches)	
Pump Device	T1-2-10
Swing Device	T1-2-10
Control Valve	T1-2-11
Signal Control Valve	T1-2-11
Solenoid Valve Unit	T1-2-11
Travel Device	T1-2-12
Positioning Control Valve	T1-2-12

Group 3 Component Specifications

Engine	T1-3-1
Engine Accessories	T1-3-8
Hydraulic Component	T1-3-9
Electrical Component	T1-3-15

(Blank)

GENERAL / Specifications

SPECIFICATIONS

ZAXIS200, ZAXIS200LC, ZAXIS210H, ZAXIS210LCH

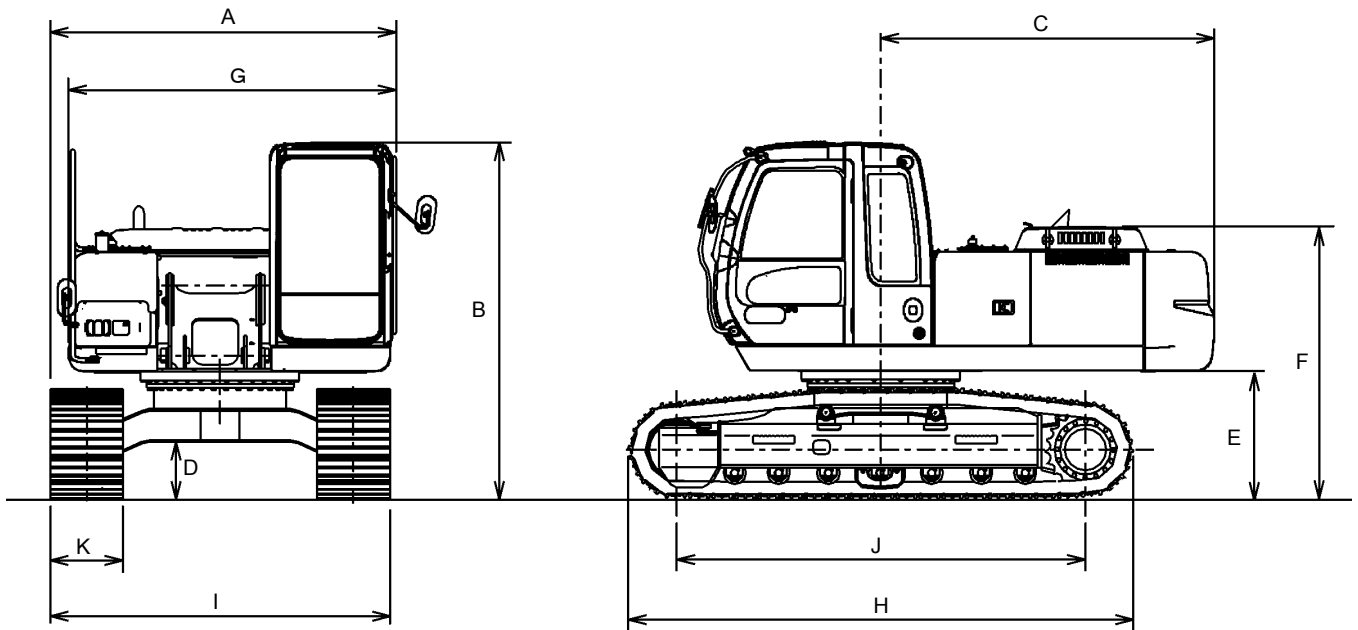

M178-12-001

Model	ZX200 Hydraulic Excavator	ZX200LC Hydraulic Excavator	ZX210H Hydraulic Excavator	ZX210LCH Hydraulic Excavator
Type of Front-End Attachment	2.22 m (7 ft 3 in) Arm or 2.91 m (9 ft 7 in) Arm		2.91 m (9 ft 7 in) H Arm	
Bucket Capacity (Heaped)	PCSA 0.8 m ³ (1.05 yd ³), CECE 0.7 m ³			
Operating Weight	19400 kg (42800 lb)	19900 kg (43900 lb)	20300 kg (44800 lb)	20800 kg (45900 lb)
Basic Machine Weight	15100 kg (33300 lb)	15600 kg (34400 lb)	15800 kg (34800 lb)	16300 kg (35900 lb)
Engine	Isuzu AA-6BG1T 103 kW/1900 min ⁻¹ (140 PS/1900 rpm) * 110 kW / 2100 min ⁻¹ (150 PS /2100 rpm)			
A: Overall Width (Excluding back mirrors)	2860 mm (9 ft 5 in)	2990 mm (9 ft 10 in)	2860 mm (9 ft 5 in)	2990 mm (9 ft 10 in)
B: Cab Height	2950 mm (9 ft 8 in)	2950 mm (9 ft 8 in)	2950 mm (9 ft 8 in)	2950 mm (9 ft 8 in)
C: Rear End Swing Radius	2750 mm (9 ft 0 in)	2750 mm (9 ft 0 in)	2750 mm (9 ft 0 in)	2750 mm (9 ft 0 in)
D: Minimum Ground Clearance	* 450 mm (18 in) (Excluding shoe lug)			
E: Counterweight Clearance	* 1030 mm (3 ft 5 in) (Excluding shoe lug)			
F: Engine Cover Height	* 2220 mm (7 ft 3 in) (Excluding shoe lug)			
G: Overall Width of Upperstructure	2710 mm (8 ft 11 in)	2710 mm (8 ft 11 in)	2710 mm (8 ft 11 in)	2710 mm (8 ft 11 in)
H: Undercarriage Length	4170 mm (13 ft 8 in)	4460 mm (14 ft 8 in)	4170 mm (13 ft 8 in)	4460 mm (14 ft 8 in)
I: Undercarriage Width	2800 mm (9 ft 2 in)	2990 mm (9 ft 10 in)	2800 mm (9 ft 2 in)	2990 mm (9 ft 10 in)
J: Sprocket Center to Idler Center	3370 mm (11 ft 1 in)	3660 mm (12 ft 0 in)	3370 mm (11 ft 1 in)	3660 mm (12 ft 0 in)
K: Track Shoe Width	600 mm (24 in) (Grouser shoe)			
Ground Pressure	43 kPa (0.44 kgf/cm ² , 6.3 psi)	41 kPa (0.42 kgf/cm ² , 6.0 psi)	45 kPa (0.46 kgf/cm ² , 6.5 psi)	43 kPa (0.44 kgf/cm ² , 6.1 psi)
Swing Speed	13.3 min ⁻¹ (rpm)	13.3 min ⁻¹ (rpm)	13.3 min ⁻¹ (rpm)	13.3 min ⁻¹ (rpm)
Travel Speed (fast/slow)	5.5/3.6 km/h (3.4/2.2 mph)			
Gradeability	35° (tanθ = 0.70)			

NOTE: * H/P mode

* The dimensions do not include the height of the shoe lug.

GENERAL / Specifications

ZAXIS210, ZAXIS210LC, ZAXIS210N

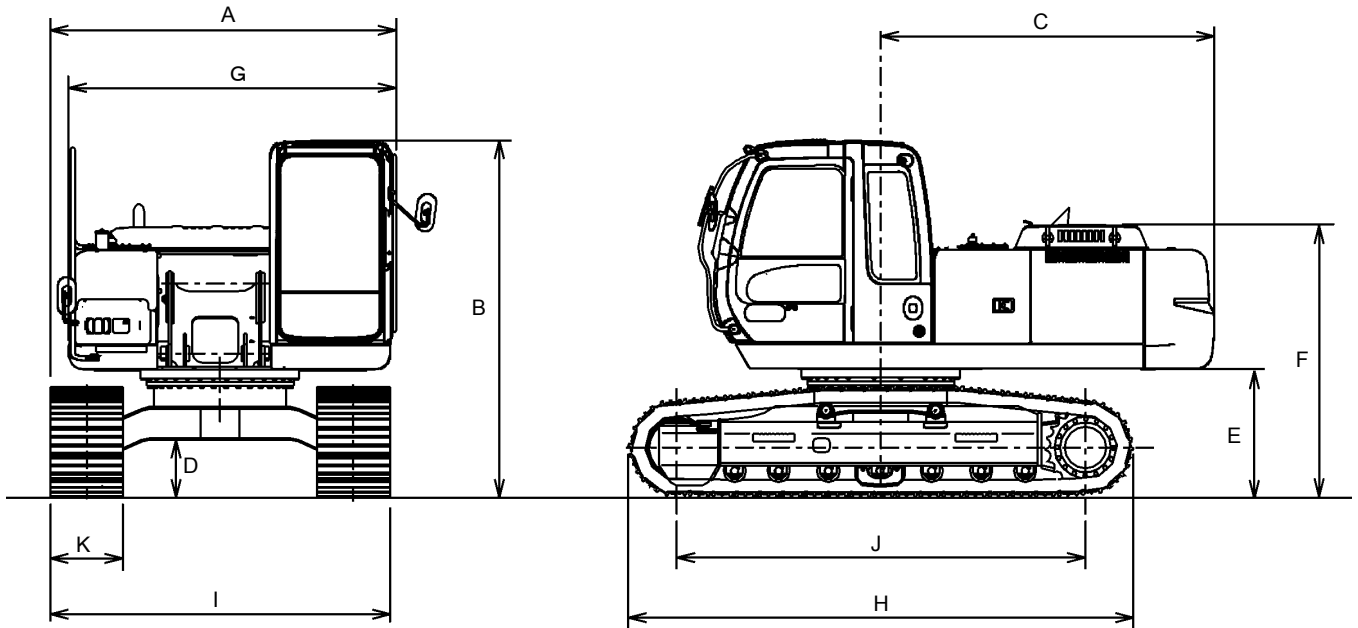

M178-12-001

Model	ZAXIS210	ZAXIS210LC	ZAXIS210N	
Type of Front-End Attachment	2.91 m (9 ft 7 in) Arm			
Bucket Capacity (Heaped)	PCSA 0.8 m ³ (1.05 yd ³), CECE 0.7 m ³			
Operating Weight	19600 kg (43200 lb)	20100 kg (44300 lb)	19500 kg (43000 lb)	19800 kg (43700 lb)
Basic Machine Weight	15200 kg (33500 lb)	15700 kg (34600 lb)	15100 kg (33300 lb)	15400 kg (34000 lb)
Engine	Isuzu AA-6BG1T 103 kW/1900 min ⁻¹ (140 PS/1900 rpm) * 110 kW / 2100 min ⁻¹ (150 PS /2100 rpm)			
A: Overall Width (Excluding back mirrors)	2860 mm (9 ft 5 in)	2990 mm (9 ft 10 in)	2500 mm (8 ft 2 in)	2580 mm (8 ft 6 in)
B: Cab Height	2950 mm (9 ft 8 in)	2950 mm (9 ft 8 in)	2950 mm	
C: Rear End Swing Radius	2750 mm (9 ft 0 in)	2750 mm (9 ft 0 in)	2680 mm (8 ft 10 in)	
D: Minimum Ground Clearance	* 450 mm (18 in) (Excluding shoe lug)			
E: Counterweight Clearance	* 1030 mm (3 ft 5 in) (Excluding shoe lug)			
F: Engine Cover Height	* 2220 mm (7 ft 3 in) (Excluding shoe lug)			
G: Overall Width of Upperstructure	2710 mm (8 ft 11 in)	2710 mm (8 ft 11 in)	2500 mm (8 ft 2 in)	
H: Undercarriage Length	4170 mm (13 ft 8 in)	4460 mm (14 ft 8 in)	4170 mm (13 ft 8 in)	
I: Undercarriage Width	2800 mm (9 ft 2 in)	2990 mm (9 ft 10 in)	2480 mm (8 ft 2 in)	2580 mm (8 ft 6 in)
J: Sprocket Center to Idler Center	3370 mm (11 ft 1 in)	3660 mm (12 ft 0 in)	3370 mm (11 ft 1 in)	
K: Track Shoe Width	600 mm (24 in) (Grouser shoe)		500 mm (20 in) (Grouser shoe)	600 mm (24 in) (Grouser shoe)
Ground Pressure	44 kPa (0.45 kgf/cm ² , 6.4 psi)	42 kPa (0.43 kgf/cm ² , 6.1 psi)	52 kPa (0.53 kgf/cm ² , 7.5 psi)	44 kPa (0.45 kgf/cm ² , 6.4 psi)
Swing Speed	13.3 min ⁻¹ (rpm)			
Travel Speed (fast/slow)	5.5/3.6 km/h (3.4/2.2 mph)			
Gradeability	35° (tanθ = 0.70)			

NOTE: * H/P mode
* The dimensions do not include the height of the shoe lug.

GENERAL / Specifications

ZAXIS225USR, ZAXIS225USRLC

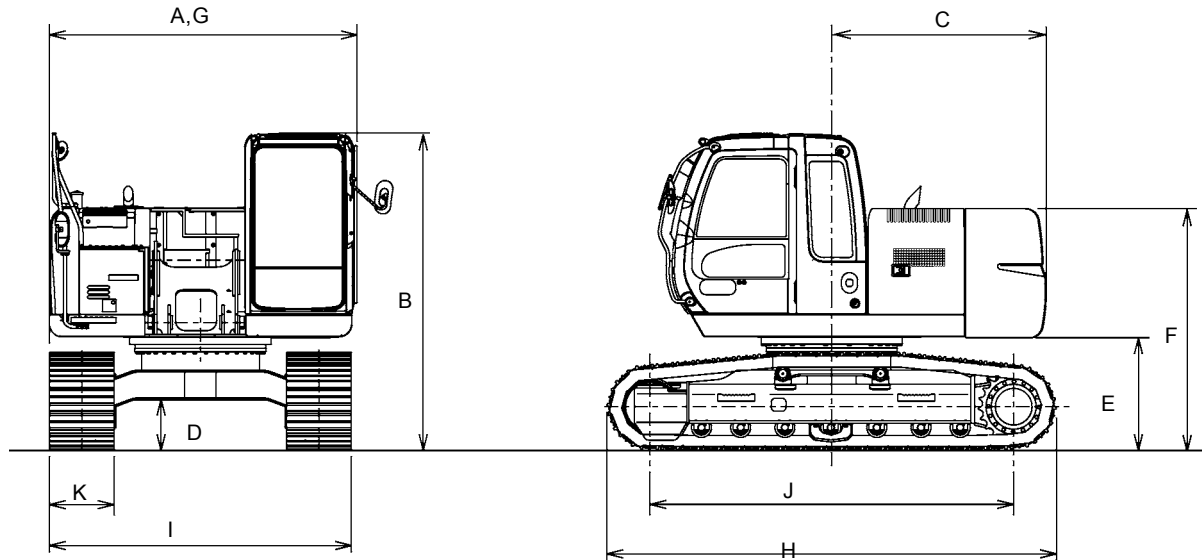

M178-12-007

Model	ZAXIS225USR	ZAXIS225USRLC
Type of Front-End Attachment	2.91 m (9 ft 7 in) Arm	
Bucket Capacity (Heaped)	PCSA 0.8 m ³ (1.05 yd ³), CECE 0.7 m ³	
Operating Weight	22000 kg (48500 lb)	22500 kg (49600 lb)
Basic Machine Weight	17800 kg (39240 lb)	18300 kg (40340 lb)
Engine	Isuzu AA-6BG1T 103 kW/1900 min ⁻¹ (140 PS/1900 rpm) *110 kW/2100 min ⁻¹ (150 PS/2100 rpm)	
A: Overall Width (Excluding back mirrors)	2860 mm (9 ft 5 in)	2990 mm (9 ft 10 in)
B: Cab Height	2950 mm (9 ft 8 in)	
C: Rear End Swing Radius	1990 mm (6 ft 6 in)	
D: Minimum Ground Clearance	*450 mm (18 in)	
E: Counterweight Clearance	* 1020 mm (3 ft 4 in)	
F: Engine Cover Height	* 2220 mm (7 ft 3 in)	
G: Overall Width of Upperstructure	2860 mm (9 ft 5 in)	
H: Undercarriage Length	4170 mm (13 ft 8 in)	4460 mm (14 ft 8 in)
I: Undercarriage Width	2800 mm (9 ft 2 in)	2990 mm (9 ft 10 in)
J: Sprocket Center to Idler Center	3370 mm (11 ft 1 in)	3660 mm (12 ft)
K: Track Shoe Width	600 mm (24 in) (Grouser shoe)	
Ground Pressure	49 kPa (0.50 kgf/cm ² , 7.1 psi)	47 kPa (0.48 kgf/cm ² , 6.8 psi)
Swing Speed	13.3 min ⁻¹ (rpm)	
Travel Speed (fast/slow)	5.3/13.3 km/h (3.3/2.1 mph)	
Gradeability	35° (tanθ = 0.70)	

NOTE: * H/P mode

* The dimensions do not include the height of the shoe lug.

GENERAL / Specifications

ZAXIS225US, ZAXIS225USLC

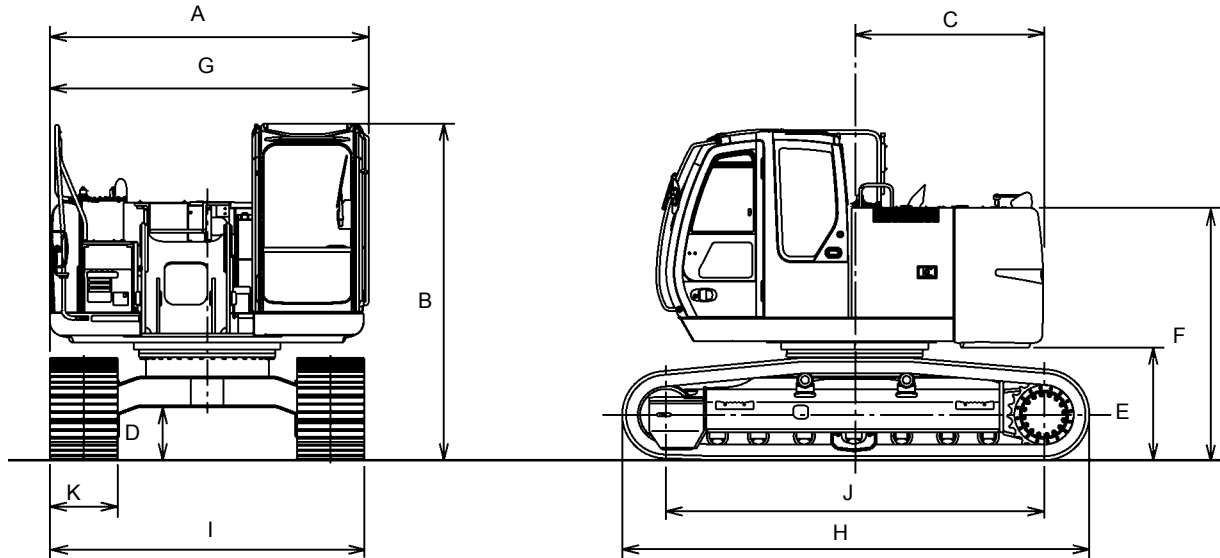

M1GF-12-001

Model	ZAXIS225US	ZAXIS225USLC
Type of Front-End Attachment	2.91 m (9 ft 7 in) Arm	
Bucket Capacity (Heaped)	PCSA 0.8 m ³ (1.05 yd ³), CECE 0.7 m ³	
Operating Weight	23000 kg (50710 lb)	23500 kg (51810 lb)
Basic Machine Weight	18800 kg (41450 lb)	19300 kg (42550 lb)
Engine	Isuzu AA-6BG1T 103 kW/1900 min ⁻¹ (140 PS/1900 rpm) *110 kW/2100 min ⁻¹ (150 PS/2100 rpm)	
A: Overall Width (Excluding back mirrors)	2810 mm (9 ft 3 in)	2990 mm (9 ft 10 in)
B: Cab Height	2950 mm (9 ft 8 in)	
C: Rear End Swing Radius	1680 mm (5 ft 6 in)	
D: Minimum Ground Clearance	*450 mm (18 in)	
E: Counterweight Clearance	*980 mm (3 ft 3 in)	
F: Engine Cover Height	*2220 mm (7 ft 3 in)	
G: Overall Width of Upperstructure	2810 mm (9 ft 3 in)	
H: Undercarriage Length	4170 mm (13 ft 8 in)	4460 mm (14 ft 8 in)
I: Undercarriage Width	2800 mm (9 ft 2 in)	2990 mm (9 ft 10 in)
J: Sprocket Center to Idler Center	3370 mm (11 ft 1 in)	3660 mm (12 ft)
K: Track Shoe Width	600 mm (24 in) (Grouser shoe)	
Ground Pressure	52 kPa (0.53 kgf/cm ² , 7.5 psi)	49 kPa (0.50 kgf/cm ² , 7.1 psi)
Swing Speed	13.3 min ⁻¹ (rpm)	
Travel Speed (fast/slow)	5.3/3.3 km/h (3.3/2.1 mph)	
Gradeability	35° (tanθ = 0.70)	

NOTE: * H/P mode

* The dimensions do not include the height of the shoe lug.

GENERAL / Specifications

ZAXIS230, 230LC, 240H, 240LCH, 250, 250LC

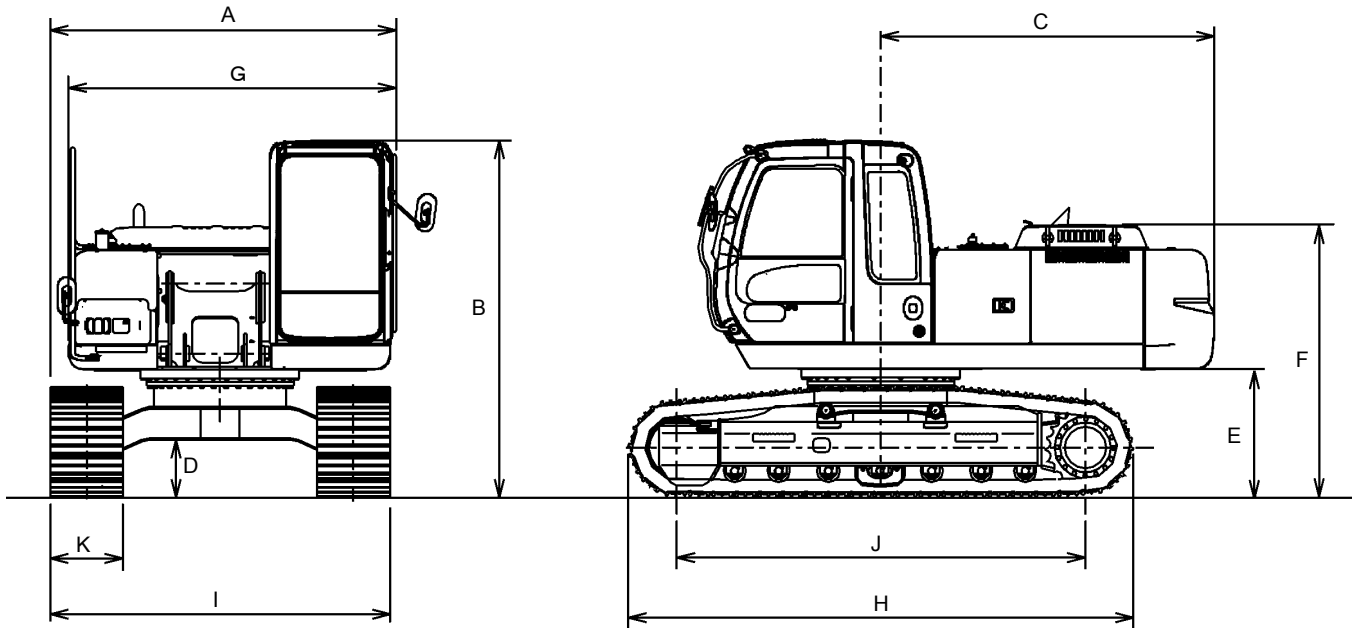

M178-12-001

Model	ZX230, 250 Hydraulic Excavator	ZX230LC, 250LC Hydraulic Excavator	ZX240H Hydraulic Excavator	ZX240LCH Hydraulic Excavator
Type of Front-End Attachment	2.96 m (9 ft 9 in)		2.96 m (9 ft 9 in) H Arm	
Bucket Capacity (Heaped)	PCSA 1.0 m ³ (1.3 yd ³), CECE 0.9 m ³			
Operating Weight	23000 kg (50700 lb)	23600 kg (52000 lb)	24300 kg (53600 lb)	24900 kg (54900 lb)
Basic Machine Weight	17500 kg (38600 lb)	18100 kg (39900 lb)	18500 kg (40800 lb)	19100 kg (42100 lb)
Engine	Isuzu CC-6BG1T 118 kW/2000 min ⁻¹ (160 PS/2000 rpm) * 125 kW/2100 min ⁻¹ (170 PS/2100 rpm)			
A: Overall Width (Excluding back mirrors)	2990 mm (9 ft 10 in)	3090 mm (10 ft 2 in)	2990 mm (9 ft 10 in)	3090 mm (10 ft 2 in)
B: Cab Height	3020 mm (9 ft 11 in)			
C: Rear End Swing Radius	2940 mm (9 ft 8 in)			
D: Minimum Ground Clearance	*460 mm (18 in) (Excluding shoe lug)			
E: Counterweight Clearance	* 1090 mm (3 ft 7 in) (Excluding shoe lug)			
F: Engine Cover Height	* 2290 mm (7 ft 6 in) (Excluding shoe lug)			
G: Overall Width of Upperstructure	2890 mm (9 ft 6 in)			
H: Undercarriage Length	4260 mm (13 ft 12 in)	4640 mm (15 ft 3 in)	4260 mm (13 ft 12 in)	4640 mm (15 ft 3 in)
I: Undercarriage Width	2990 mm (9 ft 10 in)	3190 mm (10 ft 6 in)	2990 mm (9 ft 10 in)	3190 mm (10 ft 6 in)
J: Sprocket Center to Idler Center	3460 mm (11 ft 4 in)	3840 mm (12 ft 7 in)	3460 mm (11 ft 4 in)	3845 mm (12 ft 7 in)
K: Track Shoe Width	600 mm (24 in) (Grouser shoe)			
Ground Pressure	50 kPa (0.51 kgf/cm ² , 7.2 psi)	47 kPa (0.48 kgf/cm ² , 6.8 psi)	53 kPa (0.54 kgf/cm ² , 7.7 psi)	49 kPa (0.50 kgf/cm ² , 6.7 psi)
Swing Speed	12.6 min ⁻¹ (rpm)			
Travel Speed (fast/slow)	5.5/3.4 km/h (3.4/2.1 mph)			
Gradeability	35° (tanθ = 0.70)			

NOTE: * H/P mode

* The dimensions do not include the height of the shoe lug.

GENERAL / Specifications

ZAXIS270, ZAXIS270LC, ZAXIS280LC

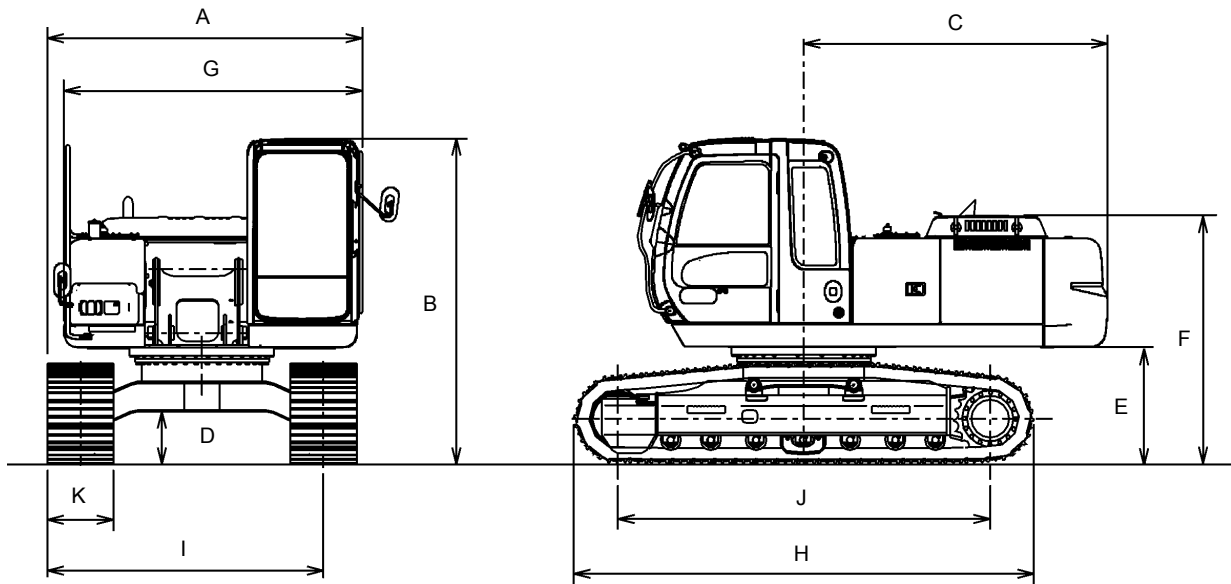

M178-12-001

Model	ZAXIS270	ZAXIS270LC, ZAXIS280LC
Type of Front-End Attachment	3.10 m (10 ft 2 in) Arm	
Bucket Capacity (Heaped)	PCSA 1.1 m ³ (1.44 yd ³), CECE 1.0 m ³	
Operating Weight	27000 kg (59520 lb)	27500 kg (60630 lb)
Basic Machine Weight	21100 kg (46520 lb)	21600 kg (47620 lb)
Engine	Isuzu CC-6BG1T 125 kW/2050 min ⁻¹ (170 PS/2050 rpm) * 132 kW/2150 min ⁻¹ (180 PS/2150 rpm)	
A: Overall Width (Excluding back mirrors)	3090 mm (10 ft 2 in)	
B: Cab Height	3110 mm (10 ft 2 in)	
C: Rear End Swing Radius	2940 mm (9 ft 8 in)	
D: Minimum Ground Clearance	*510 mm (20 in)	
E: Counterweight Clearance	* 1180 mm (3 ft 11 in)	
F: Engine Cover Height	* 2380 mm (7 ft 10 in)	
G: Overall Width of Upperstructure	2890 mm (9 ft 6 in)	
H: Undercarriage Length	4640 mm (15 ft 3 in)	4940 mm (16 ft 3 in)
I: Undercarriage Width	3190 mm (10 ft 6 in)	
J: Sprocket Center to Idler Center	3730 mm (12 ft 3 in)	4050 mm (13 ft 3 in)
K: Track Shoe Width	600 mm (24 in) (Grouser shoe)	
Ground Pressure	55 kPa (0.56 kgf/cm ² , 8.0 psi)	52 kPa (0.53 kgf/cm ² , 7.7 psi)
Swing Speed	10.6 min ⁻¹ (rpm)	
Travel Speed (fast/slow)	4.9/2.9 km/h (3.0/1.8 mph)	
Gradeability	35° (tanθ = 0.70)	

NOTE: * H/P mode

* The dimensions do not include the height of the shoe lug.

GENERAL / Specifications

ZAXIS210, ZAXIS210LC, ZAXIS210N (2-piece Boom)

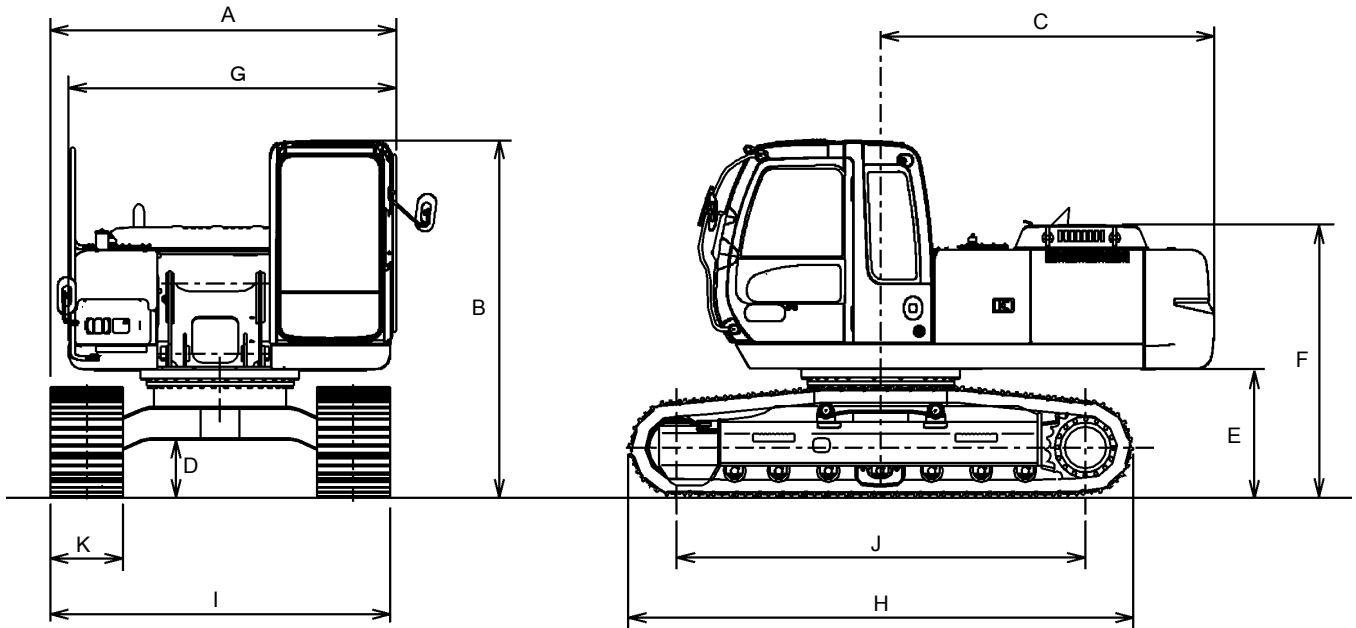

M178-12-001

Model	ZAXIS210 2-piece Boom	ZAXIS210LC 2-piece Boom	ZAXIS210N 2-piece Boom	
Type of Front-End Attachment	2.03 m (6 ft 8 in) Arm			
Bucket Capacity (Heaped)	PCSA 0.8 m ³ (1.05 yd ³), CECE 0.7 m ³			
Operating Weight	19500 kg (44300 lb)	20000 kg (45400 lb)	19500 kg (44100 lb)	19600 kg (44800 lb)
Basic Machine Weight	15200 kg (33500 lb)	15700 kg (34600 lb)	15100 kg (33300 lb)	15400 kg (34000 lb)
Engine	Isuzu AA-6BG1T 103 kW/1900 min ⁻¹ (140 PS/1900 rpm) * 110 kW / 2100 min ⁻¹ (150 PS /2100 rpm)			
A: Overall Width (Excluding back mirrors)	2860 mm (9 ft 5 in)	2990 mm (9 ft 10 in)	2500 mm (8 ft 2 in)	2580 mm (8 ft 6 in)
B: Cab Height	2950 mm (9 ft 8 in)			
C: Rear End Swing Radius	2750 mm (9 ft 0 in)		2680 mm (8 ft 10 in)	
D: Minimum Ground Clearance	* 450 mm (18 in) (Excluding shoe lug)			
E: Counterweight Clearance	* 1030 mm (3 ft 5 in) (Excluding shoe lug)			
F: Engine Cover Height	* 2220 mm (7 ft 3 in) (Excluding shoe lug)			
G: Overall Width of Upperstructure	2710 mm (8 ft 11 in)	2710 mm (8 ft 11 in)	2500 mm (8 ft 2 in)	
H: Undercarriage Length	4170 mm (13 ft 8 in)	4460 mm (14 ft 8 in)	4170 mm (13 ft 8 in)	
I: Undercarriage Width	2800 mm (9 ft 2 in)	2990 mm (9 ft 10 in)	2480 mm (8 ft 2 in)	2580 mm (8 ft 6 in)
J: Sprocket Center to Idler Center	3370 mm (11 ft 1 in)	3660 mm (12 ft 0 in)	3370 mm (11 ft 1 in)	
K: Track Shoe Width	600 mm (24 in) (Grouser shoe)		500 mm (20 in) (Grouser shoe)	600 mm (24 in) (Grouser shoe)
Ground Pressure	45 kPa (0.46 kgf/cm ² , 6.5 psi)	43 kPa (0.44 kgf/cm ² , 6.3 psi)	54 kPa (0.55 kgf/cm ² , 7.8 psi)	45 kPa (0.46 kgf/cm ² , 6.5 psi)
Swing Speed	13.3 min ⁻¹ (rpm)			
Travel Speed (fast/slow)	5.5/3.6 km/h (3.4/2.2 mph)			
Gradeability	35° (tanθ = 0.70)			

NOTE: * H/P mode

* The dimensions do not include the height of the shoe lug.

GENERAL / Specifications

WORKING RANGES

ZAXIS200, ZAXIS200LC, ZAXIS210H, ZAXIS210LCH

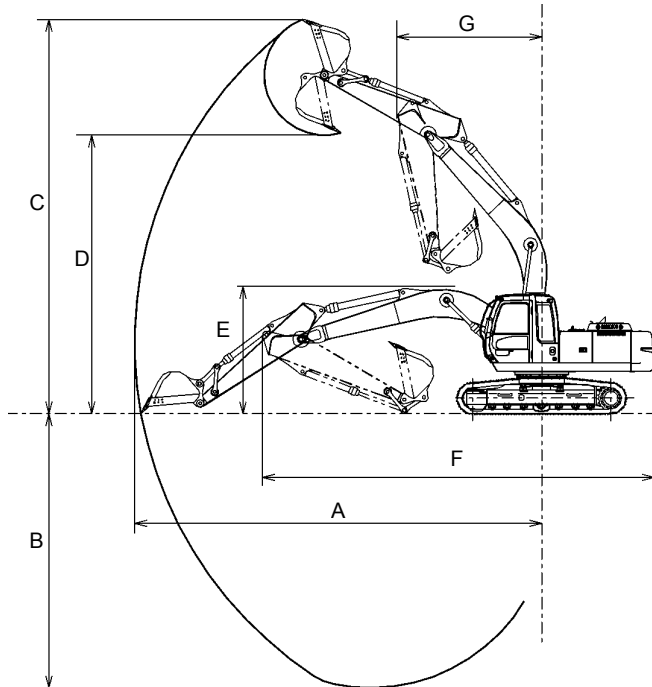

Backhoe

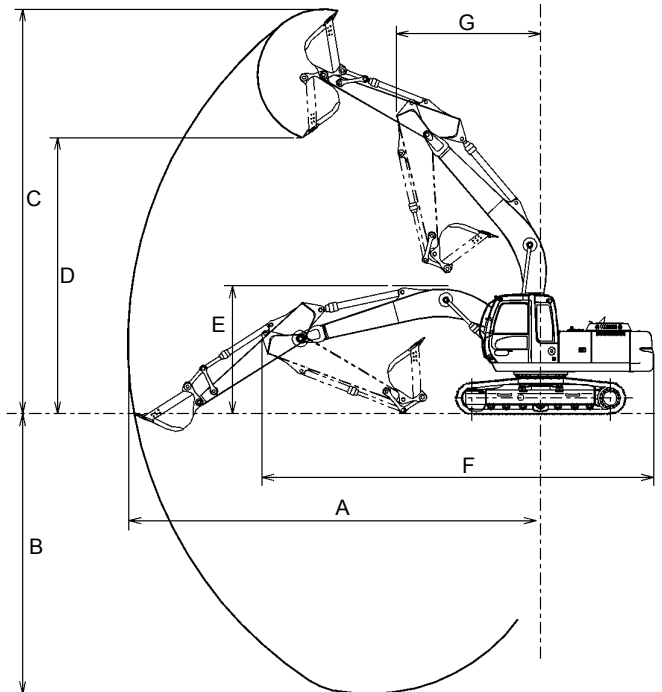

Face shovel (Reversed hoe bucket)

M178-12-002

Model	ZAXIS200, 200LC								ZAXIS210H, 210LCH			
	2.22 m (7 ft 3 in) Arm				2.91 m (9 ft 7 in) Standard Arm				2.91 m (9 ft 7 in) H Arm			
	Backhoe		Shovel		Backhoe		Shovel		Backhoe		Shovel	
Item	mm	ft·in	mm	ft·in	mm	ft·in	mm	ft·in	mm	ft·in	mm	ft·in
A: Maximum Digging Reach	9250	30'4"	9390	30'10"	9910	32'6"	10060	33'0"	9910	32'6"	10060	33'0"
B: Maximum Digging Depth	*5980	*19'7"	*6120	*20'0"	*6670	*21'11"	*6820	*22'5"	*6670	*21'11"	*6820	*22'5"
C: Maximum Cutting Height	*9170	*30'1"	*9450	*31'0"	*9600	*31'6"	*9850	*32'4"	*9600	*31'6"	*9850	*32'4"
D: Maximum Dumping Height	*6390	*21'0"	*6290	*20'8"	*6780	*22'3"	*6720	*22'1"	*6780	*22'3"	*6720	*22'1"
E: Transport Height	3130	10'3"	3130	10'3"	2970	9'9"	2970	9'9"	2970	9'9"	2970	9'9"
F: Overall Transport Length	9620	31'7"	9620	31'7"	9500	31'2"	9500	31'2"	9500	31'2"	9500	31'2"
G: Minimum Swing Radius	3530	11'7"	3530	11'7"	3540	11'7"	3540	11'7"	3540	11'7"	3540	11'7"

NOTE: * The dimensions do not include the height of the shoe lug.

GENERAL / Specifications

ZAXIS210, ZAXIS210LC, ZAXIS210N

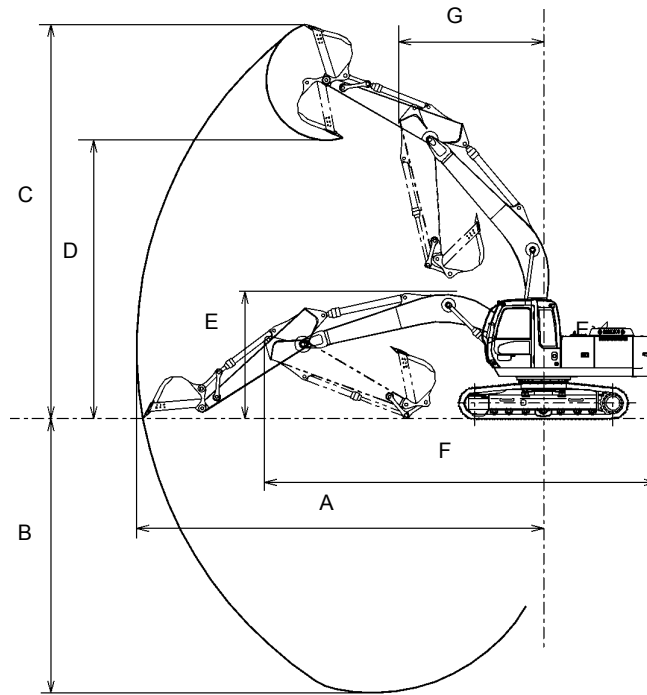

Backhoe

M178-12-002

Item	Category	2.03 m (6 ft 8 in) Arm		2.42 m (7 ft 11in) Arm		2.91 m (9 ft 7 in) Arm		3.51 m (11 ft 6 in) Arm	
		Backhoe		Backhoe		Backhoe		Backhoe	
		mm	ft·in	mm	ft·in	mm	ft·in	mm	ft·in
A: Maximum Digging Reach		9215	30'3"	9415	30'11"	9910	32'6"	10445	34'3"
B: Maximum Digging Depth		*5790	*18'12"	*6175	*20'3"	*6670	*21'11"	*7265	*23'10"
C: Maximum Cutting Height		*9475	*31'1"	*9245	*30'4"	*9600	*31'6"	*9855	*32'4"
D: Maximum Dumping Height		*6610	*21'8"	*6460	*21'2"	*6780	*22'3"	*7035	*23'1"
E: Transport Height		3120	10'3"	3150	10'4"	2970	9'9"	3110	10'2"
F: Overall Transport Length		9620	31'7"	9610	31'6"	9500	31'2"	9560	31'4"
G: Minimum Swing Radius		3605	11'10"	3525	11'7"	3540	11'7"	3555	11'8"

NOTE: * The dimensions do not include the height of the shoe lug.

GENERAL / Specifications

ZAXIS225USR, ZAXIS225USRLC

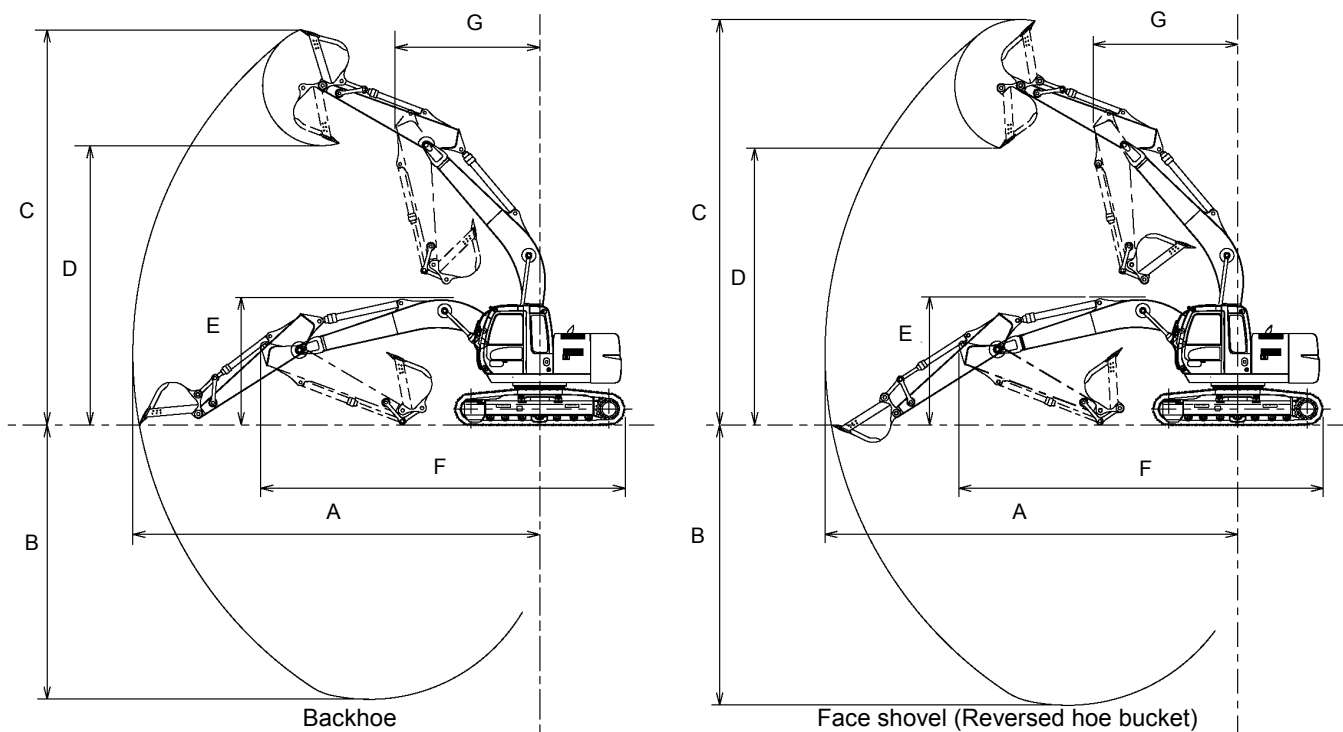

M178-12-009

Item	Category	2.22 m (7 ft 3 in) Arm				2.91 m (9 ft 7 in) Standard Arm			
		Backhoe		Shovel		Backhoe		Shovel	
		mm	ft-in	mm	ft-in	mm	ft-in	mm	ft-in
A: Maximum Digging Reach		9250	30' 4"	9390	30' 10"	9910	32' 6"	10060	33' 0"
B: Maximum Digging Depth		* ¹ 5980	* ¹ 19' 7"	* ¹ 6120	* ¹ 20' 1"	* ¹ 6670	* ¹ 21' 11"	* ¹ 6820	* ¹ 22' 5"
C: Maximum Cutting Height		* ¹ 9170	* ¹ 30' 1"	* ¹ 9450	* ¹ 31' 0"	* ¹ 9600	* ¹ 31' 6"	* ¹ 9850	* ¹ 32' 4"
D: Maximum Dumping Height		* ¹ 6390	* ¹ 21' 0"	* ¹ 6290	* ¹ 20' 8"	* ¹ 6780	* ¹ 22' 3"	* ¹ 6720	* ¹ 22' 1"
E: Transport Height		3130	10' 3"	3130	10' 3"	2970	9' 9"	2970	9' 9"
F: Overall Transport Length		* ² 8985	* ² 29' 6"	* ² 8985	* ² 29' 6"	* ² 8865	* ² 29' 1"	* ² 8865	* ² 29' 1"
		* ³ 9130	* ³ 29' 11"	* ³ 9130	* ³ 29' 11"	* ³ 9010	* ³ 29' 7"	* ³ 9010	* ³ 29' 7"
G: Minimum Swing Radius		3530	11' 7"	3530	11' 7"	3540	11' 7"	3540	11' 7"

NOTE: *¹ The dimensions do not include the height of the shoe lug.

*² ZAXIS225USR

*³ ZAXIS225USRLC