

Technical Manual

Operational Principle

ZX

210W-3

220W-3

Wheeled Excavator

Service Manual consists of the following separate Part No;

Technical Manual (Operational Principle) : Vol. No.TOCJB-E-SP

Technical Manual (Troubleshooting) : Vol. No.TTCJB-E-SP

Workshop Manual : Vol. No.WCJB-E-SP

INTRODUCTION

TO THE READER

- This manual is written for an experienced technician to provide technical information needed to maintain and repair this machine.
- Be sure to thoroughly read this manual for correct product information and service procedures.
- If you have any questions or comments, or if you found any errors regarding the contents of this manual, please contact using "Service Manual Revision Request Form" at the end of this manual.
(Note: Do not tear off the form. Copy it for use.)
Publications Marketing & Product Support
Hitachi Construction Machinery Co. Ltd.
TEL: 81-29-832-7084
FAX: 81-29-831-1162
E-mail: dc@hitachi-kenki.com

ADDITIONAL REFERENCES

- Please refer to the other materials (operator's manual, parts catalog, engine technical material and Hitachi training material etc.) in addition to this manual.

MANUAL COMPOSITION

- This manual consists of the Technical Manual and the Workshop Manual.
- Information included in the Technical Manual: technical information needed for redelivery and delivery, operation and activation of all devices and systems, operational performance tests, and troubleshooting procedures.
- Information included in the Workshop Manual: technical information needed for maintenance and repair of the machine, tools and devices needed for maintenance and repair, maintenance standards, and removal/installation and assemble/disassemble procedures.

PAGE NUMBER

- Each page has a number, located on the center lower part of the page, and each number contains the following information:

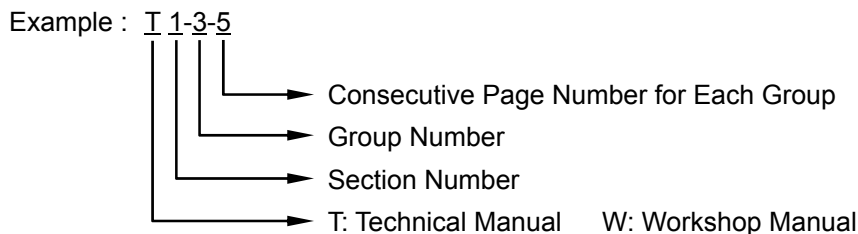

INTRODUCTION

SAFETY ALERT SYMBOL AND HEADLINE NOTATIONS

In this manual, the following safety alert symbol and signal words are used to alert the reader to the potential for personal injury or machine damage.

 This is the safety alert symbol. When you see this symbol, be alert to the potential for personal injury. Never fail to follow the safety instructions prescribed along with the safety alert symbol.

The safety alert symbol is also used to draw attention to component/part weights.

To avoid injury and damage, be sure to use appropriate lifting techniques and equipment when lifting heavy parts.

-  **CAUTION:**
Indicated potentially hazardous situation which could, if not avoided, result in personal injury or death.

- **IMPORTANT:**
Indicates a situation which, if not conformed to the instructions, could result in damage to the machine.

-  **NOTE:**
Indicates supplementary technical information or know-how.

UNITS USED

- SI Units (International System of Units) are used in this manual. MKSA system units and English units are also indicated in parentheses just behind SI units.

Example : 24.5 MPa (250 kgf/cm², 3560 psi)

A table for conversion from SI units to other system units is shown below for reference purposes.

Quantity	To Convert From	Into	Multiply By	Quantity	To Convert From	Into	Multiply By
Length	mm	in	0.03937	Pressure	MPa	kgf/cm ²	10.197
	mm	ft	0.003281		MPa	psi	145.0
Volume	L	US gal	0.2642	Power	kW	PS	1.360
	L	US qt	1.057		kW	HP	1.341
	m ³	yd ³	1.308	Temperature	°C	°F	°C×1.8+32
Weight	kg	lb	2.205	Velocity	km/h	mph	0.6214
Force	N	kgf	0.10197		min ⁻¹	rpm	1.0
	N	lbf	0.2248	Flow rate	L/min	US gpm	0.2642
Torque	N·m	kgf·m	1.0197		mL/rev	cc/rev	1.0
	N·m	lbf·ft	0.7375				

SECTION AND GROUP CONTENTS

TECHNICAL MANUAL

(Operational Principle)

All information, illustrations and specifications in this manual are based on the latest product information available at the time of publication. The right is reserved to make changes at any time without notice.

COPYRIGHT(C)2008
Hitachi Construction Machinery Co., Ltd.
Tokyo, Japan
All rights reserved

SECTION 1 GENERAL

Group 1 Specification
Group 2 Component Layout
Group 3 Component Specifications

SECTION 2 SYSTEM

Group 1 Controller
Group 2 Control System
Group 3 ECM System
Group 4 Hydraulic System
Group 5 Electrical System

SECTION 3 COMPONENT OPERATION

Group 1 Pump Device
Group 2 Swing Device
Group 3 Control Valve
Group 4 Pilot Valve
Group 5 Electric Lever
Group 6 Transmission
Group 7 Axle
Group 8 Travel Motor
Group 9 Signal Control Valve
Group 10 Steering Valve
Group 11 Brake Valve
Group 12 Others (Upperstructure)
Group 13 Others (Undercarriage)

TECHNICAL MANUAL (Troubleshooting)

SECTION 4 OPERATIONAL PERFORMANCE TEST

Group 1 Introduction
Group 2 Standard
Group 3 Engine Test
Group 4 Excavator Test
Group 5 Component Test

SECTION 5 TROUBLESHOOTING

Group 1 Diagnosing Procedure
Group 2 Monitor Unit
Group 3 Dr. ZX
Group 4 ICF
Group 5 Component Layout
Group 6 Troubleshooting A
Group 7 Troubleshooting B
Group 8 Electrical System Inspection

WORKSHOP MANUAL

SECTION 1 GENERAL INFORMATION

- Group 1 Precautions for Disassembling and Assembling
- Group 2 Tightening Torque
- Group 3 Painting
- Group 4 Bleeding Air from Hydraulic Oil Tank

SECTION 2 UPPERSTRUCTURE

- Group 1 Cab
- Group 2 Counterweight
- Group 3 Main Frame
- Group 4 Pump Device
- Group 5 Control Valve
- Group 6 Swing Device
- Group 7 Pilot Valve
- Group 8 Electric Lever
- Group 9 Pilot Shut-Off Solenoid Valve
- Group 10 Signal Control Valve
- Group 11 Travel Shockless Valve
- Group 12 Solenoid Valve
- Group 13 Steering Valve
- Group 14 Brake Valve
- Group 15 Accumulator Charging Valve

SECTION 3 UNDERCARRIAGE

- Group 1 Swing Bearing
- Group 2 Travel Motor
- Group 3 Center Joint
- Group 4 Transmission
- Group 5 Axle
- Group 6 Axle Lock Cylinder
- Group 7 Operate Check Valve (Axle Lock Cylinder)

SECTION 4 FRONT ATTACHMENT

- Group 1 Front Attachment
 - Group 2 Cylinder
 - Group 3 Hose Rupture Valve
 - Group 4 Operate Check Valve (Blade/Outrigger)
-

SECTION 1 GENERAL

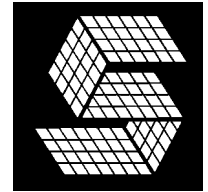

CONTENTS

Group 1 Specifications

Specifications	T1-1-1
Working Ranges	T1-1-6

Group 2 Component Layout

Main Component Layout.....	T1-2-1
Electrical System (Overview).....	T1-2-5
Electrical System (Monitors and Switches)	T1-2-7
Electrical System (Controllers and Relays).....	T1-2-10
Engine	T1-2-12
Pump Device	T1-2-13
Swing Device.....	T1-2-13
Signal Control Valve	T1-2-13
Control Valve	T1-2-14
Brake Valve	T1-2-14
4-Spool Solenoid Valve Unit	T1-2-14
Solenoid Valve Unit (for Electric Lever) ..	T1-2-14
Travel Shockless Valve.....	T1-2-15
Transmission Changeover Solenoid Valve.....	T1-2-15
Travel Device.....	T1-2-15
Filter	T1-2-15

Group 3 Component Specifications

Engine	T1-3-1
Engine Accessories	T1-3-5
Hydraulic Component	T1-3-7
Electrical Component.....	T1-3-13

(Blank)

GENERAL / Specifications

SPECIFICATIONS

ZX210W-3 (Standard GAUGE, REAR BLADE)

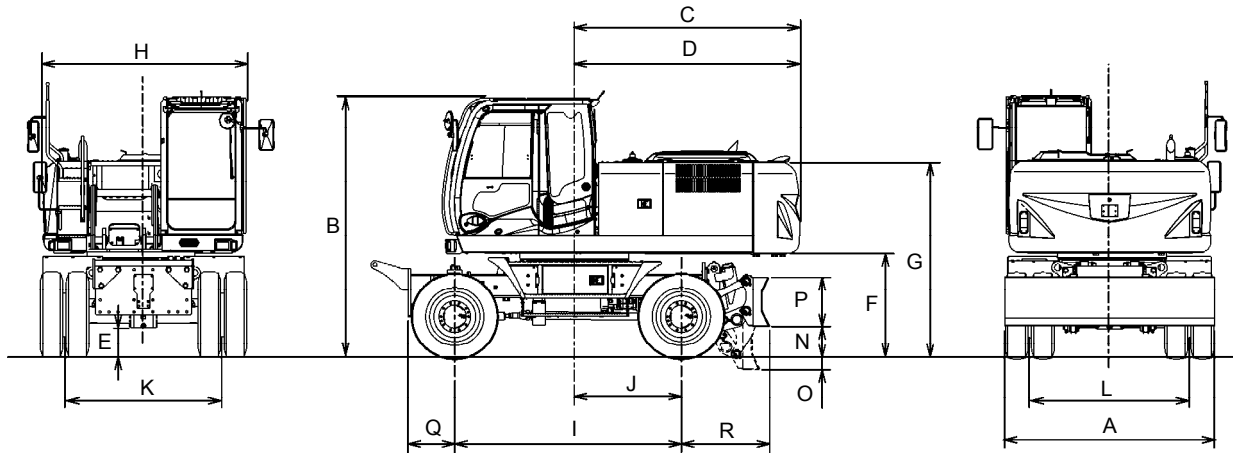

MCGB-12-022

Type of Front-End Attachment		Monoblock Boom	2-Piece Boom
Type of Arm		2.91m (9 ft 7 in)	2.41m (7 ft 11 in)
Bucket Capacity (Heaped)		PCSA 0.80 m ³ (1.05 yd ³), CECE 0.70 m ³	
Operating Weight	kg (lb)	19800 (43700)	20700 (45600)
Basic Machine Weight	kg (lb)	16000 (35300)	16000 (35300)
Engine		ISUZU AI-4HK1X	
Engine Power	SAE J1349 net	122 kW/2000 min ⁻¹ (166 PS/2000 rpm)	
	ISO 9249 net		
	EEC 80/1269 net		
A: Overall Width (Excluding Rearview Mirrors)	mm (ft·in)	2530 (8' 4")	
B: Cab Height	mm (ft·in)	3170 (10' 5")	
C: Rear End Swing Radius	mm (ft·in)	2750 (9' 0")	
D: Rear End Length	mm (ft·in)	2750 (9' 0")	
E: Minimum Ground Clearance	mm (ft·in)	325 (1' 1")	
F: Counterweight Clearance	mm (ft·in)	1230 (4' 0")	
G: Engine Cover Height	mm (ft·in)	2520 (8' 3")	
H: Overall Width of Upperstructure	mm (ft·in)	2470 (8' 1")	
I: Wheelbase	mm (ft·in)	2750 (9' 0")	
J: Swing-Center to Rear Axle	mm (ft·in)	1300 (4' 3")	
K: Front Wheel Tread	mm (ft·in)	1915 (6' 3")	
L: Rear Wheel Tread	mm (ft·in)	1915 (6' 3")	
M: Outrigger Spread	mm (ft·in)	-	
N: Max. Raising Height	mm (ft·in)	375 (1' 3")	
O: Max. Digging Depth	mm (ft·in)	215 (8")	
P: Blade Height	mm (ft·in)	600 (2' 0")	
Q: Front Axle to Front of Chassis	mm (ft·in)	605 (2' 0")	
R: Rear Axle to Rear of Chassis	mm (ft·in)	1075 (3' 6")	
Tire Size		10.00-20 16PR	
Swing Speed	min ⁻¹ (rpm)	12.2	
Travel Speed (Fast / Slow / Creeper) *	km/h (mph)	27.5/7.4/2.9 (17.1/4.6/1.8)	
Gradeability	Degree (%)	35 (70)	

NOTE: "*" The specification not matching the local regulation is excluded.

GENERAL / Specifications

ZX210W-3 (Standard GAUGE, REAR OUTRIGGER)

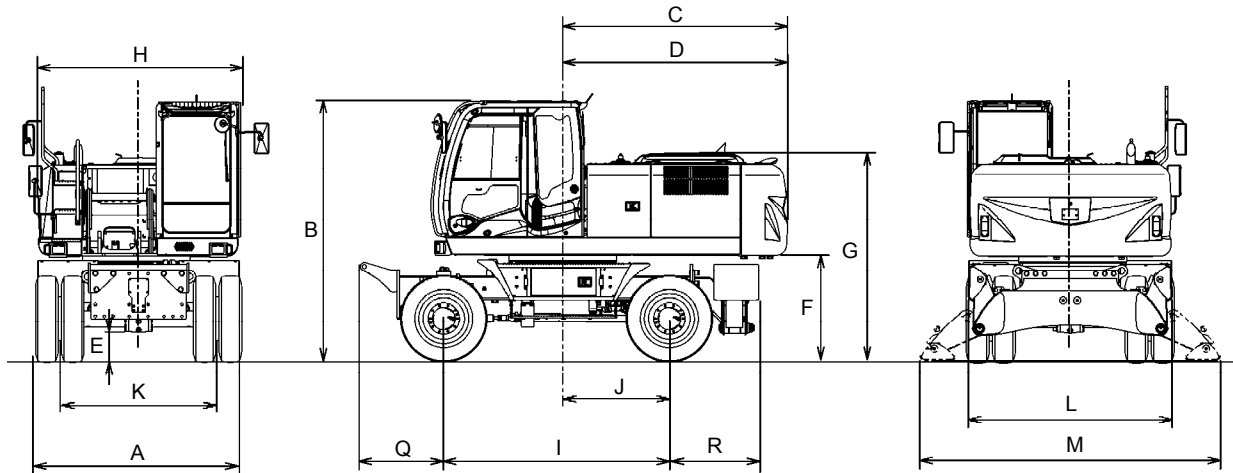

MCGB-12-023

Type of Front-End Attachment		Monoblock Boom	2-Piece Boom
Type of Arm		2.91m (9 ft 7 in)	2.41m (7 ft 11 in)
Bucket Capacity (Heaped)		PCSA 0.80 m ³ (1.05 yd ³), CECE 0.70 m ³	
Operating Weight	kg (lb)	19900 (43900)	20700 (45600)
Basic Machine Weight	kg (lb)	16100 (35500)	16100 (35500)
Engine		ISUZU AI-4HK1X	
Engine Power	SAE J1349 net ISO 9249 net EEC 80/1269 net	122 kW/2000 min ⁻¹ (166 PS/2000 rpm)	
A: Overall Width (Excluding Rearview Mirrors)	mm (ft-in)	2530 (8' 4")	
B: Cab Height	mm (ft-in)	3170 (10' 5")	
C: Rear End Swing Radius	mm (ft-in)	2750 (9' 0")	
D: Rear End Length	mm (ft-in)	2750 (9' 0")	
E: Minimum Ground Clearance	mm (ft-in)	325 (1' 1")	
F: Counterweight Clearance	mm (ft-in)	1230 (4' 0")	
G: Engine Cover Height	mm (ft-in)	2520 (8' 3")	
H: Overall Width of Upperstructure	mm (ft-in)	2470 (8' 1")	
I: Wheelbase	mm (ft-in)	2750 (9' 0")	
J: Swing-Center to Rear Axle	mm (ft-in)	1300 (4' 3")	
K: Front Wheel Tread	mm (ft-in)	1915 (6' 3")	
L: Rear Wheel Tread	mm (ft-in)	1915 (6' 3")	
M: Outrigger Spread	mm (ft-in)	3440 (11' 3")	
N: Max. Raising Height	mm (ft-in)	-	
O: Max. Digging Depth	mm (ft-in)	-	
P: Blade Height	mm (ft-in)	-	
Q: Front Axle to Front of Chassis	mm (ft-in)	605 (2' 0")	
R: Rear Axle to Rear of Chassis	mm (ft-in)	1090 (3' 7")	
Tire Size		10.00-20 16PR	
Swing Speed	min ⁻¹ (rpm)	12.2	
Travel Speed (Fast / Slow / Creeper) *	km/h (mph)	27.5/7.4/2.9 (17.1/4.6/1.8)	
Gradeability	Degree (%)	35 (70)	

NOTE: "*" The specification not matching the local regulation is excluded.

GENERAL / Specifications

ZX210W-3 (Standard GAUGE, FRONT BLADE REAR OUTRIGGER)

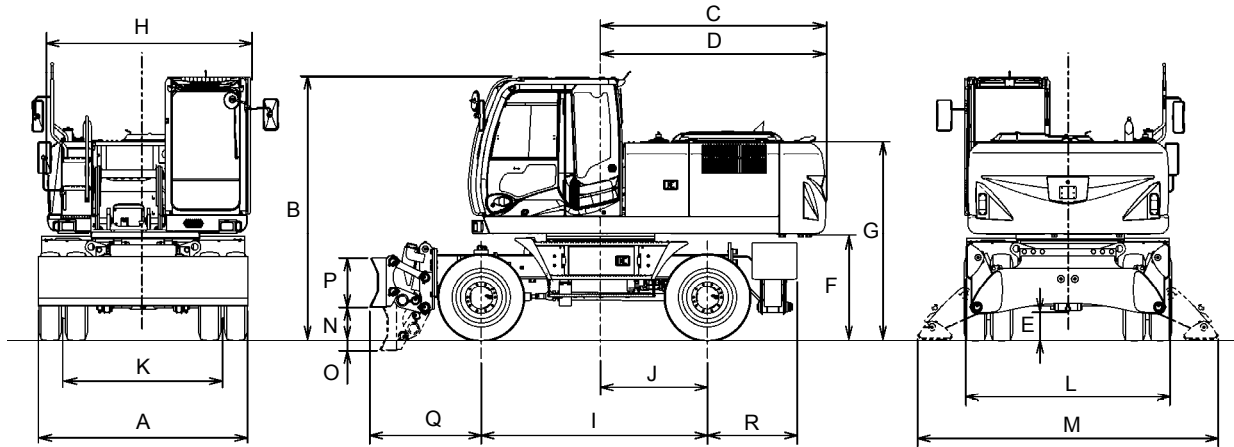

MCGB-12-024

Type of Front-End Attachment		Monoblock Boom	2-Piece Boom
Type of Arm		2.91m (9 ft 7 in)	2.41m (7 ft 11 in)
Bucket Capacity (Heaped)		PCSA 0.80 m ³ (1.05 yd ³), CECE 0.70 m ³	
Operating Weight		20800 (45900) kg (lb)	21700 (47800) kg (lb)
Basic Machine Weight		17000 (37500) kg (lb)	17000 (37500) kg (lb)
Engine		ISUZU AI-4HK1X	
Engine Power		122 kW/2000 min ⁻¹ (166 PS/2000 rpm)	
		SAE J1349 net	
		ISO 9249 net	
		EEC 80/1269 net	
A: Overall Width (Excluding Rearview Mirrors)		mm (ft-in)	2530 (8' 4")
B: Cab Height		mm (ft-in)	3170 (10' 5")
C: Rear End Swing Radius		mm (ft-in)	2750 (9' 0")
D: Rear End Length		mm (ft-in)	2750 (9' 0")
E: Minimum Ground Clearance		mm (ft-in)	325 (1' 1")
F: Counterweight Clearance		mm (ft-in)	1230 (4' 0")
G: Engine Cover Height		mm (ft-in)	2520 (8' 3")
H: Overall Width of Upperstructure		mm (ft-in)	2470 (8' 1")
I: Wheelbase		mm (ft-in)	2750 (9' 0")
J: Swing-Center to Rear Axle		mm (ft-in)	1300 (4' 3")
K: Front Wheel Tread		mm (ft-in)	1915 (6' 3")
L: Rear Wheel Tread		mm (ft-in)	1915 (6' 3")
M: Outrigger Spread		mm (ft-in)	3440 (11' 3")
N: Max. Raising Height		mm (ft-in)	375 (1' 3")
O: Max. Digging Depth		mm (ft-in)	215 (8")
P: Blade Height		mm (ft-in)	600 (2' 0")
Q: Front Axle to Front of Chassis		mm (ft-in)	1355 (4' 5")
R: Rear Axle to Rear of Chassis		mm (ft-in)	1090 (3' 7")
Tire Size		10.00-20 16PR	
Swing Speed		min ⁻¹ (rpm)	12.2
Travel Speed (Fast / Slow / Creeper) *		km/h (mph)	27.5/7.4/2.9 (17.1/4.6/1.8)
Gradeability		Degree (%)	35 (70)

NOTE: “**” The specification not matching the local regulation is excluded.

GENERAL / Specifications

ZX210W-3 (Standard GAUGE, FRONT OUTRIGGER REAR BLADE)

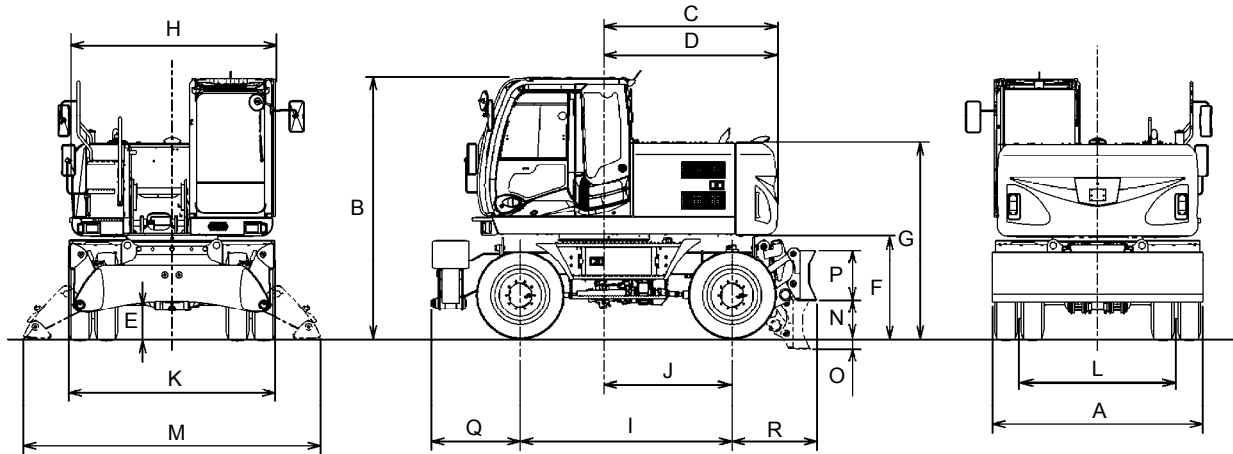

MCGB-12-025

Type of Front-End Attachment		Monoblock Boom	2-Piece Boom
Type of Arm		2.91m (9 ft 7 in)	2.41m (7 ft 11 in)
Bucket Capacity (Heaped)		PCSA 0.80 m ³ (1.05 yd ³), CECE 0.70 m ³	
Operating Weight		kg (lb)	20800 (45900)
Basic Machine Weight		kg (lb)	17000 (37500)
Engine		ISUZU AI-4HK1X	
Engine Power		SAE J1349 net	122 kW/2000 min ⁻¹ (166 PS/2000 rpm)
		ISO 9249 net	
		EEC 80/1269 net	
A: Overall Width (Excluding Rearview Mirrors)	mm (ft-in)	2530 (8' 4")	
B: Cab Height	mm (ft-in)	3170 (10' 5")	
C: Rear End Swing Radius	mm (ft-in)	2750 (9' 0")	
D: Rear End Length	mm (ft-in)	2750 (9' 0")	
E: Minimum Ground Clearance	mm (ft-in)	325 (1' 1")	
F: Counterweight Clearance	mm (ft-in)	1230 (4' 0")	
G: Engine Cover Height	mm (ft-in)	2520 (8' 3")	
H: Overall Width of Upperstructure	mm (ft-in)	2470 (8' 1")	
I: Wheelbase	mm (ft-in)	2750 (9' 0")	
J: Swing-Center to Rear Axle	mm (ft-in)	1300 (4' 3")	
K: Front Wheel Tread	mm (ft-in)	1915 (6' 3")	
L: Rear Wheel Tread	mm (ft-in)	1915 (6' 3")	
M: Outrigger Spread	mm (ft-in)	3440 (11' 3")	
N: Max. Raising Height	mm (ft-in)	375 (1' 3")	
O: Max. Digging Depth	mm (ft-in)	215 (8")	
P: Blade Height	mm (ft-in)	600 (2' 0")	
Q: Front Axle to Front of Chassis	mm (ft-in)	1375 (4' 6")	
R: Rear Axle to Rear of Chassis	mm (ft-in)	1075 (3' 6")	
Tire Size		10.00-20 16PR	
Swing Speed		min ⁻¹ (rpm)	12.2
Travel Speed (Fast / Slow / Creeper) *		km/h (mph)	27.5/7.4/2.9 (17.1/4.6/1.8)
Gradeability		Degree (%)	35 (70)

NOTE: "*" The specification not matching the local regulation is excluded.

GENERAL / Specifications

ZX210W-3 (Standard GAUGE, FRONT OUTRIGGER REAR OUTRIGGER)

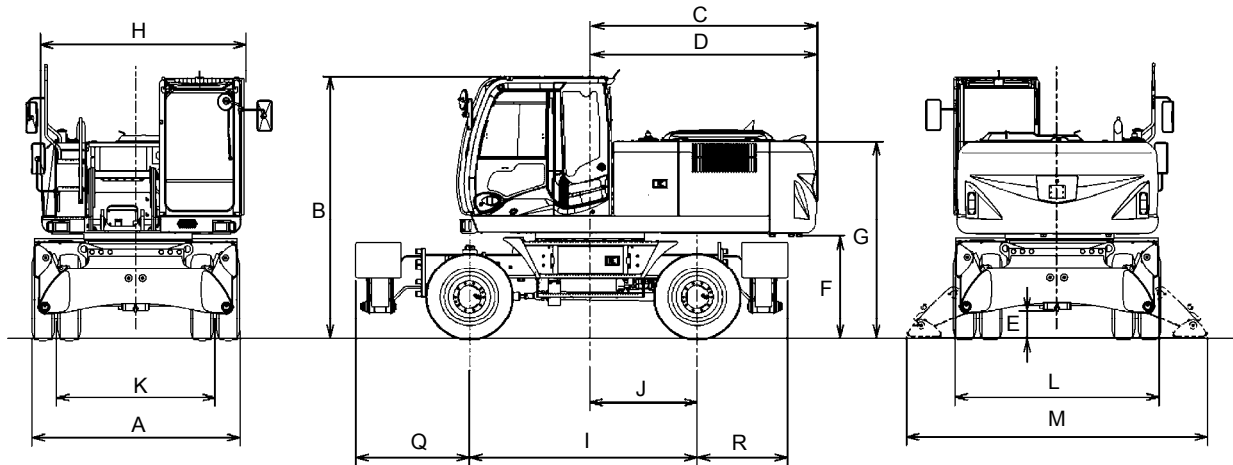

MCGB-12-026

Type of Front-End Attachment		Monoblock Boom	2-Piece Boom
Type of Arm		2.91m (9 ft 7 in)	2.41m (7 ft 11 in)
Bucket Capacity (Heaped)		PCSA 0.80 m ³ (1.05 yd ³), CECE 0.70 m ³	
Operating Weight		kg (lb)	20900 (46100)
Basic Machine Weight		kg (lb)	17100 (37700)
Engine		ISUZU AI-4HK1X	
Engine Power		SAE J1349 net	122 kW/2000 min ⁻¹ (166 PS/2000 rpm)
		ISO 9249 net	
		EEC 80/1269 net	
A: Overall Width (Excluding Rearview Mirrors)	mm (ft·in)	2530 (8' 4")	
B: Cab Height	mm (ft·in)	3170 (10' 5")	
C: Rear End Swing Radius	mm (ft·in)	2750 (9' 0")	
D: Rear End Length	mm (ft·in)	2750 (9' 0")	
E: Minimum Ground Clearance	mm (ft·in)	325 (1' 1")	
F: Counterweight Clearance	mm (ft·in)	1230 (4' 0")	
G: Engine Cover Height	mm (ft·in)	2520 (8' 3")	
H: Overall Width of Upperstructure	mm (ft·in)	2470 (8' 1")	
I: Wheelbase	mm (ft·in)	2750 (9' 0")	
J: Swing-Center to Rear Axle	mm (ft·in)	1300 (4' 3")	
K: Front Wheel Tread	mm (ft·in)	1915 (6' 3")	
L: Rear Wheel Tread	mm (ft·in)	1915 (6' 3")	
M: Outrigger Spread	mm (ft·in)	3440 (11' 3")	
N: Max. Raising Height	mm (ft·in)	-	
O: Max. Digging Depth	mm (ft·in)	-	
P: Blade Height	mm (ft·in)	-	
Q: Front Axle to Front of Chassis	mm (ft·in)	1375 (4' 6")	
R: Rear Axle to Rear of Chassis	mm (ft·in)	1090 (3' 7")	
Tire Size		10.00-20 16PR	
Swing Speed		min ⁻¹ (rpm)	12.2
Travel Speed (fast / Slow / Creeper) *		km/h (mph)	27.5/7.4/2.9 (17.1/4.6/1.8)
Gradeability		Degree (%)	35 (70)

NOTE: "*" The specification not matching the local regulation is excluded.

GENERAL / Specifications

ZX220W-3 (Standard GAUGE, REAR BLADE)

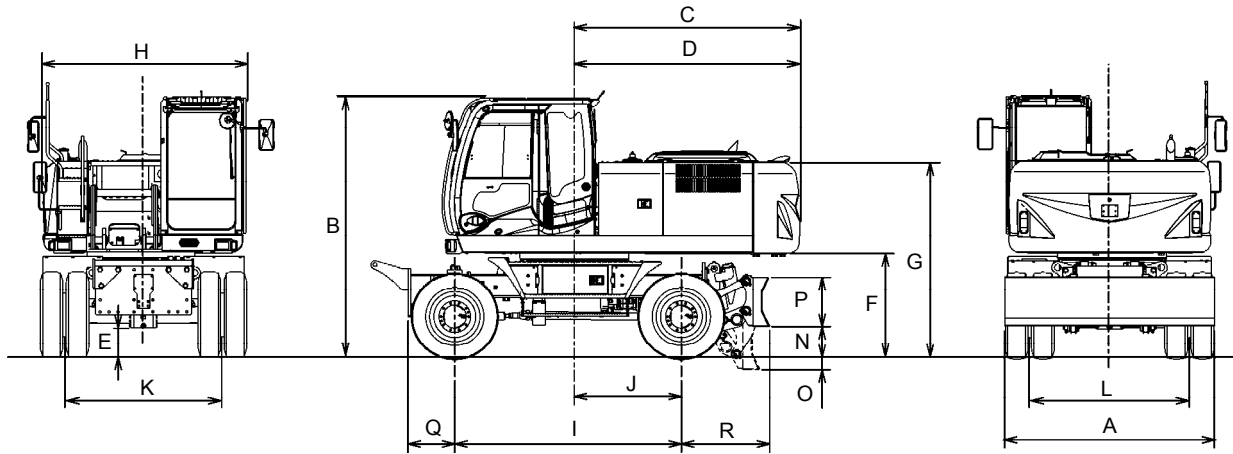

MCGB-12-022

Type of Front-End Attachment		Monoblock Boom	2-Piece Boom
Type of Arm		2.91m (9 ft 7 in)	2.41m (7 ft 11 in)
Bucket Capacity (Heaped)		PCSA 0.80 m ³ (1.05 yd ³), CECE 0.70 m ³	
Operating Weight	kg (lb)	21100 (46500)	21900 (48300)
Basic Machine Weight	kg (lb)	17100 (37700)	17100 (37700)
Engine		ISUZU AI-4HK1X	
Engine Power	SAE J1349 net	122 kW/2000 min ⁻¹ (166 PS/2000 rpm)	
	ISO 9249 net		
	EEC 80/1269 net		
A: Overall Width (Excluding Rearview Mirrors)	mm (ft-in)	2760 (9' 1")	
B: Cab Height	mm (ft-in)	3190 (10' 6")	
C: Rear End Swing Radius	mm (ft-in)	2750 (9' 0")	
D: Rear End Length	mm (ft-in)	2750 (9' 0")	
E: Minimum Ground Clearance	mm (ft-in)	320 (1' 1")	
F: Counterweight Clearance	mm (ft-in)	1250 (4' 1")	
G: Engine Cover Height	mm (ft-in)	2540 (8' 4")	
H: Overall Width of Upperstructure	mm (ft-in)	2470 (8' 1")	
I: Wheelbase	mm (ft-in)	2750 (9' 0")	
J: Swing-Center to Rear Axle	mm (ft-in)	1300 (4' 3")	
K: Front Wheel Tread	mm (ft-in)	2140 (7' 0")	
L: Rear Wheel Tread	mm (ft-in)	2140 (7' 0")	
M: Outrigger Spread	mm (ft-in)	-	
N: Max. Raising Height	mm (ft-in)	395 (1' 4")	
O: Max. Digging Depth	mm (ft-in)	195 (8")	
P: Blade Height	mm (ft-in)	600 (2' 0")	
Q: Front Axle to Front of Chassis	mm (ft-in)	605 (2' 0")	
R: Rear Axle to Rear of Chassis	mm (ft-in)	1075 (3' 6")	
Tire Size		11.00-20 16PR	
Swing Speed	min ⁻¹ (rpm)	12.2	
Travel Speed (Fast / Slow / Creeper) *	km/h (mph)	27.5/7.4/2.9 (17.1/4.6/1.8)	
Gradeability	Degree (%)	35 (70)	

NOTE: "*" The specification not matching the local regulation is excluded.

GENERAL / Specifications

ZX220W-3 (Standard GAUGE, REAR OUTRIGGER)

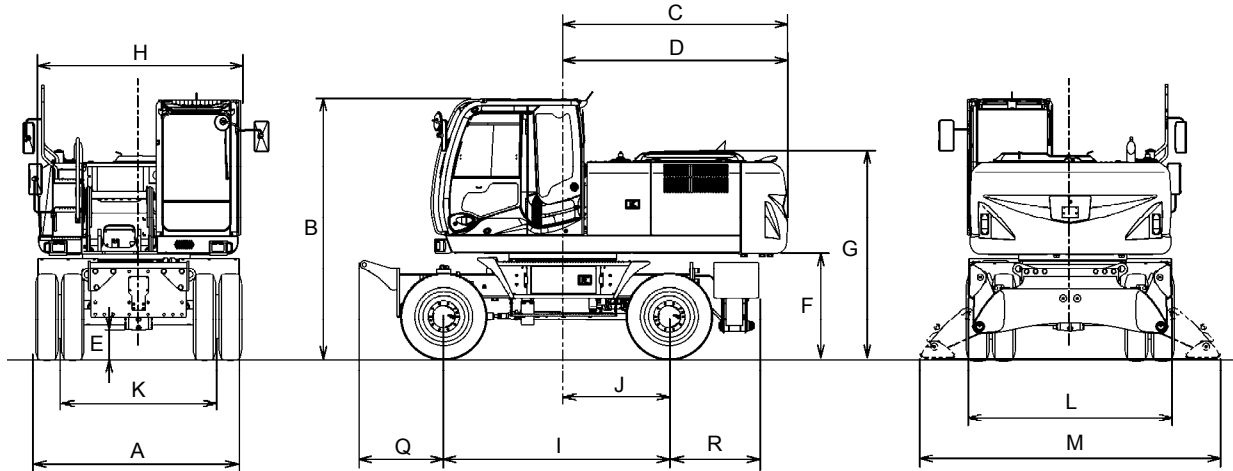

MCGB-12-023

Type of Front-End Attachment		Monoblock Boom	2-Piece Boom
Type of Arm		2.91m (9 ft 7 in)	2.41m (7 ft 11 in)
Bucket Capacity (Heaped)		PCSA 0.80 m ³ (1.05 yd ³), CECE 0.70 m ³	
Operating Weight		kg (lb)	21100 (46500)
Basic Machine Weight		kg (lb)	17200 (37900)
Engine		ISUZU AI-4HK1X	
Engine Power		SAE J1349 net	122 kW/2000 min ⁻¹ (166 PS/2000 rpm)
		ISO 9249 net	
		EEC 80/1269 net	
A: Overall Width (Excluding Rearview Mirrors)	mm (ft-in)	2760 (9' 1")	
B: Cab Height	mm (ft-in)	3190 (10' 6")	
C: Rear End Swing Radius	mm (ft-in)	2750 (9' 0")	
D: Rear End Length	mm (ft-in)	2950 (9' 0")	
E: Minimum Ground Clearance	mm (ft-in)	345 (1' 2")	
F: Counterweight Clearance	mm (ft-in)	1250 (4' 1")	
G: Engine Cover Height	mm (ft-in)	2540 (8' 4")	
H: Overall Width of Upperstructure	mm (ft-in)	2470 (8' 1")	
I: Wheelbase	mm (ft-in)	2750 (9' 0")	
J: Swing-Center to Rear Axle	mm (ft-in)	1300 (4' 3")	
K: Front Wheel Tread	mm (ft-in)	2140 (7' 0")	
L: Rear Wheel Tread	mm (ft-in)	2140 (7' 0")	
M: Outrigger Spread	mm (ft-in)	3700 (12' 2")	
N: Max. Raising Height	mm (ft-in)	-	
O: Max. Digging Depth	mm (ft-in)	-	
P: Blade Height	mm (ft-in)	-	
Q: Front Axle to Front of Chassis	mm (ft-in)	605 (2' 0")	
R: Rear Axle to Rear of Chassis	mm (ft-in)	1090 (3' 7")	
Tire Size		11.00-20 16PR	
Swing Speed	min ⁻¹ (rpm)	12.2	
Travel Speed (Fast / Slow / Creeper) *	km/h (mph)	27.5/7.4/2.9 (17.1/4.6/1.8)	
Gradeability	Degree (%)	35 (70)	

NOTE: “*” The specification not matching the local regulation is excluded.

GENERAL / Specifications

ZX220W-3 (Standard GAUGE, FRONT BLADE REAR OUTRIGGER)

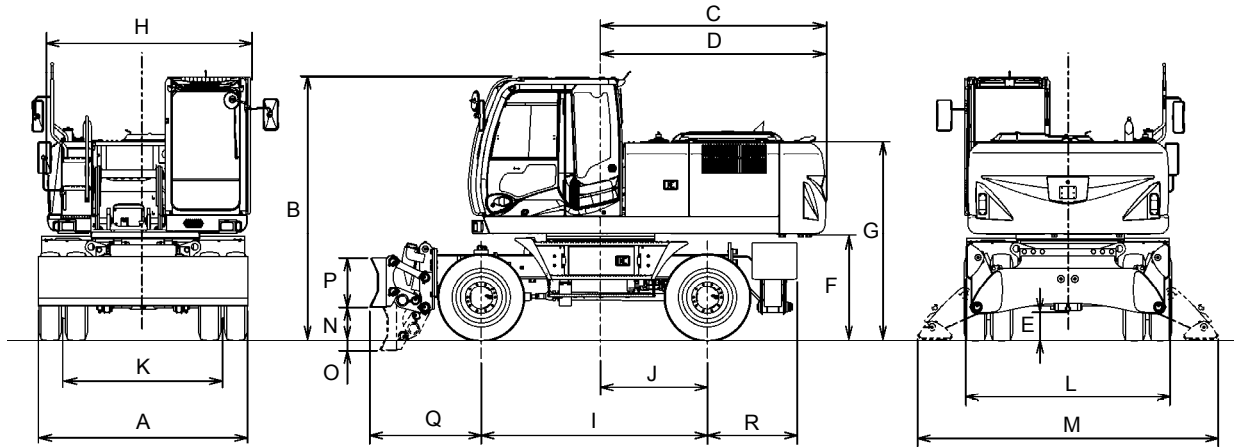

MCGB-12-024

Type of Front-End Attachment		Monoblock Boom	2-Piece Boom
Type of Arm		2.91m (9 ft 7 in)	2.41m (7 ft 11 in)
Bucket Capacity (Heaped)		PCSA 0.80 m ³ (1.05 yd ³), CECE 0.70 m ³	
Operating Weight	kg (lb)	22100 (48700)	22900 (50500)
Basic Machine Weight	kg (lb)	18100 (39900)	18100 (39900)
Engine		ISUZU AI-4HK1X	
Engine Power	SAE J1349 net	122 kW/2000 min ⁻¹ (166 PS/2000 rpm)	
	ISO 9249 net		
	EEC 80/1269 net		
A: Overall Width (Excluding Rearview Mirrors)	mm (ft-in)	2760 (9' 1")	
B: Cab Height	mm (ft-in)	3190 (10' 6")	
C: Rear End Swing Radius	mm (ft-in)	2750 (9' 0")	
D: Rear End Length	mm (ft-in)	2750 (9' 0")	
E: Minimum Ground Clearance	mm (ft-in)	320 (1' 1")	
F: Counterweight Clearance	mm (ft-in)	1250 (4' 1")	
G: Engine Cover Height	mm (ft-in)	2540 (8' 4")	
H: Overall Width of Upperstructure	mm (ft-in)	2470 (8' 1")	
I: Wheelbase	mm (ft-in)	2750 (9' 0")	
J: Swing-Center to Rear Axle	mm (ft-in)	1300 (4' 3")	
K: Front Wheel Tread	mm (ft-in)	2140 (7' 0")	
L: Rear Wheel Tread	mm (ft-in)	2140 (7' 0")	
M: Outrigger Spread	mm (ft-in)	3700 (12' 2")	
N: Max. Raising Height	mm (ft-in)	395 (1' 4")	
O: Max. Digging Depth	mm (ft-in)	195 (8")	
P: Blade Height	mm (ft-in)	600 (2' 0")	
Q: Front Axle to Front of Chassis	mm (ft-in)	1355 (4' 5")	
R: Rear Axle to Rear of Chassis	mm (ft-in)	1090 (3' 7")	
Tire Size		11.00-20 16PR	
Swing Speed	min ⁻¹ (rpm)	12.2	
Travel Speed (fast / Slow / Creeper) *	km/h (mph)	27.5/7.4/2.9 (17.1/4.6/1.8)	
Gradeability	Degree (%)	35 (70)	

NOTE: "*" The specification not matching the local regulation is excluded.

GENERAL / Specifications

ZX220W-3 (Standard GAUGE, FRONT OUTRIGGER REAR BLADE)

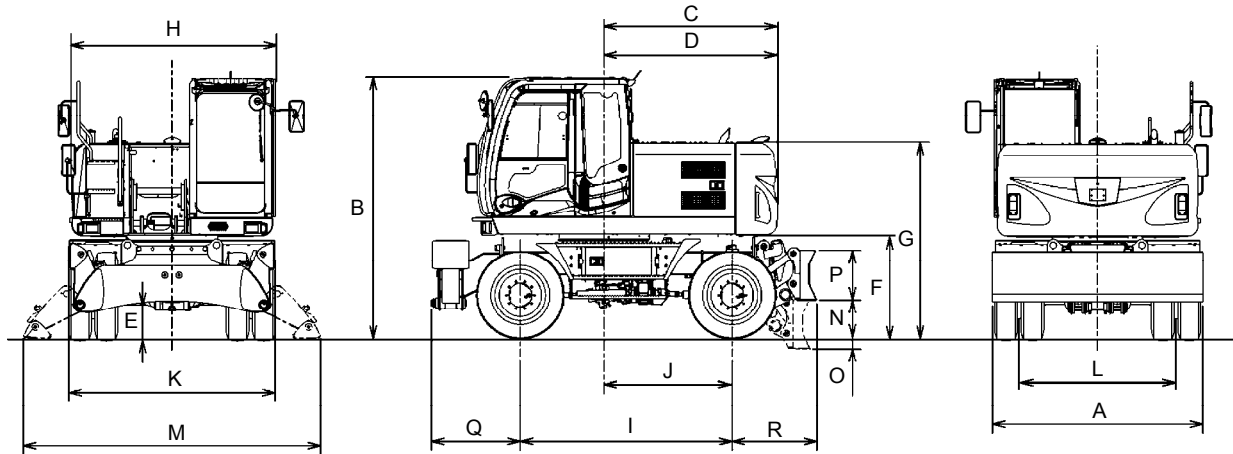

MCGB-12-025

Type of Front-End Attachment		Monoblock Boom	2-Piece Boom
Type of Arm		2.91m (9 ft 7 in)	2.41m (7 ft 11 in)
Bucket Capacity (Heaped)		PCSA 0.80 m ³ (1.05 yd ³), CECE 0.70 m ³	
Operating Weight		kg (lb)	22100 (48700)
Basic Machine Weight		kg (lb)	18100 (39900)
Engine		ISUZU AI-4HK1X	
Engine Power		SAE J1349 net	122 kW/2000 min ⁻¹ (166 PS/2000 rpm)
		ISO 9249 net	
		EEC 80/1269 net	
A: Overall Width (Excluding Rearview Mirrors)	mm (ft-in)	2760 (9' 1")	
B: Cab Height	mm (ft-in)	3190 (10' 6")	
C: Rear End Swing Radius	mm (ft-in)	2750 (9' 0")	
D: Rear End Length	mm (ft-in)	2750 (9' 0")	
E: Minimum Ground Clearance	mm (ft-in)	320 (1' 1")	
F: Counterweight Clearance	mm (ft-in)	1250 (4' 1")	
G: Engine Cover Height	mm (ft-in)	2540 (8' 4")	
H: Overall Width of Upperstructure	mm (ft-in)	2470 (8' 1")	
I: Wheelbase	mm (ft-in)	2750 (9' 0")	
J: Swing-Center to Rear Axle	mm (ft-in)	1300 (4' 3")	
K: Front Wheel Tread	mm (ft-in)	2140 (7' 0")	
L: Rear Wheel Tread	mm (ft-in)	2140 (7' 0")	
M: Outrigger Spread	mm (ft-in)	3700 (12' 2")	
N: Max. Raising Height	mm (ft-in)	395 (1' 4")	
O: Max. Digging Depth	mm (ft-in)	195 (8")	
P: Blade Height	mm (ft-in)	600 (2' 0")	
Q: Front Axle to Front of Chassis	mm (ft-in)	1375 (4' 6")	
R: Rear Axle to Rear of Chassis	mm (ft-in)	1075 (3' 6")	
Tire Size		11.00-20 16PR	
Swing Speed		min ⁻¹ (rpm)	12.2
Travel Speed (Fast / Slow / Creeper) *		km/h (mph)	27.5/7.4/2.9 (17.1/4.6/1.8)
Gradeability		Degree (%)	35 (70)

NOTE: "*" The specification not matching the local regulation is excluded.

GENERAL / Specifications

ZX220W-3 (Standard GAUGE, FRONT OUTRIGGER REAR OUTRIGGER)

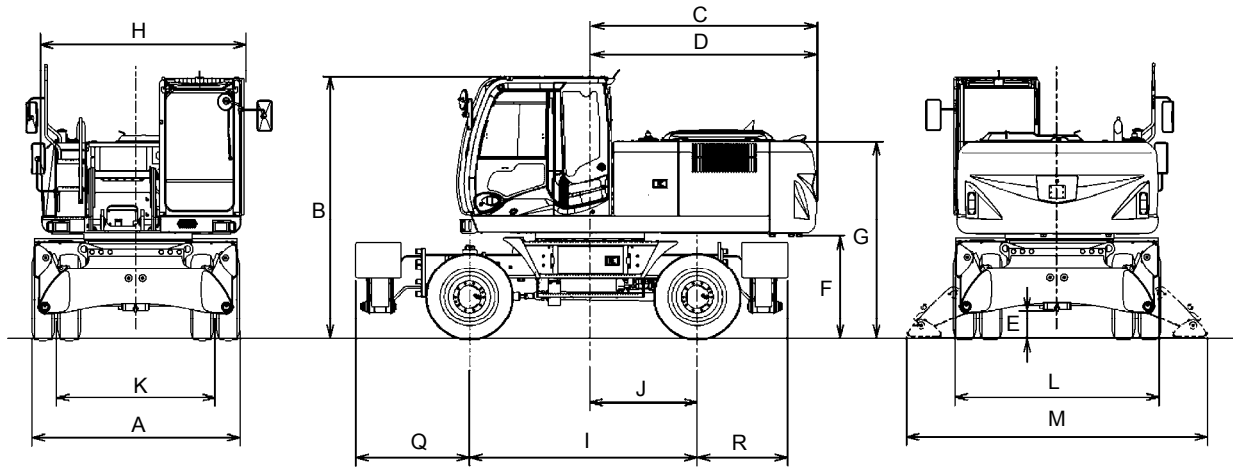

MCGB-12-026

Type of Front-End Attachment		Monoblock Boom	2-Piece Boom
Type of Arm		2.91m (9 ft 7 in)	2.41m (7 ft 11 in)
Bucket Capacity (Heaped)		PCSA 0.80 m ³ (1.05 yd ³), CECE 0.70 m ³	
Operating Weight		kg (lb)	22100 (48700) 23000 (50700)
Basic Machine Weight		kg (lb)	18200 (40100) 18200 (40100)
Engine		ISUZU AI-4HK1X	
Engine Power		SAE J1349 net	122 kW/2000 min ⁻¹ (166 PS/2000 rpm)
		ISO 9249 net	
		EEC 80/1269 net	
A: Overall Width (Excluding Rearview Mirrors)	mm (ft·in)	2760 (9' 1")	
B: Cab Height	mm (ft·in)	3190 (10' 6")	
C: Rear End Swing Radius	mm (ft·in)	2750 (9' 0")	
D: Rear End Length	mm (ft·in)	2750 (9' 0")	
E: Minimum Ground Clearance	mm (ft·in)	345 (1' 2")	
F: Counterweight Clearance	mm (ft·in)	1250 (4' 1")	
G: Engine Cover Height	mm (ft·in)	2540 (8' 4")	
H: Overall Width of Upperstructure	mm (ft·in)	2470 (8' 1")	
I: Wheelbase	mm (ft·in)	2750 (9' 0")	
J: Swing-Center to Rear Axle	mm (ft·in)	1300 (4' 3")	
K: Front Wheel Tread	mm (ft·in)	2140 (7' 0")	
L: Rear Wheel Tread	mm (ft·in)	2140 (7' 0")	
M: Outrigger Spread	mm (ft·in)	3700 (12' 2")	
N: Max. Raising Height	mm (ft·in)	-	
O: Max. Digging Depth	mm (ft·in)	-	
P: Blade Height	mm (ft·in)	-	
Q: Front Axle to Front of Chassis	mm (ft·in)	1375 (4' 6")	
R: Rear Axle to Rear of Chassis	mm (ft·in)	1090 (3' 7")	
Tire Size		11.00-20 16PR	
Swing Speed		min ⁻¹ (rpm)	12.2
Travel Speed (fast / Slow / Creeper) *		km/h (mph)	27.5/7.4/2.9 (17.1/4.6/1.8)
Gradeability		Degree (%)	35 (70)

NOTE: "*" The specification not matching the local regulation is excluded.

GENERAL / Specifications

(Blank)

GENERAL / Specifications

WORKING RANGES

**ZX210W-3, 220W-3
MONOBLOCK BOOM**

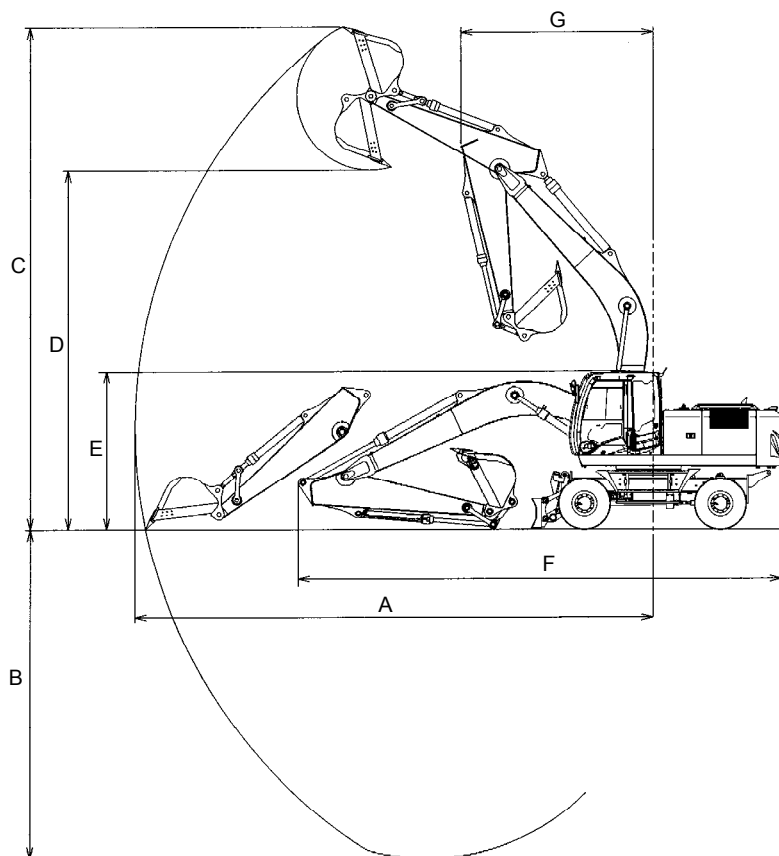

MCGB-12-027

Type of Front-End Attachment		Monoblock Boom		
		2.03 m (6 ft 8 in) Arm	2.42 m (7 ft 11 in) Arm	2.91 m (9 ft 7 in) Arm
Category		Backhoe	Backhoe	Backhoe
Item				
A: Maximum Digging Reach	mm (ft·in)	9470 (31' 1")	9670 (31' 9")	10170 (33' 4")
B: Maximum Digging Depth	mm (ft·in)	5410 (17' 9")	5800 (19' 0")	6290 (20' 8")
C: Maximum Cutting Height	mm (ft·in)	10020 (32' 11")	9840 (32' 3")	10190 (33' 5")
D: Maximum Dumping Height	mm (ft·in)	7110 (23' 4")	7000 (23' 0")	7350 (24' 1")
E: Transport Height	mm (ft·in)	3220 (10' 7")	3230 (10' 7")	ZX210W-3: 2990 (9' 10") ZX220W-3: 3190 (10' 6")
F: Overall Transport Length				
Rear BL.	mm (ft·in)	* 9145 (30' 0")	* 9155 (30' 0")	* 9005 (29' 7")
Rear O/R.	mm (ft·in)	* 9145 (30' 0")	* 9155 (30' 0")	* 9005 (29' 7")
Front BL. Rear O/R.	mm (ft·in)	* 9895 (32' 6")	* 9905 (32' 6")	* 9755 (32' 0")
Front O/R. Rear BL.	mm (ft·in)	* 9915 (32' 6")	* 9925 (32' 7")	* 9775 (32' 1")
Front O/R. Rear O/R.	mm (ft·in)	* 9915 (32' 6")	* 9925 (32' 7")	* 9775 (32' 1")
G: Minimum Swing Radius	mm (ft·in)	3650 (12' 0")	3520 (11' 7")	3430 (11' 3")

NOTE: "*" Transport the machine with the rear side facing forward.
BL: Blade, O/R: Outrigger