

Parts Manual for Series C14B Hydraulic Backhoes

NOTE:

The parts pages are intended for use in ordering parts, and therefore do not always depict the correct way to assemble components.

9308135



CONSTRUCTION EQUIPMENT DIVISION
WAUKESHA, WISCONSIN 53186

ABOUT THIS MANUAL

This manual incorporates a new simplified page numbering system. The book is divided into major categories or sections, each of which is separated by an index tab sheet. Pages are numbered consecutively within each section. For example, let's say the section entitled "Pumps and Motors" contains the following pages:

| | |
|--------|-----------------------|
| Page 1 | Dipstick or Boom Pump |
| Page 2 | Swing and Boost Pump |
| Page 3 | Swing Motor |
| Page 4 | Propel Motor |

Should we add a pump to the machine at a future date, it would simply become "page 5."

If we change one of the existing pages, the new page would have the same number. For example, if we change the vendor on the swing motor, a new page would be prepared. This new page would also be "page 3". Thus, each Master Parts Manual would then contain two page 3's. The effective date and serial number block will be your key to determine which page to use for a particular machine.

Each page includes the name of the major category to which it belongs. This is found below the title of the page itself, and will enable you to file newly released pages in their proper location in your Master Parts Manual.

As in the past, customer manuals will be individually assembled, and contain only those pages which apply to his particular machine.

INSTRUCTIONS FOR ORDERING REPLACEMENT PARTS

To assure prompt and accurate service, include the following data with each parts order:

1. Purchase Order Number
2. Model and Serial Number of Machine
3. Part Numbers
4. Part Descriptions
5. Quantity of each part desired
6. Method of transportation

Confirm all telephone and telegraph orders in writing. Be sure these orders are marked "Confirmation", to avoid duplication of orders.

INSPECTION OF SHIPMENTS

Carefully inspect all shipments upon arrival. In the event of loss or damage, do not accept the shipment until the transportation company either makes a notation on the freight bill, or gives you an inspection report covering said damage or loss. In the event of concealed damage or loss, notify the carrier at once (within 20 days) requesting that an inspection be made and damage or loss be acknowledged.

USE ONLY GENUINE HEIN-WERNER PARTS FOR MAXIMUM PERFORMANCE

WHERE TO ORDER PARTS

Contact the Hein-Werner dealer in your area when placing parts orders. Hein-Werner Dealers are conveniently located throughout the United States and Canada. These Dealers maintain a stock of genuine Hein-Werner replacement parts so that orders are filled as quickly as possible. To aid the dealer in processing your order promptly and correctly, you should supply the following information:

1. Model and Serial Number of your Machine.
2. Part Numbers of items desired
3. Part Descriptions
4. Quantity of each part desired
5. Method of transportation

INSPECTION OF SHIPMENTS

Carefully inspect all shipments upon arrival. In the event of loss or damage, do not accept the shipment until the transportation company either makes a notation on the freight bill, or gives you an inspection report covering said damage or loss. In the event of concealed damage or loss, notify the carrier at once (within 20 days) requesting that an inspection be made and damage or loss be acknowledged.

USE ONLY GENUINE HEIN-WERNER PARTS FOR MAXIMUM PERFORMANCE



OPERATION

The information in this manual is designed to furnish the owner and operator of the Hein-Werner C-14B Backhoe with the basic information needed to understand the operation of the machine.

For safe and efficient operation, first become familiar with the location and purpose of all controls and instruments. Study the following pages carefully, regardless of your previous experience.

SAFETY FIRST

THE COMPLETE OBSERVANCE of this one simple motto would prevent many thousand serious injuries each year.

ENGINE CONTROLS AND INSTRUMENTS

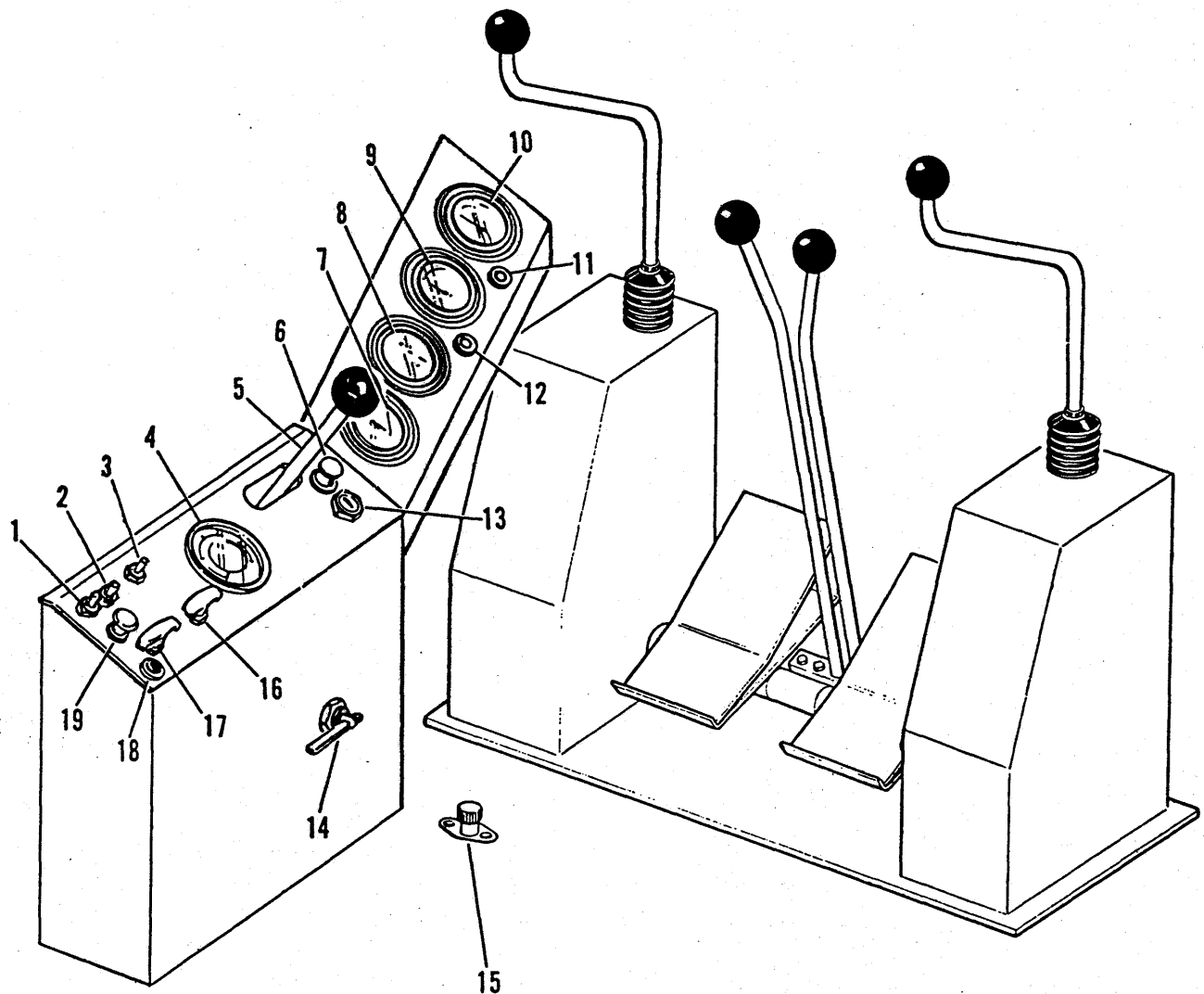

- | | | | |
|-----|-----------------------------|-----|---|
| 1. | Dome Light Switch | 11. | Reservoir Oil Temperature Warning Light |
| 2. | Flood Light Switch | 12. | Hydraulic Filter Pressure Warning Light |
| 3. | Flood Light Switch | 13. | Ignition Switch |
| 4. | Tachometer (with hourmeter) | 14. | Summation Mode Selector |
| 5. | Engine Speed Control | 15. | Horn Button |
| 6. | Cigarette Lighter | 16. | Engine Shutdown Control |
| 7. | Fuel Gauge | 17. | Emergency Engine Shutdown Control |
| 8. | Ammeter | 18. | Starter Button |
| 9. | Water Temperature Gauge | 19. | Heater Switch |
| 10. | Engine Oil Pressure Gauge | | |

ENGINE AND INSTRUMENTS

When operating the machine, periodic attention should be given to the instrument panel gauges and warning lights. This will prevent any minor malfunction from becoming a major breakdown.

WARNING LIGHTS

11. Reservoir Oil Temperature Warning Light: This warning light will glow if the hydraulic oil overheats. If this happens, immediately stop the engine and investigate the cause.
12. Filter Pressure Warning Light: This warning light will glow if the hydraulic filter becomes clogged or inoperative. It is not to be used to determine filter replacement. For filter replacement, refer to the Lubrication section.

GAUGES

4. Tachometer: The engine governed speed has been preset at 2500 R.P.M. (clutch engaged) at full throttle. The engine should never exceed 2650 R.P.M.
8. Ammeter Gauge: The ammeter indicates either battery charge or discharge depending on the condition of the battery.
9. Water Temperature Gauge: Under normal engine operating conditions the water temperature should be 160 to 185 F.
10. Engine Oil Pressure Gauge: The oil pressure gauge should indicate 40 to 60 P.S.I. at full throttle. Should the pressure fall below this range (other than at idle) immediately shut off the engine and investigate the cause.

JOY STICK CONTROLS

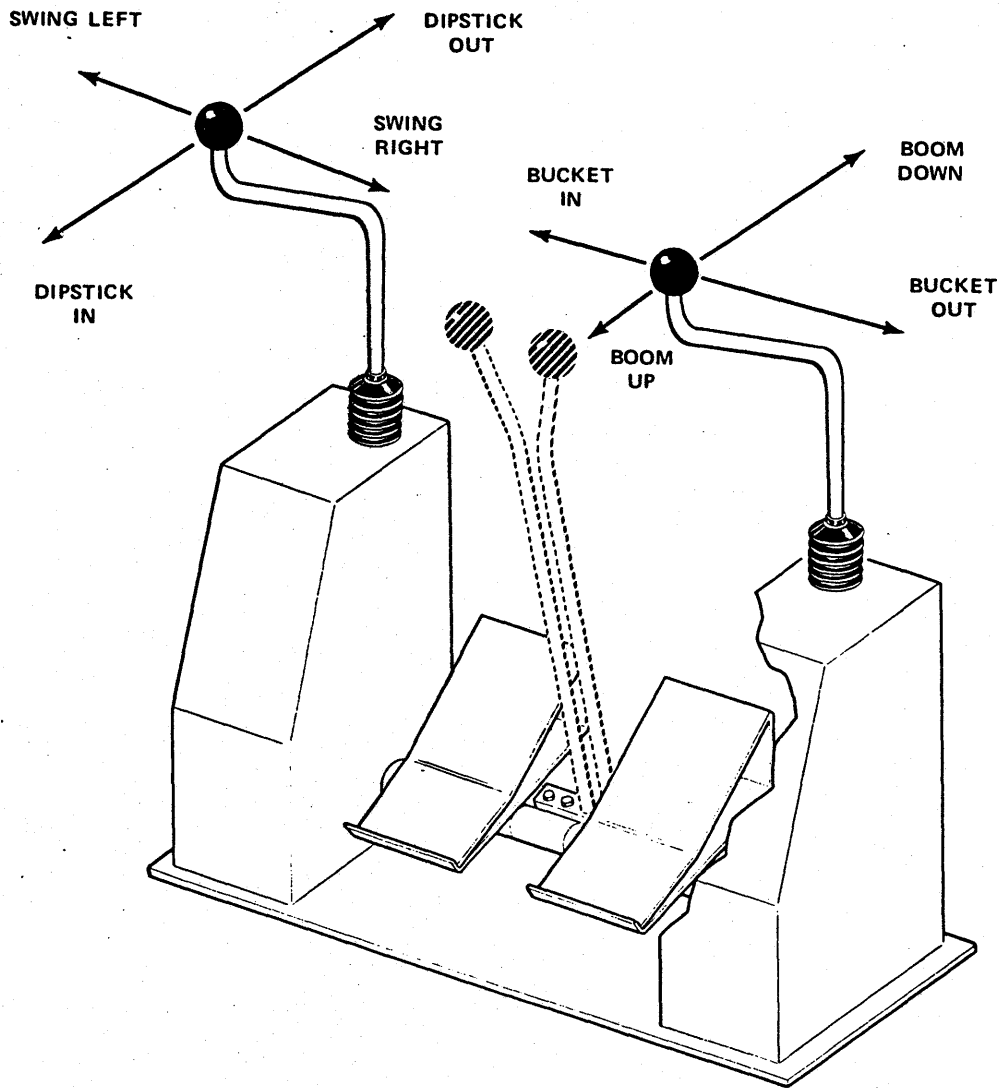

DIGGING CONTROL LEVERS

Operators not familiar with hydraulic machines may tend to over-control and thereby cause rough operation of the machine. Therefore, it is recommended that the machine be operated slowly until the operator becomes thoroughly oriented with the controls.

1. Boom Control Lever

- A. To raise the boom, pull back on the right hand control lever.
- B. When the control lever is returned to the neutral position (center), the boom will remain positioned.
- C. To lower the boom, push the right hand control lever forward.

DIGGING CONTROL LEVERS (Cont.)

2. Swing Control Lever

- A. To swing the platform in a clockwise direction, disengage the swing brake and push left hand control lever to the right.
- B. To swing the platform in a counter-clockwise direction, push the left hand control lever to the left.
- C. To stop swing rotation in either direction, feather the control lever in the opposite direction until rotation stops.

CAUTION: WHENEVER THE MACHINE IS NOT BEING OPERATED, ALWAYS ENGAGE SWING BRAKE AND LOWER BUCKET TO THE GROUND.

3. Dipstick Control

- A. To tuck the dipstick, pull back the left hand control lever.
- B. When the left hand control lever is returned to the neutral position (center), the dipstick will remain positioned.
- C. To extend the dipstick, push the left hand control lever forward.

4. Bucket Control

- A. To curl bucket, push the right hand control lever to the left.
- B. When the control lever is returned to the neutral position (center), the bucket will remain positioned.
- C. To dump bucket, push the right hand control lever to the right.

**A Careful Operator
IS THE BEST INSURANCE
AGAINST AN ACCIDENT**