

# VW Golf & Jetta Service and Repair Manual

---

I M Coomber and Christopher Rogers

---

**Models covered**

(1081 - 344 - 1AA11)

VW Golf & Jetta Mk 2 models with petrol engines, including fuel injection, catalytic converter, Formel E, 16-valve and special/limited edition models 1043 cc, 1272 cc, 1595 cc & 1781 cc

*Covers mechanical features of Van. Does not cover Convertible, Rallye, Caddy, diesel engine, 4-wheel drive, Mk 1 models or new Golf range introduced in February 1992*

© Haynes Publishing 1997

A book in the **Haynes Service and Repair Manual Series**

All rights reserved. No part of this book may be reproduced or transmitted in any form or by any means, electronic or mechanical, including photocopying, recording or by any information storage or retrieval system, without permission in writing from the copyright holder.

ISBN 1 85960 282 7

**British Library Cataloguing in Publication Data**  
A catalogue record for this book is available from the British Library

ABCDE  
FGHIJ  
KLMNO  
PQRST  
1 2 3

Printed by J H Haynes & Co. Ltd, Sparkford, Nr Yeovil, Somerset  
**BA22 7JJ, England**

**Haynes Publishing**  
Sparkford Nr Yeovil  
Somerset BA22 7JJ England

**Haynes North America, Inc**  
861 Lawrence Drive  
Newbury Park  
California 91320 USA

**Editions Haynes S.A.**  
147/149, rue Saint Honoré, 75001 PARIS, France

**Haynes Publishing Nordiska AB**  
Fyrisborgsgatan 5, 754 50 Uppsala, Sverige

# Contents

---

## LIVING WITH YOUR VOLKSWAGEN GOLF OR JETTA

Introduction	Page	0•4
Safety First!	Page	0•5

---

### Roadside Repairs

Introduction	Page	0•6
If your car won't start	Page	0•6
Jump starting	Page	0•7
Wheel changing	Page	0•8
Identifying leaks	Page	0•9
Towing	Page	0•9

---

### Weekly Checks

Introduction	Page	0•10
Underbonnet check points	Page	0•10
Engine oil level	Page	0•11
Coolant level	Page	0•11
Brake fluid level	Page	0•12
Power steering fluid level	Page	0•12
Screen/headlamp washer fluid level	Page	0•13
Wiper blades	Page	0•13
Tyre condition and pressure	Page	0•14
Battery	Page	0•15
Electrical systems	Page	0•15

---

Lubricants and fluids	Page	0•16
-----------------------	------	------

---

Capacities and tyre pressures	Page	0•17
-------------------------------	------	------

---

## MAINTENANCE

### Routine Maintenance and Servicing

Servicing specifications	Page	1•2
Maintenance schedule:		
Vehicles manufactured before August 1985	Page	1•5
Vehicles manufactured after August 1985	Page	1•6
Maintenance - component location	Page	1•7
Maintenance procedures	Page	1•10

---

# Contents

---

## REPAIRS & OVERHAUL

### Engine and Associated Systems

Engine repair procedures - 1.05 and 1.3 litre - pre August 1985	Page	<b>2A•1</b>
Engine repair procedures - 1.05 and 1.3 litre - post August 1985	Page	<b>2B•1</b>
Engine repair procedures - 1.6 and 1.8 litre 8 valve	Page	<b>2C•1</b>
Engine repair procedures - 1.8 litre 16 valve	Page	<b>2D•1</b>
Cooling, heating and air conditioning systems	Page	<b>3•1</b>
Fuel and exhaust systems - carburettor models	Page	<b>4A•1</b>
Fuel and exhaust systems - K-Jetronic fuel injection - 8 valve engines	Page	<b>4B•1</b>
Fuel and exhaust systems - K-Jetronic fuel injection - 16 valve engines	Page	<b>4C•1</b>
Fuel and exhaust systems - Mono Jetronic fuel injection	Page	<b>4D•1</b>
Fuel and exhaust systems - Digijet fuel injection	Page	<b>4E•1</b>
Fuel and exhaust systems - Digifant fuel injection	Page	<b>4F•1</b>
Ignition system - contact breaker type	Page	<b>5A•1</b>
Ignition system - transistorised type	Page	<b>5B•1</b>
Ignition system - fully electronic type	Page	<b>5C•1</b>
Starting and charging systems	Page	<b>5D•1</b>

### Transmission

Clutch	Page	<b>6•1</b>
Manual gearbox	Page	<b>7A•1</b>
Automatic transmission	Page	<b>7B•1</b>
Driveshafts	Page	<b>8•1</b>

### Brakes and Suspension

Braking system	Page	<b>9•1</b>
Suspension and steering	Page	<b>10•1</b>

### Body Equipment

Bodywork and fittings	Page	<b>11•1</b>
Body electrical systems	Page	<b>12•1</b>

### Wiring Diagrams

Page **12•17**

## REFERENCE

Dimensions and Weights	Page	<b>REF•1</b>
Conversion Factors	Page	<b>REF•2</b>
Buying Spare Parts and Vehicle Identification	Page	<b>REF•3</b>
General Repair Procedures	Page	<b>REF•4</b>
Jacking and Vehicle Support	Page	<b>REF•5</b>
Tools and Working Facilities	Page	<b>REF•6</b>
MOT test checks	Page	<b>REF•8</b>
Fault Finding	Page	<b>REF•12</b>
Glossary of Technical Terms	Page	<b>REF•20</b>

### Index

Page **REF•25**

---

## 0•4 Introduction

The Mk. II Volkswagen Golf and Jetta range of models was introduced in March 1984, revised body and trim features being the main visual difference to the earlier range of models.

The engine/transmission is mounted transversely at the front of the vehicle, drive being to the front wheels. Detailed improvements have been made throughout the years of manufacture to improve power output and economy. These include the introduction of hydraulic

bucket tappets, the Digifant, Digijet and Mono-Jetronic fuel injection systems, the 16-valve engine fitted to the GTi variant, the fully electronic ignition system (FEI), the 085 5-speed gearbox and several other minor modifications and revisions.

As with earlier models the new range is proving popular, giving economy, reliability, comfort and, if previous models can be used as a yardstick, long life.



VW Golf



VW Jetta

### The VW Golf & Jetta Team

Haynes manuals are produced by dedicated and enthusiastic people working in close co-operation. The team responsible for the creation of this book included:

<b>Authors</b>	<b>Ian Coomber Christopher Rogers</b>
<b>Sub-editors</b>	<b>Carole Turk Sophie Yar</b>
<b>Editor &amp; Page Make-up</b>	<b>Steve Churchill</b>
<b>Workshop manager</b>	<b>Paul Buckland</b>
<b>Photo Scans</b>	<b>John Martin Paul Tanswell Steve Tanswell</b>
<b>Cover illustration &amp; Line Art</b>	<b>Roger Healing</b>

We hope the book will help you to get the maximum enjoyment from your car. By carrying out routine maintenance as described you will ensure your car's reliability and preserve its resale value.

### Your Volkswagen Golf and Jetta Manual

The aim of this Manual is to help you get the best value from your vehicle. It can do so in several ways. It can help you decide what work must be done (even should you choose to get it done by a garage), provide information on routine maintenance and servicing, and give a logical course of action and diagnosis when random faults occur. However, it is hoped that you will use the Manual by tackling the work yourself. On simpler jobs it may even be quicker than booking the car into a garage and going there twice, to leave and collect it. Perhaps most important, a lot of money can be saved by avoiding the costs a garage must charge to cover its labour and overheads.

The Manual has drawings and descriptions to show the function of the various components so that their layout can be understood. Then the tasks are described and photographed in a clear step-by-step sequence.

### Acknowledgements

Thanks are due to Champion Spark Plug who supplied the illustrations showing spark plug conditions, to Duckhams Oils, who provided lubrication data and also to Sykes-Pickavant Limited, who supplied some of the workshop tools, and to all those people at Sparkford who helped in the production of this Manual.

We take great pride in the accuracy of information given in this Manual, but vehicle manufacturers make alterations and design changes during the production run of a particular vehicle of which they do not inform us. No liability can be accepted by the authors or publishers for loss, damage or injury caused by any errors in, or omissions from the information given.

Working on your car can be dangerous. This page shows just some of the potential risks and hazards, with the aim of creating a safety-conscious attitude.

## General hazards

### Scalding

- Don't remove the radiator or expansion tank cap while the engine is hot.
- Engine oil, automatic transmission fluid or power steering fluid may also be dangerously hot if the engine has recently been running.

### Burning

- Beware of burns from the exhaust system and from any part of the engine. Brake discs and drums can also be extremely hot immediately after use.

### Crushing

- When working under or near a raised vehicle, always supplement the jack with axle stands, or use drive-on ramps.

### Never venture

*under a car which is only supported by a jack.*

- Take care if loosening or tightening high-torque nuts when the vehicle is on stands. Initial loosening and final tightening should be done with the wheels on the ground.

### Fire

- Fuel is highly flammable; fuel vapour is explosive.
- Don't let fuel spill onto a hot engine.
- Do not smoke or allow naked lights (including pilot lights) anywhere near a vehicle being worked on. Also beware of creating sparks (electrically or by use of tools).
- Fuel vapour is heavier than air, so don't work on the fuel system with the vehicle over an inspection pit.
- Another cause of fire is an electrical overload or short-circuit. Take care when repairing or modifying the vehicle wiring.
- Keep a fire extinguisher handy, of a type suitable for use on fuel and electrical fires.

### Electric shock

- Ignition HT voltage can be dangerous, especially to people with heart problems or a pacemaker. Don't work on or near the ignition system with the engine running or the ignition switched on.

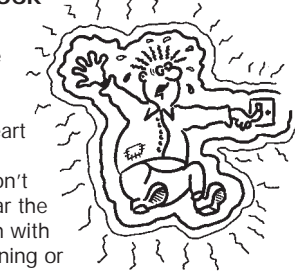

- Mains voltage is also dangerous. Make sure that any mains-operated equipment is correctly earthed. Mains power points should be protected by a residual current device (RCD) circuit breaker.

### Fume or gas intoxication

- Exhaust fumes are poisonous; they often contain carbon monoxide, which is rapidly fatal if inhaled. Never run the engine in a confined space such as a garage with the doors shut.

- Fuel vapour is also poisonous, as are the vapours from some cleaning solvents and paint thinners.

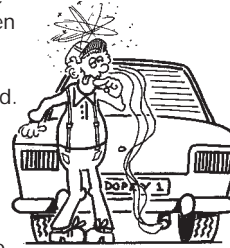

### Poisonous or irritant substances

- Avoid skin contact with battery acid and with any fuel, fluid or lubricant, especially antifreeze, brake hydraulic fluid and Diesel fuel. Don't syphon them by mouth. If such a substance is swallowed or gets into the eyes, seek medical advice.
- Prolonged contact with used engine oil can cause skin cancer. Wear gloves or use a barrier cream if necessary. Change out of oil-soaked clothes and do not keep oily rags in your pocket.
- Air conditioning refrigerant forms a poisonous gas if exposed to a naked flame (including a cigarette). It can also cause skin burns on contact.

### Asbestos

- Asbestos dust can cause cancer if inhaled or swallowed. Asbestos may be found in gaskets and in brake and clutch linings. When dealing with such components it is safest to assume that they contain asbestos.

## Special hazards

### Hydrofluoric acid

• This extremely corrosive acid is formed when certain types of synthetic rubber, found in some O-rings, oil seals, fuel hoses etc, are exposed to temperatures above 400°C. The rubber changes into a charred or sticky substance containing the acid. *Once formed, the acid remains dangerous for years. If it gets onto the skin, it may be necessary to amputate the limb concerned.*

- When dealing with a vehicle which has suffered a fire, or with components salvaged from such a vehicle, wear protective gloves and discard them after use.

### The battery

- Batteries contain sulphuric acid, which attacks clothing, eyes and skin. Take care when topping-up or carrying the battery.
- The hydrogen gas given off by the battery is highly explosive. Never cause a spark or allow a naked light nearby. Be careful when connecting and disconnecting battery chargers or jump leads.

### Air bags

- Air bags can cause injury if they go off accidentally. Take care when removing the steering wheel and/or facia. Special storage instructions may apply.

### Diesel injection equipment

- Diesel injection pumps supply fuel at very high pressure. Take care when working on the fuel injectors and fuel pipes.



**Warning:** *Never expose the hands, face or any other part of the body to injector spray; the fuel can penetrate the skin with potentially fatal results.*

## Remember...

### DO

- Do use eye protection when using power tools, and when working under the vehicle.
- Do wear gloves or use barrier cream to protect your hands when necessary.
- Do get someone to check periodically that all is well when working alone on the vehicle.
- Do keep loose clothing and long hair well out of the way of moving mechanical parts.
- Do remove rings, wristwatch etc, before working on the vehicle – especially the electrical system.
- Do ensure that any lifting or jacking equipment has a safe working load rating adequate for the job.

### DON'T

- Don't attempt to lift a heavy component which may be beyond your capability – get assistance.
- Don't rush to finish a job, or take unverified short cuts.
- Don't use ill-fitting tools which may slip and cause injury.
- Don't leave tools or parts lying around where someone can trip over them. Mop up oil and fuel spills at once.
- Don't allow children or pets to play in or near a vehicle being worked on.



## 0•6 Roadside repairs

The following pages are intended to help in dealing with common roadside emergencies and breakdowns. You will find more detailed fault finding information at the back of the manual, and repair information in the main chapters.

### If your car won't start and the starter motor doesn't turn

- If it's a model with automatic transmission, make sure the selector is in 'P' or 'N'.
- Open the bonnet and make sure that the battery terminals are clean and tight.
- Switch on the headlights and try to start the engine. If the headlights go very dim when you're trying to start, the battery is probably flat. Get out of trouble by jump starting (see next page) using a friend's car.



**A** Check that the HT lead connections at the distributor are clean and make sure they are secure by pushing them onto the cap.



**B** Check that the HT lead connections at the spark plugs are secure by pushing them onto the plugs.



**C** Check that the LT lead connections are clean and secure.

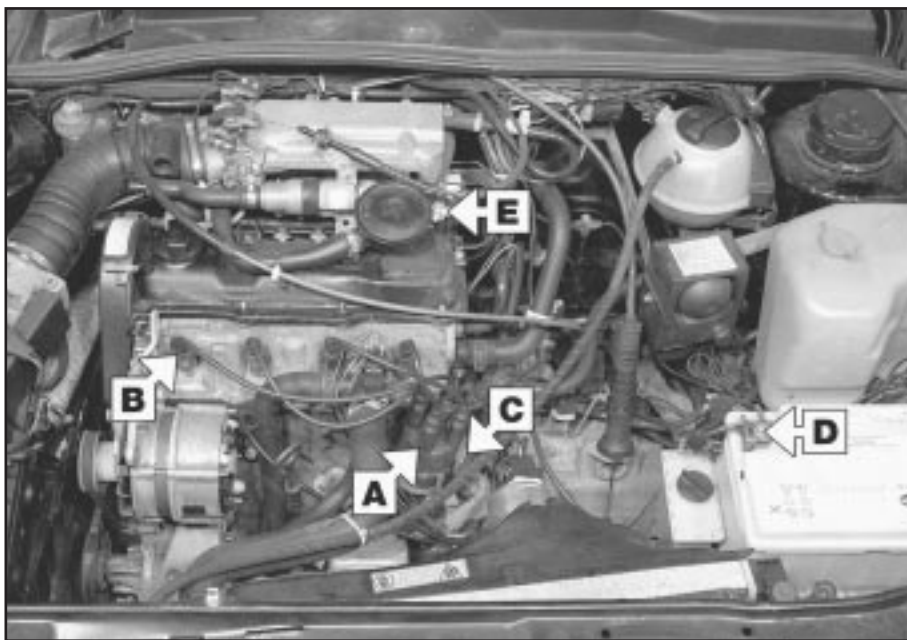

Check that electrical connections are secure (with the ignition switched off) and spray them with a water dispersant spray like WD40 if you suspect a problem due to damp



**D** Check the security and condition of the battery connections.



**E** Wiring plugs may cause problems if dirty or not connected properly.

### If your car won't start even though the starter motor turns as normal

- Is there fuel in the tank?
- Is there moisture on electrical components under the bonnet? Switch off the ignition, then wipe off any obvious dampness with a dry cloth. Spray a water-repellent aerosol product (WD-40 or equivalent) on ignition and fuel system electrical connectors like those shown in the photos. Pay special attention to the ignition coil wiring connector and HT leads.

**HAYNES**  
**HINT**

*Jump starting will get you out of trouble, but you must correct whatever made the battery go flat in the first place. There are three possibilities:*

- 1** *The battery has been drained by repeated attempts to start, or by leaving the lights on.*
- 2** *The charging system is not working properly (alternator drivebelt slack or broken, alternator wiring fault or alternator itself faulty).*
- 3** *The battery itself is at fault (electrolyte low, or battery worn out).*

When jump-starting a car using a booster battery, observe the following precautions:

- ✓ Before connecting the booster battery, make sure that the ignition is switched off.
- ✓ Ensure that all electrical equipment (lights, heater, wipers, etc) is switched off.

## Jump starting

- ✓ Make sure that the booster battery is the same voltage as the discharged one in the vehicle.
- ✓ If the battery is being jump-started from the battery in another vehicle, the two vehicles **MUST NOT TOUCH** each other.
- ✓ Make sure that the transmission is in neutral (or PARK, in the case of automatic transmission).



**1** Connect one end of the red jump lead to the positive (+) terminal of the flat battery



**2** Connect the other end of the red lead to the positive (+) terminal of the booster battery.



**3** Connect one end of the black jump lead to the negative (-) terminal of the booster battery

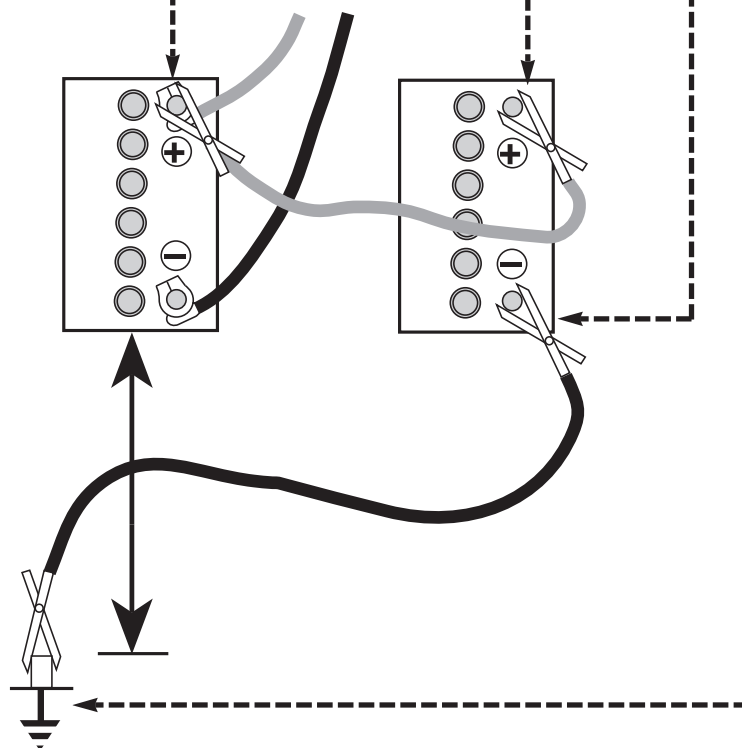

**4** Connect the other end of the black jump lead to a bolt or bracket on the engine block, well away from the battery, on the vehicle to be started.

**5** Make sure that the jump leads will not come into contact with the fan, drivebelts or other moving parts of the engine.

**6** Start the engine using the booster battery, then with the engine running at idle speed, disconnect the jump leads in the reverse order of connection.

### Wheel changing

Some of the details shown here will vary according to model. For instance, the location of the spare wheel and jack is not the same on all cars. However, the basic principles apply to all vehicles.



**Warning:** Do not change a wheel in a situation where you risk being hit by another vehicle. On busy roads, try to stop in a lay-by or a gateway. Be wary of passing traffic while changing the wheel - it is easy to become distracted by the job in hand.

#### Preparation

- When a puncture occurs, stop as soon as it is safe to do so.
- Park on firm level ground, if possible, and well out of the way of other traffic.
- Use hazard warning lights if necessary.
- If you have one, use a warning triangle to alert other drivers of your presence.
- Apply the handbrake and engage first or reverse gear (or Park on models with automatic transmission).
- Chock the wheel diagonally opposite the one being removed – a couple of large stones will do for this.
- If the ground is soft, use a flat piece of wood to spread the load under the jack.

#### Changing the wheel



**1** The spare wheels and tools are stored in the luggage compartment. Release the retaining strap and lift out the jack and tools from the centre of the wheel.



**2** Unscrew the retaining nut and lift the wheel out of the vehicle.



**3** Remove the wheel trim/hub cap from the wheel (some trims have retaining screws which must be undone first). Slacken each wheel bolt by half a turn.



**4** Locate the jack below the reinforced point on the sill and on firm ground. Turn the jack handle to raise the car until the wheel is clear of the ground.



**5** Unscrew the wheel bolts and remove the wheel. Fit the spare wheel and screw in the wheel bolts. Lightly tighten them using the wheelbrace, then lower the car to the ground.



**6** Once the car is on the ground, tighten the wheel bolts securely in a diagonal pattern using the wheelbrace. At the earliest possible opportunity, have the wheel bolts slackened and then tightened to the correct torque wrench setting.

#### Finally...

- Remove the wheel chocks.
- Stow the jack and tools in the correct locations in the car.
- Check the tyre pressure on the wheel just fitted. If it is low, or if you don't have a pressure gauge with you, drive slowly to the nearest garage and inflate the tyre to the right pressure.
- Have the damaged tyre or wheel repaired as soon as possible.



## Identifying leaks

Puddles on the garage floor or drive, or obvious wetness under the bonnet or underneath the car, suggest a leak that needs investigating. It can sometimes be difficult to decide where the leak is coming from, especially if the engine bay is very dirty already. Leaking oil or fluid can also be blown rearwards by the passage of air under the car, giving a false impression of where the problem lies.



**Warning:** Most automotive oils and fluids are poisonous. Wash them off skin, and change out of contaminated clothing, without delay.



*The smell of a fluid leaking from the car may provide a clue to what's leaking. Some fluids are distinctively coloured. It may help to clean the car carefully and to park it over some clean paper overnight as an aid to locating the source of the leak.*

*Remember that some leaks may only occur while the engine is running.*

### Sump oil



Engine oil may leak from the drain plug...

### Oil from filter



...or from the base of the oil filter.

### Gearbox oil

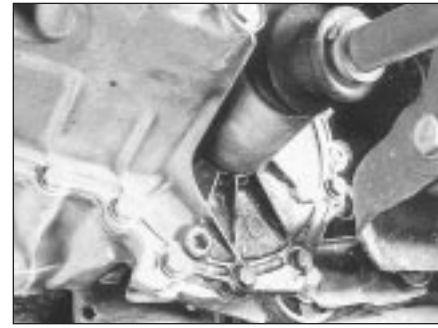

Gearbox oil can leak from the seals at the inboard ends of the driveshafts.

### Antifreeze



Leaking antifreeze often leaves a crystalline deposit like this.

### Brake fluid



A leak occurring at a wheel is almost certainly brake fluid.

### Power steering fluid

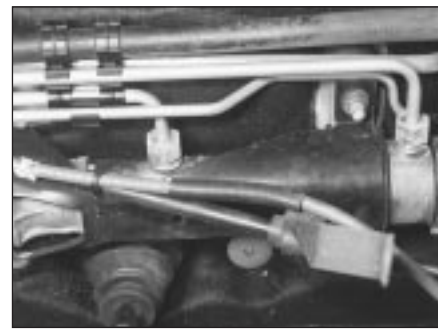

Power steering fluid may leak from the pipe connectors on the steering rack.

## Towing

When all else fails, you may find yourself having to get a tow home – or of course you may be helping somebody else. Long-distance recovery should only be done by a garage or breakdown service. For shorter distances, DIY towing using another car is easy enough, but observe the following points:

- Use a proper tow-rope – they are not expensive. The vehicle being towed must display an 'ON TOW' sign in its rear window.
- Always turn the ignition key to the 'on' position when the vehicle is being towed, so

that the steering lock is released, and that the direction indicator and brake lights will work.

- Only attach the tow-rope to the towing eyes provided.
- Before being towed, release the handbrake and select neutral on the transmission.
- Note that greater-than-usual pedal pressure will be required to operate the brakes, since the vacuum servo unit is only operational with the engine running.
- On models with power steering, greater-than-usual steering effort will also be required.

The driver of the car being towed must keep the tow-rope taut at all times to avoid snatching.

- Make sure that both drivers know the route before setting off.
- Only drive at moderate speeds and keep the distance towed to a minimum. Drive smoothly and allow plenty of time for slowing down at junctions.
- On models with automatic transmission, special precautions apply. If in doubt, do not tow, or transmission damage may result.

## Introduction

---

There are some very simple checks which need only take a few minutes to carry out, but which could save you a lot of inconvenience and expense.

These "Weekly checks" require no great skill or special tools, and the small amount of time they take to perform could prove to be very well spent, for example;

Keeping an eye on tyre condition and pressures, will not only help to stop them wearing out prematurely, but could also save your life.

Many breakdowns are caused by electrical problems. Battery-related faults are particularly common, and a quick check on a regular basis will often prevent the majority of these.

If your car develops a brake fluid leak, the first time you might know about it is when your brakes don't work properly. Checking the level regularly will give advance warning of this kind of problem.

If the oil or coolant levels run low, the cost of repairing any engine damage will be far greater than fixing the leak, for example.

## Underbonnet check points

---

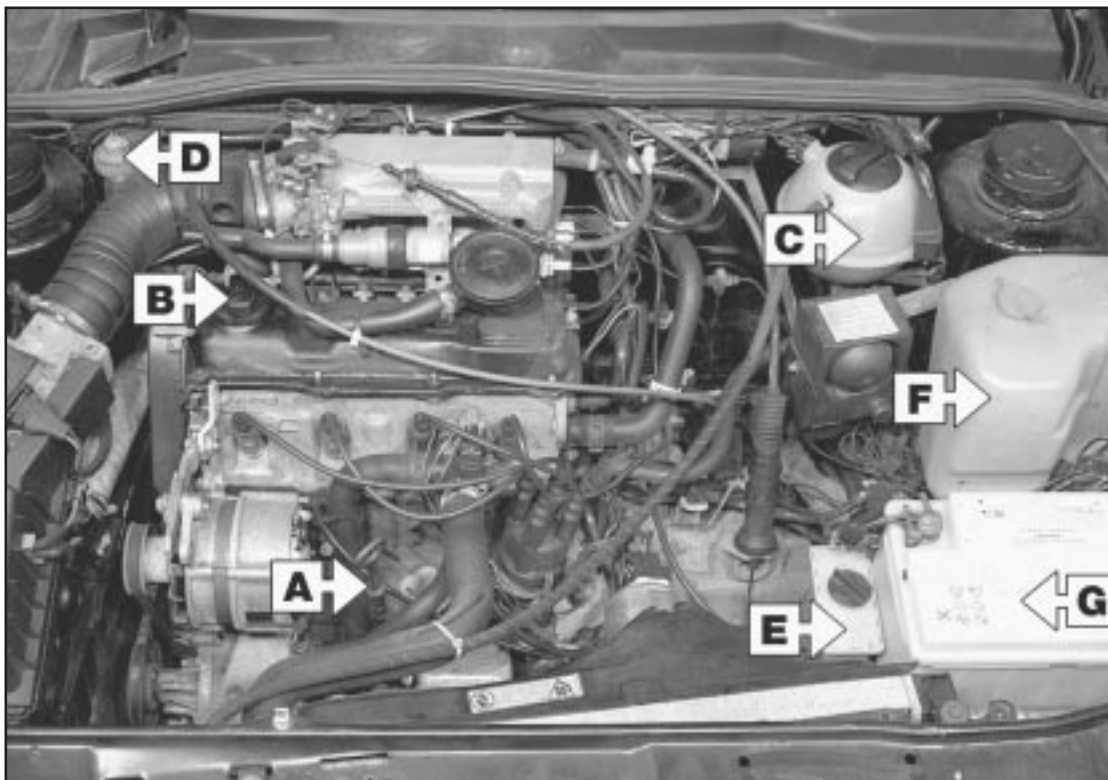

### ◀ All models (typical)

- A** Engine oil level dipstick
- B** Engine oil filler cap
- C** Coolant expansion tank
- D** Brake fluid reservoir
- E** Power steering fluid reservoir
- F** Screen washer fluid reservoir
- G** Battery

## Engine oil level

### Before you start

- ✓ Make sure that your car is on level ground.
- ✓ Check the oil level before the car is driven, or at least 5 minutes after the engine has been switched off.

**HAYNES HINT** *If the oil is checked immediately after driving the vehicle, some of the oil will remain in the upper engine components, resulting in an inaccurate reading on the dipstick!*

### The correct oil

Modern engines place great demands on their oil. It is very important that the correct oil for your car is used (See "Lubricants, fluids and capacities").

### Car Care

- If you have to add oil frequently, you should check whether you have any oil leaks. Place some clean paper under the car overnight, and check for stains in the morning. If there are no leaks, the engine may be burning oil (see "Fault Finding").

- Always maintain the level between the upper and lower dipstick marks (see photo 3). If the level is too low severe engine damage may occur. Oil seal failure may result if the engine is overfilled by adding too much oil.



**1** The dipstick is located at the right-hand end of the engine (see "Underbonnet check points" on page 0•10 for exact location). Withdraw the dipstick.



**2** Using a clean rag or paper towel remove all oil from the dipstick. Insert the clean dipstick into the tube as far as it will go, then withdraw it again.

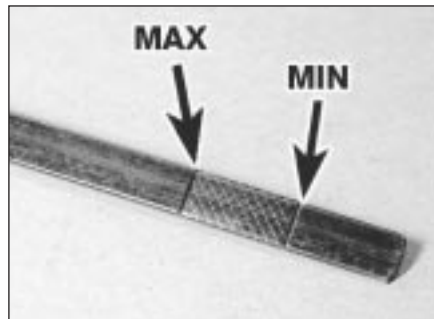

**3** Note the oil level on the end of the dipstick, which should be between the upper ("MAX") mark and lower ("MIN") mark. Approximately 1.0 litre of oil will raise the level from the lower mark to the upper mark.



**4** Oil is added through the filler cap. Unscrew the cap and top-up the level; a funnel may help to reduce spillage. Add the oil slowly, checking the level on the dipstick often. Don't overfill (see "Car Care" left).

## Coolant level



**Warning:** *DO NOT attempt to remove the expansion tank pressure cap when the engine is hot, as there is a very great risk of scalding. Do not leave open containers of coolant about, as it is poisonous.*

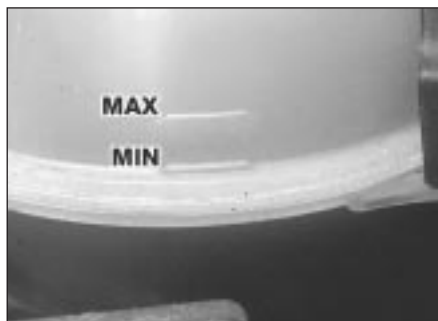

**1** The coolant level varies with the temperature of the engine. When the engine is cold, the coolant level should be between the MAX and MIN marks on the side of the expansion tank. When the engine is hot, the level may rise slightly.

### Car Care

- With a sealed-type cooling system, adding coolant should not be necessary on a regular basis. If frequent topping-up is required, it is likely there is a leak. Check the radiator, all hoses and joint faces for signs of staining or wetness, and rectify as necessary.



**2** If topping up is necessary, **wait until the engine is cold**. Slowly unscrew the expansion tank cap, to release any pressure present in the cooling system, and remove it.

- It is important that antifreeze is used in the cooling system all year round, not just during the winter months. Don't top-up with water alone, as the antifreeze will become too diluted.



**3** Add the recommended mixture of water and antifreeze through the expansion tank filler neck, until the coolant is up to the MAX level mark. Refit the cap, turning it clockwise as far as it will go until it is secure.



## Brake fluid level



**Warning:**

- Brake fluid can harm your eyes and damage painted surfaces, so use extreme caution when handling and pouring it.
- Do not use fluid that has been standing open for some time, as it absorbs moisture from the air, which can cause a dangerous loss of braking effectiveness.



- Make sure that your car is on level ground.
- The fluid level in the reservoir will drop slightly as the brake pads wear down, but the fluid level must never be allowed to drop below the "MIN" mark.

### Safety First!

- If the reservoir requires repeated topping-up this is an indication of a fluid leak somewhere in the system, which should be investigated immediately.
- If a leak is suspected, the car should not be driven until the braking system has been checked. Never take any risks where brakes are concerned.



**1** The "MAX" and "MIN" marks are indicated on the front of the reservoir. The fluid level must be kept between the marks at all times.



**2** If topping-up is necessary, first wipe clean the area around the filler cap to prevent dirt entering the hydraulic system.



**3** Unscrew the reservoir cap and carefully lift it out of position, taking care not to damage the level switch float. Inspect the reservoir, if the fluid is dirty the hydraulic system should be drained and refilled (see Chapter 1).



**4** Carefully add fluid, taking care not to spill it onto the surrounding components. Use only the specified fluid; mixing different types can cause damage to the system. After topping-up to the correct level, securely refit the cap and wipe off any spilt fluid.

## Power steering fluid level

### Before you start:

- ✓ Park the vehicle on level ground.
- ✓ Set the steering wheel straight-ahead.
- ✓ The engine should be turned off.



*For the check to be accurate, the steering must not be turned once the engine has been stopped.*

### Safety First!

- The need for frequent topping-up indicates a leak, which should be investigated immediately.



**1** The fluid reservoir is mounted next to the battery in the engine compartment. "MAX" and "MIN" level marks are indicated on the side of the reservoir. The fluid level should be maintained between these marks at all times.



**2** If topping-up is necessary, first wipe the area around the filler cap with a clean rag before removing the cap. When adding fluid, pour it carefully into the reservoir to avoid spillage. Be sure to use only the specified fluid.



**3** After filling the reservoir to the proper level, make sure that the cap is refitted securely to avoid leaks and the entry of foreign matter into the reservoir.

## Screen/headlamp washer fluid level

Screenwash additives not only keep the windscreen clean during foul weather, they also prevent the washer system freezing in cold

weather - which is when you are likely to need it most. Don't top up using plain water as the screenwash will become too diluted, and will

freeze during cold weather. **On no account use coolant antifreeze in the washer system - this could discolour or damage paintwork.**



**1** The reservoir for the windscreen and headlamp washer systems is located on the left-hand side of the engine compartment, forward of the suspension turret. The rear screen washer system reservoir is located on the right-hand side rear corner of the luggage compartment. Later systems have a single reservoir located in the engine compartment.



**2** When topping-up the reservoir(s) a screenwash additive should be added in the quantities recommended on the bottle.

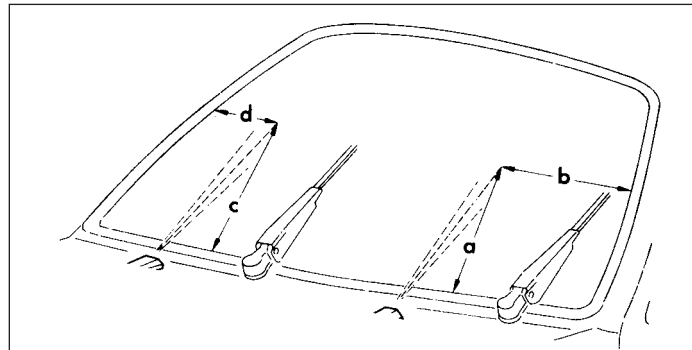

**3** Check the operation of both screen and headlamp washers. Adjust the nozzles using a pin if necessary, aiming the spray to a point slightly above the centre of the swept area.

a = 345 mm

b = 420 mm

c = 320 mm

d = 300 mm

## Wiper blades

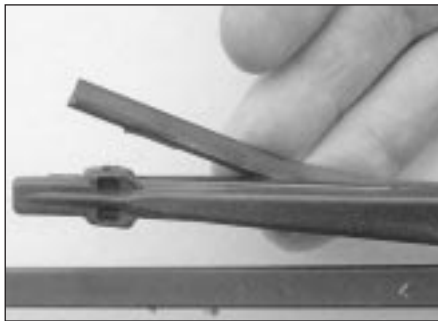

**1** Check the condition of the wiper blades; if they are cracked or show any signs of deterioration, or if the glass swept area is smeared, renew them. Wiper blades should be renewed annually.



**2** To remove a windscreen wiper blade, pull the arm fully away from the screen until it locks. Swivel the blade through 90°, press the locking tab with your fingers and slide the blade out of the arm's hooked end.



**3** Don't forget to check the tailgate wiper blade as well. To remove the blade, depress the retaining tab and slide the blade out of the hooked end of the arm.



## Tyre condition and pressure

It is very important that tyres are in good condition, and at the correct pressure - having a tyre failure at any speed is highly dangerous. Tyre wear is influenced by driving style - harsh braking and acceleration, or fast cornering, will all produce more rapid tyre wear. As a general rule, the front tyres wear out faster than the rears. Interchanging the tyres from front to rear ("rotating" the tyres) may result in more even wear. However, if this is completely effective, you may have the expense of replacing all four tyres at once! Remove any nails or stones embedded in the tread before they penetrate the tyre to cause deflation. If removal of a nail does reveal that

the tyre has been punctured, refit the nail so that its point of penetration is marked. Then immediately change the wheel, and have the tyre repaired by a tyre dealer. Regularly check the tyres for damage in the form of cuts or bulges, especially in the sidewalls. Periodically remove the wheels, and clean any dirt or mud from the inside and outside surfaces. Examine the wheel rims for signs of rusting, corrosion or other damage. Light alloy wheels are easily damaged by "kerbing" whilst parking; steel wheels may also become dented or buckled. A new wheel is very often the only way to overcome severe damage.

New tyres should be balanced when they are fitted, but it may become necessary to re-balance them as they wear, or if the balance weights fitted to the wheel rim should fall off. Unbalanced tyres will wear more quickly, as will the steering and suspension components. Wheel imbalance is normally signified by vibration, particularly at a certain speed (typically around 50 mph). If this vibration is felt only through the steering, then it is likely that just the front wheels need balancing. If, however, the vibration is felt through the whole car, the rear wheels could be out of balance. Wheel balancing should be carried out by a tyre dealer or garage.

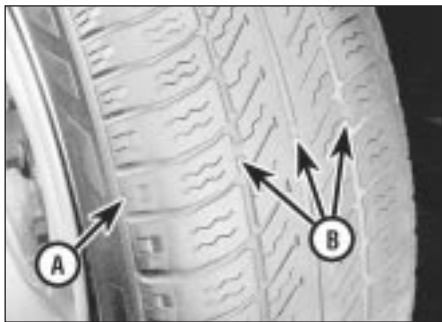

### 1 Tread Depth - visual check

The original tyres have tread wear safety bands (B), which will appear when the tread depth reaches approximately 1.6 mm. The band positions are indicated by a triangular mark on the tyre sidewall (A).



### 2 Tread Depth - manual check

Alternatively, tread wear can be monitored with a simple, inexpensive device known as a tread depth indicator gauge.



### 3 Tyre Pressure Check

Check the tyre pressures regularly with the tyres cold. Do not adjust the tyre pressures immediately after the vehicle has been used, or an inaccurate setting will result.

## Tyre tread wear patterns



### Shoulder Wear

#### Underinflation (wear on both sides)

Under-inflation will cause overheating of the tyre, because the tyre will flex too much, and the tread will not sit correctly on the road surface. This will cause a loss of grip and excessive wear, not to mention the danger of sudden tyre failure due to heat build-up.

*Check and adjust pressures*

#### Incorrect wheel camber (wear on one side)

*Repair or renew suspension parts*

#### Hard cornering

*Reduce speed!*



### Centre Wear

#### Overinflation

Over-inflation will cause rapid wear of the centre part of the tyre tread, coupled with reduced grip, harsher ride, and the danger of shock damage occurring in the tyre casing.

*Check and adjust pressures*

*If you sometimes have to inflate your car's tyres to the higher pressures specified for maximum load or sustained high speed, don't forget to reduce the pressures to normal afterwards.*



### Uneven Wear

Front tyres may wear unevenly as a result of wheel misalignment. Most tyre dealers and garages can check and adjust the wheel alignment (or "tracking") for a modest charge.

#### Incorrect camber or castor

*Repair or renew suspension parts*

#### Malfunctioning suspension

*Repair or renew suspension parts*

#### Unbalanced wheel

*Balance tyres*

#### Incorrect toe setting

*Adjust front wheel alignment*

**Note:** *The feathered edge of the tread which typifies toe wear is best checked by feel.*

## Battery

**Caution:** Before carrying out any work on the vehicle battery, read the precautions given in "Safety first" at the start of this manual.

✓ Make sure that the battery tray is in good condition, and that the clamp is tight. Corrosion on the tray, retaining clamp and the battery itself can be removed with a solution of water and baking soda. Thoroughly rinse all cleaned areas with water. Any metal parts damaged by corrosion should be covered with a zinc-based primer, then painted.

✓ Periodically (approximately every three months), check the charge condition of the battery as described in Chapter 5A.

✓ If the battery is flat, and you need to jump start your vehicle, see *Roadside Repairs*.



**1** The battery is located on the left-hand side of the engine compartment. The exterior of the battery should be inspected periodically for damage such as a cracked case or cover.

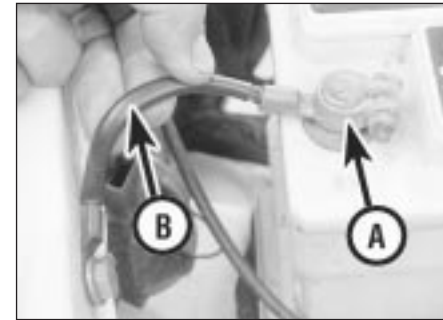

**2** Check the tightness of battery clamps (A) to ensure good electrical connections. You should not be able to move them. Also check each cable (B) for cracks and frayed conductors.



*Battery corrosion can be kept to a minimum by applying a layer of petroleum jelly to the clamps and terminals after they are reconnected.*



**3** If corrosion (white, fluffy deposits) is evident, remove the cables from the battery terminals, clean them with a small wire brush, then refit them. Automotive stores sell a tool for cleaning the battery post . . .



**4** . . . as well as the battery cable clamps

## Electrical systems

✓ Check all external lights and the horn. Refer to the appropriate Sections of Chapter 12 for details if any of the circuits are found to be inoperative.



**1** If a single indicator light, stop-light or headlight has failed, it is likely that a bulb has blown and will need to be replaced. Refer to Chapter 12 for details. If both stop-lights have failed, it is possible that the switch has failed.

✓ Visually check all accessible wiring connectors, harnesses and retaining clips for security, and for signs of chafing or damage.



**2** If more than one indicator light or tail light has failed it is likely that either a fuse has blown or that there is a fault in the circuit (see Chapter 12). The fuses are located under the fascia panel, on the right-hand side, behind a removable cover.

**HAYNES HINT**

*If you need to check your brake lights and indicators unaided, back up to a wall or garage door and operate the lights. The reflected light should show if they are working properly.*



**3** To replace a blown fuse, simply pull it out and fit a new fuse of the correct rating (see Chapter 12). If the fuse blows again, it is important that you find out why - a complete checking procedure is given in Chapter 12.

## Lubricants and fluids

<i>Component or system</i>	<i>Lubricant or fluid</i>
<b>Engine</b> .....	Multigrade engine oil to viscosity SAE 15W/50 or 20W/50 Duckhams QXR, QS, Hypergrade Plus or Hypergrade
<b>Cooling system</b> .....	Ethylene-glycol based antifreeze with corrosion inhibitors. Duckhams Antifreeze & Summer Coolant. Mixture 50% by volume
<b>Manual gearbox</b> .....	Gear oil, viscosity SAE 80 Duckhams Hypoid 80 or Hypoid 75W/90S
<b>Automatic transmission</b> .....	Dexron type ATF Duckhams Uni-Matic
<b>Final drive:</b>	
Manual gearbox .....	Gear oil, viscosity SAE 80 Duckhams Hypoid 80 or Hypoid 75W/90S
Automatic transmission .....	Gear oil, viscosity SAE 90EP Duckhams Hypoid 90S or Hypoid 75W/90S
<b>Brake hydraulic system</b> .....	Hydraulic fluid to FMVSS 11 6 DOT 4 Duckhams Universal Brake and Clutch Fluid
<b>Power steering system:</b>	
pre-April 1989 .....	Dexron type ATF Duckhams Uni-Matic
post-April 1989 .....	VW oil G 002 000 No Duckhams equivalent

## Choosing your engine oil

Oils perform vital tasks in all engines. The higher the engine's performance, the greater the demand on lubricants to minimise wear as well as optimise power and economy. Duckhams tailors lubricants to the highest technical standards, meeting and exceeding the demands of all modern engines.

### HOW ENGINE OIL WORKS

#### • *Beating friction*

Without oil, the surfaces inside your engine which rub together will heat, fuse and quickly cause engine seizure. Oil, and its special additives, forms a molecular barrier between moving parts, to stop wear and minimise heat build-up.

#### • *Cooling hot spots*

Oil cools parts that the engine's water-based coolant cannot reach, bathing the combustion chamber and pistons, where temperatures may exceed 1000°C. The oil assists in

transferring the heat to the engine cooling system. Heat in the oil is also lost by air flow over the sump, and via any auxiliary oil cooler.

#### • *Cleaning the inner engine*

Oil washes away combustion by-products (mainly carbon) on pistons and cylinders, transporting them to the oil filter, and holding the smallest particles in suspension until they are flushed out by an oil change. Duckhams oils undergo extensive tests in the laboratory, and on the road.



OIL BANK LINE  
0800 66 33 66

**Note: It is antisocial and illegal to dump oil down the drain. To find the location of your local oil recycling bank, call this number free.**

### Engine oil types

Mineral oils are the "traditional" oils, generally suited to older engines and cars not used in harsh conditions. *Duckhams Hypergrade Plus* and *Hypergrade* are well suited for use in most popular family cars. Diesel oils such as *Duckhams Diesel* are specially formulated for Diesel engines, including turbocharged models and 4x4s. Synthetic oils are the state-of-the-art in lubricants, offering ultimate protection, but at a fairly high price. One such is *Duckhams QS*, for use in ultra-high performance engines. Semi-synthetic oils offer high performance engine protection, but at less cost than full synthetic oils. *Duckhams QXR* is an ideal choice for hot hatches and hard-driven cars.

For help with technical queries on lubricants, call Duckhams Oils on 0181 290 8207



## Capacities

<i>Component or system</i>	<i>Capacity</i>
<b>Engine:</b>	
1.05 & 1.3 litre:	
rocker-finger type .....	3.0 litres with filter change 2.5 litres without filter change
hydraulic tappet type .....	3.5 litres with filter change 3.0 litres without filter change
1.6 & 1.8 litre:	
pre-August 1985 .....	3.5 litres with filter change 3.0 litres without filter change
post-August 1985 .....	4.0 litres with filter change 3.5 litres without filter change
<b>Cooling system</b> .....	6.3 litres
<b>Manual gearbox:</b>	
084 type .....	2.2 litres
085 type .....	3.1 litres
020 4-speed .....	1.5 litres
020 5-speed .....	2.0 litres
<b>Automatic transmission</b> .....	6.0 litres from dry 3.0 litres service drain & fill
<b>Final drive:</b>	
Manual gearbox .....	Included in gearbox capacity
Automatic .....	0.75 litre
<b>Fuel tank</b> .....	55.0 litres

## Tyre pressures *(tyres cold)*

	<i>Front</i>	<i>Rear</i>
<b>1.05 &amp; 1.3 litre models:</b>		
Half load .....	1.8 bar (26 lbf/in <sup>2</sup> )	1.8 bar (26 lbf/in <sup>2</sup> )
Full load .....	1.8 bar (26 lbf/in <sup>2</sup> )	2.4 bar (35 lbf/in <sup>2</sup> )
<b>1.6 &amp; 1.8 litre models:</b>		
Half load .....	2.0 bar (29 lbf/in <sup>2</sup> )	1.8 bar (26 lbf/in <sup>2</sup> )
Full load .....	2.0 bar (29 lbf/in <sup>2</sup> )	2.4 bar (35 lbf/in <sup>2</sup> )





# Chapter 1

## Routine maintenance and servicing



1

### Contents

Air cleaner element renewal . . . . .	32	Fuel filter renewal . . . . .	33
Air conditioning system check . . . . .	8	Fuel system control linkage check . . . . .	9
Alternator, power steering pump and air conditioner compressor drivebelt(s) check . . . . .	13	Gearbox oil level check . . . . .	22
Antifreeze concentration check . . . . .	14	Headlight beam alignment check . . . . .	27
Automatic transmission and final drive fluid renewal . . . . .	35	Hinge and catch lubrication . . . . .	30
Automatic transmission fluid level check . . . . .	23	Ignition timing check . . . . .	17
Battery electrolyte level check . . . . .	7	Intensive maintenance . . . . .	2
Brake check . . . . .	5	Introduction . . . . .	1
Brake fluid renewal . . . . .	36	Light, direction indicator and horn check . . . . .	10
Brake pad and rear shoe lining check . . . . .	26	Lock, hinge and latch mechanism check . . . . .	3
Clutch operation check . . . . .	21	Seat belt check . . . . .	4
Contact breaker point renewal and adjustment . . . . .	16	Slow running adjustment . . . . .	20
Contact breaker point check . . . . .	11	Spark plug renewal . . . . .	15
CV joint and boot check . . . . .	24	Steering gear check . . . . .	28
Engine oil and filter renewal . . . . .	18	Sunroof guide rails cleaning and lubrication . . . . .	34
Exhaust system check . . . . .	19	Suspension check . . . . .	29
Fluid leakage and engine electrical system check . . . . .	6	Timing belt renewal . . . . .	37
Fuel and brake line, hose and union check . . . . .	25	Valve clearance check . . . . .	12
		Vehicle underbody check . . . . .	31

### Degrees of difficulty

Easy, suitable for novice with little experience



Fairly easy, suitable for beginner with some experience



Fairly difficult, suitable for competent DIY mechanic



Difficult, suitable for experienced DIY mechanic



Very difficult, suitable for expert DIY or professional



# 1.2 Servicing specifications

## Lubricants, fluids and capacities

Refer to the end of "Weekly checks"

### Engine

Oil filter ..... Champion C101/C160

### Valve clearances

1.05 and 1.3 litre engines - pre August 1985:

Warm:

Inlet ..... 0.15 to 0.20 mm

Exhaust ..... 0.25 to 0.30 mm

Cold:

Inlet ..... 0.10 to 0.15 mm

Exhaust ..... 0.20 to 0.25 mm

### Hydraulic tappet free travel

1.05 and 1.3 litre - post August 1985, 1.6 and 1.8 litre (Maximum travel) .. 0.1 mm

### Cooling system

Antifreeze mixture ..... 50 % antifreeze (by volume) with water

### Air conditioning system

Compressor drivebelt tension ..... 5.0 to 10.0 mm deflection on longest run

### Fuel system

#### Air filter element types

Carburettor engines:

1.05 litre ..... Champion W101

1.3 litre ..... Champion W102

1.6 and 1.8 litre ..... Champion U508

Fuel-injected engines:

K-Jetronic on 16 valve engine:

1.8 litre ..... Champion U502

All other systems:

1.8 litre Golf ..... Champion U506

1.8 litre Jetta ..... Champion U502

1.8 litre GTi ( engine code RP) ..... Champion U572

#### Fuel filter element types

Carburettor engines (all models) ..... Champion L104

Fuel-injected engines:

K-Jetronic on 16 valve engine:

1.8 litre Golf ..... Champion L203

1.8 litre Jetta ..... Champion L206

All other systems:

1.8 litre GTi ( engine code RP) ..... Champion L206

All other models ..... Champion L204\*

\* New copper washers must be used and these are not supplied with the filter

### Idle speed

1.05 litre carburettor engines:

Pierburg/Solex 31 PIC-7 ..... 900 to 1000 rpm

Pierburg/Solex 1B3 and Weber 32 TLA ..... 750 to 850 rpm

1.3 litre carburettor engines:

Pierburg/Solex 2E3 ..... 750 to 850 rpm

1.6 litre carburettor engines:

Pierburg/Solex 2E2 - engine code EZ ..... 900 to 1000 rpm

Pierburg/Solex 2E2 - engine code RF ..... 700 to 800 rpm

1.8 litre carburettor engines:

Pierburg/Solex 2E2 ..... 900 to 1000 rpm

K-Jetronic fuel-injected engine:

8 valve:

Pre Sept. 1984 ..... 900 to 1000 rpm

From Sept. 1984 ..... 800 to 1000 rpm

Air conditioned models ..... 850 to 1000 rpm

16 valve ..... 900 to 1000 rpm

Mono Jetronic fuel-injected engine ..... 750 to 950 rpm (not adjustable)

Digijet fuel-injected engine:

Up to July 1989 ..... 750 to 850 rpm

July 1989 ..... 880 to 980 rpm

Digifant fuel-injected engine ..... 750 to 850 rpm