





Chapter 1

Routine maintenance and servicing

Contents

Air cleaner filter element renewal	38	Fluid leak check	10
Air cleaner inlet air temperature control check	36	Fluid level checks	3
Air conditioner refrigerant charge check	26	Ford Sierra maintenance schedule	1
Automatic transmission brake band adjustment	40	Front and rear brake pad/shoe check	9
Automatic transmission fluid level check	17	Fuel filter renewal	41
Automatic transmission selector lubrication	28	Handbrake check	24
Auxiliary drivebelt check	21	Hinge and lock check and lubrication	19
Battery electrolyte level check	6	Idle speed linkage clean	33
Battery terminal check	22	Ignition system component check	39
Brake fluid renewal	44	Introduction	2
Brake system seal and hose renewal	43	Manual gearbox oil level check	18
Brake pipe and hose check	32	Mixture adjustment check	16
Camshaft drivebelt renewal	45	Oil filler cap check	14
Crankcase ventilation system check	35	Pulse air filter element renewal	37
Crankcase ventilation vent valve renewal	42	Radiator matrix and air conditioner condenser clean	25
Driveshaft check	30	Road test	34
Electrical system check	5	Roadwheel security check	13
Engine coolant renewal	46	Seat belt check	11
Engine idle speed check	15	Spark plug renewal	20
Engine oil and filter renewal	8	Steering and suspension security check	29
Engine valve clearance check	23	Tyre checks	4
Exhaust system check	12	Underbody inspection	31
Final drive oil level check	27	Wiper blade check	7

Degrees of difficulty

Easy , suitable for novice with little experience		Fairly easy , suitable for beginner with some experience		Fairly difficult , suitable for competent DIY mechanic		Difficult , suitable for experienced DIY mechanic		Very difficult , suitable for expert DIY or professional	
--	---	---	---	---	---	--	---	---	---

Specifications

Engine

Oil filter type:	
SOHC and DOHC	Champion C102
CVH	Champion C104
Valve clearances (cold):	
SOHC:	
Inlet	0.20 ± 0.03 mm (0.008 ± 0.001 in)
Exhaust	0.25 ± 0.03 mm (0.010 ± 0.001 in)
DOHC and CVH:	
Inlet	Not applicable (hydraulic cam followers)
Exhaust	Not applicable (hydraulic cam followers)

1.2 Servicing specifications

Cooling system

Drivebelt tensions:

Air conditioning system compressor	10.0 mm (0.4 in) deflection at the midpoint of the belt's longest run under firm thumb pressure
Coolant pump/alternator	10.0 mm (0.4 in) deflection midway between coolant pump and alternator (or power steering pump) pulleys under firm thumb pressure

Fuel system

Air filter element:

Carburettor type:

1.3 and 1.6 litre (SOHC - Ford carburettor)	Champion W110
1.6 litre (SOHC - Weber carburettor) and 1.8 litre SOHC	Champion W118
1.6 litre (SOHC - 1984-on) and 2.0 litre SOHC	Champion W152
1.8 litre CVH	Champion W219
2.0 litre DOHC	Champion W152

Fuel injection type:

2.0 litre SOHC and DOHC	Champion U507
1.6 and 1.8 litre (R6A type) CVH	Champion W219

Fuel filter:

All fuel injection models	Champion L204
---------------------------	---------------

Ignition system

Spark plugs:

Make and type:

All except 1.8 CVH, CVH (R6A), 2.0 DOHC and P100	Champion RF7YCC or RF7YC
1.8 litre CVH	Champion RC7YCC or RC7YC
P100	Champion RF7YC or F7YC
1.6 and 1.8 litre (R6A type) CVH	Champion RC7YCC
2.0 litre DOHC	Champion RC7YCC

Electrode gap*:

Champion F7YCC or RC7YCC	0.8 mm (0.032 in)
Champion RF7YC, F7YC or RC7YC	0.7 mm (0.028 in)

Ignition HT leads

Resistance	30 k ohms maximum per lead
------------	----------------------------

Type:

All SOHC models	Champion LS-09 or LS-10 boxed set
1.8 litre CVH	Champion LS-10 boxed set
1.6 and 1.8 litre (R6A type) CVH	Champion LS-30 boxed set
2.0 litre DOHC	Champion LS-29 boxed set

*The spark plug gap quoted is that recommended by Champion for their specified plugs listed above. If spark plugs of any other type are to be fitted, refer to their manufacturer's recommendations.

Brakes

Brake pad friction material minimum thickness	1.5 mm (0.06 in)
Brake shoe friction material minimum thickness	1.0 mm (0.04 in)

Torque wrench settings

	Nm	lbf ft
Engine oil drain plug:		
SOHC and DOHC	21 to 28	16 to 21
CVH	20 to 30	15 to 22
Engine block coolant drain plug (where fitted)	21 to 25	16 to 18
Manual gearbox:		
Oil filler/level plug:		
A,B,C and N types	33 to 41	24 to 30
MT75 type	29 to 41	21 to 30
Oil drain plug:		
MT75 type	29 to 41	21 to 30
Final drive oil filler plug	35 to 45	26 to 33
Roadwheel nuts:		
Saloon, Hatchback and Estate models (steel and alloy wheels)	70 to 100	52 to 74
P100 models	85 to 90	63 to 66
Spark plugs:		
SOHC models	20 to 28	15 to 21
CVH models	18 to 33	13 to 24
DOHC models	15 to 21	11 to 15
Brake caliper guide bolts:		
Front	20 to 25	15 to 18
Rear	31 to 35	23 to 26

Capacities

Engine oil

SOHC engines:	
With filter	3.75 litres (6.6 pints)
Without filter	3.25 litres (5.7 pints)
DOHC engine:	
With filter	4.5 litres (7.9 pints)
Without filter	4.0 litres (7.0 pints)
1.6 litre CVH engine:	
With filter	3.5 litres (6.2 pints)
Without filter	3.25 litres (5.7 pints)
1.8 CVH engines:	
With filter	4.0 litres (7.0 pints)
Without filter	3.5 litres (6.2 pints)

Cooling system (including heater)

SOHC engines	8.0 litres (14.1 pints)
DOHC engine:	
Carburettor models	7.0 litres (12.3 pints)
Fuel injection models	7.3 litres (12.8 pints)
CVH engines:	
1.6 and 1.8 litre (R2A)	9.5 litres (16.7 pints)
1.8 litre (R6A)	7.9 litres (13.9 pints)

Fuel tank

All models except P100	60.0 litres (13.2 gals)
P100 models	66.0 litres (14.5 gals)

Manual gearbox

A1 and A2 types	0.98 litre (1.72 pints)
B type	1.46 litres (2.57 pints)
C type	1.25 litres (2.20 pints)
N type up to 1987	1.90 litres (3.34 pints)
N type from 1987	1.25 litres (2.20 pints)
MT75 type	1.2 litres (2.1 pints)

Automatic transmission

C3 type	6.3 litres (11.1 pints)
A4LD type	8.5 litres (15.0 pints)

Final drive (from dry)

All models except 1.3 and 1.6 litre Hatchback and P100	0.9 litre (1.6 pints)
1.3 and 1.6 litre Hatchback models	0.8 litre (1.4 pints)
P100 models (rear axle)	1.14 litres (2.0 pints)

Power steering

All models	0.65 litre (1.14 pints)
------------------	-------------------------

1 Ford Sierra maintenance schedule

The maintenance intervals in this manual are provided with the assumption that you will be carrying out the work yourself. These are the minimum maintenance intervals recommended by the manufacturer for vehicles driven daily. If you wish to keep your vehicle in peak condition at all times, you may

wish to perform some of these procedures more often. We encourage frequent maintenance, because it enhances the efficiency, performance and resale value of your vehicle.

If the vehicle is driven in dusty areas, used to tow a trailer, or driven frequently at slow

speeds (idling in traffic) or on short journeys, more frequent maintenance intervals are recommended.

When the vehicle is new, it should be serviced by a factory-authorised dealer service department, in order to preserve the factory warranty.

1.4 Maintenance schedule

Every 250 miles (400 km) or weekly

- Check the engine oil level (Section 3)
- Check the engine coolant level (Section 3)
- Check the brake fluid level (Section 3)
- Check the power steering fluid level (Section 3)
- Check the screen washer fluid level (Section 3)
- Visually examine the tyres for tread depth, and wear or damage (Section 4)
- Check and if necessary adjust the tyre pressures (Section 4)
- Check and if necessary top-up the battery electrolyte level - where applicable (Section 6)
- Check the operation of the horn, all lights, and the wipers and washers (Sections 5 and 7)

Every 6000 miles (10 000 km) or 6 months - whichever comes sooner

- Renew engine oil and filter (Section 8)
- Check brake pads or shoes for wear (front and rear) (Section 9)
- Check operation of brake fluid level warning indicator (Section 9)
- Inspect engine bay and underside of vehicle for fluid leaks or other signs of damage (Section 10)
- Check function and condition of seat belts (Section 11)
- Check condition and security of exhaust system (Section 12)
- Check tightness of wheel nuts (Section 13)
- Clean oil filler cap (Section 14)
- Check idle speed (where applicable) (Section 15)
- Check mixture adjustment (where applicable) (Section 16)

Every 12 000 miles (20 000 km) or 12 months - whichever comes sooner

- Check automatic transmission fluid level (engine hot) (Section 17)
- Check manual gearbox oil level (Section 18)
- Check operation of latches, check straps and locks; lubricate if necessary (Section 19)
- Renew spark plugs (Section 20)
- Check condition and tension of auxiliary drivebelt(s); adjust or renew as necessary (Section 21)
- Check tightness of battery terminals, clean and neutralise corrosion if necessary (Section 22)
- Check engine valve clearances - SOHC only (Section 23)
- Check handbrake mechanism (Section 24)

Every 12 000 miles (20 000 km) or 12 months - whichever comes sooner (continued)

- Clean radiator matrix and air conditioning condenser fins (where applicable) (Section 25)
- Check air conditioning refrigerant charge (where applicable) (Section 26)
- Check final drive oil level (Section 27)
- Lubricate automatic transmission selector/kickdown linkage (Section 28)
- Check security and condition of steering and suspension components, gaiters and boots (Section 29)
- Check condition and security of driveshaft joints and gaiters (Section 30)
- Inspect underbody and panels for corrosion or other damage (Section 31)
- Inspect brake pipes and hoses (Section 32)
- Clean idle speed control linkage at throttle (where applicable) (Section 33)
- Road test and check operation of ABS (Section 34)
- Check crankcase ventilation system (Section 35)

Every 24 000 miles (40 000 km) or 2 years - whichever comes sooner

- Check air cleaner inlet air temperature control operation (carburettor models) (Section 36)
- Renew pulse air filter element (1.6 litre CVH) (Section 37)
- Renew air cleaner element (Section 38)
- Clean and inspect distributor cap and HT leads (Section 39)
- Check automatic transmission brake band adjustment (Section 40)
- Renew fuel filter (fuel-injection models only) (Section 41)
- Renew crankcase ventilation vent valve (SOHC and DOHC) (Section 42)

Every 36 000 miles (60 000 km) or 3 years - whichever comes sooner

- Renew brake hydraulic system seals and hoses if necessary (Section 43)
- Renew brake hydraulic fluid (Section 44)
- Renew camshaft drivebelt (optional on SOHC models - compulsory on CVH) (Section 45)
- Renew coolant (Section 46)

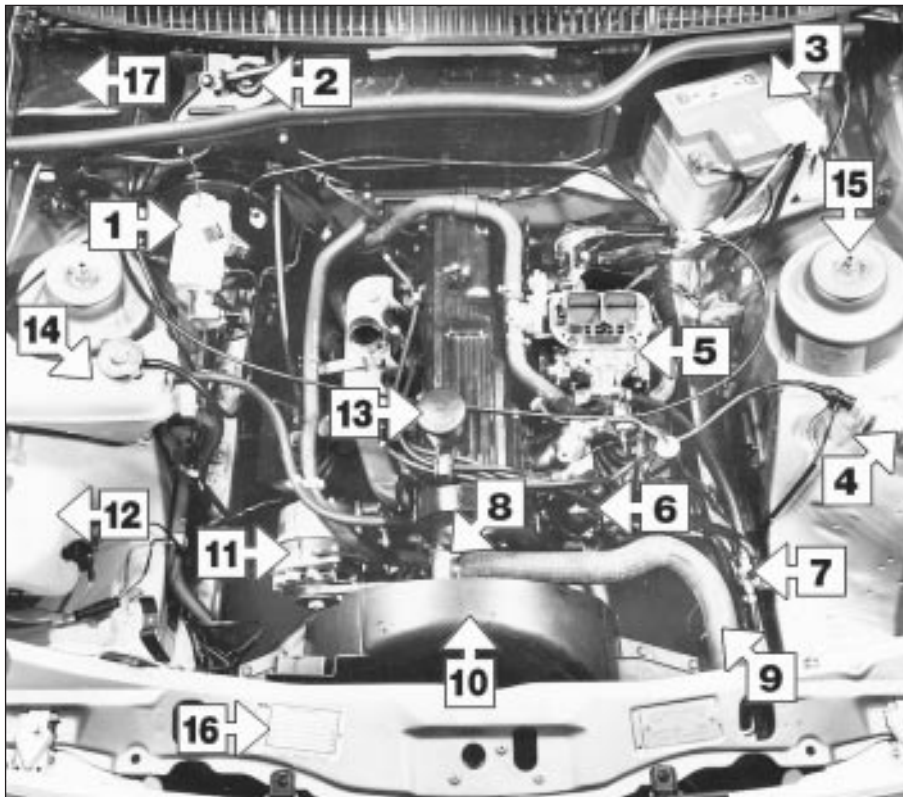

Underbonnet view of a 1983 2.0 litre SOHC carburettor model (air cleaner removed)

- 1 Brake fluid reservoir
- 2 Windscreen wiper motor
- 3 Battery
- 4 Ignition coil
- 5 Carburettor
- 6 Distributor
- 7 Fuel pressure regulator
- 8 Thermostat housing
- 9 Radiator top hose
- 10 Upper fan shroud
- 11 Alternator
- 12 Windscreen washer reservoir
- 13 Oil filler cap
- 14 Cooler expansion tank
- 15 Suspension strut top
- 16 VIN plate
- 17 Fusebox

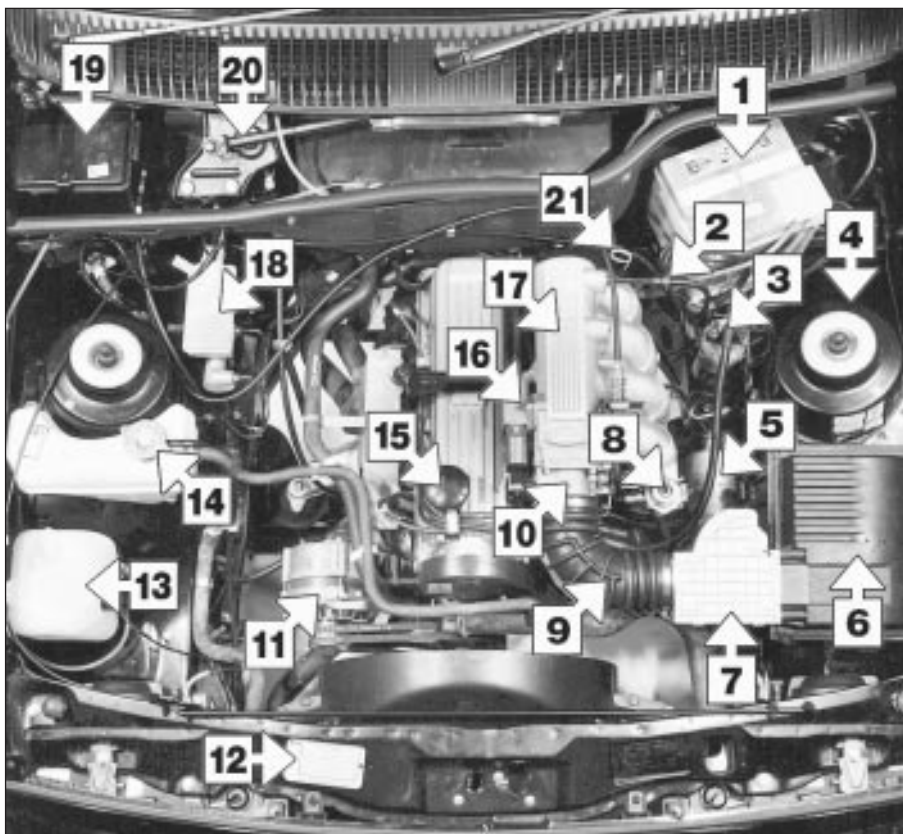

Underbonnet view of a 1985 2.0 litre SOHC fuel injection model

- 1 Battery
- 2 Brake servo non-return valve
- 3 Ignition coil
- 4 Suspension strut top
- 5 Fuel filter
- 6 Air cleaner
- 7 Airflow meter
- 8 Fuel pressure regulator
- 9 Air inlet hose
- 10 Throttle body
- 11 Alternator
- 12 VIN plate
- 13 Windscreen washer reservoir
- 14 Coolant expansion tank
- 15 Oil filler cap
- 16 Idle speed control valve
- 17 Inlet manifold
- 18 Brake fluid reservoir
- 19 Fusebox
- 20 Windscreen wiper motor
- 21 Engine oil level dipstick

1.6 Maintenance - component location

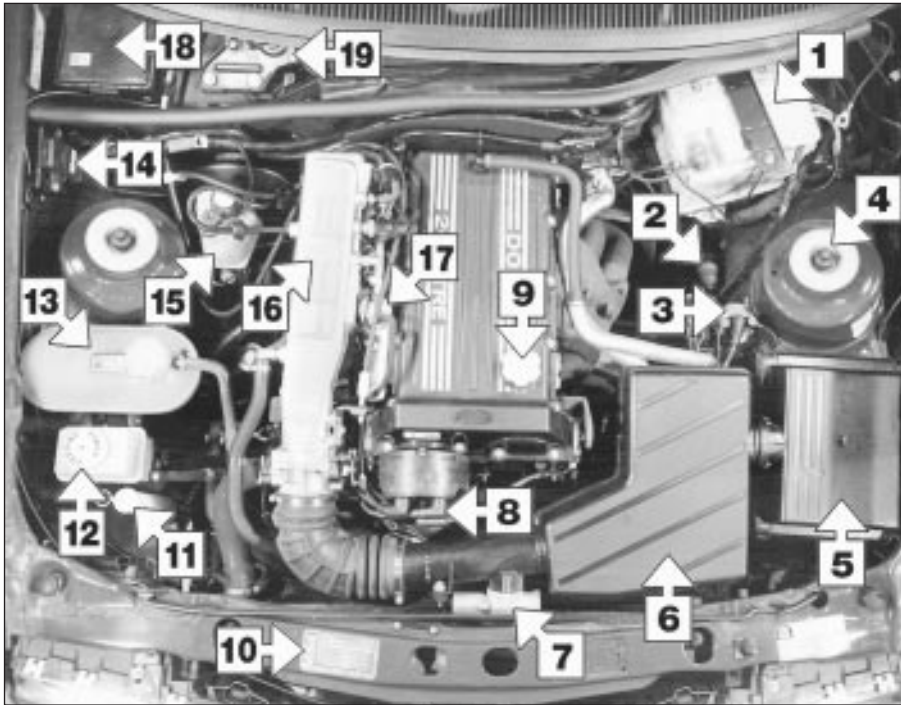

Underbonnet view of a 1990 2.0 litre DOHC fuel injection model

- 1 Battery
- 2 Braking system deceleration-sensitive valve
- 3 Ignition coil
- 4 Suspension strut top
- 5 Air cleaner
- 6 Plenum chamber
- 7 Idle speed control valve
- 8 Distributor
- 9 Oil filler cap
- 10 VIN plate
- 11 Windscreen washer reservoir filler neck
- 12 Power steering fluid reservoir
- 13 Coolant expansion tank
- 14 Manifold absolute pressure (MAP) sensor
- 15 Brake fluid reservoir
- 16 Inlet manifold
- 17 Fuel pressure regulator
- 18 Fusebox
- 19 Windscreen wiper motor

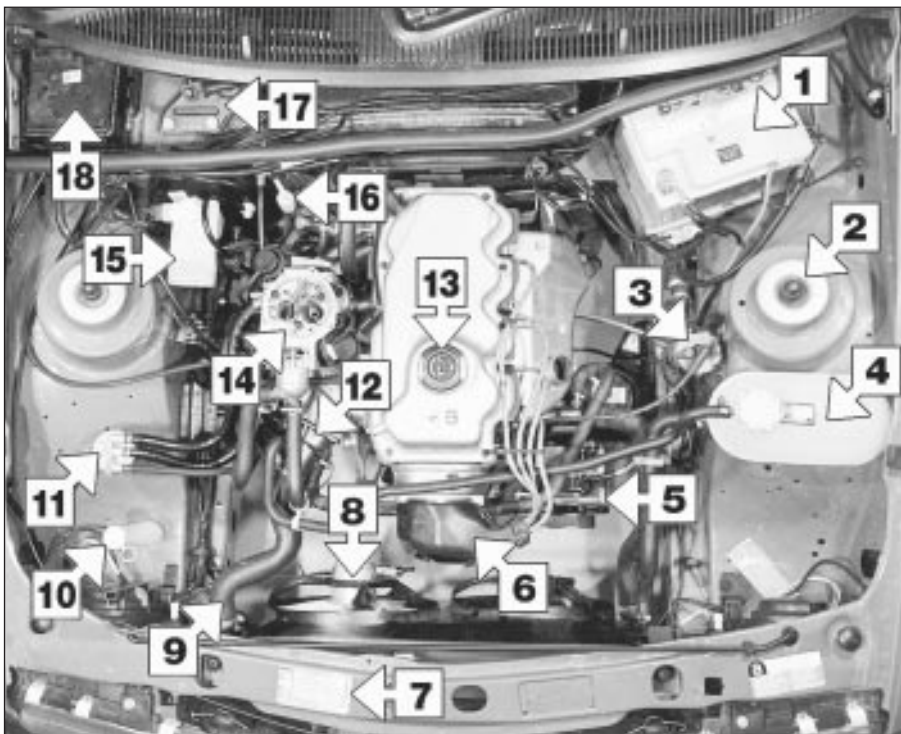

Underbonnet view of a 1989 1.8 litre (R2A) CVH model (air cleaner removed)

- 1 Battery
- 2 Suspension strut top
- 3 Ignition coil
- 4 Coolant expansion tank
- 5 Alternator
- 6 Distributor cap shroud
- 7 VIN plate
- 8 Electric cooling fan
- 9 Radiator top hose
- 10 Windscreen washer reservoir
- 11 Fuel vapour separator
- 12 Thermostat housing
- 13 Oil filler cap
- 14 Carburettor
- 15 Brake fluid reservoir
- 16 Engine oil level dipstick
- 17 Windscreen wiper motor
- 18 Fusebox

Underbonnet view of a 1992 1.6 litre CVH model (air cleaner removed)

- 1 Battery
- 2 Braking system deceleration-sensitive valve
- 3 Suspension strut top
- 4 Coolant expansion tank
- 5 Pulse-air filter
- 6 Vacuum-operated air valve
- 7 Alternator
- 8 Cooling fans
- 9 Oil filler cap
- 10 Thermostat housing
- 11 VIN plate
- 12 Windscreen washer reservoir filler neck
- 13 Ignition module
- 14 Pulse-air control solenoid
- 15 CFI unit
- 16 Brake fluid reservoir
- 17 Engine oil level dipstick
- 18 Manifold absolute pressure (MAP) Sensor
- 19 Fusebox
- 20 Windscreen wiper motor

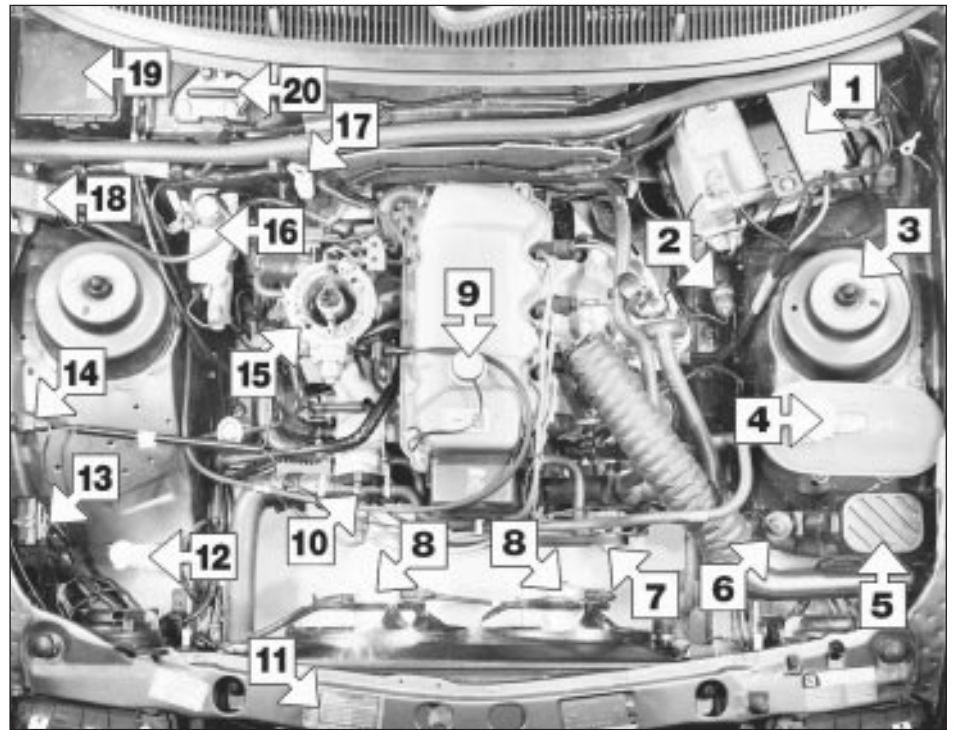

1

Front underside view of a 1990 2.0 GLS model

- 1 Horns
- 2 Tie-rod end
- 3 Tie-rod
- 4 Gaiter
- 5 Coolant pump
- 6 Suspension lower arm
- 7 Anti-roll bar
- 8 Starter motor
- 9 Exhaust downpipes
- 10 Crossmember
- 11 Engine sump
- 12 Oil filter
- 13 Power steering fluid pump
- 14 Windscreen washer reservoir
- 15 Cooling fans

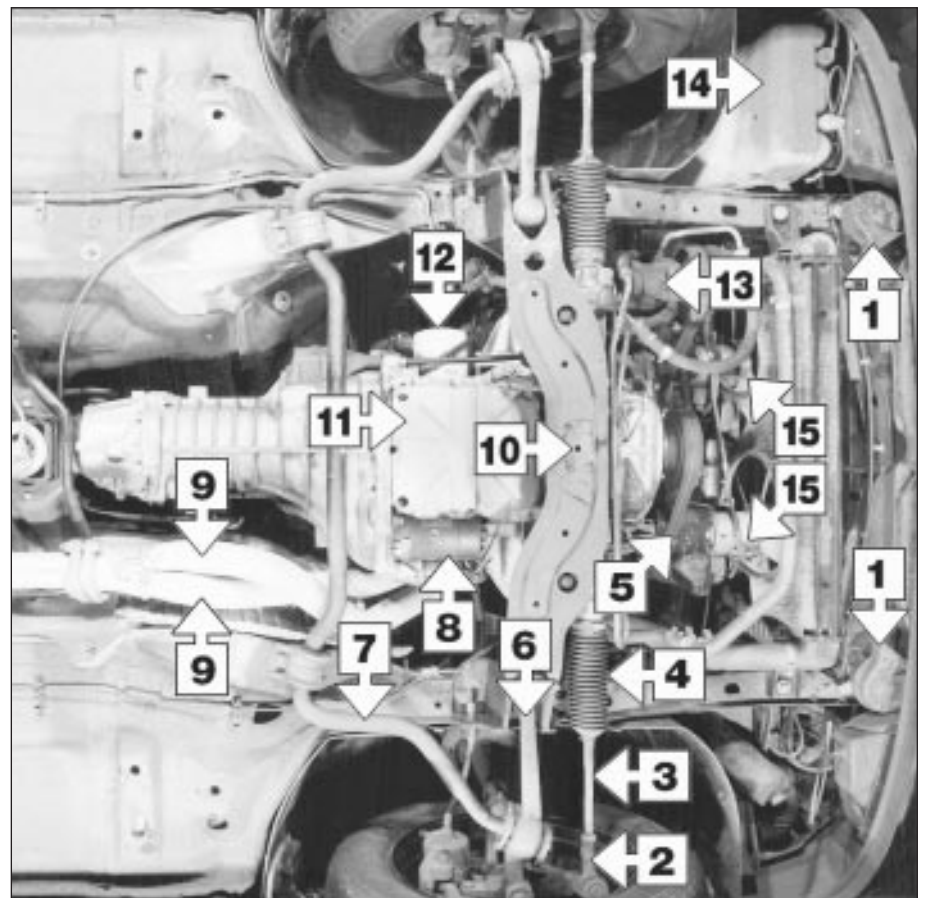

1.8 Maintenance - component location

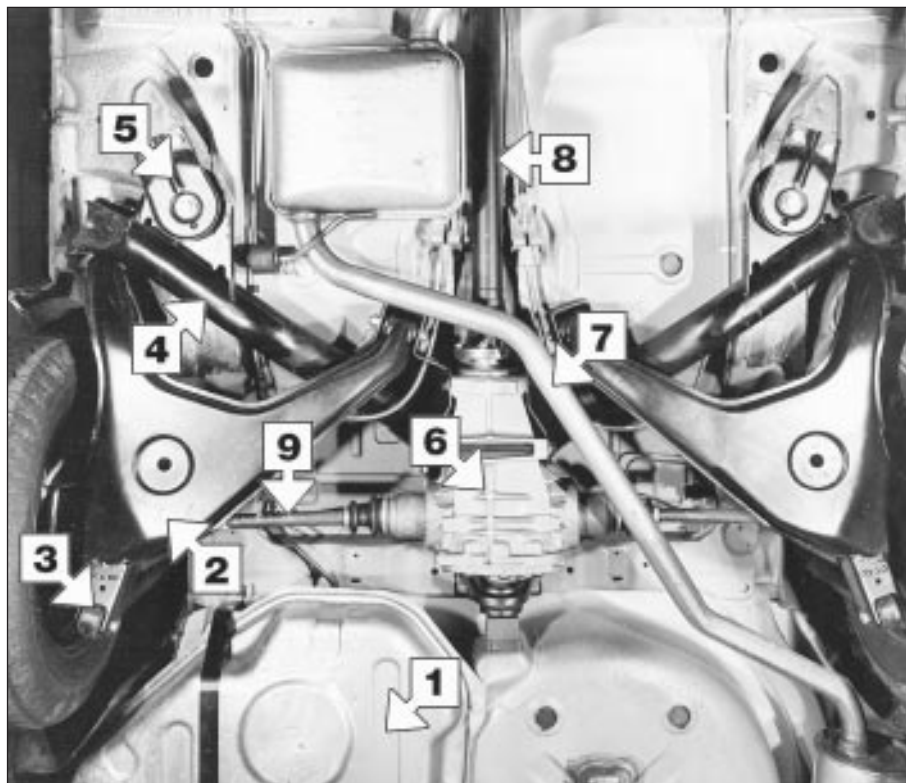

Rear underside view of a Hatchback models

- 1 Fuel tank
- 2 Suspension lower arm
- 3 Lower shock absorber mounting
- 4 Suspension crossmember
- 5 Suspension guide plate
- 6 Final drive unit
- 7 Exhaust system
- 8 Propeller shaft
- 9 Driveshaft

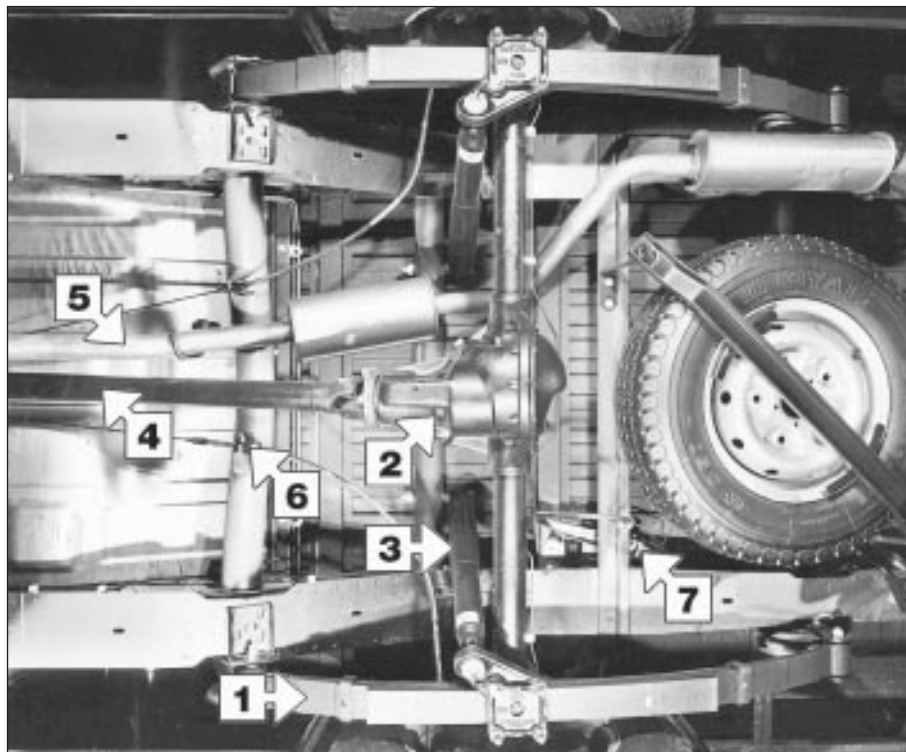

Rear underside view of a P100 model

- 1 Suspension leaf spring
- 2 Rear axle
- 3 Shock absorber
- 4 Propeller shaft
- 5 Exhaust system
- 6 Handbrake cable adjuster
- 7 Brake load apportioning valve

2 Introduction

General information

This Chapter is designed to help the home mechanic maintain his/her vehicle for safety, economy, long life and peak performance.

The Chapter contains a master maintenance schedule, followed by Sections dealing specifically with each task in the schedule. Visual checks, adjustments, component renewal and other helpful items are included. Refer to the accompanying illustrations of the engine compartment and the underside of the vehicle for the locations of the various components.

Servicing your vehicle in accordance with the mileage/time maintenance schedule and the following Sections will provide a planned maintenance programme, which should result in a long and reliable service life. This is a comprehensive plan, so maintaining some items but not others at the specified service intervals, will not produce the same results.

As you service your vehicle, you will discover that many of the procedures can - and should - be grouped together, because of the particular procedure being performed, or because of the close proximity of two otherwise-unrelated components to one another. For example, if the vehicle is raised for any reason, the exhaust can be inspected at the same time as the

suspension and steering components.

The first step in this maintenance programme is to prepare yourself before the actual work begins. Read through all the Sections relevant to the work to be carried out, then make a list and gather together all the parts and tools required. If a problem is encountered, seek advice from a parts specialist, or a dealer service department.

Intensive maintenance

If, from the time the vehicle is new, the routine maintenance schedule is followed closely, and frequent checks are made of fluid levels and high-wear items, as suggested throughout this manual, the engine will be kept in relatively good running condition, and the need for additional work will be minimised.

It is possible that there will be times when the engine is running poorly due to the lack of regular maintenance. This is even more likely if a used vehicle, which has not received regular and frequent maintenance checks, is purchased. In such cases, additional work may need to be carried out, outside of the regular maintenance intervals.

If engine wear is suspected, a compression test will provide valuable information regarding the overall performance of the main internal components. Such a test can be used as a basis to decide on the extent of the work to be carried out. If, for example, a compression test indicates serious internal engine wear, conventional maintenance as described in this Chapter will not greatly

improve the performance of the engine, and may prove a waste of time and money, unless extensive overhaul work is carried out first.

The following series of operations are those most often required to improve the performance of a generally poor-running engine:

Primary operations

- a) Clean, inspect and test the battery
- b) Check all the engine-related fluids
- c) Check the condition and tension of the auxiliary drivebelt
- d) Renew the spark plugs
- e) Inspect the distributor cap and HT leads - as applicable
- f) Check the condition of the air cleaner filter element, and renew if necessary
- g) Renew the fuel filter
- h) Check the condition of all hoses, and check for fluid leaks
- i) Check the idle speed and mixture settings - as applicable

If the above operations do not prove fully effective, carry out the following secondary operations:

Secondary operations

- a) Check the charging system
- b) Check the ignition system
- c) Check the fuel system
- d) Renew the distributor cap and rotor arm - as applicable
- f) Renew the ignition HT leads - as applicable

1

Every 250 miles (400 km) or weekly

3 Fluid level checks

See "Weekly checks".



5 Electrical system check

See "Weekly checks".



7 Wiper blade check

See "Weekly checks".



4 Tyre checks

See "Weekly checks".



6 Battery electrolyte level check

See "Weekly checks".



Every 6000 miles (10 000 km) or 6 months

8 Engine oil and filter renewal

1 Frequent oil and filter changes are the most important preventative maintenance procedures which can be undertaken by the DIY owner. As engine oil ages, it becomes diluted and contaminated, which leads to premature engine wear.

2 Before starting this procedure, gather together all the necessary tools and materials. Also make sure that you have plenty of clean rags and newspapers handy, to mop up any spills. Ideally, the engine oil should be warm, as it will drain better, and more built-up

sludge will be removed with it. Take care, however, not to touch the exhaust or any other hot parts of the engine when working under the vehicle. To avoid any possibility of scalding, and to protect yourself from possible skin irritants and other harmful contaminants in used engine oils, it is advisable to wear gloves when carrying out this work. Access to the underside of the vehicle will be greatly improved if it can be raised on a lift, driven onto ramps, or jacked up and supported on axle stands (see "Jacking and vehicle support"). Whichever method is chosen, make sure that the vehicle remains level, or if it is at an angle, so that the drain plug is at the lowest point (see illustration).



8.2 Sump drain plug location

1•10 Every 6000 miles or 6 months



8.7 Unscrewing the oil filter

3 Slacken the drain plug about half a turn. Position the draining container under the drain plug, then remove the plug completely. If possible, try to keep the plug pressed into the sump while unscrewing it by hand the last couple of turns. As the plug releases from the threads, move it away sharply so the stream of oil issuing from the sump runs into the container, not up your sleeve! Recover the sealing washer from the drain plug.

4 Allow some time for the old oil to drain, noting that it may be necessary to reposition the container as the oil flow slows to a trickle.

5 After all the oil has drained, wipe off the drain plug with a clean rag. Check the sealing washer for condition, and renew it if necessary. Clean the area around the drain plug opening, and refit the plug. Tighten the plug to the specified torque.

6 Move the container into position under the oil filter.

7 Using an oil filter removal tool if necessary, slacken the filter initially, then unscrew it by hand the rest of the way (see illustration). Empty the oil from the old filter into the container, and discard the filter.

8 Use a clean rag to remove all oil, dirt and sludge from the filter sealing area on the engine. Check the old filter to make sure that the rubber sealing ring hasn't stuck to the engine. If it has, carefully remove it.

9 Apply a light coating of clean engine oil to the sealing ring on the new filter, then screw it into position on the engine. Tighten the filter firmly by hand only - **do not** use any tools. Wipe clean the filter and sump drain plug.

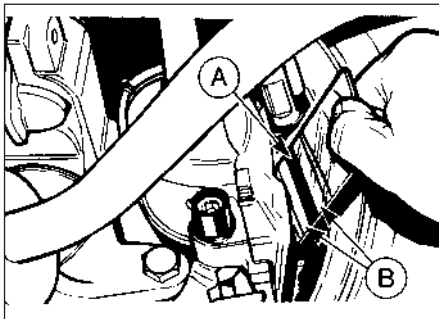

9.2 Using a mirror to inspect the disc pad friction material for wear
A Brake disc B Brake disc pads

10 Remove the old oil and all tools from under the car, then lower the car to the ground (if applicable).

11 Remove the oil filler cap and withdraw the dipstick. Fill the engine, using the correct grade and type of oil (see "*Lubricants and fluids*"). An oil can spout or funnel may help to reduce spillage. Pour in half the specified quantity of oil first, then wait a few minutes for the oil to fall to the sump. Continue adding oil a small quantity at a time until the level is up to the lower mark on the dipstick. Finally, bring the level up to the upper mark on the dipstick. Insert the dipstick, and refit the filler cap.

12 Start the engine and run it for a few minutes; check for leaks around the oil filter seal and the sump drain plug. Note that there may be a delay of a few seconds before the oil pressure warning light goes out when the engine is first started, as the oil circulates through the engine oil galleries and the new oil filter, before the pressure builds up.

13 Switch off the engine, and wait a few minutes for the oil to settle in the sump once more. With the new oil circulated and the filter completely full, recheck the level on the dipstick, and add more oil as necessary.

14 Dispose of the used engine oil safely, with reference to "*General repair procedures*" in the Reference section of this manual.

9 Front and rear brake pad/shoe check

1 Firmly apply the handbrake, then jack up the front and rear of the car and support it securely on axle stands (see "*Jacking and vehicle support*").

2 For a quick check, the front brake disc pads can be inspected without removing the front wheels by inserting a mirror between each caliper and roadwheel (see illustration). If any one pad is worn down to the minimum specified thickness, all four pads (on both front wheels) must be renewed.

3 It is necessary to remove the rear wheels in order to inspect the rear disc pads. The pads can be viewed through the top of the caliper after removing the blanking spring clip (see illustration). If any one pad is worn down to the minimum specified, all four pads (on both rear wheels) must be renewed.

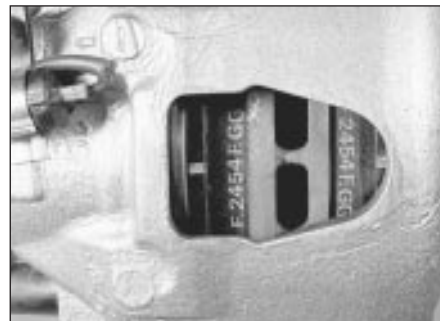

9.3 Disc pads viewed through caliper inspection hole (roadwheel removed)

4 For a comprehensive check, the brake disc pads should be removed and cleaned. The operation of the caliper can then also be checked, and the condition of the brake discs can be fully examined on both sides. Refer to Chapter 10 for further information.

5 On rear drum brake models, the brake shoe friction material can be inspected for wear without removing the roadwheels. Working beneath the vehicle, prise the plug from the brake backplate, and using an inspection lamp or torch, check that the friction material thickness is not less than the minimum given in the Specifications (see illustration). If any one of the shoes has worn below the specified limit, the shoes must be renewed as an axle set (4 shoes).

6 At the same interval, check the function of the brake fluid level warning light. Check the wheels, release the handbrake and switch on the ignition. Unscrew and raise the brake fluid reservoir cap whilst an assistant observes the warning light: it should come on as the level sensor is withdrawn from the fluid. Refit the cap.

7 On completion, refit the wheels and lower the car to the ground.

10 Fluid leak check

1 Visually inspect the engine joint faces, gaskets and seals for any signs of water or oil leaks. Pay particular attention to the areas around the rocker cover, cylinder head, oil filter and sump joint faces. Bear in mind that over a period of time some very slight seepage from these areas is to be expected but what you are really looking for is any indication of a serious leak. Should a leak be found, renew the offending gasket or oil seal by referring to the appropriate Chapter(s) in this manual.

2 Similarly, check the transmission for oil leaks, and investigate and rectify and problems found.

3 Check the security and condition of all the engine related pipes and hoses. Ensure that all cable-ties or securing clips are in place and in good condition. Clips which are broken or missing can lead to chafing of the hoses, pipes or wiring which could cause more serious problems in the future.



9.5 Brake shoe inspection hole plug (arrowed)

4 Carefully check the condition of all coolant, fuel, power steering and brake hoses. Renew any hose which is cracked, swollen or deteriorated. Cracks will show up better if the hose is squeezed. Pay close attention to the hose clips that secure the hoses to the system components. Hose clips can pinch and puncture hoses, resulting in leaks. If wire type hose clips are used, it may be a good idea to replace them with screw-type clips.

5 With the vehicle raised, inspect the fuel tank and filler neck for punctures, cracks and other damage. The connection between the filler neck and tank is especially critical. Sometimes a rubber filler neck or connecting hose will leak due to loose retaining clamps or deteriorated rubber.

6 Similarly, inspect all brake hoses and metal pipes. If any damage or deterioration is discovered, do not drive the vehicle until the necessary repair work has been carried out. Renew any damaged sections of hose or pipe.

7 Carefully check all rubber hoses and metal fuel lines leading away from the petrol tank. Check for loose connections, deteriorated hoses, crimped lines and other damage. Pay particular attention to the vent pipes and hoses which often loop up around the filler neck and can become blocked or crimped. Follow the lines to the front of the vehicle carefully inspecting them all the way. Renew damaged sections as necessary.

8 From within the engine compartment, check the security of all fuel hose attachments and pipe unions, and inspect the fuel hoses and vacuum hoses for kinks, chafing and deterioration.

9 Where applicable, check the condition of the oil cooler hoses and pipes.

10 Check the condition of all exposed wiring harnesses.

11 Seat belt check

1 Periodically check the belts for fraying or other damage. If evident, renew the belt.

2 If the belts become dirty, wipe them with a damp cloth using a little detergent only.

3 Check the tightness of the anchor bolts and if they are ever disconnected, make quite sure that the original sequence of fitting of washers, bushes and anchor plates is retained.

12 Exhaust system check

With the vehicle raised on a hoist or supported on axle stands, check the exhaust system for signs of leaks, corrosion or damage and check the rubber mountings for condition and security. Where damage or corrosion are evident, renew the system complete or in sections, as applicable, using the information given in Chapter 4.

13 Roadwheel security check

With the wheels on the ground, slacken each wheel nut by a quarter turn, then retighten it immediately to the specified torque.

14 Oil filler cap check

Remove and clean the oil filler cap of any sludge build-up using paraffin.

Inspect the vent hose for blockage or damage. A blocked hose can cause a build-up of crankcase pressure, which in turn can cause oil leaks.

15 Engine idle speed check



Caution: Refer to the precautions in Section 1, Chapter 4, Part A or B (as applicable), before proceeding.

Before carrying out any carburettor adjustments, ensure that the ignition timing and spark plug gaps are set as specified. To carry out the adjustments an accurate tachometer and an exhaust gas analyser (CO meter) will be required.

Ford VV carburettor

1 Ensure that the air cleaner is correctly fitted, and that all vacuum hoses and pipes are securely connected and free from restrictions, then run the engine until it is at normal operating temperature.

2 Stop the engine, and connect a tachometer and an exhaust gas analyser in accordance with the manufacturer's instructions.

3 Start the engine and run it at 3000 rpm for 30 seconds, ensuring that all electrical loads are switched off (headlamps, heater blower etc), then allow the engine to idle and check the idle speed and CO content. Note that the CO reading will initially rise, then fall and finally stabilise after between 5 and 25 seconds.

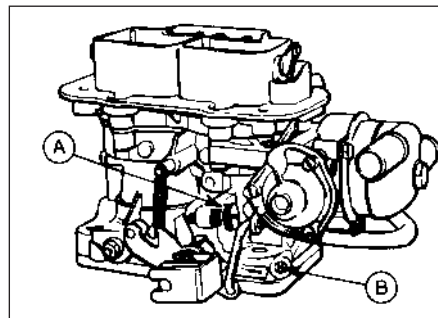

15.7a Weber 2V carburettor adjustment screw locations - 2.0 litre models up to 1985

A Idle speed screw B Idle mixture screw

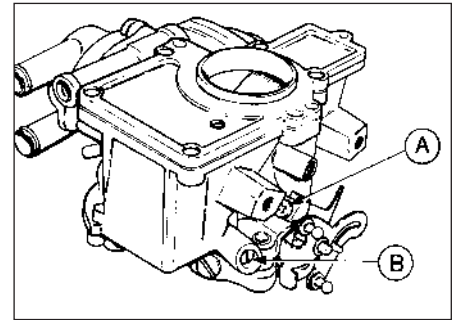

15.4 Ford VV carburettor adjustment screw locations

A Idle speed screw B Idle mixture screw

4 If necessary, adjust the idle speed screw to give the specified idle speed (see illustration).

5 Checking and adjustment should be completed within 30 seconds of the meter readings stabilising. If this has not been possible, repeat paragraphs 3 and 4, ignoring the reference to starting the engine.

Weber 2V carburettor

Models without stepper motor

6 Proceed as described for the Ford VV carburettor but note the following:

7 It is permissible to loosen the air cleaner securing screws to allow easier access to the carburettor adjustment screws but ensure that all vacuum hoses and pipes are securely connected. For adjustment screw location (see illustrations).

Models with stepper motor (ESC II system)

8 The idle speed is controlled by the ESC II module via the stepper motor. The only idle speed adjustment possible is provided by the "idle speed adjustment" wire, which can be earthed to raise the idle speed by 75 rpm. No other method of idle speed adjustment should be attempted. If the idle speed is incorrect, the problem should be referred to a Ford dealer, as the problem probably lies in the ESC II module for which special diagnostic equipment is required.

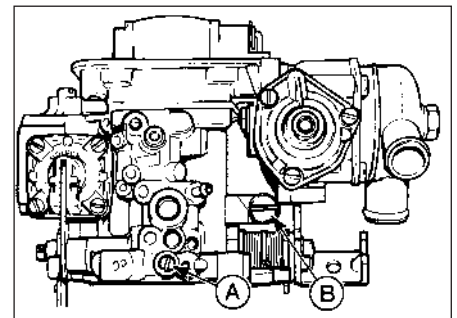

15.7b Weber 2V carburettor adjustment screw locations - 1.6 litre models

A Idle mixture screw B Idle speed screw

1•12 Every 6000 miles or 6 months

Pierburg 2V carburettor

9 Proceed as described for the Ford VV carburettor. For adjustment screw location (see illustration).

Weber 2V TLD carburettor

10 Proceed as described for the Ford VV carburettor, noting the following points:

11 Ensure that the vacuum pipe and the camshaft cover breather hose are securely connected to the air cleaner and are free from restrictions.

12 When warming-up the engine, run the engine until the cooling fan cuts in.

13 For adjustment screw location (see illustration).

Fuel injection

2.0 litre SOHC models

14 Idle speed is controlled by the EEC IV module and the only means of adjustment provided is by the yellow "idle speed adjustment" wire (Chapter 5, Section 17) which allows the idle speed to be raised by 75 rpm.

2.0 litre DOHC models

15 Idle speed is controlled by the EEC IV module, and manual adjustment is not possible.

16 The "base" idle speed can be adjusted, but only by a Ford dealer, using special equipment.

16 Mixture adjustment check



Caution: Refer to the precautions in Section 1, Chapter 4, Part A or B (as applicable), before proceeding.

Before carrying out any carburettor adjustments, ensure that the ignition timing and spark plug gaps are set as specified. To carry out the adjustments an accurate tachometer and an exhaust gas analyser (CO meter) will be required.

Ford VV carburettor

1 Ensure that the air cleaner is correctly fitted and that all vacuum hoses and pipes are securely connected and free from restrictions, then run the engine until it is at normal operating temperature.

2 Stop the engine, and connect a tachometer and an exhaust gas analyser in accordance with the manufacturer's instructions.

3 Start the engine and run it at 3000 rpm for 30 seconds, ensuring that all electrical loads are switched off (headlamps, heater blower etc), then allow the engine to idle and check the idle speed and CO content. Note that the CO reading will initially rise, then fall and finally stabilise after between 5 and 25 seconds.

4 If the reading noted in paragraph 3 is not as specified, proceed as follows.

5 Using a thin screwdriver, remove the tamperproof seal from the mixture screw.

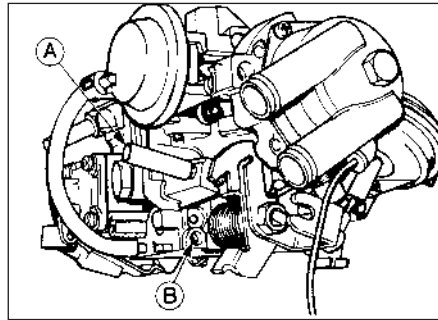

15.9 Pierburg 2V carburettor adjustment screw locations

A Idle speed screw B Idle mixture screw

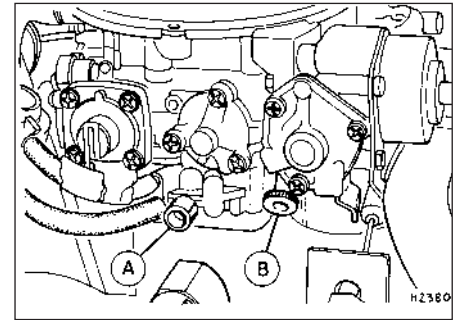

15.13 Weber 2V TLD carburettor adjustment screw locations

A Idle mixture screw B Idle speed screw

6 Run the engine at 3000 rpm for 30 seconds, then allow the engine to idle, and using a small screwdriver or a 4.0 mm Allen key, as applicable, adjust the mixture screw to give the specified CO content.

7 Checking and adjustment should be completed within 30 seconds of the meter readings stabilising. If this has not been possible, then repeat paragraph 6.

8 If necessary adjust the idle speed, then recheck the CO content.

9 On completion of the adjustments, stop the engine and disconnect the tachometer and exhaust gas analyser. Fit a new tamperproof seal to the mixture screw.

Weber 2V carburettor

Models without stepper motor

10 Proceed as described for the Ford VV carburettor but note the following:

11 To remove the mixture screw tamperproof seal, it will be necessary to drill the seal in order to prise it from the mixture screw housing. Alternatively a self-tapping screw can be used to draw out the seal. If the tamperproof seal is to be renewed, ensure that a blue-coloured replacement seal is fitted.

12 It is permissible to loosen the air cleaner securing screws to allow easier access to the carburettor adjustment screws, but ensure that all vacuum hoses and pipes are securely connected.

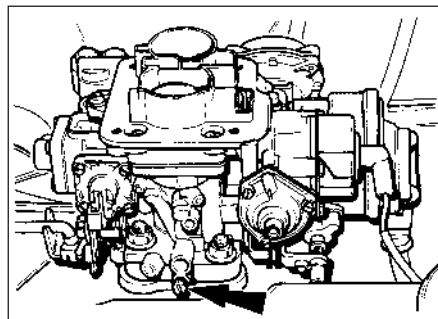

16.13 Weber 2V carburettor idle mixture adjustment screw location (arrowed) - 2.0 litre models from 1985

Models with stepper motor (ESC II system)

13 If necessary, the mixture can be adjusted as described for the Ford VV carburettor with reference to paragraphs 11 and 12 of this Section. Do not attempt to adjust the idle speed on completion of mixture adjustment. For adjustment screw location (see illustration).

Pierburg 2V carburettor

14 Proceed as described for the Ford VV carburettor.

Weber 2V TLD carburettor

15 Proceed as described for the Ford VV carburettor, noting the following points:

16 Ensure that the vacuum pipe and the camshaft cover breather hose are securely connected to the air cleaner and are free from restrictions.

17 When warming-up the engine, run the engine until the cooling fan cuts in.

18 If adjustment of the mixture (CO content) is required, the air cleaner must be removed for access to the adjustment screw, as follows.

19 Remove the air cleaner, and prise the tamperproof seal from the mixture screw.

20 Loosely refit the air cleaner, ensuring that the vacuum pipe and the camshaft cover breather hose are securely connected and free from restrictions (there is no need to secure the air cleaner in position).

21 On completion, fit a new tamperproof seal to the mixture screw (the service replacement plug is coloured blue), and refit the air cleaner assembly.

Fuel injection

2.0 litre SOHC models

22 The idle mixture can be checked and if necessary adjusted as follows:

23 Run the engine until it is at normal operating temperature.

24 Stop the engine and connect a tachometer and an exhaust gas analyser in accordance with the manufacturer's instructions.

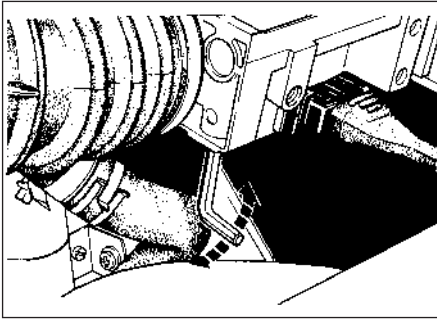

16.26 Adjusting the idle mixture - SOHC models

25 Start the engine and run it at 3000 rpm for 15 seconds, ensuring that all electrical loads (headlamps, heater blower etc) are switched off, then allow the engine to idle and check the CO content. Note that the CO reading will initially rise, then fall and finally stabilise.

26 If adjustment is necessary, remove the tamperproof cap from the base of the airflow meter, and turn the mixture screw using a suitable Allen key to give the specified CO content (see illustration).

27 Checking and adjustment should be completed within 30 seconds of the meter readings stabilising. If this has not been possible, run the engine at 3000 rpm, for 15 seconds, then allow the engine to idle. Re-check the CO content and carry out further adjustment if necessary.

28 On completion of adjustment, stop the engine and disconnect the tachometer and exhaust gas analyser. Fit a new tamperproof cap to the mixture screw.



16.34a Remove the cover from the mixture adjustment potentiometer . . .

2.0 litre DOHC models

29 On models with a catalytic converter, the mixture is controlled by the EEC IV module. No manual adjustment is possible.

30 On models without a catalytic converter, the idle mixture can be adjusted as follows:

31 Run the engine until it is at normal operating temperature.

32 Stop the engine, and connect a tachometer and an exhaust gas analyser in accordance with the equipment manufacturer's instructions.

33 Start the engine and run it at 3000 rpm for 15 seconds, ensuring that all electrical loads (headlamps, heater blower, etc) are switched off. Allow the engine to idle, and check the CO content. Note that the reading will initially rise, then fall and finally stabilise.

34 If adjustment is necessary, remove the cover from the mixture adjustment potentiometer (located at the rear right-hand



16.34b . . . to enable mixture adjustment - DOHC models

side of the engine compartment, behind the MAP sensor), and turn the screw to give the specified CO content (see illustrations).

35 If adjustment does not produce a change in reading, the potentiometer may be at the extreme of its adjustment range. To centralise the potentiometer, turn the adjustment screw 20 turns clockwise followed by 10 turns anti-clockwise, then repeat the adjustment procedure.

36 Checking and adjustment should be completed within 30 seconds of the meter readings stabilising. If this has not been possible, run the engine at 3000 rpm for 15 seconds, then allow the engine to idle. Re-check the CO content, and carry out further adjustments if necessary.

37 On completion of adjustment, stop the engine, and disconnect the tachometer and the exhaust gas analyser. Refit the cover to the adjustment screw.

Every 12 000 miles (20 000 km) or 12 months

17 Automatic transmission fluid level check



1 Fluid level should be checked with the transmission at operating temperature (after a run) and with the vehicle parked on level ground.

2 Open and prop the bonnet. With the engine idling and the handbrake and footbrake applied, move the gear selector through all positions three times, finishing up in position "P".

3 Wait one minute. With the engine still idling, withdraw the transmission dipstick (see illustration). Wipe the dipstick with a clean lint-free rag, re-insert it fully and withdraw it again. Read the fluid level at the end of the dipstick: it should be between the two notches.

4 If topping-up is necessary, do so via the dipstick tube, using clean transmission fluid of the specified type (see illustration). Do not overfill.

5 Stop the engine, refit the dipstick and close the bonnet.

6 Note that if the fluid level was below the minimum mark when checked or is in constant need of topping-up, check around the transmission for any signs of excessive fluid leaks. If present, leaks must be rectified without delay.

7 If the colour of the fluid is dark brown or black this denotes the sign of a worn brake band or transmission clutches, in which case have your Ford dealer check the transmission at the earliest opportunity.

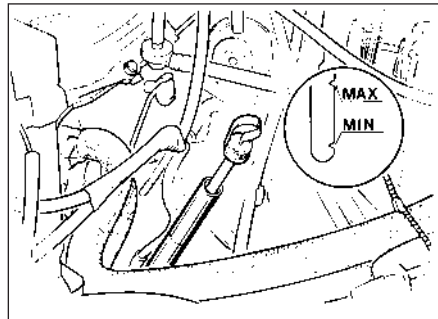

17.3 Automatic transmission dipstick location and markings

18 Manual gearbox oil level check



1 Place the vehicle over a pit, or raise and support it at front and rear. The vehicle must be level for an accurate check.

2 If the gearbox is hot after a run, allow it to cool for a few minutes. This is necessary because the oil can foam when hot and give a false level reading.



17.4 Topping-up the transmission fluid

1•14 Every 12 000 miles or 12 months

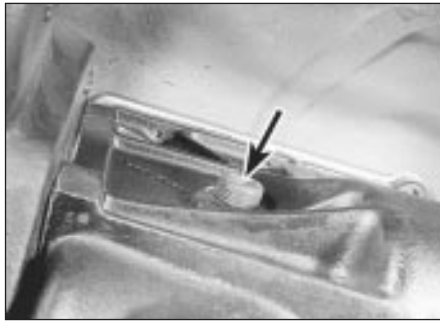

18.3 Gearbox filler/level plug location (arrowed) - N type gearbox

3 Wipe clean around the filler/level plug. Unscrew the plug and remove it (see illustration).

4 Using a suitably marked piece of bent wire as a dipstick, check that the oil level is as shown in the table at the top of this page, according to gearbox type.

5 Top-up the level if necessary, using clean oil of the specified type. Do not overfill, as this can lead to leakage and difficult gear changing. Allow excess oil to drip out of the filler/level hole if necessary. Refit and tighten the filler/level plug on completion.

6 The frequent need for topping-up can only be due to leaks, which should be rectified. The most likely sources of leaks are the rear extension housing and input shaft oil seals.

7 No periodic oil changing is specified, and no drain plug is fitted.

19 Hinge and lock check and lubrication

1 Work around the vehicle, and lubricate the bonnet, door and tailgate hinges with a light machine oil.

2 Lightly lubricate the bonnet release mechanism and exposed sections of inner cable with a smear of grease.

3 Check the security and operation of all hinges, latches and locks, adjusting them where required. Where applicable, check the operation of the central locking system.

4 Check the condition and operation of the tailgate struts, renewing them if either is leaking or is no longer able to support the tailgate securely when raised.

20 Spark plug renewal

1 The correct functioning of the spark plugs is vital for the correct running and efficiency of the engine. It is essential that the plugs fitted are appropriate for the engine.

2 Make sure that the ignition is switched off before inspecting the HT leads to see if they carry their cylinder numbers. Note that the position of No 1 cylinder HT lead in the distributor cap is marked with either a pip, or a number "1".

Gearbox type	Oil level
All four-speed gearboxes	0 to 5.0 mm (0 to 0.2 in) below lower edge of filler/level hole
All five-speed gearboxes up to April 1984 (build code E6) except those subsequently fitted with a modified extension housing	Level with bottom edge of filler/level hole
All five-speed gearboxes from May 1984 (build code EC) to end of April 1985 (build code FP) and all vehicles built up to April 1984 (build code E6) subsequently fitted with a modified gearbox extension housing	20.0 to 25.0 mm (0.79 to 0.99 in) below lower edge of filler/level hole
All five-speed gearboxes from May 1985	0 to 5.0 mm (0 to 0.2 in) below lower edge of filler/level hole

Note: The vehicle build code appears as the twelfth and thirteenth characters of the VIN number on the plate in the engine compartment.



Number each HT lead using sticky tape or paint before removal so as to avoid confusion when refitting.

3 Where necessary, for improved access remove the air cleaner and/or the inlet hose.

4 Disconnect the leads from the plugs by pulling on the connectors, not the leads.

5 On 2.0 litre DOHC carburettor models, the location of the spark plugs and the close proximity of the carburettor makes spark plug access difficult, particularly when removing the plugs from cylinders 2 and 3. It is suggested that a 3/8 inch ratchet drive spark plug socket with rubber insert and long extension bar is used, possibly in conjunction with a universal joint adapter. It is also advisable to disconnect No 3 cylinder HT lead from the distributor first, to allow some slack for disconnection at the spark plug.

6 Clean the area around each spark plug using a small brush, then using a plug spanner (preferably with a rubber insert), unscrew and remove the plugs (see illustration). Cover the spark plug holes with a clean rag to prevent the ingress of any foreign matter.

7 Before fitting new spark plugs, check that the threaded connector sleeves are tight. As the plugs incorporate taper seats, make sure that the threads and seats are clean.



20.6 Removing a spark plug - CVH engine

8 On DOHC models before refitting the spark plugs, coat their threads with suitable anti-seize compound, taking care not to contaminate the electrodes.

9 Screw in the spark plugs by hand, then tighten them to the specified torque. Do not exceed the torque figure.

10 Push the HT leads firmly onto the spark plugs, and where applicable refit the air cleaner and/or inlet hose.

21 Auxiliary drivebelt check

1 Refer to the Specifications at the beginning of this Chapter and check the tension of each drivebelt at the point stated. Check the full length of each drivebelt for cracks and deterioration. It will be necessary to turn the engine in order to check that portion of the drivebelt in contact with the pulleys. Renew or tension each belt as necessary as follows, according to model type:

SOHC models

2 Note that two drivebelts are fitted to models equipped with power steering and both should be renewed if either one is unserviceable. Where fitted, the air conditioning compressor is driven by a separate belt.

3 Disconnect the battery negative lead.

4 Where applicable, remove the air conditioning compressor drivebelt.

5 Loosen the alternator mounting and adjustment nuts and bolts, and pivot the alternator towards the cylinder block.

6 Slip the drivebelt(s) from the alternator, water pump, crankshaft and (where applicable) the power steering pump pulleys.

7 Fit the new drivebelt(s) over the pulleys, then lever the alternator away from the cylinder block until the specified belt tension is achieved. Lever the alternator using a wooden or plastic lever at the pulley end to prevent damage and straining the brackets. It is helpful to partially tighten the adjustment link bolt before tensioning the drivebelt(s).

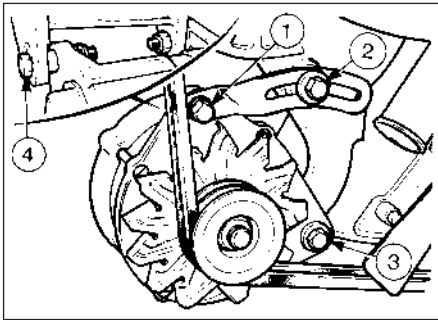

21.8 Alternator mounting tightening sequence - SOHC engines

8 Tighten the alternator mounting and adjustment nuts and bolts in the order shown (see illustration).

9 Where applicable, refit and tension the air conditioning compressor drivebelt.

10 Reconnect the battery negative lead.

11 Drivebelt tension should be rechecked and if necessary adjusted after the engine has been run for a minimum of ten minutes.

DOHC models

12 Three different types of drivebelt arrangement are used, depending on model (see illustrations). On models without power

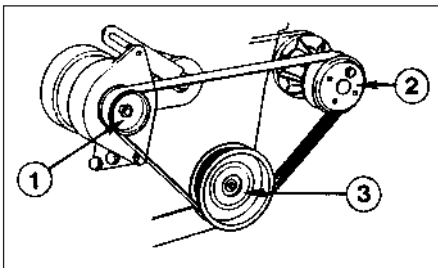

21.12a Coolant pump/alternator drivebelt arrangement - 2.0 litre DOHC engine without power steering

- 1 Alternator
- 2 Coolant pump
- 3 Crankshaft pulley

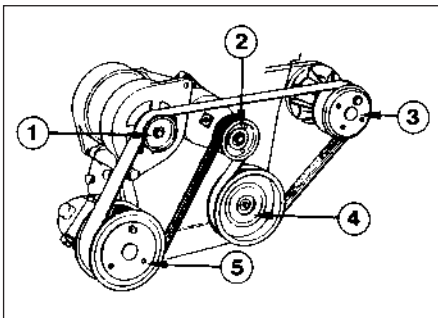

21.12b Coolant pump/alternator drivebelt arrangement - 2.0 litre DOHC engine with power steering

- 1 Alternator
- 2 Automatic belt tensioner
- 3 Coolant pump
- 4 Crankshaft pulley
- 5 Power steering pump

steering, the drivebelt is tensioned by moving the alternator. On models with power steering, the power steering pump is also driven by the coolant pump/alternator drivebelt and an automatic belt tensioner is fitted (see illustration). On models with air conditioning, the drivebelt drives the alternator, coolant pump, power steering pump and air conditioning compressor, and an automatic belt tensioner is fitted.

13 On models without power steering, loosen the alternator mounting and adjustment bolts, and pivot the alternator towards the cylinder block. Slip the drivebelt from the pulleys.

14 On models with power steering, the automatic tensioner can be released using a 17 mm socket and a wrench on the boss in the centre of the pulley. Lever the tensioner assembly clockwise, slide the belt from the pulleys, then slowly release the tensioner.

15 To fit a new belt on models without power steering, slide the belt over the pulleys, then lever the alternator away from the cylinder block until the correct belt tension is achieved. Lever the alternator using a plastic or wooden lever at the pulley end to prevent damage. It is helpful to partially tighten the adjustment link bolt before tensioning the drivebelt. When the correct tension is achieved, tighten all the bolts.

16 To fit a new belt on models with power steering, lever the tensioner clockwise as during removal, then slide the belt over the pulleys, and slowly release the tensioner.

22 Battery terminal check



Caution: Before carrying out any work on the vehicle battery, read through the precautions given in "Safety first!" at the beginning of this manual.

1 The battery fitted as original equipment is "maintenance-free", and requires no

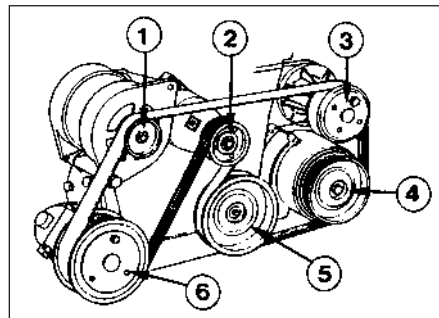

21.12c Coolant pump/alternator drivebelt arrangement - 2.0 litre DOHC engine with power steering and air conditioning

- 1 Alternator
- 2 Automatic belt tensioner
- 3 Coolant pump
- 4 Air conditioning compressor
- 5 Power steering pump
- 6 Crankshaft pulley

maintenance apart from having the case kept clean, and the terminals clean and tight.

2 To clean the battery terminals disconnect them, after having first removed the cover (later models) - negative earth first. Use a wire brush or abrasive paper to clean the terminals. Bad corrosion should be treated with a solution of bicarbonate of soda, applied with an old toothbrush. Do not let this solution get inside the battery.

3 Coat the battery terminals with petroleum jelly or a proprietary anti-corrosive compound before reconnecting them. Reconnect and tighten the positive (live) lead first, followed by the negative (earth) lead. Do not overtighten.

4 Keep the top of the battery clean and dry. Inspect the battery tray for corrosion, and make good as necessary.

23 Engine valve clearance check

HAYNES HINT It will be easier to turn the engine by hand if the spark plugs are removed but take care not to allow dirt to enter the spark plug holes.

SOHC engines

1 The valve clearances must be checked with the engine cold. On carburettor models remove the air cleaner.

2 Disconnect the HT leads from the spark plugs and release them from the clips on the camshaft cover.

3 On fuel injection models, unbolt and remove the bracing strut securing the inlet manifold to the right-hand side of the cylinder head.

4 Where applicable, unclip any hoses and wires from the camshaft cover, then unscrew the securing bolts and remove the camshaft cover and gaskets. Take care not to lose the spacer plates which fit under the bolt heads, where applicable.

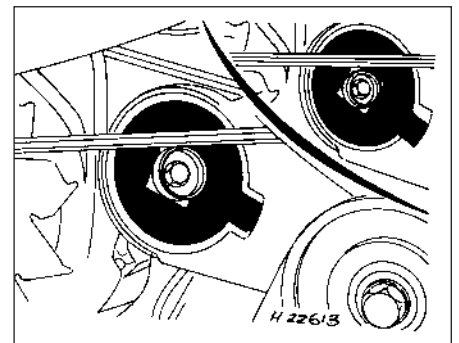

21.12d Alternator/coolant pump drivebelt tensioner indicator position - 2.0 litre DOHC engine

Inset shows tensioner at maximum adjustment

1•16 Every 12 000 miles or 12 months

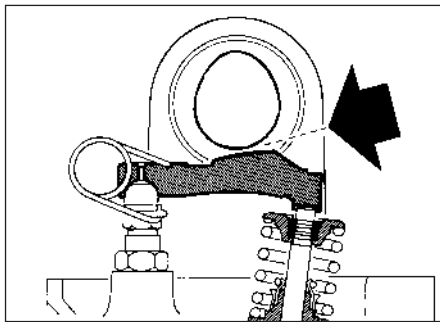

23.6 Cam lobe correctly positioned for checking valve clearance. Insert feeler gauge as shown by arrow

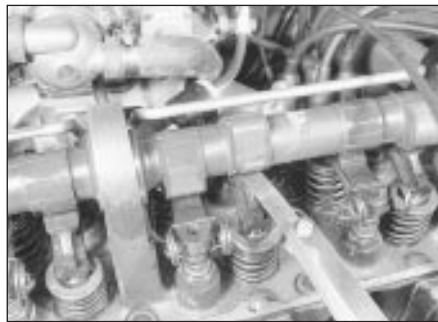

23.7a Using a feeler gauge to check a valve clearance



23.7b Adjusting a valve clearance

5 Numbering from the front (camshaft sprocket) end of the engine, the exhaust valves are 1, 3, 5 and 7, and the inlet valves are 2, 4, 6 and 8.

6 Turn the engine clockwise using a suitable socket on the crankshaft pulley bolt, until the exhaust valve of No 1 cylinder (valve No 1) is fully closed; ie the cam lobe is pointing vertically upwards (see illustration).

7 Insert a feeler blade of the correct thickness (see Specifications) between the cam follower and the heel of the No 1 valve cam lobe. The feeler blade should be a firm sliding fit. If not, loosen the locknut and adjust the ball-pin position accordingly by turning the adjuster

nut, then tighten the locknut (see illustrations). Allowance must be made for tightening the locknut, as this tends to decrease the valve clearance. Recheck the adjustment after tightening the locknut.

8 Repeat the procedure given in paragraphs 6 and 7 for the remaining valves. With the carburettor/inlet manifold fitted, some difficulty may be experienced when adjusting the exhaust valve clearances, and a suitable open-ended spanner bent to 90° will be found helpful.

9 Check the condition of the camshaft cover gasket, and renew if necessary. Fit the gasket to the camshaft cover ensuring that the locating tabs and dovetails are correctly located (see illustration), then refit the camshaft cover and tighten the securing bolts in the order shown (see illustration), ensuring that the spacer plates are in position under the bolt heads, where applicable.

10 On fuel injection models, refit the inlet manifold bracing strut.

11 Where applicable refit the spark plugs. Reconnect the HT leads and locate them in the clips on the camshaft cover.

12 Where applicable, refit any wires and hoses to the clips on the camshaft cover and on carburettor models, refit the air cleaner.

25 Radiator matrix and air conditioner condenser clean

Gain access to the radiator matrix by removing the surrounding body panels, fan shrouds, etc. Clean dirt and debris from the matrix using an air jet or water and a soft brush. Be careful not to damage the fins or cut your fingers.

Remove the protecting grille and clean any leaves, insects etc. from the air conditioner condenser coil and fins. Be very careful not to damage the condenser fins: use a soft brush, or a compressed air jet, along (not across) the fins.

26 Air conditioner reffridgerant charge check

1 If applicable, remove the radiator grille being careful not to damage the condenser fins.

2 Check the refrigerant charge as follows. The engine should be cold and the ambient temperature should be between 64° and 77°F (18° and 25°C).

3 Start the engine and allow it to idle. Observe the refrigerant sight glass (see illustration) and have an assistant switch on the air conditioning to fan speed III. A few bubbles should be seen in the sight glass as the system starts up, but all bubbles should disappear within 10 seconds. Persistent bubbles, or no bubbles at all, mean that the refrigerant charge is low. Switch off the



23.9a Camshaft cover gasket dovetails

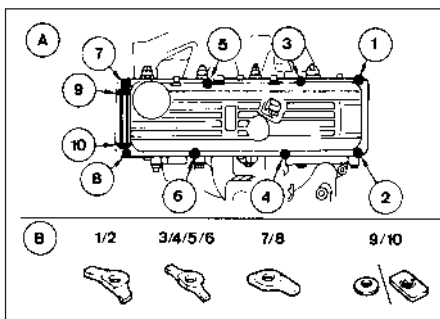

23.9b Camshaft cover bolts (A) and spacer plates (B)

Tighten bolts in following stages:
 Stage 1 Bolts 1 to 6
 Stage 2 Bolts 7 and 8
 Stage 3 Bolts 9 and 10
 Stage 4 Bolts 7 and 8 (again)

DOHC and CVH engines

13 These engines are fitted with hydraulic cam followers therefore no adjustment is necessary.

24 Handbrake check

Chock the front roadwheels and jack the rear wheels clear of the ground, supporting the vehicle with axlestands.

Check that with the handbrake released, the rear wheels are free to rotate and no brake "bind" is evident. The handbrake lever travel should be between two and four clicks of the ratchet. If brake "bind" or excessive lever travel is evident, check the handbrake cable routing and check the self-adjuster mechanism for wear or damage. Refer to Chapter 10 for full service information.

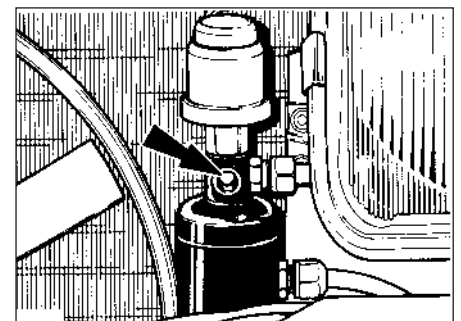

26.3 Air conditioning system refrigerant sight glass (arrowed)

system immediately if the charge is low and do not use it again until it has been recharged.

4 Inspect the refrigerant pipes, hoses and unions for security and good condition. Refit the radiator grille.

5 The air conditioning system will lose a proportion of its charge through normal seepage typically up to 100 g (4 oz) per year - so it is as well to regard periodic recharging as a maintenance operation.

27 Final drive oil level check

- 1 Check the final drive oil level as follows.
- 2 Position the vehicle over a pit, or raise it at front and rear on ramps or axle stands. The vehicle must be level.
- 3 Wipe clean around the final drive filler/level plug (see illustrations) and unscrew the plug. Using a piece of bent wire as a dipstick, check that the oil is no more than 10 mm (0.4 in) below the plug hole.
- 4 If topping-up is necessary, use clean gear oil of the specified type. Do not overfill. Frequent need for topping-up can only be due to leaks, which should be rectified.
- 5 When the level is correct, refit the filler/level plug and tighten it to the specified torque loading.
- 6 There is no requirement for periodic oil changing, and no drain plug is provided.

28 Automatic transmission selector linkage lubrication

Lubricate the transmission selector and kickdown linkages with engine oil or aerosol lubricant.

29 Steering and suspension security check

- 1 Check the shock absorbers by bouncing the vehicle up and down at each corner in turn. When released, it should come to rest within one complete oscillation. Continued movement, or squeaking and groaning noises from the shock absorber suggests that renewal is required.
- 2 Raise and support the vehicle. Examine all steering and suspension components for wear and damage. Pay particular attention to dust covers and gaiters, which if renewed promptly when damaged can save further damage to the component protected.
- 3 At the same intervals, check the front suspension lower arm balljoints for wear by levering up the arms (see illustration). Balljoint free movement must not exceed 0.5 mm (0.02 in). The track rod end balljoints can be checked in a similar manner, or by observing them whilst an assistant rocks the steering wheel back and forth. If the lower arm balljoint is worn, the complete lower arm must be renewed.

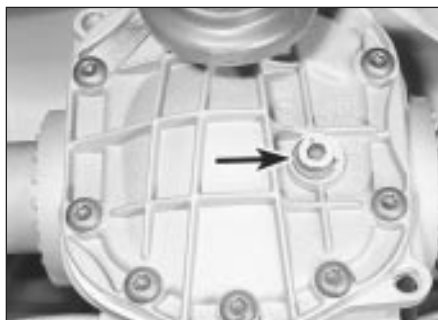

27.3a Final drive unit filler plug location (arrowed) -
Saloon, Hatchback and Estate models

4 Wheel bearings can be checked for wear by spinning the relevant roadwheel. Any roughness or excessive noise indicates worn bearings, which must be renewed, as no adjustment is possible. It is unlikely that any wear will be evident unless the vehicle has covered a very high mileage. It should be noted that it is normal for the bearings to exhibit slight endfloat, which is perceptible as wheel rock at the wheel rim.

30 Driveshaft check

- 1 Position the vehicle over a pit, or raise it at front and rear on ramps or axle stands (see "Jacking and vehicle support").
- 2 Examine the driveshaft joint rubber gaiters. Flex the gaiters by hand and inspect the folds and clips. Damaged or leaking gaiters must be renewed without delay to avoid damage occurring to the joint itself.
- 3 Check the tightness of the final drive mounting bolts and the driveshaft flange screws.

31 Underbody inspection

1 Except on vehicles with a wax-based underbody protective coating, have the whole of the underframe of the vehicle steam-cleaned, engine compartment included, so that a thorough inspection can be carried out to see what minor repairs and renovations are necessary.

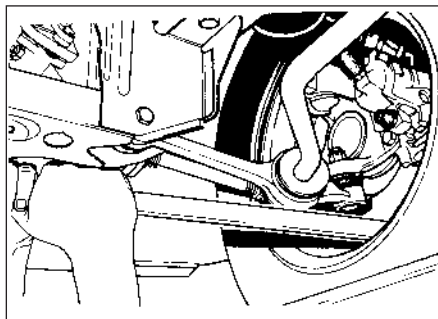

29.3 Levering up lower arm to check balljoint for wear



27.3b Rear axle filler plug location -
P100 models

- 2 Steam-cleaning is available at many garages and is necessary for the removal of the accumulation of oily grime which sometimes is allowed to become thick in certain areas. If steam-cleaning facilities are not available, there are some excellent grease solvents available which can be brush-applied; the dirt can then be simply hosed off.
- 3 After cleaning, position the vehicle over a pit, or raise it at front and rear on ramps or axle stands (see "Jacking and vehicle support").
- 4 Using a strong light, work around the underside of the vehicle, inspecting it for corrosion or damage. If either is found, refer to Chapter 12 for details of repair.

32 Brake pipe and hose check

Periodically inspect the rigid brake pipes for rust and other damage, and the flexible hoses for cracks, splits or "ballooning". Have an assistant depress the brake pedal (ignition on) and inspect the hose and pipe unions for leaks. Renew any defective item without delay.

33 Idle speed linkage clean

On carburettor models which incorporate a stepper motor (ie. Weber 2V from 1985), good electrical contact between the motor plunger and the adjusting screw is essential to maintain a regular idle speed.

Clean the plunger and adjusting screw contact faces with abrasive paper followed by switch cleaning fluid. Switch cleaning fluid is available from electronic component shops.

34 Road test

Instruments and electrical equipment

- 1 Check the operation of all instruments and electrical equipment.
- 2 Make sure that all instruments read correctly, and switch on all electrical equipment in turn to check that it functions properly.

1•18 Every 24 000 miles or 2 years



35.1 Loosening the crankcase ventilation hose clip - CVH models

Steering and suspension

- 3 Check for any abnormalities in the steering, suspension, handling or road "feel".
- 4 Drive the vehicle, and check that there are no unusual vibrations or noises.
- 5 Check that the steering feels positive, with no excessive "sloppiness", or roughness, and check for any suspension noises when cornering, or when driving over bumps.

Drivetrain

- 6 Check the performance of the engine, clutch, transmission and driveshafts.
- 7 Listen for any unusual noises from the engine, clutch and transmission.
- 8 Make sure that the engine runs smoothly when idling, and that there is no hesitation when accelerating.

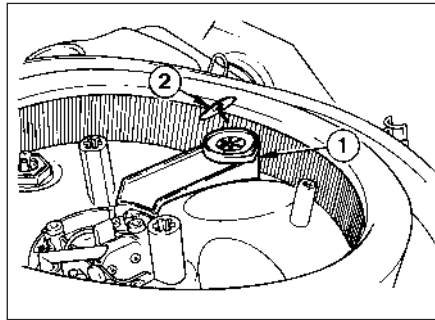

35.3 Oil separator (1) and mushroom valve (2) locations in air cleaner - CVH models

9 Where applicable, check that the clutch action is smooth and progressive, that the drive is taken up smoothly, and that the pedal travel is not excessive. Also listen for any noises when the clutch pedal is depressed.

10 Check that all gears can be engaged smoothly, without noise, and that the gear lever action is not abnormally vague or "notchy".

Check the operation and performance of the braking system

- 11 Make sure that the vehicle does not pull to one side when braking, and that the wheels do not lock prematurely when braking hard.
- 12 Check that there is no vibration through the steering when braking.
- 13 Check that the handbrake operates correctly, without excessive movement of the

lever, and that it holds the vehicle stationary on a slope.

14 Test the operation of the brake servo unit as follows. With the engine off, depress the footbrake four or five times to exhaust the vacuum. Start the engine, holding the brake pedal depressed. As the engine starts, there should be a noticeable "give" in the brake pedal as vacuum builds up. Allow the engine to run for at least two minutes, and then switch it off. If the brake pedal is depressed now, it should be possible to detect a hiss from the servo as the pedal is depressed. After about four or five applications, no further hissing should be heard, and the pedal should feel considerably firmer.

35 Crankcase ventilation system check

1 Inspect the crankcase ventilation system for blockage or damage. A blocked hose can cause a build-up of crankcase pressure, which in turn can cause oil leaks (see illustration).

2 On carburettor model SOHC engines, clean the oil filler cap with paraffin and check that the vent valve is not blocked by pulling it from the oil separator and loosening the hose clip (Section 42).

3 On CVH engines, check that the oil separator and mushroom valve are not blocked, and clean if necessary (see illustration).

Every 24 000 miles (40 000 km) or 2 years

36 Air cleaner inlet air temperature control check

SOHC and DOHC carburettor models

1 A vacuum pump will be required to test the control components.

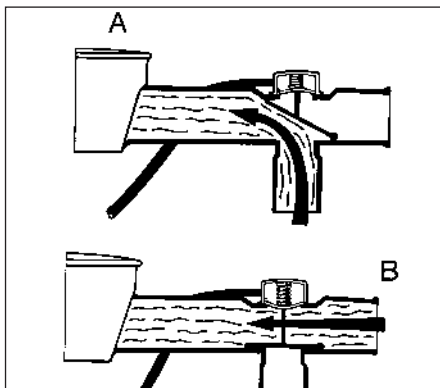

36.2 Air cleaner flap valve operation - OHC models

- A Flap fully open to admit hot air
- B Flap fully closed to admit cold air

2 To check the operation of the air temperature control, the engine must be cold. First observe the position of the flap valve which should be fully closed prior to starting the engine (see illustration). The position of the flap can be observed by disconnecting the cold air inlet hose from the air cleaner spout and looking into the spout.

3 Start the engine and allow it to idle. Check that the flap is now fully open to admit hot air from the exhaust manifold shroud. If the flap does not fully open, stop the engine and check the vacuum diaphragm unit and heat sensor as follows (see illustrations).



36.3a Air cleaner vacuum diaphragm unit - OHC models

4 Working under the base of the air cleaner body, disconnect the diaphragm unit-to-heat sensor vacuum pipe at the sensor end, and connect a vacuum pump to the diaphragm unit. Apply a vacuum of 100.0 mm (4.0 in) of mercury.

5 If the flap opens, then the heat sensor is faulty and should be renewed. If the flap remains closed, then the diaphragm unit is faulty, and a new air cleaner body will have to be obtained, as the diaphragm unit is not available separately.

6 On completion of the checks, disconnect the vacuum pump, and reconnect the vacuum pipe and cold air inlet hose.



36.3b Air cleaner heat sensor viewed from inside air cleaner - OHC models

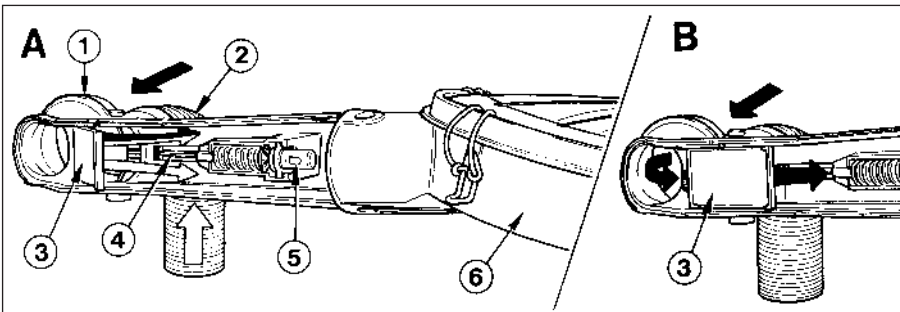

36.7 Air cleaner flap valve operation - CVH models

A Flap fully open to admit hot air
 B Flap fully closed to admit cold air
 1 Air inlet spout
 2 Hot air inlet hose

3 Flap valve
 4 Link arm
 5 Waxstat
 6 Air cleaner body

37 Pulse air filter element renewal (1.6 litre CVH)

- 1 The pulse-air filter is located at the front left-hand side of the engine compartment.
- 2 To renew the element, simply unclip the filter cover, then lift out the metal gauze, and withdraw the filter element (see illustration).
- 3 Refitting is a reversal of removal. Ensure that the holes in the gauze and the filter element are positioned on the engine side of the filter housing.

38 Air cleaner element renewal

Carburettor models

- 1 Remove the screws from the top of the air cleaner cover (see illustration).
- 2 Where applicable release the spring clips around the edge of the cover, then lift or prise off the cover (see illustration).
- 3 Lift out the air cleaner element. Wipe the inside of the air cleaner body clean, taking care not to allow dirt to enter the carburettor throat. Also clean the inside of the cover.
- 4 Place a new element in position, then refit the air cleaner cover.

Fuel-injection models

All models except 2.0 litre DOHC

- 5 Disconnect the battery negative lead.
- 6 Depress the locking clip on the airflow meter wiring plug and disconnect the plug. Pull on the plug, not the wiring (see illustration).
- 7 Loosen the securing clip and disconnect the air inlet hose from the airflow meter.
- 8 Release the four securing clips and lift off the air cleaner lid with the airflow meter.
- 9 Lift out the old air cleaner element (see illustration), then wipe the inside of the air cleaner casing and lid clean.
- 10 Fit the new element with the sealing lip uppermost.
- 11 Refit the air cleaner lid and secure with the four clips.
- 12 Reconnect the air inlet hose to the airflow meter, ensuring that the securing clip is correctly aligned (see illustration). Reconnect the wiring plug.



37.2 Withdrawing the pulse-air filter element and gauze - 1.6 litre CVH models



38.1 Remove the air cleaner cover screws . . .



38.2 . . . release the spring clips, and lift off the cover for access to the element



38.6 Disconnecting the airflow meter wiring plug



38.9 Unclip the lid and remove the air cleaner element

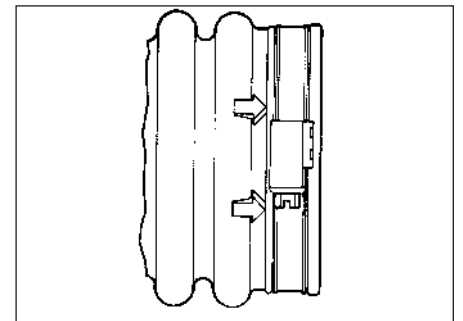

38.12 Air intake hose clip correctly aligned



38.17 Air intake tube securing nut (arrowed)

13 Reconnect the battery negative lead.

2.0 litre DOHC models

14 Disconnect the battery negative lead.

15 Disconnect the wiring plug from the idle speed control valve at the front of the plenum chamber.

16 Loosen the clamp, and detach the air inlet hose from the air inlet tubing.

17 Unscrew the securing nut, and release the air inlet tube from the bracket on the engine compartment front panel (see illustration).

18 Release the air cleaner lid securing clips, then lift away the air inlet tube, plenum chamber and air cleaner lid as an assembly, disconnecting the breather hose from the air inlet tube.

19 Lift out the air cleaner element (see illustration), then wipe the inside of the air cleaner lid and casing clean.

20 Fit the new element with the sealing lip uppermost.

21 Further refitting is a reversal of removal.

39 Ignition system component check

1 Before disturbing any part of the ignition system, disconnect the battery negative lead.

2 Identify and clearly mark all HT leads before disconnecting them from the spark plugs.

3 Refer to the appropriate Section in Chapter 5 and, where applicable, remove the distributor cap and rotor arm.

4 Clean the HT leads and distributor cap with a dry cloth. Scrape any corrosion or other

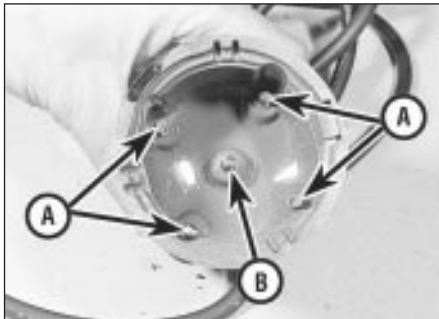

39.6 Bosch distributor cap showing HT segments (A) and carbon brush (B)



38.19 Lifting out the air cleaner element

deposits from the connectors and terminals. Also clean the coil tower.

5 Renew the HT leads if they are cracked, burnt or otherwise damaged. If a multi-meter is available, measure the resistance of the leads. The desired value is given in the Specifications of Chapter 5.

6 Renew the distributor cap if it is cracked or badly burnt inside, or if there is evidence of "tracking" (black lines marking the path of HT leakage). If there is a carbon brush at the centre of the cap, make sure that it moves freely, and is not excessively worn (see illustration).

7 Clean the metal track of the rotor arm with fine abrasive paper. Renew the arm if it is cracked or badly burnt.

8 Refit the rotor arm and distributor cap.

9 Reconnect the HT leads to the spark plugs and coil.

10 Reconnect the battery and run the engine.

40 Automatic transmission brake band adjustment

Note: A brake band torque wrench - Ford tool No 17-005, or a conventional torque wrench and a splined socket of suitable size to fit the square section head of the adjuster screw(s) will be required for this operation.

1 For improved access, apply the handbrake, then jack up the front of the vehicle and support on axle stands (see "Jacking and vehicle support").

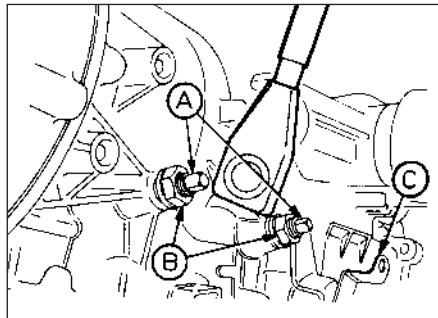

40.2 Brake band adjustment - A4LD type transmission

A Adjuster screws C Kickdown lever
B Locknuts

2 The brake band adjuster screw(s) is/are situated on the left-hand side of the transmission housing, forward of the kickdown lever. Note that the C3 type transmission has a single adjuster screw for adjustment of the front brake band, whereas the A4LD type transmission has two adjuster screws for adjustment of the front and intermediate brake bands (see illustration).

3 Disconnect the kickdown cable from the kickdown lever on the transmission housing.

4 Loosen the locknut on the front brake band adjuster screw, and back off the adjuster screw several turns.

5 Using the Ford special tool or a suitable equivalent, tighten the adjuster screw to the specified torque, then back off the screw two complete turns, and tighten the locknut. Ensure that the adjuster screw does not turn as the locknut is tightened.

6 Repeat the procedure given in paragraphs 4 and 5 for the remaining adjuster screw on A4LD type transmissions, but on all models where the part number on the transmission identification tag starts with "88" (see illustration) and additionally on all 1.8 CVH engine models, the adjuster screw should be backed off two and a half turns after tightening to the specified torque. On all other models, the adjuster screw should be backed off two turns.

7 Reconnect the kickdown cable, and lower the vehicle to the ground on completion.

41 Fuel filter renewal



Caution: Refer to the precautions in Chapter 4, Part B, Section 1 before proceeding.

2.0 litre SOHC fuel injection models

1 The fuel filter is located on the left-hand side of the engine compartment (see illustration).

2 Disconnect the battery negative lead.

3 Position a suitable container beneath the filter, then slowly loosen the fuel inlet union to relieve the pressure in the fuel lines.

4 Disconnect the fuel inlet and outlet unions. Be prepared for petrol spillage. If necessary, identify the fuel line unions for use when refitting.

5 Loosen the filter clamp screw, and withdraw the filter from the clamp. Drain the petrol from the filter into the container. Dispose of the filter carefully.

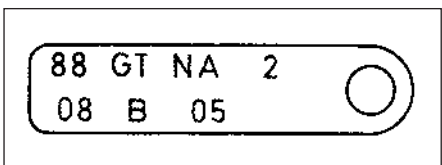

40.6 Transmission identification tag with part number starting with "88"