

H08B

HANIX
Mini Excavators



Parts Catalogue

Japanese Craftsmanship

How to Use Parts Catalogue

1. This parts catalogue covers all components for excavator model H08B when ordering parts refer to the under mentioned items.
2. To read the parts catalogue:
 - a) Parts marked with * are composed of assembly parts, ◇ shows component parts.
 - b) Originally the parts are shown in essential numbers for unit machine in the column, however, the component parts are meant for unit.
 - c) Parts marked with ○ in the parts No. column are not supplied by single piece but are supplied in components are assembly.
 - d) Marks appearing in the column of interchangeability are as follows:
 - A..... New parts can take place of old parts, but no vice-versa.
 - B..... No interchangeability between new and old parts.
 - C..... Discontinued.
 - D..... Newly added parts.
 - E..... Both new and old parts applicable.
 - Q..... Quantity altered.
 - e) In the column of applicable machines are shown the machine serial numbers for which the parts in the same column are used.

The year and month appearing there instead of machine serial number means the time of alteration.
 - f) Standards and dimensions of parts are shown in the remarks column.
Note "Inc. ~" in case of supply in assembly.
 - g) In case of _____ line is drawn on the part number, replace that part with the part below.
 - h) The abbreviations have meaning as follows:

ASSY..... ASSEMBLY
 ASS'Y..... ASSEMBLY
 HYD..... HYDRAULIC
 H..... HEAD

CYL..... CYLINDER
 COUN..... COUNTER
 VALA..... VALANCE
 J..... JOINT

INDEX

WORK EQUIPMENT

A11	:	WORK EQUIPMENT (1).....	2
A12	:	WORK EQUIPMENT (2).....	6

UPPER FRAME

B10	:	SWING FRAME	10
B15A	:	FLOOR PLATE	12
B15B	:	FLOOR PLATE	16
B21A	:	CONTROL SYSTEM (1)	20
B21B	:	CONTROL SYSTEM (1)	24
B22	:	CONTROL SYSTEM (2)	28
B23A	:	CONTROL SYSTEM (3)	32
B23B	:	CONTROL SYSTEM (3)	36
B24	:	CONTROL SYSTEM (4)	40
B30	:	TANK UNIT	42
B40	:	ENGINE COVER	44

LOWER MACHINE

C11	:	TRACK FRAME (1)	48
C12	:	TRACK FRAME (2)	50

POWER UNIT

D21	:	POWER UNIT (1)	54
D22	:	POWER UNIT (2).....	58
D23	:	POWER UNIT (3)	60

HYDRAULIC PIPING

E10	:	WORK EQUIPMENT PIPING	66
E11	:	HYD. BREAKER	68
E21	:	UPPER FRAME PIPING(1)	72
E22	:	UPPER FRAME PIPING(2)	76
E23	:	UPPER FRAME PIPING(3)	78
E24	:	UPPER FRAME PIPING(4)	80
E30	:	CHASSIS FRAME PIPING	84

HYDRAULIC COMPONENT

F11	:	CONTROL VALVE(1)	88
F12	:	CONTROL VALVE(2)	90
F20	:	BOOM CYLINDER	92
F22	:	ARM CYLINDER	96
F24	:	BUCKET CYLINDER	98
F26	:	SWING CYLINDER	100
F28	:	DOZER CYLINDER	102
F30	:	EXTENSION CYLINDER	104
F40	:	SWIVEL JOINT	106
F45	:	PUMP	108
F50	:	TRAVEL MOTOR	110
F55	:	TURNING MOTOR	114
F56	:	SELECTOR VALVE	118

ELECTRIC SYSTEM

G10	:	ELECTRIC SYSTEM	122
-----	---	-----------------------	-----

LABEL

H10	:	LABEL	128
-----	---	-------------	-----

OPTION

J21	:	ROOF	132
J22	:	J/D PATTERN CONTROL VALVE	134

WORK EQUIPMENT

WORK EQUIPMENT(1)

A11

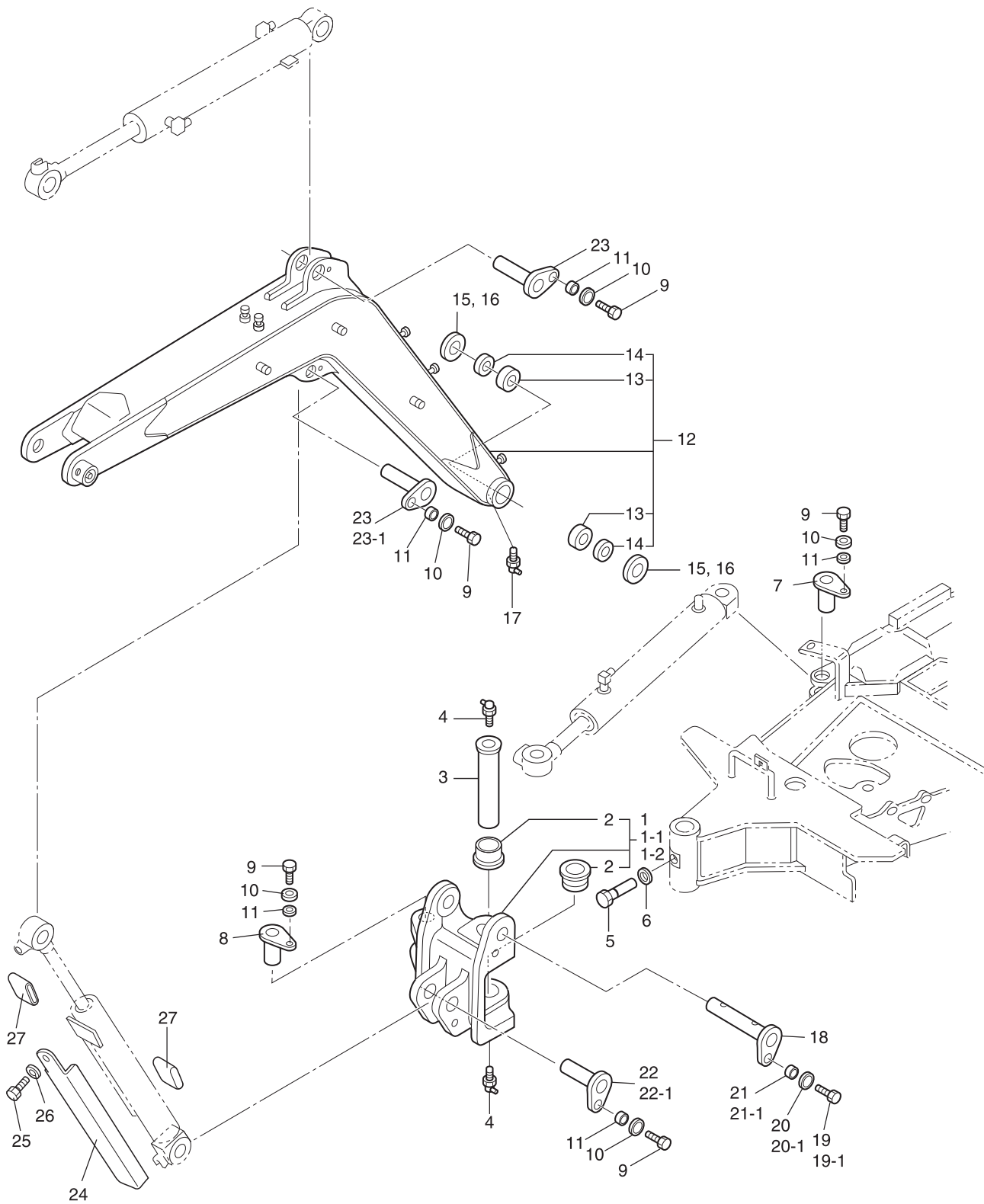

MODEL:H08B

WORK EQUIPMENT(1)

A11

SER. No:H0800051 ~ 99999

Key No.	Part No.	Interchange-ability	Part Name	Q.ty	Applicable Ser. No.	Remarks
◇1	NTS3-11000		SWING POST ASS'Y	1	~H0800136	
◇1-1	NTS3-11000-1	A	SWING POST ASS'Y	1	H0800137~ H0800175	
1-2	NTS3-11000-A	A	SWING POST ASS'Y	1	H0800176~	
*2	NTS3-11012		BUSH	2		
3	NTS3-00027		PIN	1		
4	0542-02000-F		NIPPLE, GREASE 90°	2		
5	NTS3-00030		PIN, LOCK	1		
6	0389-10000-a		WASHER	1		M10
7	NTS1-00600		PIN	1		
8	NTS3-14000-1		PIN	1		
9	0102-08020-a		BOLT	5		M8×20
10	0387-08000-a		WASHER	5		M8
11	NTS1-00045		COLLAR	5		
◇12	NTS3-21000-2		BOOM ASS'Y	1		
*13	NTS3-21017		BUSH	2		
*14	0493-30040-h		SEAL, DUST	2		VAY, 30•40•4
15	NOS3-00005		WASHER	AR		ø31.5×t0.5
16	NOS3-00006		WASHER	AR		ø31.5×t1.0
17	0542-02000-F		NIPPLE, GREASE 90°	1		
18	NTS3-01200-1		PIN	1		
19	0103-12030-a		BOLT	1	~H0800056	M12×30
19-1	0102-08020-a	B	BOLT	1	H0800057~	M8×20
20	0389-12000-a		WASHER	1	~H0800056	M12
20-1	0387-08000-a	B	WASHER	1	H0800057~	M8
21	MBC3-00001-1		COLLAR	1	~H0800056	
21-1	NTS1-00045	B	COLLAR	1	H0800057~	

