

图 1/Fig. 1

平衡重总成/Counter balance assembly

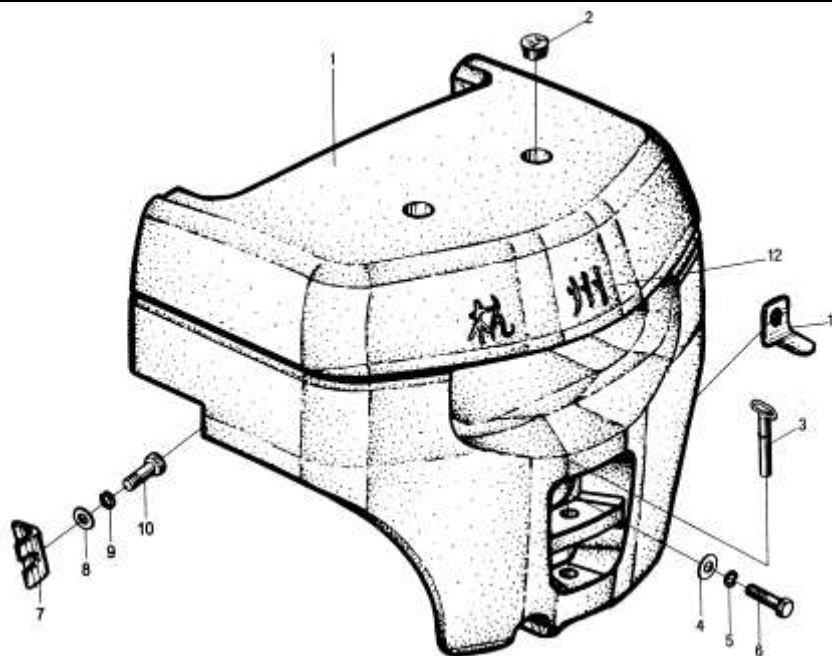

序号 Item	代号 Part NO.	物料码 Material code	名称 Description	数量 Q'ty	日期 Date	备注 Remarks
1	R420-010001-000	70045983	平衡重 Counter balance	1		4t
	R450-010001-000	70041278	平衡重 Counter balance	1		4.5t
	R480-010001-000	70043256	平衡重 Counter balance	1		5t
2	N163-010002-000	70021786	塞子 Plug	2	2008.12.04	
3	R450-011000-000	70041282	牵引销 Towing pin	1		
4	R450-010002-000	70041279	垫圈 Washer	2		
5	GB7244-87	70044669	弹簧垫圈36 Spring washer	2		
6	GB5782-86	20002054	螺栓M36×180 Bolt	2		
7	N163-010007-000	70034002	调整垫片 Adjust shim	4	2008.12.04	
8	GB97.5-85	20000686	垫圈10 Washer	4		

图 1/ Fig. 1

平衡重总成/Counter balance assembly

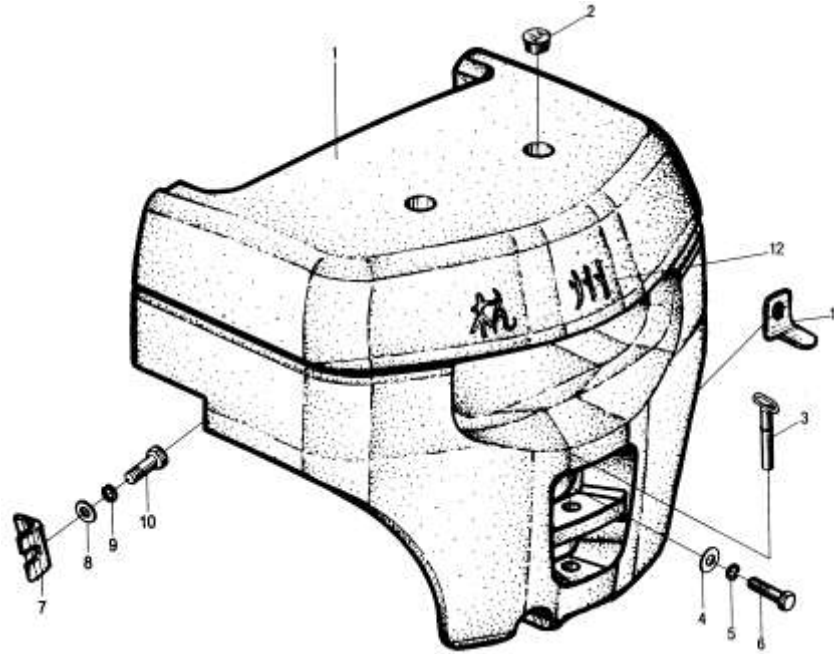

序号 Item	代号 Part NO.	物料码 Material code	名称 Description	数量 Q'ty	日期 Date	备注 Remarks
9	GB93-87	20000003	垫圈10 Washer	4		
10	GB5783-86	20000322	螺栓M10×20 Bolt	4		
11	R450-010003-000	70041280	调整垫片 Adjust shim	2	2008.12.04	
12	R450-010004-000	70041281	铸造字母 Foundry letter	1		

图 2/ Fig. 2

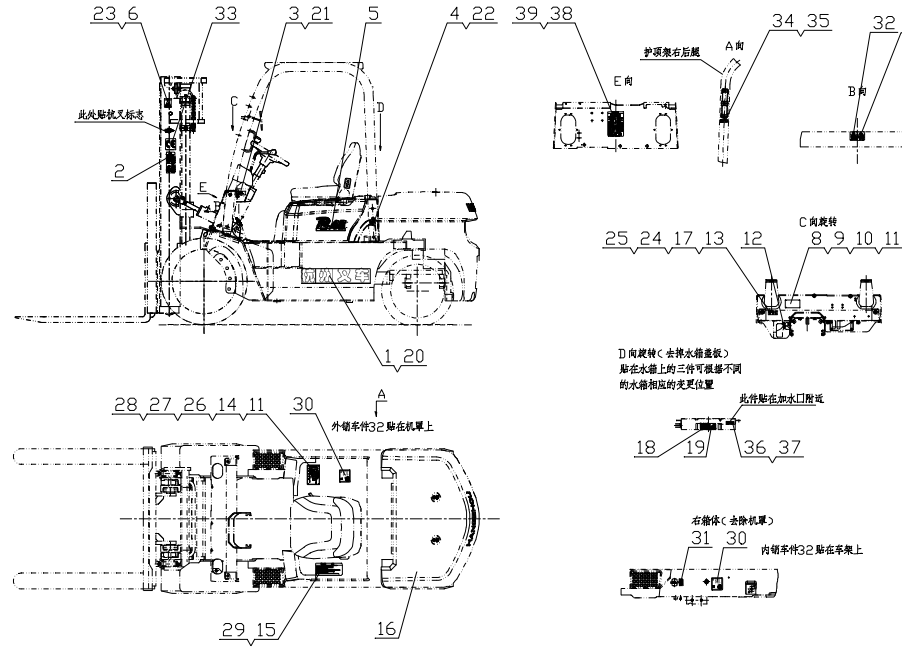

序号 Item	代号 Part NO.	物料码 Material code	名称 Description	数量 Q'ty	日期 Date	备注 Remarks
1	50DH-010008	70031295	字样标签 Script nameplate	2		
2	N163-020002-000	70021793	危险标签 Dangerous nameplate	2		
3	N163-020004-000	70021795	保险丝标签 Fuse nameplate	1		
4	N163-020005-000	70021796	燃油标签 Fuse nameplate	1		
5	R420-020001-000		吨位标签 Ton nameplate	2		4t
	R450-020001-000	70041118	吨位标签 Ton nameplate	2		4.5t
	R480-020001-000	70043276	吨位标签 Ton nameplate	2		5t
6	N163-020008-000	70021799	起吊标签 Lift nameplate	2		
7	N163-020009-000	70021800	危险标签 Dangerous nameplate	1		
8	R420-020002-000		产品铭牌 Product nameplate	1		4t

图 2/ Fig. 2

标示/Nameplate

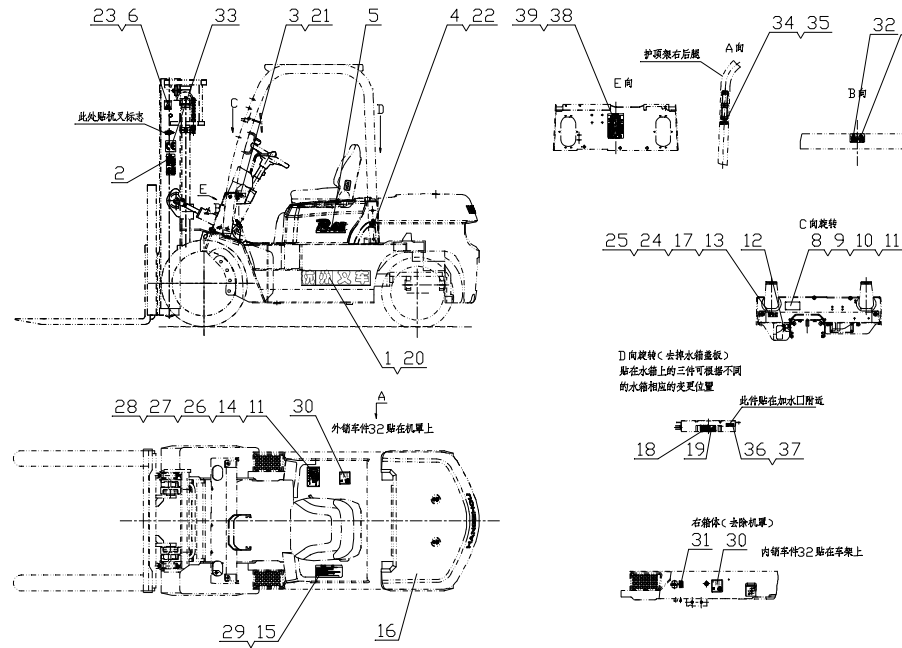

序号 Item	代号 Part NO.	物料码 Material code	名称 Description	数量 Q'ty	日期 Date	备注 Remarks
8	R450-020002-000	70041119	产品铭牌 Product nameplate	1		4.5t
	R480-020002-000	70043277	产品铭牌 Product nameplate	1		5t
9	R420-020003-000		产品铭牌 Product nameplate	1		全英文 4t
	R450-020003-000	70041120	产品铭牌 Product nameplate	1		全英文 4.5t
	R480-020003-000	70043278	产品铭牌 Product nameplate	1		全英文 5t
10	R420-020004-000		产品铭牌 Product nameplate	1		中性 4t
	R450-020004-000	70041121	产品铭牌 Product nameplate	1		中性 4.5t
	R480-020004-000	70043279	产品铭牌 Product nameplate	1		中性 5t
11	GB12618-90	70045232	铆钉4×10 Rivet	8		
12	R450-020005-000	70045962	档位标签 Shift nameplate	1		根据叉车选用

图 2/ Fig. 2

标示/Nameplate

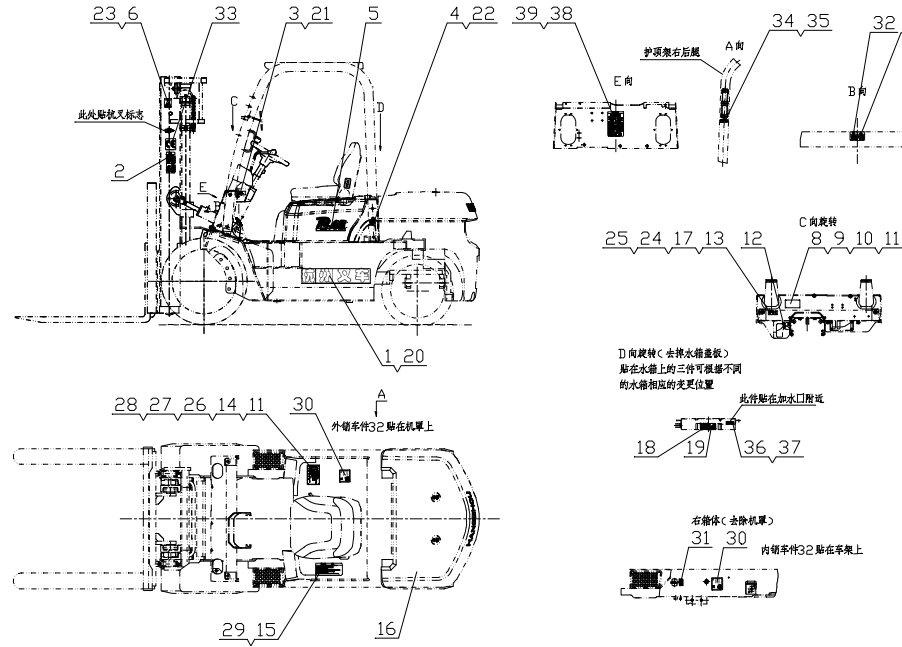

序号 Item	代号 Part NO.	物料码 Material code	名称 Description	数量 Q'ty	日期 Date	备注 Remarks
13	N163-020014-000	70021805	操纵标签1 Operation nameplate	1		仅液力车
14	R420-020005-000		载荷曲线标牌 Load nameplate	1		4t
	R450-020006-000		载荷曲线标牌 Load Nameplate	1		4.5t
	R480-020005-000		载荷曲线标牌 Load nameplate	1		5t
15	N163-020016-000	70021807	警告标签 Warm nameplate	1		
16	R960-020002-000	70033873	配色图 Color nameplate	1		
17	N163-020018-000	70025010	操纵标签2 Operation nameplate	1		仅机械车
18	N163-020019-000	70025011	风扇切手标签 Fan nameplate	1		
19	N163-020020-000	70025012	皮带夹手标签 Fuse nameplate	1		
20	50DH-010012	70045546	字样标签 Characters nameplate	2		全英文

图 2/ Fig. 2

标示/Nameplate

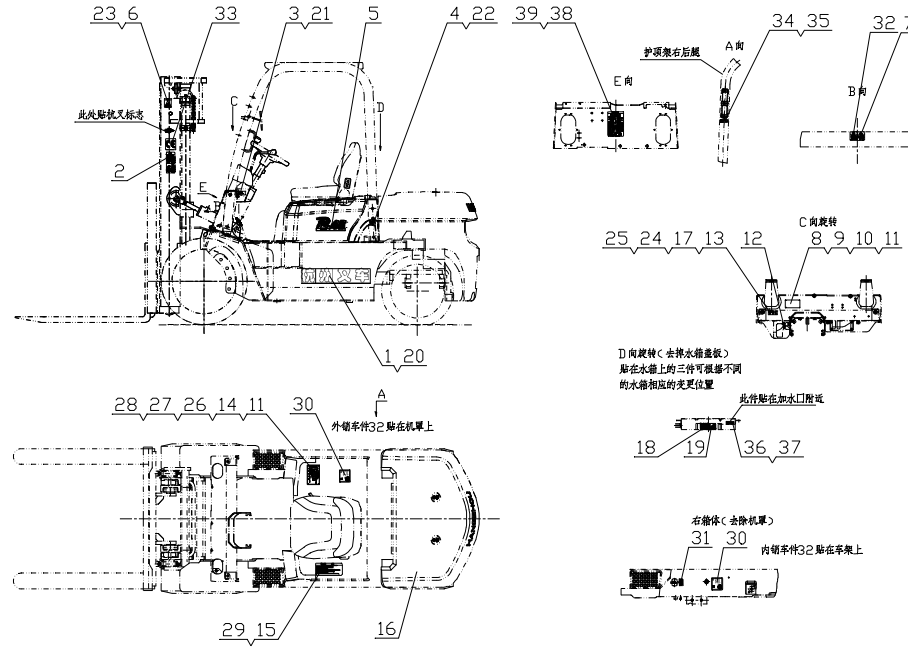

序号 Item	代号 Part NO.	物料码 Material code	名称 Description	数量 Q'ty	日期 Date	备注 Remarks
21	R960-020004-000	70035763	保险丝标签 Fuse nameplate	1		全英文
22	R960-020005-000	70035764	柴油标签 Diesel nameplate	1		全英文
23	R960-020019-000	70045868	起吊标签 Lift nameplate	2		全英文
24	R960-020007-000	70035766	操纵标签1 Operation nameplate	1		全英文液力叉车用
25	R960-020008-000	70035767	操纵标签2 Operation nameplate	1		全英文机械叉车用
26	R420-020006-000		载荷曲线标牌 Load nameplate	1		4t
	R450-020007-000		载荷曲线标牌 Load nameplate	1		4.5t
	R480-020006-000		载荷曲线标牌 Load nameplate	1		5t
27	R420-020007-000		载荷曲线标牌 Load nameplate	1		全英文 4t
	R420-020008-000		载荷曲线标牌 Load nameplate	1	2008.12.04	全英文 4.5t

图 2/ Fig. 2

标示/Nameplate

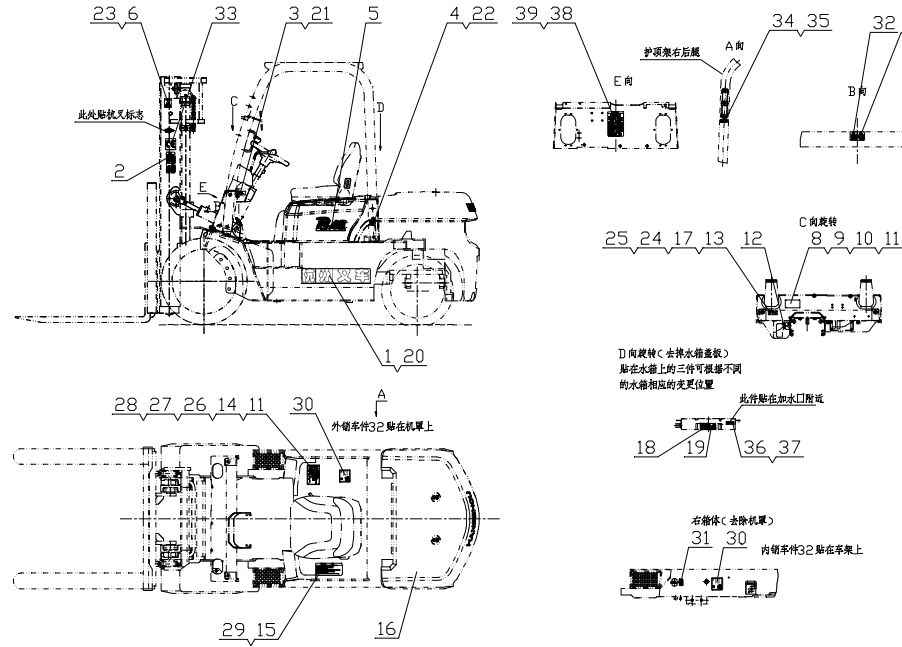

序号 Item	代号 Part NO.	物料码 Material code	名称 Description	数量 Q'ty	日期 Date	备注 Remarks
27	R480-020007-000		载荷曲线标牌 Load nameplate	1		全英文 5t
28	R420-020008-000		载荷曲线标牌 Load nameplate	1		全英文 4t
	R450-020009-000		载荷曲线标牌 Load nameplate	1		全英文 4.5t
	R480-020008-000		载荷曲线标牌 Load nameplate	1		全英文 5t
29	R960-020009-000	70035773	警告标签 Warn nameplate	1		全英文
30	R960-020010-000	70039450	噪音标签 Noise nameplate	1		
31	R960-020011-000	70045543	液压油标签 Hydraulic oil nameplate	1		
32	R960-020015-000	40001665	危险标签 Dangerous nameplate	1		
33	R960-020012-000	40001668	CE标签 CE nameplate	2		
34	R960-020013-000	70045883	严禁冲水标签 No swash nameplate	1		

图 2/ Fig. 2

标示/Nameplate

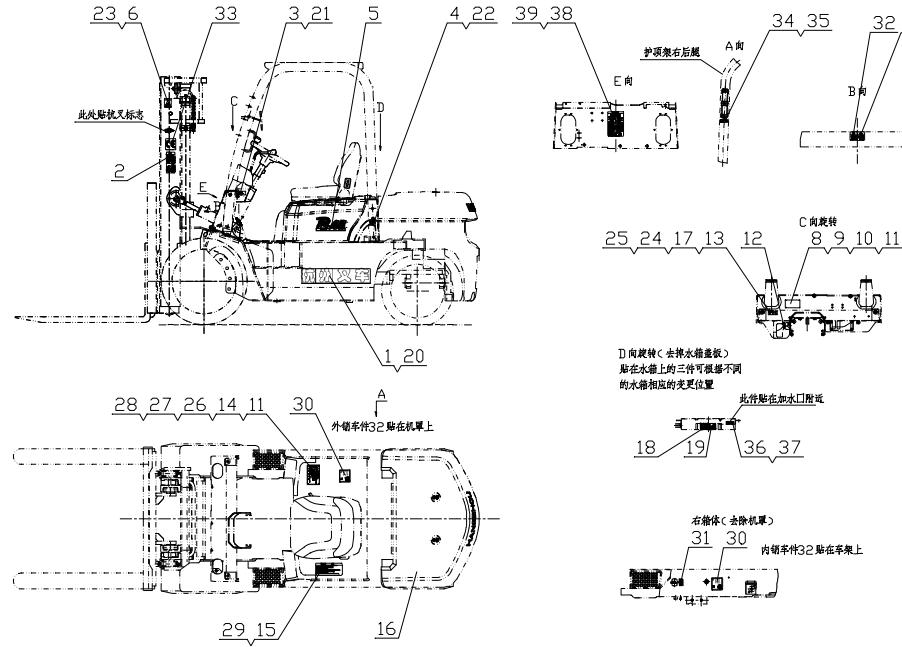

序号 Item	代号 Part NO.	物料码 Material code	名称 Description	数量 Q'ty	日期 Date	备注 Remarks
35	R960-020014-000	40001666	严禁冲水标签 No swashing nameplate	1		全英文
36	R960-020016-000	70045544	防冻液标签 Antifreeze nameplate	1		
37	R960-020017-000	70045545	防冻液标签 Antifreeze nameplate	1		全英文
38	R960-020020-000	70045537	润滑系统标签 Lubrication system nameplate	1		
39	R960-020021-000	70045538	润滑系统标签 Lubrication system nameplate	1		全英文

图 3/Fig. 3

座椅总成/Seat assembly

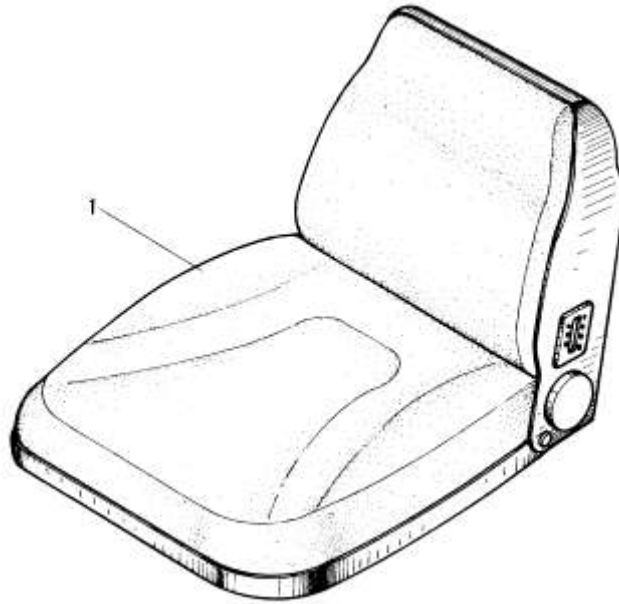

序号 Item	代号 Part NO.	物料码 Material code	名称 Description	数量 Q'ty	日期 Date	备注 Remarks
1	R960-030001-G00	11009834	座椅 Seat	1		
	R969-030001-G00	11009896	座椅 Seat	1		

图 4 /Fig. 4

- © CPC40/45-RG31
 ④ CPC50-RXG24

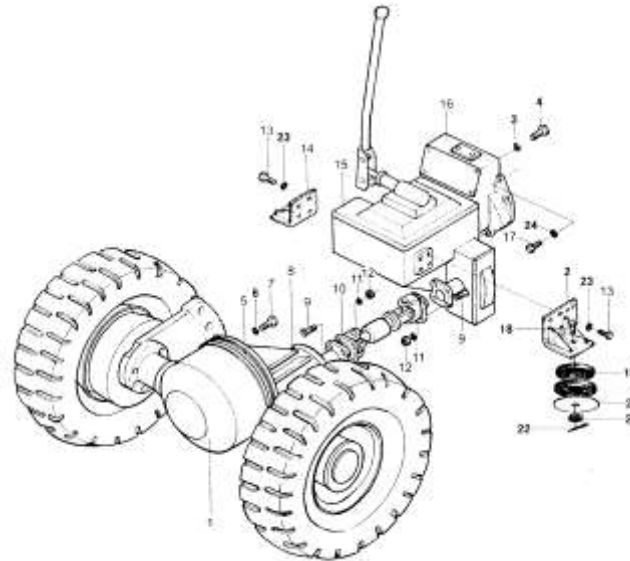

序号 Item	代号 Part NO.	物料码 Material code	名称 Description	数量 Q'ty	日期 Date	备注 Remarks
1	R441-110000-000	70043930	驱动桥 Drive axle	1		
2	H510-103000-000	70031753	变速器左支架 Mechanical transmission left bracket	1		
3	GB93-87	20000178	垫圈 16 Washer	4		
4	GB5783-86	20000332	螺栓 M16×50 Bolt	4		
5	JP451-100001-000	70043559	垫 Gasket	1		
6	GB7244-87	20003494	垫圈 12 Washer	12		
7	GB5783-86	20000002	螺栓 M12×35 Bolt	12		
8	EQ1092F-G00	11009107	主减速器 Reduction transmission	1		
9	H510-100001-000	70031733	螺栓 Bolt	8		

图 4 /Fig. 4

- © CPC40/45-RG31
 ① CPC50-RXG24

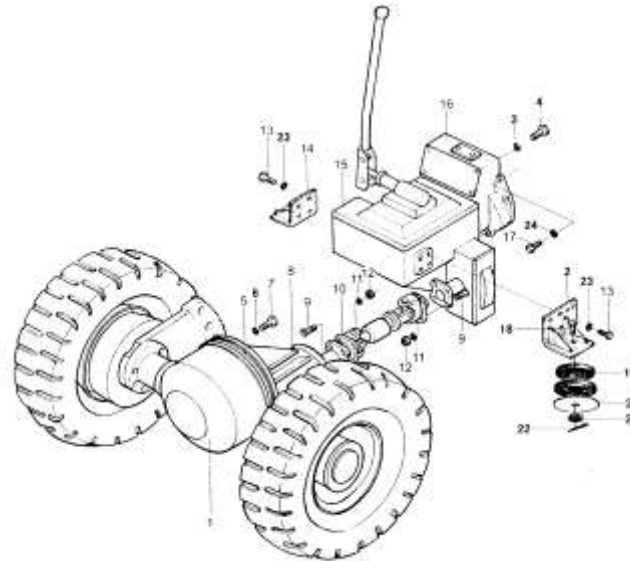

序号 Item	代号 Part NO.	物料码 Material code	名称 Description	数量 Q'ty	日期 Date	备注 Remarks
10	H510-101000-000	70031734	传动轴总成 Driving shaft	1		
11	GB93-87	20000036	垫圈 14 Washer	8		
12	GB6184-86	20005357	螺母 M14 Nut	8		
13	GB5783-86	20000119	螺栓 M12×30 Bolt	8		
14	H510-102000-000	70031736	变速器右支架 Mechanical transmission left bracket	1		
15	R441-120000-000	70043935	变速器 Transmission	1		©
	R470-120000-000			1		①
16	R441-130000-000	70043980	离合器 Clutch	1		©
	R470-130000-000			1		①

图 4 /Fig. 4

传动系统/Driving system

- © CPC40/45-RG31
 ① CPC50-RXG24

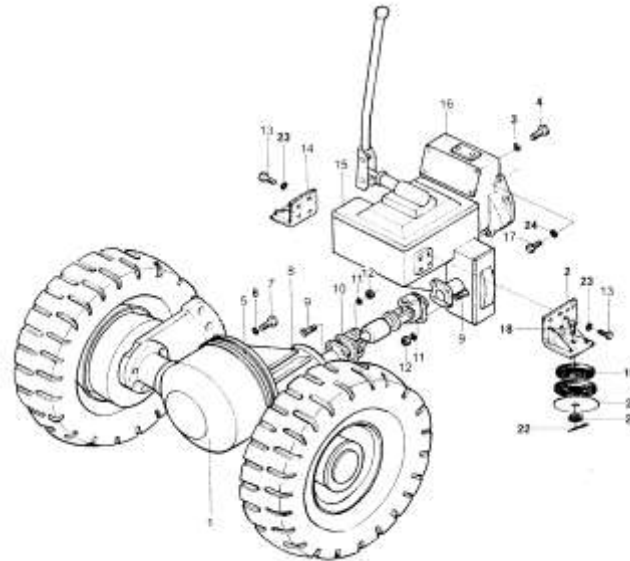

序号 Item	代号 Part NO.	物料码 Material code	名称 Description	数量 Q'ty	日期 Date	备注 Remarks
17	GB5783-86	20000005	螺栓 M12×40	10		©
	GB5783-86	20000090	螺栓 M10×35	12		①
18	H510-100002-000	70038759	螺栓	2		
19	CB2204-4-G00	70043191	减震垫	2		
20	H510-100003-000	70038760	垫片	2		
21	GB6178-86	20004198	螺母 M24	2		
22	GB91-86	20005279	销 5×45	2		
23	GB93-87	20000001	垫圈 12	8		
24	GB93-87	20000001	垫圈 12	10		©
	GB93-87	20000003	垫圈 10	12		①

图 5 /Fig. 5

传动系统/Driving system

- Ⓐ CPCD40/45-RG24
- Ⓑ CPCD50-RXG24
- Ⓔ CPCD40/45-RW5
- Ⓕ CPCD50-RXW5
- Ⓖ CPCD40/45-RW17-Y
- Ⓗ CPCD50-RXW17-Y
- Ⓘ CPCD40/45-RW19
- Ⓙ CPCD50-RXW19

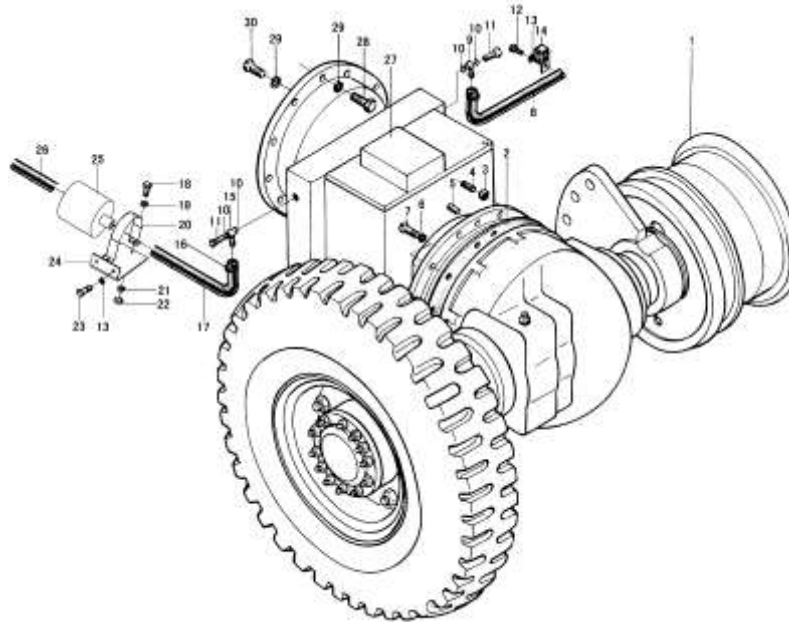

序号 Item	代号 Part NO.	物料码 Material code	名称 Description	数量 Q'ty	日期 Date	备注 Remarks
1	R450-110000-000	70040886	驱动桥 Drive axle	1		
2	40DH-100001	70012800	垫圈 Washer	1		
3	GB6170-86	20000019	螺母 M12 Nut	2		
4	GB898-88	20002418	螺柱 M12×30 Stud	2	2008.12.04	
5	GB120-86	20001835	销 B10×35 Pin	1		
6	GB93-87	20000001	垫圈 12 Washer	12		
7	GB5783-86	20000002	螺栓 M12×35 Bolt	10		
8	R450-100002-W00	70040884	低压胶管 Rubber pipe	1		
9	40DH-100010	70036577	接头体 Connector	1		

图 5 /Fig. 5

传动系统/Driving system

- Ⓐ CPCD40/45-RG24
- Ⓑ CPCD50-RXG24
- Ⓔ CPCD40/45-RW5
- Ⓕ CPCD50-RXW5
- Ⓖ CPCD40/45-RW17-Y
- Ⓗ CPCD50-RXW17-Y
- Ⓘ CPCD40/45-RW19
- Ⓙ CPCD50-RXW19

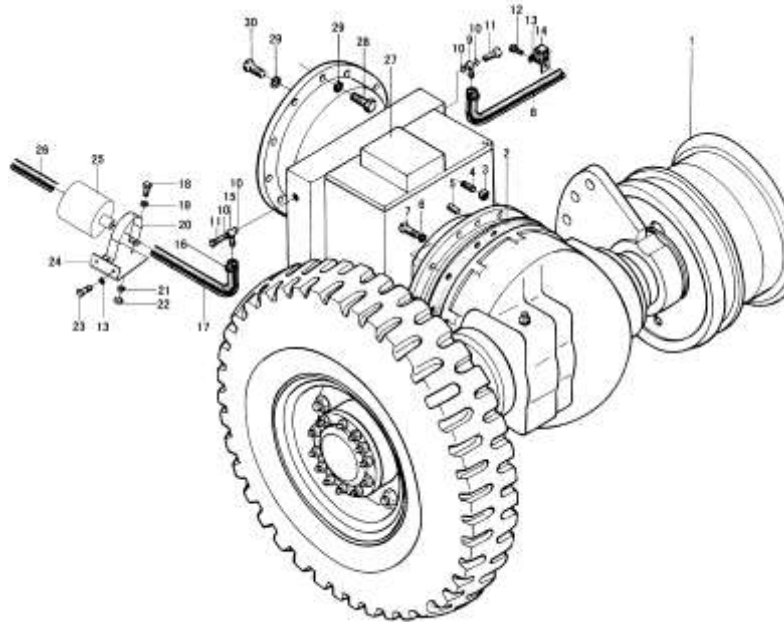

序号 Item	代号 Part NO.	物料码 Material code	名称 Description	数量 Q'ty	日期 Date	备注 Remarks
10	GB1235-76	20003948	O形密封圈 26×2.4 O-ring	4		
11	40DH-100003	70015337	铰接螺栓 Bolt	2		
12	GB5783-86	20000107	螺栓 M8×16 Bolt	3		
13	GB93-87	20000026	垫圈 8 Washer	7		
14	R450-600003-000	70040902	抱箍 Clamp	3		
15	40DH-100009	70036576	接头体 Connector	1		
16	Q672-32-G00	11000464	双钢丝环箍 32 Clamp	6		
17	R450-100001-W00	70040885	低压胶管 Rubber pipe	1		
18	GB5783-86	20000240	螺栓 M6×16 Bolt	2		

图 5 /Fig. 5

传动系统/Driving system

- Ⓐ CPCD40/45-RG24
- Ⓑ CPCD50-RXG24
- Ⓔ CPCD40/45-RW5
- Ⓕ CPCD50-RXW5
- Ⓖ CPCD40/45-RW17-Y
- Ⓗ CPCD50-RXW17-Y
- Ⓘ CPCD40/45-RW19
- Ⓙ CPCD50-RXW19

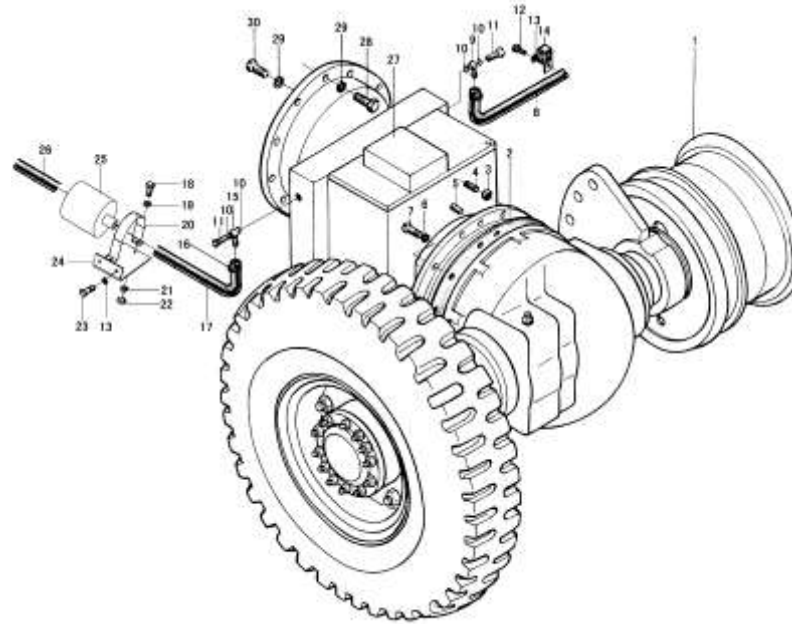

序号 Item	代号 Part NO.	物料码 Material code	名称 Description	数量 Q'ty	日期 Date	备注 Remarks
19	GB97.1-85	20000785	垫圈 6 Washer	2		
20	40DH-100007	70036575	抱箍 Clamp	1		
21	GB93-87	20000054	垫圈 6 Washer	2		
22	GB6170-86	20001827	螺母 M6 Nut	2		
23	GB5783-86	20003916	螺栓 M8×18 Bolt	2		
24	40DH-100006	70036574	支架 Bracket	1		
25	YK0812A5-0000-G00	11010071	液压滤清器 Hydraulic oil filter	1		
26	R450-100003-W00	70040883	低压胶管 Rubber pipe	1		

图 5 /Fig. 5

传动系统/Driving system

- Ⓐ CPCD40/45-RG24
- Ⓑ CPCD50-RXG24
- Ⓔ CPCD40/45-RW5
- Ⓕ CPCD50-RXW5
- Ⓖ CPCD40/45-RW17-Y
- Ⓗ CPCD50-RXW17-Y
- Ⓘ CPCD40/45-RW19
- Ⓝ CPCD50-RXW19

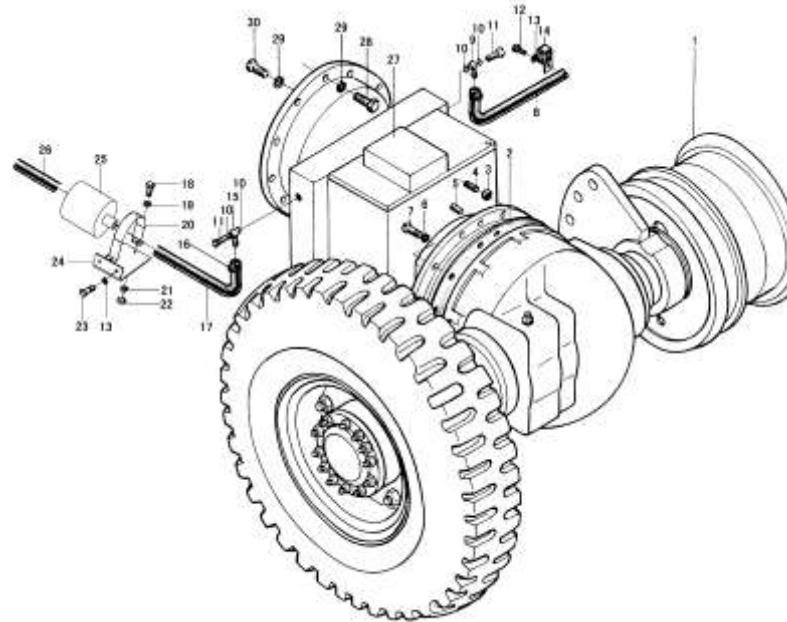

序号 Item	代号 Part NO.	物料码 Material code	名称 Description	数量 Q'ty	日期 Date	备注 Remarks
27	R450-120000-000	70043773	液力传动变速箱 Automatic transmission	1		Ⓐ Ⓑ
	R454-120000-000	70043380		1		Ⓔ Ⓕ
	R453-120000-000	70041797		1		Ⓖ Ⓗ
	YQX45 IIIA			1		Ⓘ Ⓝ
28	GB5783-86	20000090	螺栓 M10×35 Bolt	12		
29	GB93-87	20000003	垫圈 10 Washer	20		
30	GB5783-86	20000009	螺栓 M10×25 Bolt	10		

图 6 /Fig. 6

驱动桥(一)/Drive axle(I)

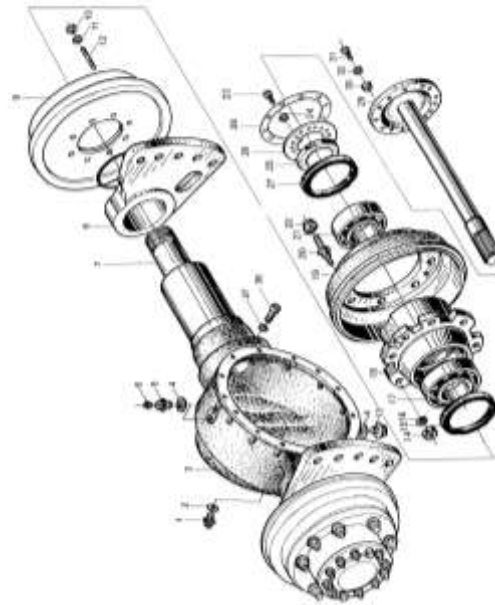

序号 Item	代号 Part NO.	物料码 Material code	名称 Description	数量 Q'ty	日期 Date	备注 Remarks
1	JB1000-77	20005154	螺塞 M16×1.5 Plug	1		
2	JB982-77	20000205	垫圈 16 Washer	1		
3	R450-111002-000	70040889	桥壳 Axle body	1		Ⓐ Ⓑ Ⓔ Ⓕ Ⓖ Ⓕ
	JP451-111001-000	70043554	桥壳 Axle body	1		Ⓒ Ⓓ
4	JB982-77	20001082	垫圈 22 Washer	2		
5	N163-110017-000	70002528	螺塞 Plug	1		
6	Q900-Z1/8-G00	11007393	通气塞 Z1/8" Vent plug	1		
7	R450-111001-000	70040888	轴管 Bushing	2		Ⓐ Ⓑ Ⓔ Ⓕ Ⓖ Ⓕ
	JP451-111002-000	70043553	左套管 Plug(left)	1		Ⓒ Ⓓ
	JP451-111003-000	70043555	右套管 Plug(right)	1		

图 6 /Fig. 6

驱动桥(一)/Drive axle (I)



序号 Item	代号 Part NO.	物料码 Material code	名称 Description	数量 Q'ty	日期 Date	备注 Remarks
8	R450-110002-000	70040891	右支撑板 Plate(right)	1		Ⓐ Ⓑ Ⓔ Ⓕ Ⓖ Ⓕ
	R450-110001-000	70040890	左支撑板 Plate(left)	1		Ⓐ Ⓑ Ⓔ Ⓕ Ⓖ Ⓕ
	R441-110002-000	70043932	右支撑板 Plate(right)	1		Ⓒ Ⓓ
	R441-110001-000	70043931	左支撑板 Plate(left)	1		Ⓒ Ⓓ
9	R450-114000-000	70040893	制动器 (右) Brake(right)	1		
	R450-113000-000	70040892	制动器 (左) Brake(left)	1		
10	GB6171-86	70044441	螺母 M14×1.5 Nut	16		
11	GB93-87	20000036	垫圈 14 Washer	16		
12	40DH-110003	70024633	螺柱 Stud	16		Ⓐ Ⓑ Ⓔ Ⓕ Ⓖ Ⓕ
	H510-110005-000	70031727	螺柱 Stud	16		Ⓒ Ⓓ

图 6 /Fig. 6

驱动桥(一)/Drive axle(I)

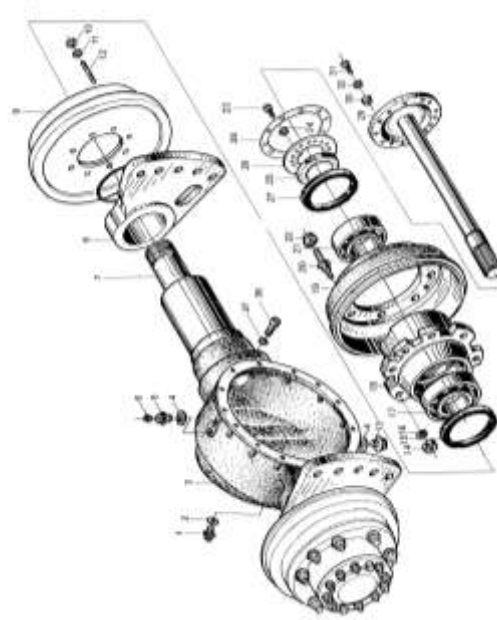

序号 Item	代号 Part NO.	物料码 Material code	名称 Description	数量 Q'ty	日期 Date	备注 Remarks
13	JB1001-77	20000229	螺塞 M22×1.5 Plug	1		
14	GB6171-86	20004986	螺母 M20×1.5 Nut	16		
15	HG4-692-67-G00	11010591	油封 PD160×115×14 Oil seal	2		
16	GB93-87	20000115	垫圈 20 Washer	16		
17	GB/T297-94	20002210	轴承 32217 Bearing	2		
18	R450-110003-000	70040897	轮毂 Hub	2		
19	R450-110004-000	70040896	制动鼓 Brake drum	2		
20	R450-110007-000	70040895	轮毂螺栓 Hub bolt	16		
21	GB297-84		轴承 7815 Bearing	2		

图 6 /Fig. 6

驱动桥(一)/Drive axle(I)



序号 Item	代号 Part NO.	物料码 Material code	名称 Description	数量 Q'ty	日期 Date	备注 Remarks
22	N163-110015-000	70002524	轮毂螺母 Hub nut	16		
23	GB5783-86	20000573	螺栓 M6×12 Bolt	4		
24	GB93-87	20003801	垫圈 6 Washer	4		
25	R450-110006-000	70040898	锁紧螺母 Lock nut	2		
26	N163-110011-000	70021920	锁紧片 Lock washer	2		
27	HG4-692-67-G00	11010592	油封 PD140×110×14 Oil seal	2		
28	R450-110008-000	70040900	纸垫 Gasket	2		
29	R450-110005-000	70040899	半轴 Half-axle	2		Ⓐ Ⓑ Ⓔ Ⓕ Ⓖ Ⓕ
	JP451-110001-000	70043557	左半轴 Left half-axle	1		Ⓒ Ⓓ
	JP451-110002-000	70043558	右半轴 Right half-axle	1		