



**1t-3.5t R Series Internal Combustion
Counterbalanced Forklift Truck**

SERVICE MANUAL



HANGCHA GROUP CO., LTD.

Jun. 2011 5th EDITION

Foreword

The manual is the introduction of structure, working principle and serving of 1t-3.5t R series internal combustion counterbalance forklift truck.

For safety and performance of truck, all in charge of operation, maintenance and management must read and comprehend this manual well.

The manual also applies to container fork-lift trucks.

It is forbidden anybody without training and qualification to maintain.

Our product design will update and perform better, so the content in this manual may be not the same as the forklift you owned.

If you have any questions please keep touches with HANGCHA GROUP CO., LTD. sales department or let the agents know.

Content

Foreword

I . Power System.....	1
1. Engine for Forklift	1
2. NISSAN K21、K25 gasoline	3
3. C240 PKJ-30 Diesel	12
4. TD27AA diesel.....	14
II . Hydrodynamic transmission,torque converter	17
1. Summary	17
2. Data.....	18
3. Working principles	19
4. Structure.....	21
5. Notice about installation and usage.....	30
6. Cause and solutions.....	30
III. Driving axle	31
1. Date.....	31
2. Trouble diagnoses and corrections.....	31
3. Assembly and disassembly of driving axle	32
4. Axle shaft and wheel hub.....	33
5. Bearing adjusting.....	34
IV. Steering axle	36
1. General specifications	36
2. Trouble diagnoses corrections.....	36
3. Steering axle.....	38
4. Kingpin and steering spindle.	38
5. Wheel bearing adjustment.....	38
V . Steering system	39
1. Data.....	39
2.Trouble diagnoses	39
3. Summarize	40
4. Install steering system	42
VI. Brake system	43
1.Trouble and diagnoses and corrections.....	43
2. Summary.....	44
VII.Hydraulic system.....	48
1. Data	48
2. Trouble diagnoses and corrections	50
3. Main pump.....	52
4. Control valve	55
5. Hydraulic piping.....	57

VIII. Lifting system	59
1. Assemble debugging data	59
2. Trouble diagnoses and corrections.....	60
3. Summary	63
4. Removal and adjustment.....	69
5. Disassembly and installation of lifting jack.....	73
6. Disassembly and installation of tilting cylinder	74
7. Noticing proceeding of debugging	75
IX. Electrical system	77

I . Power System

1. Engine for Forklift

Engine Parameter	Gasoline	
	K21(Japan)	K25(Japan)
Rated output kW	37	44
Rated rotate speed r/min	2300	2500
Max. torque N·m / Speed r/min	142/1600	179/1600
Service weight kg	158	161
Forklift truck model	CPQ10/15/18N- RW21 CPQD10/15/18N- RW21	CPQ20/25/30/35N -RW22 CPQD20/25/30/35N -RW22 CPQD20/25/30/35N - RW22A CPQD20/25/30/35N- RW22B

Engine Parameter	Diesel	
	C240PKJ-20	C240PKJ-30
Rated output kW	35	35
Rated rotate speed r/min	2500	2500
Max. torque N·m / Speed r/min	139/1800	139/1800
Service weight kg	252	252
Forklift truck model	CPC10/15/18N -RW9 CPCD10/15/18N -RW9 CPC20/25/30/35N -RW9 CPCD20/25/30/35N-RW9 CPC20/25/30/35N-RW9B CPCD20/25/30/35N-RW9B	CPC10/15/18N-RW10 CPCD10/15/18N-RW10 CPC20/25/30/35N-RW10 CPCD20/25/30/35N-RW10 CPC20/25/30/35N-RW10B CPCD20/25/30/35N-RW10B

Engine Parameter	Gasoline	LPG single fuel	Diesel
	BY491GP (Baiyang)	IMPCO GM3.0L	A498BT1-1
Rated output kW	38	50	36.8
Rated rotate speed r/min	2600	2500	2400
Max. torque N·m / Speed r/min	161/1800-2200	189 /1600	186/1600~1800
Forklift truck model	CPQ(D)10/15/18N-RW7 CPQ(D)20/25/30N-RW7	CPQD20/25N-RW26-Y CPQD30/35N-RW26-Y	CPCD20/25N-RW27 CPCD30/35N-RW27

Engine Parameter	Diesel	Diesel (YANMAR)	
	TD27AA (NISSAN)	4TNE92-HRJ	4TNE98-BQFLC
Rated output kW	38.5	32.8KW	44.3KW
Rated rotate speed r/min	2300	2450	2300
Max. torque N·m / Speed r/min	160/2300	149.4 / 1600	206 /1700
Service weight kg	243	194	194
Forklift truck model	CPCD20/25N -RW15A CPCD30/35N -RW15A	CPCD10/15/18N-RW32 CPCD20/25N-RW32 CPCD30/35N-RW32	CPCD20/25N-RW33 CPCD20/25N-RW33B CPCD20/25N-RW33M CPCD30/35N-RW33 CPCD30/35N-RW33B CPCD30/35N-RW33M

Specifications, structure and maintenance methods for engine see ENGINE MAINTENANCE MANUAL.

Specifications, structure and maintenance methods for model TD27AA engine see 《KEY COMPONENTS IMPORTED FROM NISSAN SERVICE MANUAL》 .

Check value of end gas after maintaining engine, and the value must be according to following figure:

Engine power (kW)	CO (g/kW·h)	HC (g/kW·h)	NO ₂ (g/kW·h)	PT(particle) (g/kW·h)
18 ≦ P < 37	5.5	1.5	8	0.8
37 ≦ P < 75	5	1.3	7	0.4

2. NISSAN K21、K25 gasoline

2.1 Specification

Specification		Gasoline		
Model		K21	K25	
Type		Water cooled, four cycle, in-line overhead valve type		
Cylinder: No. —stroke mm		4 — 89	4 — 89	
Displacement L		1.982	2.472	
Direction of rotation		Clockwise cooling fan		
Firing order		1-3-4-2		
Valve clearance mm	Intake(Hot)	0.38		
	Exhaust(Hot)	0.38		
Cooling System		Water-cooled, forced circulation		
Lubrication System		Forced Lubrication		
Main component	Carburetor model		210030-41 210030-42	
	Fuel pump		Film-type	
	Air clear		Paper element	
	Oil pump		Gear type	
	Oil filter		Paper element	
	Water pump		Centrifugal	
	Thermostat		Wax-pellet type	
	Standard clearance of switchboard		0. 35-0. 45	
	Spark plug	Type		FR2A-D
		Plug gap(mm)		0.8~0.9
	Generat or	Type		A7T03371
		Voltage V	12	
		current A	35	
	Starter	Type		M000T65381 (Planetary gear type)
		Voltage V	12	
		Output power kW	1.2	
	Governor	Type		Pneumatic
		Speed control system		By controlling mix. tare amount
		Operation of control mechanizing		By suction negative pressure
		Max. Engine speed under no-laden		3600 r/min
		Max. Engine speed under laden		3000 r/min
	Battery	Type		/
		Capacity V-A·h		12-60
		Full charge specific gravity at 20°C		1.28
	Reference data	Engine oil capacity L	3.7	
		Coolant volume L	3.5	

2.2K21/K25 Maintenance

2.2.1 Retighten cylinder head bolts

When the engine is cold, retighten should be made in the sequence shown.

-T: 68.6 N·m

-In two steps.

2.2.2 Adjusting intake and exhaust valve clearance

1) Start engines and warm it up sufficiently.

Then turn off engine.

2) Remove valve rocker cover.

3) Rotate crankshaft.

Set No.1 cylinder in top dead center on its compression stroke and then adjust valve clearance.

① ② ③ ⑤

Set NO.4 cylinder in top dead center on its compression stroke, and adjust valve clearance.

④ ⑥ ⑦ ⑧

Valve clearance (Hot)

Intake & exhaust: 0.38mm

2.2.3. Checking and Adjusting Fan Belt for Tension

1) Visually inspect for cracks, fraying, wear or lubricity.

The belt should not touch the bottom of the pulley groove.

2) Check belt deflection by pushing midway between pulleys.

Fan belt deflection: 11mm~13mm

Pushing force: 98N

2.2.4. Changing engine oil and oil filter

1) Start engine and warm up engine sufficiently, then stop engine.

2) Remove oil filler cap and oil pan drain plug, and allow oil to drain.

WARNING:

Be careful not to burn yourself, as the engine oil may be hot.

- Milky oil indicates the presence of cooling water and finds the cause, takes corrective measure.

- Oil with extremely low viscosity indicates dilution with gasoline.

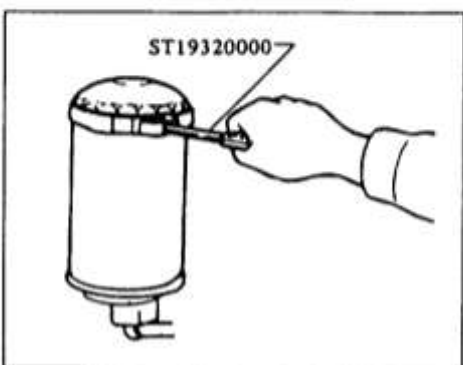
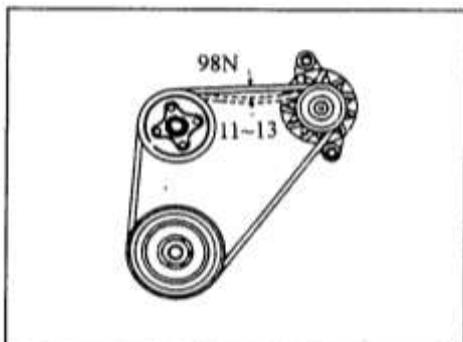
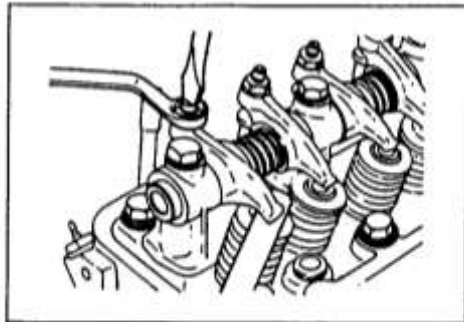
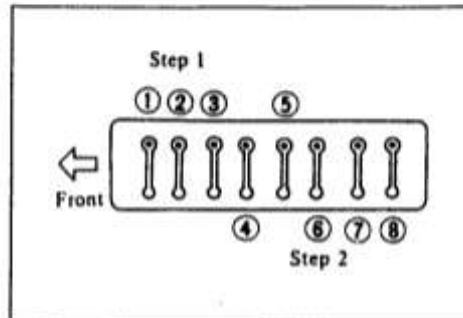
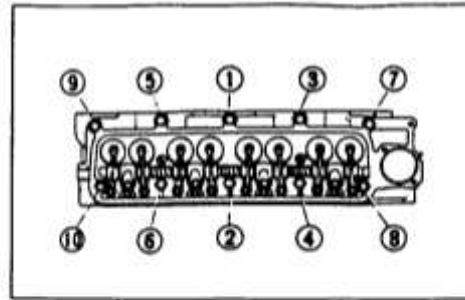

- 3) Clean and install oil pan drain plug with washer.
- Oil pan drain plug: 29N·m~39N·m
- 4) Using tool remove oil filter.
- 5) Wipe oil filter mounting surface with a clean rag.
- 6) Smear a little engine oil on rubber gasket of new oil filter.
- 7) Install new oil filter. Hand-tighten ONLY.

Don't use a wrench to tighten the filter.

- 8) Refill engine with new recommended engine oil, referring to Recommended Lubricants. Check oil level with dipstick. Oil capacity: 3.6 L.
 - 9) Start engine, check area around drain plug and oil filter for any sign of oil leakage. If any Leakage is evident, these parts have not been properly installed.
 - 10) Warm up engine sufficiently. Then stop engine and wait a few minutes. Check oil level. If necessary, add engine oil.
- When checking oil level, park the forklift on a level surface.

2.2.5. Changing Engine Coolant

WARNING:

To avoid the danger of being scalded, never attempt to change the coolant when the engine is hot. When using anti-freeze coolant, mix the anti-freeze coolant with water.

2.2.6. Cleaning Radiator Outside

Clean outside of radiator with dry compressed air.

2.2.7. Checking cooling System, Hoses and Connections.

Check hoses and fittings for Lose connections or deterioration. Retighten or replace if necessary.

