



16 吨内燃平衡重式叉车

16t Counterbalance Internal Combustion Forklift Truck

零件目录 Parts Catalogue

浙江杭叉工程机械股份有限公司

ZHEJIANG HANGCHA ENGINEERING MACHINERY CO., LTD

2007.6 1st Edition

说 明

1、本“零件目录”汇集了 16t 系列内燃叉车的零部件。

2、查询方法：

①用户可根据目录中各总成图查找所需的零部件的序号，根据序号可查得相应的图号或标准号。

②本目录中凡各种叉车通用的零件在目录中不加说明，不通用件除了在目录的右上角表示此总成所适用的车型代号和车型外，还在相应的备注中予以车型代号区别。如第 21 页图 11，目录右上角“Ⓐ Ⓑ”为车型代号，第 2 行（序号 2）中的Ⓐ表示该零件用于 CPCD160-W2 叉车。

3、订购零件时，须写明所用叉车的型号，出厂编号，所需零部件代号、名称及订购数量。

4、维修更换零部件时，为确保质量，请使用本厂零部件。

5、为提高质量，本厂将对某些零部件进行改进，对改进部分在本目录中不能同时一一修改，请用户谅解，欲了解详细情况可与本公司销售公司及备件处联系。

6、型号含义：

型 号	发 动 机	变 速 箱	额定起重量(t)/载荷中心距(mm)
Ⓐ CPCD160-W2	6BTA5.9	3WG-171	16/900
Ⓑ CPCD160-W25	QSB6.7		

INFORMATION

I .This parts list collects all of the parts (components)16 ton fork lift trucks.

II .Looking up methods:

I) First looking up the series number of the part (component) in the drawings of the assembly, in which the part (component) is in the parts list and then the codes of the drawing and standard of the part (the component) in terms of the series number.

II) No noted are all of the same parts and components otherwise they should be noted in case of difference.

For example, in fig. 11, the top right corner in page 21, “Ⓐ Ⓑ” means the type of the truck. In the 2th line (No.2), “Ⓐ” means this part use only in CPCD160-W2 type fork lift truck.

III. Model, series Number, code Number of drawing and quantity should be given when ordering the spare parts.

IV. It is recommended to use the parts and components made by us for ideal the service and maintenance.

V. We reserve the right of the change of the truck in construction for improving our products without notice. For the details of changes, please consult with sales department of Hangzhou Forklift Truck Co., ltd.

VI. Type explanation

目 录

Contents

注：Ⓐ CPCD160-W2 Ⓑ CPCD160-W25

Note : Ⓐ CPCD160-W2 Ⓑ CPCD160-W25

序号 Item	名 称 Description	适用车型 Series No.	页 码 Page
图 1 Fig.1	标示 Nameplate	Ⓐ、Ⓑ	1
图 2 Fig.2	传动系统 Driving system	Ⓐ、Ⓑ	5
图 3 Fig.3	转向桥 Steering axle	Ⓐ、Ⓑ	8
图 4 Fig.4	转向油缸 Steering cylinder	Ⓐ、Ⓑ	12
图 5 Fig.5	转向轮胎 Steering tyre	Ⓐ、Ⓑ	13
图 6 Fig.6	转向装置 Steering device	Ⓐ、Ⓑ	14
图 7 Fig.7	动力系统 Drive system	Ⓐ	15
图 8 Fig.8	动力系统 Drive system	Ⓑ	16
图 9 Fig.9	进气系统 Air inlet system	Ⓐ	17
图 10 Fig.10	进气系统 Air inlet system	Ⓑ	19
图 11 Fig.11	排气系统 Exhaust system	Ⓐ、Ⓑ	21
图 12 Fig.12	冷却系统 Cooling system	Ⓐ	22
图 13 Fig.13	冷却系统 Cooling system	Ⓑ	24
图 14 Fig.14	燃油系统 Fuel system	Ⓐ	27
图 15 Fig.15	燃油系统 Fuel system	Ⓑ	29
图 16 Fig.16	发动机安装 Engine mount	Ⓑ	31
图 17 Fig.17	车身系统 Truck body system	Ⓐ、Ⓑ	32

图 18 Fig.18	液压油箱总成 Oil tank assembly	Ⓐ 、 Ⓑ	35
序号 Item	名 称 Description	适用车型 Series No.	页 码 Page
图 19 Fig.19	燃油箱总成 Fuel tank assembly	Ⓐ 、 Ⓑ	37
图 20 Fig.20	平衡重总成 Counter balance assembly	Ⓐ 、 Ⓑ	38
图 21 Fig.21	小油箱 Small oil tank	Ⓐ 、 Ⓑ	39
图 22 Fig.22	机罩总成 Cover assembly	Ⓐ 、 Ⓑ	40
图 23 Fig.23	后视镜总图 Rear view mirror assembly	Ⓐ 、 Ⓑ	42
图 24 Fig.24	制动与微动操纵 Brake and inching control	Ⓐ 、 Ⓑ	43
图 25 Fig.25	微动踏板总成 Slight travel pedal assembly	Ⓐ 、 Ⓑ	47
图 26 Fig. 26	油门操纵 Throttle control	Ⓐ	48
图 27 Fig.27	油泵总成及液压油箱附件 Pump assembly and oil tank accessory	Ⓐ	49
图 28 Fig.28	油泵总成及液压油箱附件 Pump assembly and oil tank accessory	Ⓑ	51
图 29 Fig.29	充液及滤油油路 Accumulator loading and filter oil pipe	Ⓐ 、 Ⓑ	53
图 30 Fig.30	蓄能器及制动系统 Accumulator and braking system	Ⓐ 、 Ⓑ	55
图 31 Fig.31	驱动桥及冷却油路 Drive axle and cooling system oil pipe	Ⓐ 、 Ⓑ	59
图 32 Fig.32	油泵总成 Pump assembly	Ⓐ 、 Ⓑ	62
图 33 Fig.33	多路阀 Control valve	Ⓐ 、 Ⓑ	65
图 34 Fig.34	先导油源油路 Pilot supply oil pipe	Ⓐ 、 Ⓑ	68
图 35 Fig.35	多路阀操纵系统 Control valve control system	Ⓐ 、 Ⓑ	70
图 36 Fig.36	倾斜管路 Tilting oil pipe	Ⓐ 、 Ⓑ	72
图 37 Fig.37	转向油路 Steering oil pipe	Ⓐ 、 Ⓑ	74

图 38 Fig.38	起升油路 Lifting oil pipe	Ⓐ 、 Ⓑ	76
序号 Item	名 称 Description	适用车型 Series No.	页 码 Page
图 39 Fig.39	油箱附件 Oil tank accessory	Ⓐ 、 Ⓑ	77
图 40 Fig.40	电气系统 Electrical system	Ⓐ	79
图 41 Fig.41	电气系统 Electrical system	Ⓑ	83
图 42 Fig.42	驾驶室 Cab	Ⓐ 、 Ⓑ	87
图 43 Fig.43	驾驶室翻转油路 Cab overturn oil pipe	Ⓐ 、 Ⓑ	89
图 44 Fig.44	驾驶室翻转油缸 Cab overturn cylinder	Ⓐ 、 Ⓑ	91
图 45 Fig.45	起升组件 Lifting part	2 级门架 SIMPLEX 16t	92
图 46 Fig.46	外门架 Outside mast	2 级门架 SIMPLEX 16t	94
图 47 Fig.47	内门架 Inside mast	2 级门架 SIMPLEX 16t	95
图 48-1 Fig.48-1	调距油路 (一) oil pipe system (I)	2 级门架 SIMPLEX 16t	97
图 48-2 Fig.48-2	调距油路 (二) oil pipe system (II)	2 级门架 SIMPLEX 16t	99
图 49 Fig.49	右升降油缸 / 左升降油缸 Lift cylinder ,right/ Lift cylinder,left	2 级门架 SIMPLEX 16t	101
图 50 Fig.50	倾斜油缸 Tilting cylinder	2 级门架 SIMPLEX 16t	103
图 51 Fig.51	主油路系统 Mast piping	2 级门架 SIMPLEX 16t	105
图 52 Fig.52	货叉架 fork shelf	2 级门架 SIMPLEX 16t	107
图 53 Fig.53	调距油缸 Adjusting cylinder	2 级门架 SIMPLEX 16t	110
图 54 Fig.54	链条 Chain	2 级门架 SIMPLEX 16t	112
	可选零件 Optional Parts	Ⓐ 、 Ⓑ	113

图1 标示
Fig.1 Nameplate

Ⓐ CPCD160-W2 Ⓑ CPCD160-W25



图 1 标示
Fig.1 Nameplate

Ⓐ CPCD160-W2 Ⓑ CPCD160-W25

序号 Item No.	代号 Part No.	名称 Description	数量 Q'ty	备注或适 用车型 Remarks or Series No	物料码 Code No.
1	R960-020018-000	起吊标签 Lift nameplate	4		
2	G160-020002-000	载荷曲线标牌 Load nameplate	1		
3	G160-020002-001	载荷曲线标牌 Load nameplate	1		
4	50DH-010005	危险标签 Dangerous nameplate	1		
5	G160-020008-000	轮胎气压标签 Tyre pressure nameplate	4		
6	G160-020005-000	液压油加油标签 Hydraulic oil filler nameplate	1		
7	N163-020005-000	燃油标签 Fuel nameplate	1		
8	R960-020005-000	燃油标签 Fuel nameplate	1		
9	N163-020016-000	警告标签 Warn nameplate	1		
10	R960-020009-000	警告标签 Warn nameplate	1		
11	G160-020015-W00	标签 Nameplate	2		
12	80DH-020008	警告标签 Warn nameplate	1		
13	G160-020004-000	标签 Nameplate	1		
14	G160-020014-000	发动机检测翻页开关标签 Engine inspect page nameplate	1		
15	G160-020014-001	发动机检测翻页开关标签 Motor inspect page nameplate	1		

图 1 标示
Fig.1 Nameplate

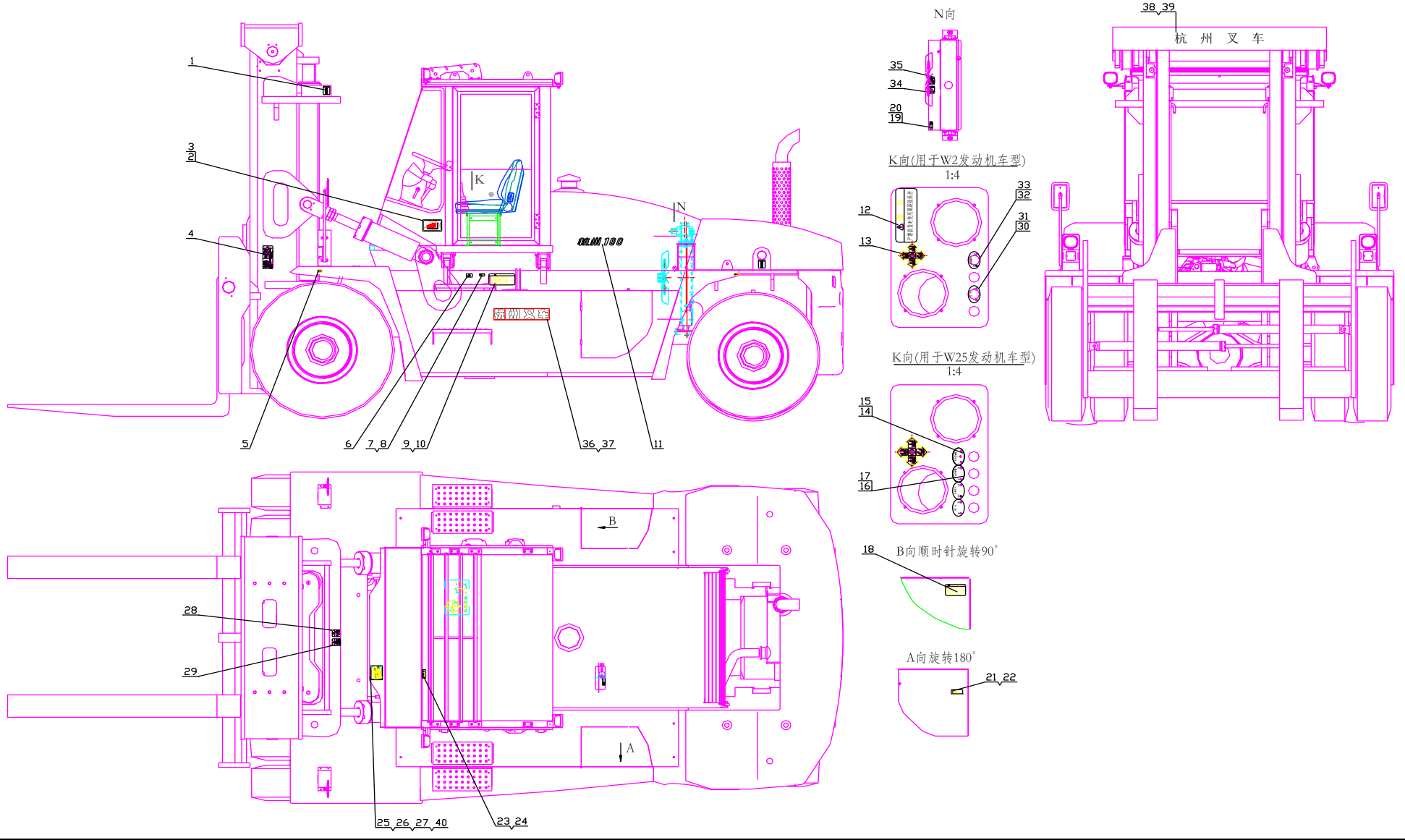
Ⓐ CPCD160-W2 Ⓑ CPCD160-W25

序号 Item No.	代号 Part No.	名称 Description	数量 Q'ty	备注或适 用车型 Remarks or Series No	物料码 Code No.
16	G160-020013-000	发动机检测开关标签 Motor inspect switch nameplate	1		
17	G160-020013-001	发动机检测开关标签 Motor inspect switch nameplate	1		
18	G160-020011-000	驾驶室倾翻操作说明 Cab tilting instruction	1		
19	R960-020016-000	防冻液标签 Anti-icing fluid nameplate	1		
20	R960-020017-000	防冻液标签 Anti-icing fluid nameplate	1		
21	N163-020004-000	保险丝标签 Fuse nameplate	1		
22	R960-020004-000	保险丝标签 Fuse nameplate	1		
23	R960-020007-000	操纵标签 1 Operation nameplate 1	1		
24	N163-020014-000	操纵标签 1 Operation nameplate 1	1		
25	GB12618-90	铆钉 4×10 Rivet 4×10	8		
26	G160-020001-000	产品铭牌 Product nameplate	1		
27	G160-020001-001	产品铭牌 Product nameplate	1		
28	N163-020009-000	危险标签 Dangerous nameplate	1		
29	R960-020015-000	危险标签 Dangerous nameplate	1		
30	G160-020006-000	微动开关标签 Inch switch nameplate	1		

Hangcha 16t Parts Catalogue

Full download: <http://manualplace.com/download/hangcha-16t-parts-catalogue/>

图 1 标示 Fig.1 Nameplate		Ⓐ CPCD160-W2 Ⓑ CPCD160-W25				
序号 Item No.	代号 Part No.	名称 Description	数量 Q'ty	备注或适 用车型 Remarks or Series No	物料码 Code No.	
31	G160-020006-001	微动开关标签 Inch switch nameplate	1			
32	G160-020007-000	换档模式标签 Shift model nameplate	1			
33	G160-020007-001	换档模式标签 Shift model nameplate	1			
34	N163-020020-000	皮带夹手标签 Belt nameplate	1			
35	N163-020019-000	风扇切手标签 Fan ameplate	1			