

# FORD

## LAWN AND GARDEN TRACTOR

# REPAIR MANUAL

**Section**

**1**

**INTRODUCTION**

General	3
Safety	3
Tractor Identification	5
Tractor Specifications	6

# SECTION I INTRODUCTION

## GENERAL

This manual contains service and maintenance for the Ford 10, 12, 14, 16 and 19.5 H.P. tractors.

## MODELS INCLUDED

1. LGT 100 TRACTOR 10 H.P. Gear
2. LGT 120 TRACTOR 12 H.P. Gear
3. LGT 125 TRACTOR 12 H.P. Hydro
4. LGT 145 TRACTOR 14 H.P. Hydro
5. LGT 165 TRACTOR 16 H.P. Hydro
6. LGT 195 TRACTOR 19.5 H.P. Hydro

This manual is divided into sections. Some sections are divided into subsections. The subsections pertain to a certain component or operating system relative to the section title.

All sections of this manual should be carefully studied by the serviceman prior to beginning work on the tractor. In addition to this manual, the operator's manual should also be studied to insure familiarity with all operating procedures and controls.

## SAFETY

 This notation, followed by the word **WARNING**, signifies important precautionary measures which, if not properly followed, could result in personal injury or death.

Read these safety rules and follow them closely. Failure to obey these rules could result in loss of control of machine, severe personal injury or death to yourself or bystanders.



### WARNING

Always store gasoline or flammable solvents used for cleaning in a proper container. Always dispose of used flammable solvent in a proper manner. NEVER discard flammable solvents in a barrel or bin used for ordinary scrap material.



### WARNING

Do not start or run the engine in an enclosed area. Exhaust fumes can kill.



### WARNING

Be certain that engine and exhaust assemblies are not hot before cleaning ANY part of the tractor using a flammable solvent.



### WARNING

Never let shop rags, used for cleaning, lay around to become fire hazards.



### WARNING

Always keep work area clean and free of oil, grease, and water. Some of these may be spilled on the floor during normal disassembly procedures. Clean this up as soon as possible to prevent accidents.



### WARNING

Always disconnect spark plug wire before servicing to prevent accidental starting.



### WARNING

Always wear safety glasses when working in the shop area. Do not confuse ordinary prescription glasses (even with tempered lenses) or sunglasses with shop safety glasses.

 **WARNING**

Be certain that any part being removed is properly supported or held to prevent injury or damage.

 **WARNING**

Be certain that the work bench or support being used is strong enough. The weight of the part plus the force applied to it during assembly or disassembly may put a great strain on the bench or support.

 **WARNING**

If test running is required, read the operator's manual carefully. Be thoroughly familiar with the controls and proper use of the equipment. Know how to stop the unit.

 **WARNING**

Use jack stands or blocks to hold up the unit in any potentially dangerous positions required for access. Do not rely only on a jack for support.

 **WARNING**

Be sure all tools and cleaning materials are removed before starting unit.

 **WARNING**

Be sure all parts are securely fastened before starting the machine.

 **WARNING**

Never operate without guards, plates, or other safety protective devices in place.

 **WARNING**

If the unit should start to vibrate abnormally, stop the engine and check immediately for the cause.

 **WARNING**

Stop engine and disengage PTO whenever you leave the operating platform to make any repairs, adjustments, or inspections.

 **WARNING**

Take all possible precautions when leaving the vehicle unattended. Shift into neutral; set parking brake and stop the engine.

 **WARNING**

When cleaning, repairing, or inspecting, make certain tractor and all moving parts have stopped.

 **WARNING**

Never operate machine at high transport speeds on slippery surfaces. Use care when backing.

 **WARNING**

Disengage PTO when transporting or not in use.

 **WARNING**

Never operate without good visibility or light.

 **WARNING**

Do not put hands or feet near rotating parts.

 **WARNING**

Never store machine with fuel in the fuel tank inside a building where open flame or sparks are present. Allow engine to cool before storing in any enclosure.

**CAUTION**

This symbol identifies procedures or practices that if not followed, could result in mechanical damage leading to personal injury.

**CAUTION**

Always refer to operator's manual for important details if tractor is to be stored for an extended period.

Always be certain that internal components are kept clean and free of chemicals and contaminants.

Always use the proper tool for the work being done. Where a specific tool is specified in the manual, always use THAT tool.

Do not overload machine capacity.

Use only attachments and accessories approved by manufacturers.



**NOTE**

Metric equivalents are included throughout the manual. They are found adjacent to the English measure, eg. 7 gallons (26.5L).

Throughout this manual, reference will be made to, "right hand of tractor, left hand of tractor, etc." This is determined by sitting in the operator's seat facing forward.

**TRACTOR IDENTIFICATION**

**TRACTOR SERIAL NUMBER.** The tractor serial number is located on the tractor frame, *figure 1*, 10, 12, 14, 16 H.P., *figure 2*, 19.5 H.P.

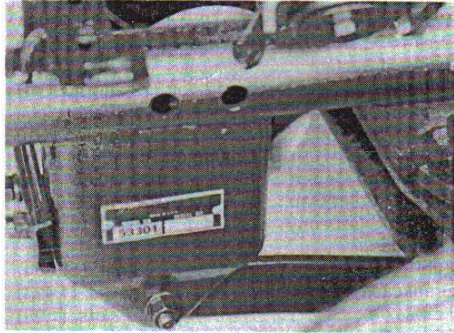

**Figure 1 (10, 12, 14 & 16 H.P.)  
Location of Tractor Serial Number**

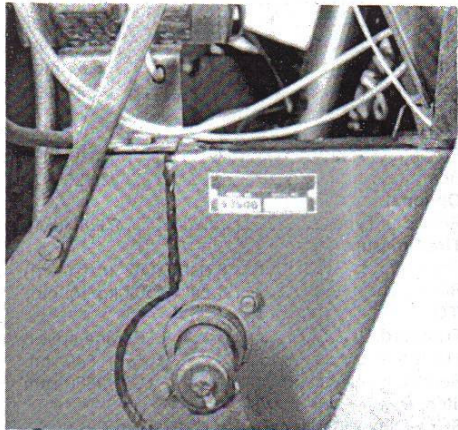

**Figure 2 (19.5 H.P.)  
Location of Tractor Serial Number**

**ENGINE SERIAL NUMBER.** The engine serial number is located on the engine shroud, *figure 3*, 10, 12, 14, 16 H.P. *figure 4*, 19.5 H.P.

**ENGINE SERIAL NUMBER.** The engine serial number is located on the engine shroud, *figure 2*.

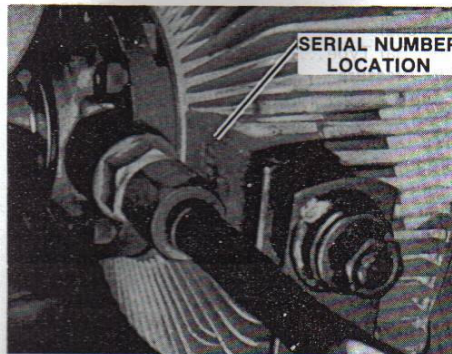

**Figure 3 (10, 12, 14 & 16 H.P.)  
Location of Engine Serial Number**



**Figure 4 (19.5 H.P. Tractor)  
Location of Engine Serial Number**

**TRANSMISSION SERIAL NUMBER.** The transmission serial number is located on the transmission cover, *figure 5*.



**Figure 5 (Typical)  
Location of Transmission Serial Number**









**TORQUE CHART**  
Tolerance  $\pm 10\%$

SIZE	SAE GRADE #2	SAE GRADE #5	SAE GRADE #8
8-32	19 In./Lbs.	30 In./Lbs.	41 In./Lbs.
8-36	20 In./Lbs.	31 In./Lbs.	43 In./Lbs.
10-24	27 In./Lbs.	43 In./Lbs.	60 In./Lbs.
10-32	31 In./Lbs.	49 In./Lbs.	68 In./Lbs.
1/4-20	66 In./Lbs.	8 Ft./Lbs.	12 Ft./Lbs.
1/4-28	76 In./Lbs.	10 Ft./Lbs.	14 Ft./Lbs.
5/16-18	11 Ft./Lbs.	17 Ft./Lbs.	25 Ft./Lbs.
5/16-24	12 Ft./Lbs.	19 Ft./Lbs.	25 Ft./Lbs.
3/8-16	20 Ft./Lbs.	30 Ft./Lbs.	45 Ft./Lbs.
3/8-24	23 Ft./Lbs.	35 Ft./Lbs.	50 Ft./Lbs.
7/16-14	30 Ft./Lbs.	50 Ft./Lbs.	70 Ft./Lbs.
7/16-20	35 Ft./Lbs.	55 Ft./Lbs.	80 Ft./Lbs.
1/2-13	50 Ft./Lbs.	75 Ft./Lbs.	110 Ft./Lbs.
1/2-20	55 Ft./Lbs.	90 Ft./Lbs.	120 Ft./Lbs.
9/16-18	65 Ft./Lbs.	110 Ft./Lbs.	150 Ft./Lbs.
9/16-20	75 Ft./Lbs.	120 Ft./Lbs.	170 Ft./Lbs.
5/8-11	90 Ft./Lbs.	150 Ft./Lbs.	220 Ft./Lbs.
5/8-18	100 Ft./Lbs.	180 Ft./Lbs.	240 Ft./Lbs.
3/4-10	160 Ft./Lbs.	260 Ft./Lbs.	386 Ft./Lbs.
3/4-16	180 Ft./Lbs.	300 Ft./Lbs.	420 Ft./Lbs.
7/8-9	140 Ft./Lbs.	400 Ft./Lbs.	600 Ft./Lbs.
7/8-14	155 Ft./Lbs.	440 Ft./Lbs.	660 Ft./Lbs.
1-8	220 Ft./Lbs.	580 Ft./Lbs.	900 Ft./Lbs.
1-12	240 Ft./Lbs.	640 Ft./Lbs.	1,000 Ft./Lbs.

- NOTES: 1. These torque values are to be for all tractor hardware excluding: locknuts, self-tapping screws, thread forming screws, and sheet metal screws.  
2. Unless otherwise noted, all torque values must meet this specification.

BOLT HEAD MARKING

S.A.E. GRADE:

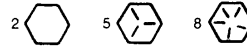

**Standard Tires**

20 x 8.00-10 front tires

6 psi (0.422 kg/sq cm)	400 lbs. (181.4 kg)
8 psi (0.562 kg/sq cm)	470 lbs. (213.2 kg)
10 psi (0.703 kg/sq cm)	535 lbs. (242.7 kg)
12 psi (0.843 kg/sq cm)	595 lbs. (270.0 kg)

29 x 12.00-15 rear tires

5 psi (0.351 kg/sq cm)	790 lbs. (358.3 kg)
10 psi (0.703 kg/sq cm)	1185 lbs. (537.5 kg)
15 psi (1.054 kg/sq cm)	1505 lbs. (682.6 kg)

**Optional Tires**

18 x 8.50 - 8 front tires

6 psi (0.422 kg/sq cm)	380 lbs. (172.4 kg)
8 psi (0.562 kg/sq cm)	450 lbs. (204.1 kg)
10 psi (0.703 kg/sq cm)	515 lbs. (233.6 kg)
12 psi (0.843 kg/sq cm)	570 lbs. (258.5 kg)

26 x 12.00 - 12 rear tires

6 psi (0.422 kg/sq cm)	880 lbs. (399.1 kg)
8 psi (0.562 kg/sq cm)	1040 lbs. (471.7 kg)
10 psi (0.703 kg/sq cm)	1185 lbs. (537.5 kg)
12 psi (0.843 kg/sq cm)	1320 lbs. (598.7 kg)

Maximum load includes weight of tractor, operator, attachments, wheel weights, tire fluid, etc.



**Section** **2**

**LUBRICATION AND  
MAINTENANCE**

Fuel and Lubricant	<b>13</b>
Engine Lubrication	<b>13</b>
Checking Engine Oil	<b>13</b>
Changing Engine Oil	<b>14</b>
Changing Engine Oil Filter	<b>15</b>
Checking Transaxle Fluid	<b>15</b>
Changing Hydraulic Oil Filter	<b>16</b>
Changing Transmission Fluid	<b>16</b>
Chassis Lubrication Charts	<b>17</b>

## SECTION 2 LUBRICATION AND MAINTENANCE

### FUEL AND LUBRICANT

**FUEL.** The engines perform best when the following recommendations are followed:

#### CAUTION

Handle gasoline with care - it is highly flammable. Do not fill fuel tank with engine running or if engine is hot. Do not smoke while filling fuel tank.

Prior to filling fuel tank wipe dirt from around filler neck and fuel tank cap. Dirt allowed to enter the tank may cause hard starting and poor performance. Fill the fuel tank with fresh clean 85 octane (minimum) regular grade gasoline. Leaded or unleaded may be used.

#### CAUTION

DO NOT MIX OIL WITH GASOLINE.

**LUBRICANTS.** Proper use of approved lubricants is the best way of ensuring proper service from the tractor. Use only lubricants specified in this manual and within the intervals specified.

**ENGINE LUBRICATING OIL.** Oils meeting the requirements of the American Petroleum Institute's (API) Service Classification SC, CC, SD, or SE are to be used. Oil viscosity (weight) is selected according to the anticipated ambient temperature. The temperature (viscosity) recommendations are:

Temperature	Oil Viscosity
40°F (4.4 C) & up	SAE 30
0°F (-17, 8 C) to 40°F (4.4 C)	SAE 10W - 30
0°F (-17, 8 C) & below	*SAE 5W - 20

\*Increased oil consumption may be experienced when SAE 5W - 20 oil is used. Check oil more frequently.

**TRANSAXLE** - Non-hydro gear model, SAE 90 oil  
**HYDROSTATIC TRANSMISSION AND TRANS-AXLE.** The following fluids are approved by the manufacturer and are used as factory fills.

1. Texaco Transhydra #2209
2. Ford Motor Co. #M-2C41-A

The following fluids in descending order of preference, are also acceptable.

1. International Harvester Hy Tran
2. Automotive Automatic Transmission fluid type "B".
3. 10W detergent engine oil, no service grade is specified.
4. 20W detergent engine oil, no service grade is specified.

#### CAUTION

Do not mix fluids. Do not use Type "A" Automatic Transmission Fluid. The use of Type "A" and/or intermixing of fluids may cause severe damage to the hydrostatic unit and WILL void the warranty.

**LUBE FITTINGS.** Use a good quality chassis grease.

### ENGINE LUBRICATION

Crankcase (oil change) 10, 12, 14, 16 HP Tractors

Break-in	5 hrs.
Normal Conditions	*30 hrs.

Crankcase (oil change) 19.5 HP Tractor

Break-in	5 hrs.
Normal Conditions	*50 hrs.

Engine Oil Filter 19.5 HP Tractor

Break-in	5 hrs.
Normal Conditions	*100 hrs. (every other oil change)

\*Extreme dusty and dirty conditions require more frequent changes.

### CHECKING ENGINE OIL

Check the oil level using the dipstick located at the side of the engine. For accurate readings, the oil level should be checked approximately 15 minutes after the engine is shut off. Maintain the oil level as near the FULL mark as possible at all times.

To check the oil level of the engine, proceed as follows:

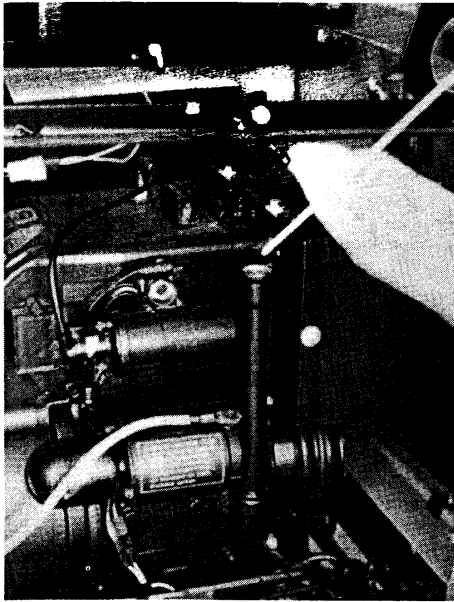

**Figure 1 (10, 12, 14 & 16 H.P.)  
Checking Engine Oil Level**

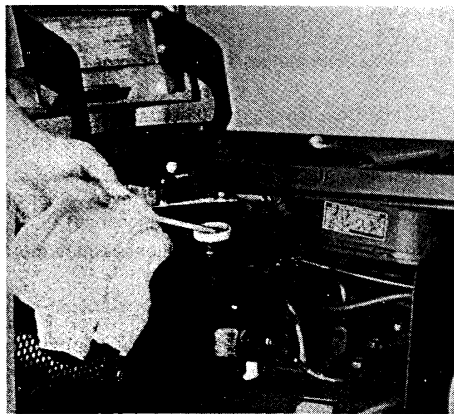

**Figure 2 (19.5 H.P.)  
Checking Engine Oil Level**

1. Park tractor on a level surface, set parking brake, stop engine and raise hood.

- Install dipstick fully prior to taking reading. An inaccurate reading may lead to overfilling and possible engine seal damage.
2. Wipe dust and dirt from around dipstick. Oil must be between marks on dipstick.

### **CHANGING ENGINE OIL**

Engine should be at operating temperature (after engine has run 5 minutes or more) when oil is drained. When hot, the oil will drain faster removing dirt and other foreign material held in suspension.

To change engine oil, proceed as follows:

1. Park tractor on a level surface, set parking brake, stop engine and raise hood.
2. Remove dipstick, *figure 1* 10, 12, 14 & 16 H.P., *figure 2* 19.5 H.P..
3. Remove side panel.
4. Remove drain plug located at front of engine, *figure 3* 10, 12, 14 & 16 H.P., *figure 4* 19.5 H.P.
5. Drain oil into a suitable container. Replace plug after all oil is drained out.

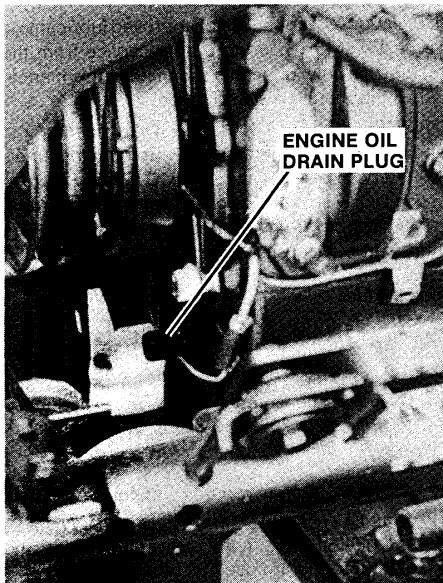

**Figure 3 (10, 12, 14 & 16 H.P.)  
Engine Oil Drain Plug Location**

- Fill crankcase through dipstick opening with oil of the correct viscosity and grade. Fill until oil level is within safe range on dipstick (see Engine Crankcase Capacity Chart below).

#### ENGINE CRANKCASE CAPACITY

Engine HorsePower	Without Filter	With Filter
10	1½ qts. (1.42 l.)	NA
12	1½ qts. (1.42 l.)	NA
14	1½ qts. (1.42 l.)	NA
16	1½ qts. (1.42 l.)	NA
19.5	3 qts. (2.8 l.)	3½ qts. (3.3 l.)

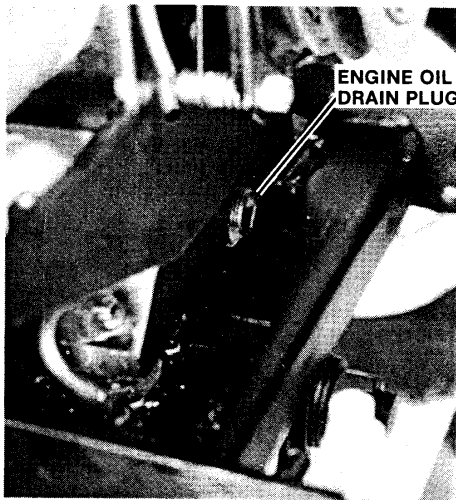

Figure 4 (19.5 H.P.)  
Engine Oil Drain Plug Location

#### CHANGING ENGINE OIL FILTER (19.5 H.P. Tractor Only)

The engine oil filter change interval should be every 100 hours or every other engine oil change at 50 hour intervals.

To change the oil filter, proceed as follows:

- Drain engine crankcase oil ( see Changing Engine Oil, page 14).
- Remove R.H. side panel, *figure 5*.
- Remove filter by turning it counterclockwise. Discard old filter.

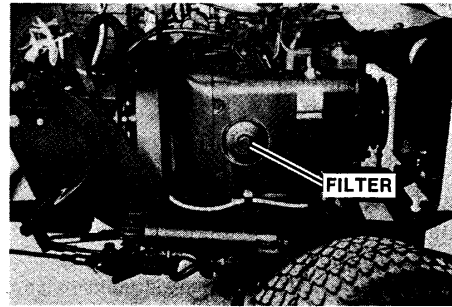

Figure 5 (19.5 H.P.)  
Engine Oil Filter Location

- Clean filter adapter and wipe up any oil spilled on crankcase.
- Lightly grease seal of new filter. Install new filter.

#### NOTE

Do not over tighten, seal may be damaged and future removal extremely difficult.

- Replace drain plug and fill crankcase with oil (see Changing Engine Oil, page 14).

#### CHECKING TRANSAXLE FLUID

The fluid level of the transmission should be checked only when the fluid is **COLD**. It should be checked prior to initial start and maintained with checks at eight hour intervals. With the tractor level, check the transaxle fluid as follows:

##### HYDROSTATIC MODELS

- Check oil level by removing plug A, *figure 6*.

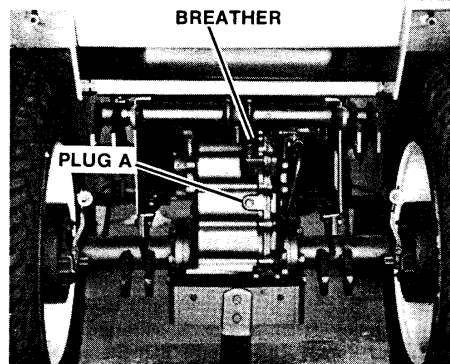

Figure 6 (Hydrostatic Models)  
Checking Fluid Level In Transaxle



When fluid is at the proper level it will begin to dribble out. If fluid is required, remove breather, *figure 6*, and plug A. Add fluid through breather hole until fluid begins to dribble out through hole from plug A. Use Texaco Transhydragal #2209 or Ford Motor Co. #M-2C41-A.

**NOTE**

Do not overfill.

2. Replace plug A and breather.

**GEAR MODELS**

1. Check oil level by removing plug A. When oil is at proper level it will be even with bottom edge of this hole. If oil is required, add SAE-90 oil until proper level is met. Use a pump or funnel with a flexible spout to add oil.
2. Replace plug A.

**CHANGING HYDRAULIC OIL FILTER (Hydrostatic Models Only)**

The hydraulic oil filter change interval should be every 100 hours. The filter is located on the hydrostatic transmission beneath the tractor.

To change hydraulic oil filter, proceed as follows:

1. Park tractor on a level surface, set parking brake and stop engine.
2. Remove and discard old filter.
3. Fill new filter with fresh fluid prior to installation.
4. Install new filter.
5. Check transmission fluid level (Refer to Checking Transmission Fluid Level, page 15) and add fluid as required.

**CHANGING TRANSMISSION FLUID**

1. Park tractor on a level surface; set parking brake and stop engine.

**HYDROSTATIC MODELS**

2. Remove breather, *figure 6*.
3. Remove drain plug, *figure 7*.
4. Drain fluid into a container.
5. Replace drain plug.
6. Remove plug A, *figure 6*.
7. Fill with 4 quarts (3.8 l), (6 quarts for 19.5 H.P.) of Texaco Transhydragal #2209 or Ford Motor Co. #M-2C41-A.
8. Replace plug A and breather, start engine.

**NOTE**

Keep tractor in neutral and operate hydraulic lift (if tractor is so equipped) several times. This insures that the entire system is filled. Run engine approximately 1 minute.

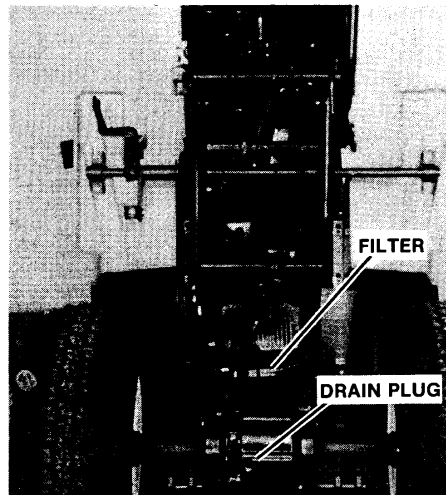

**Figure 7 Underside View (10, 12, 14 & 16 H.P.)**

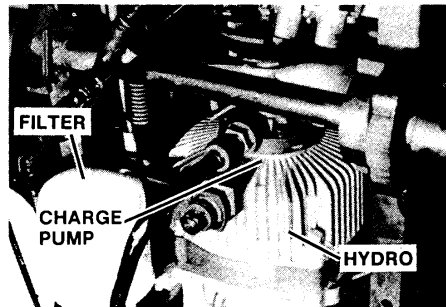

**Figure 8 Underside View (19.5 H.P.)**

9. Stop engine and recheck fluid level. Add fluid as required to bring up to proper level. Refer to Checking Transmission Fluid Level, page 15.

**GEAR MODELS**

1. Remove plug A.
2. Remove drain plug.
3. Drain oil into a container.
4. Replace drain plug.
5. Fill with 2 quarts (1.9 l) SAE 90 oil. Refer to Checking Transmission Fluid Level, page 15.
6. Replace plug A.

R.H. SIDE VIEW

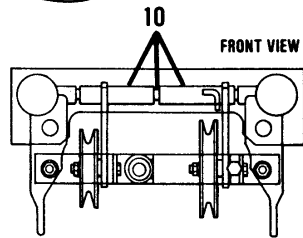
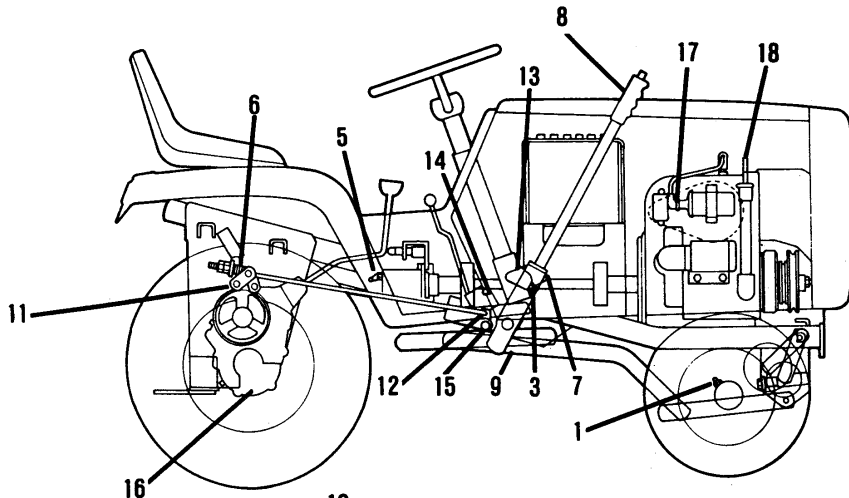

TOP VIEW

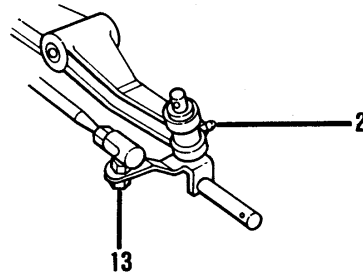
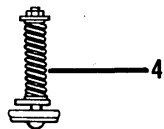

**LUBRICATION CHART  
10 & 12 H.P. GEAR TRACTOR**

REF.	PART NAME	LUBRICANT	LUBRICATION INTERVAL		REMARKS
			30 HOURS	60 HOURS	
1	Grease Fittings (2) Front Wheels	Chassis Grease	●		Fill slowly with grease gun until grease begins to seep out
2	Grease Fittings (2) Each End of Front Axle	Chassis Grease	●		Fill slowly with grease gun until grease begins to seep out
3	Grease Fitting (1) Steering Gear	SAE 90 Oil	●		Fill slowly with grease gun until grease begins to seep out
4	Front Power Take-Off	Chassis Grease	●		Apply around tension springs
5	Grease Fitting (1) Right Angle Gear Box	Chassis Grease	●		Fill slowly with grease gun until grease begins to seep out
6	Brake Adjusting Spring	Chassis Grease	●		Apply around spring
7	Lift Quadrant	Chassis Grease	●		Apply generously
8	Implement Lift Handle	SAE 30 Oil	●		Spring and rod inside handle
9	Implement Lift Linkage	SAE 30 Oil		●	All sliding surfaces, slotted holes and pivot points
10	Idler and Spring Tension Arms and Pivot Rod	SAE 30 Oil		●	All connection points
11	Brake Links and Pins	SAE 30 Oil		●	Caution - do not get oil between brake drum and brake band
12	Brake Rod Pivot	SAE 30 Oil		●	Linkage pivot points
13	Steering Linkage	SAE 30 Oil		●	Outboard bearing and linkage pivot points
14	Parking Brake Lock	SAE 30 Oil		●	Linkage pivot points
15	Clutch and Brake Pivot Shaft	SAE 30 Oil		●	Linkage pivot points
16	4-Speed Transaxle	SAE 90 Oil	●		Fill to required level
17	Engine Air Filter Dry Type			●	Remove element after 60 hours and tap lightly on flat surface to remove loose dirt. Replace after 120 hours (more frequently under extremely dirty or dusty conditions).
18	Engine Crankcase Oil Change	Per Mfg. Rec.	●		See operators manual

Lubricate your tractor on a definite schedule. The rear axle bearings are prepacked and sealed at the factory and need no further lubrication. Apply a few drops of SAE 30 Oil as required to other moving parts not listed above.

**Lubricant:**  
SAE 30 Oil

**Sources:** Sunray DX; Mobil Oil

Chassis Grease - Pressure Gun Grease  
**Sources:** Sunray DX #671; Gulf Supreme #0

SAE 90 Oil

**Sources:** Elco Gear Safety; Exxon Gear Oil "LC"; Mobil Mobilube "46"; Texaco Gear Lube "HD-90".

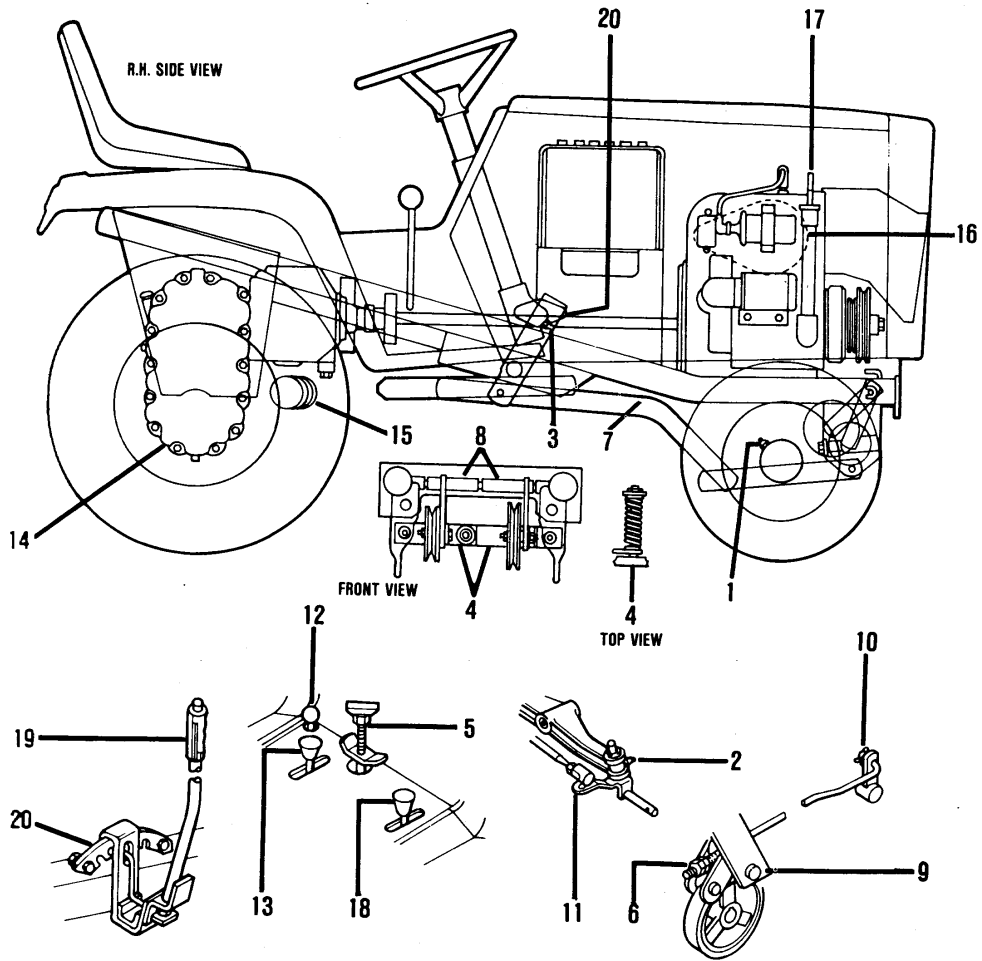

**LUBRICATION CHART**  
**12, 14 & 16 H.P. HYDRO TRACTOR**

REF.	PART NAME	LUBRICANT	LUBRICATION INTERVAL		REMARKS
			30 HOURS	60 HOURS	
1	Grease Fittings (2) Front Wheels	Chassis Grease	●		Fill slowly with grease gun until grease begins to seep out
2	Grease Fittings (2) Each end of front axle	Chassis Grease	●		Fill slowly with grease gun until grease begins to seep out
3	Grease Fitting (1) Steering Gear	SAE 90 Oil	●		Fill slowly with grease gun until grease begins to seep out
4	Front Power Take-Off	Chassis Grease	●		Apply around tension springs
5	Depth Control	Chassis Grease	●		Apply full length of threads
6	Brake Adjusting Spring and Pivot Points	Chassis Grease	●		
7	Implement Lift Linkage	SAE 30 Oil		●	All sliding surfaces, slotted holes and pivot points
8	Idler and Spring Tension Arms	SAE 30 Oil		●	All connection points
9	Brake Links and Pins	SAE 30 Oil		●	Caution - Do not get oil between brake drum and brake band
10	Brake Rod Pivot	SAE 30 Oil		●	Linkage pivot points
11	Steering Linkage	SAE 30 Oil		●	Outboard bearing and linkage pivot points
12	Parking Brake Lock	SAE 30 Oil		●	Linkage pivot points
13	Hydraulic Lift Lever	SAE 30 Oil		●	Linkage pivot points
14	Hydrostatic Transmission	Hydraulic Oil	●		Check Daily
15	Oil Filter (Hydrostatic Transmission)				Change after first 10 hours of operation. No further changes necessary unless system becomes contaminated through oil level checks, refill, or teardown.
16	Engine Air Filter Dry Type			●	Remove element after 60 hours and tap lightly on flat surface to remove loose dirt. Replace after 120 hours (more frequently under extremely dirty or dusty conditions).
17	Engine Crankcase Oil Change	Per Mfg. Rec.	●		See operators manual
18	Speed Range Lever	SAE 30 Oil	●		Linkage pivot points
19	Implement Lift Handle (12 H.P. Model Only)	SAE 30 Oil	●		Spring and rod inside handle
20	Quadrant (12 H.P. Model Only)	Chassis Grease	●		Apply generously

Lubricate your tractor on a definite schedule. The rear axle bearings are prepacked and sealed at the factory and need no further lubrication. Apply a few drops of SAE 30 Oil as required to other moving parts not listed above.

**Lubricant:**  
SAE 30 Oil.

**Sources:** Sunray DX; Mobil Oil

Chassis Grease - Pressure Gun Grease  
**Sources:** Sunray DX #671; Gulf Supreme #0

Hydraulic Oil, **Sources:** Texaco Transhydraulic #2209, Ford Motor Co. #M-2041-A, Texaco Torque Fluid C3 1821 Formulation No. TL-9039.

SAE 90, **Sources:** Elco Gear Safety; Exxon Gear Oil "LC"; Mobil Mobilube "46"; Texaco Gear Lube "HD-90".

