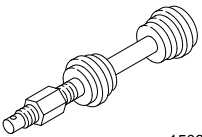
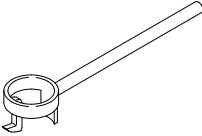
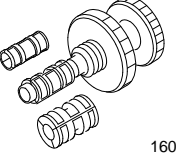
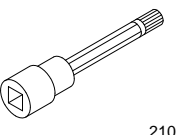
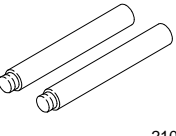
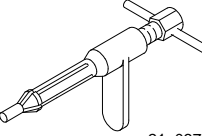
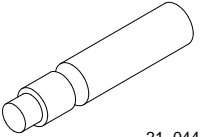
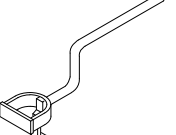
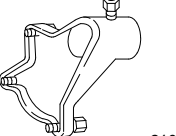
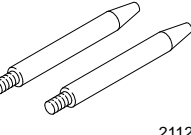
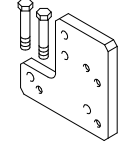
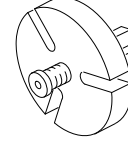
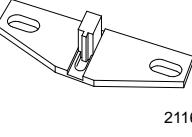
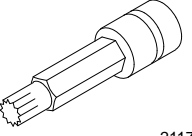
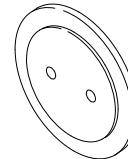
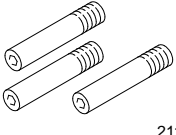
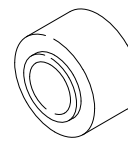
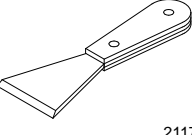
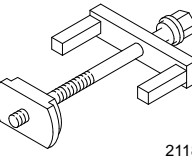
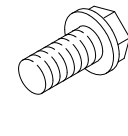
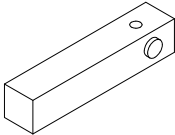
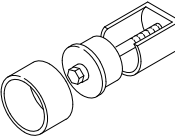
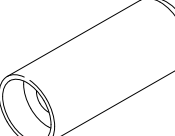
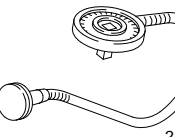
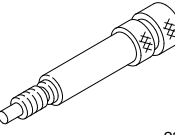
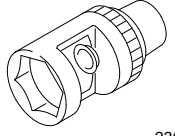
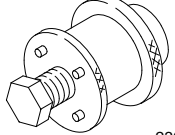
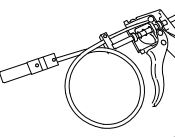
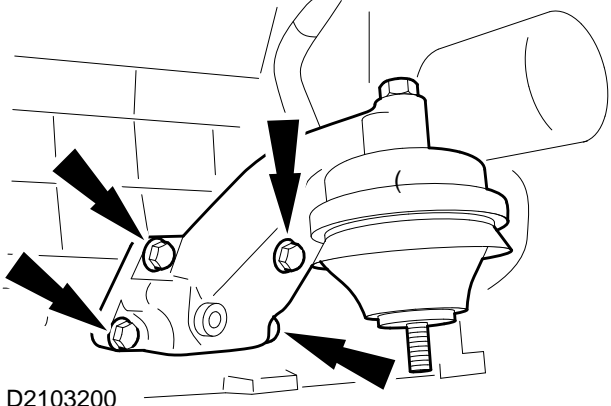

Engine – Dismantle and Assemble (21 134 8)

Special Tools

 15033	15-033 Remover/installer, crankshaft main bearing
 15072	15-072 Oil seal remover
 16067	16-067 Locator for clutch disc
 21002	21-002 Splined head socket, cylinder head bolts
 21003	21-003 Cylinder head locating studs
 21-037 B	21-037 B Pilot bearing remover
 21-044 A	21-044A Installer/aligner, pilot bearing/clutch plate
 21051	21-051 Oil seal remover
 21064	21-064 Mounting bracket
 21128	21-128 Cylinder head guide studs

 21150A	21-150A Mounting plate
 21153B	21-153B Remover for vibration damper
 21168	21-168 Crankshaft immobilising tool
 21175	21-175 Wrench for M14 cylinder head bolts
 21176	21-176 Installer, radial oil seal
 21177	21-177 Flywheel locating studs
 21178	21-178 Installer, radial oil seal
 21179	21-179 Separator, sump
 21181	21-181 Remover, cylinder liner
 21182	21-182 Cylinder liner clamping bolts

 21183	21-183 Measuring fixture, cylinder liner protrusion
 21185	21-185 Remover/installer, crankshaft main bearing
 21186	21-186 Crankshaft guide sleeve
 21540	21-540 Bolt tightening angle gauge
 23018	23-018 Dial indicator fixture for fuel injection pump timing
 23043	23-043 Wrench for injectors
 23044	23-044 Remover, injection pump timing pulley
 24003	24-003 Remover/installer, cooling hose clamp
 D2103200	

Proprietary Tools

Oil filter wrench
Dial indicators
Magnetic fixture
Internal gauge
Micrometer screw 50 – 75 mm
Micrometer screw 75 – 100 mm
Piston ring compressor
T30 bit with 1/4" bit holder and extension

Workshop Equipment

Assembly stand	
Workshop press	

Materials

Plastigage	Obtainable through: Replacement Services Limited, 30 Euston Street, Freemans Industrial Estate, Leicester, LE2 7ST
Copper oil seals for injectors: 1,5 mm thick, with an internal diameter of 17,5 mm.	Obtainable through: Bosch authorised dealerships
Adhesive Loctite 222	WSK-M2G351-A4
Engine Oil	SAE 15W40
Lubricant	Hypoid oil SAE90
Lubricant	ESD-M1C220-A
Sealer	SLM-4G9111-A
Sealer	ESEAM-1C1014
Sealer	SPM-2G9121-A
Adhesive	WSK-M2G349-A7

Dismantle**1. General note.**

Use removal and fitting tool 24-003 to remove coolant and breather hoses if necessary.

2. Remove the left-hand engine mounting bracket.

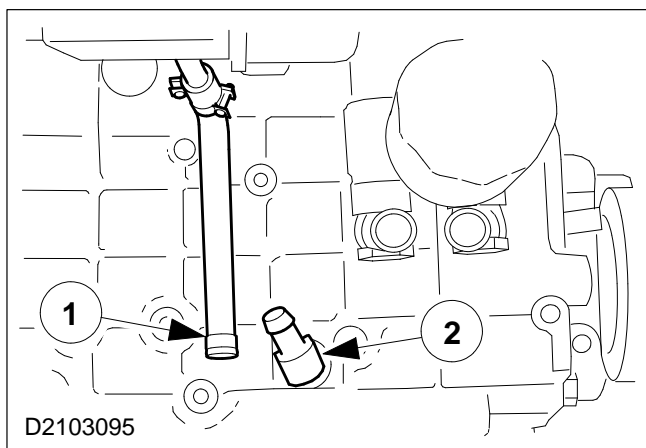

NOTE: Watch out for escaping oil.

3. Detach the turbocharger oil return hose.

- 1 Detach the hose.
- 2 Remove the connector.

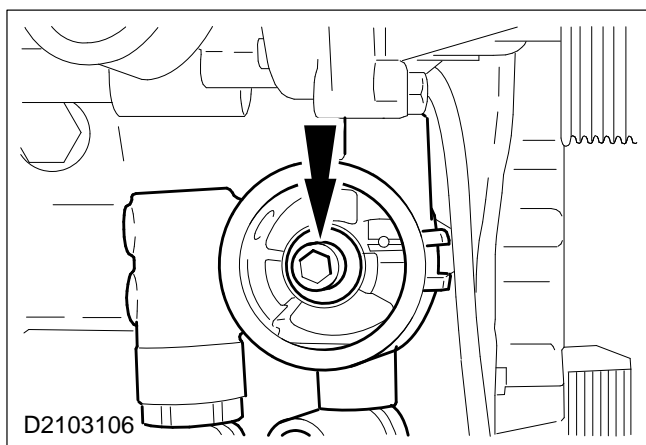

NOTE: Escaping oil.

4. Remove the engine oil filter.

5. Remove the oil filter intermediate housing.

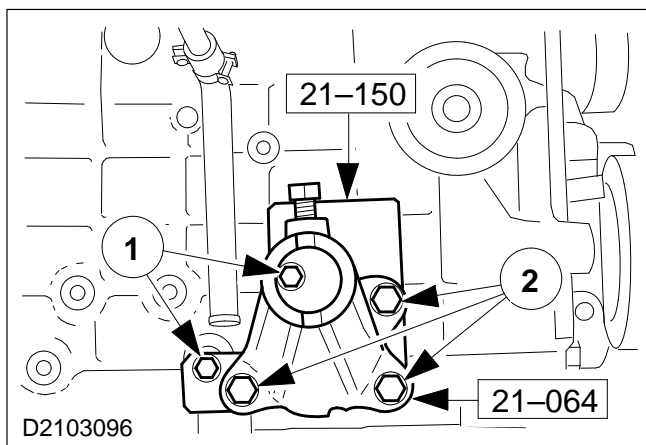

6. Mount the engine on an assembly stand.

- 1 Fit the mounting plate.
- 2 Fit the mounting bracket to the mounting plate.

Mount the engine on the assembly stand

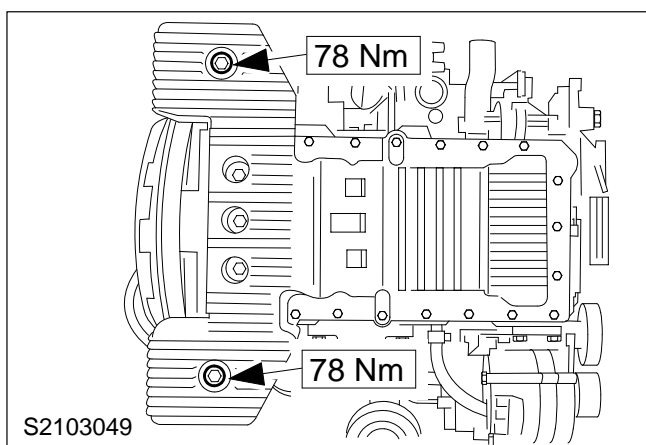

NOTE: Remove both oil drain plugs.

7. Drain off the engine oil.

Tighten the oil drain plugs with new oil seals once the engine oil has been removed.

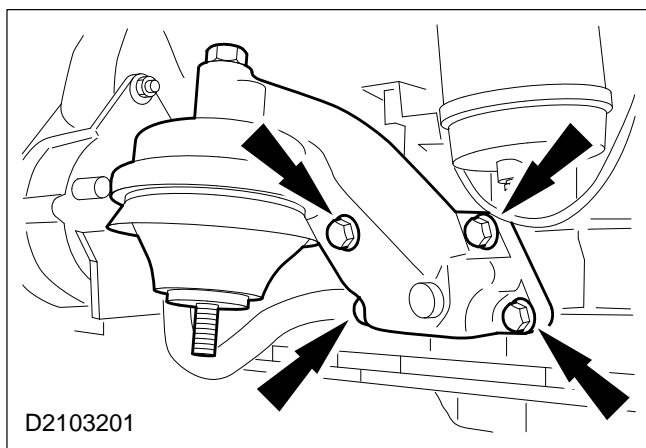

8. Remove the right-hand engine mounting bracket.

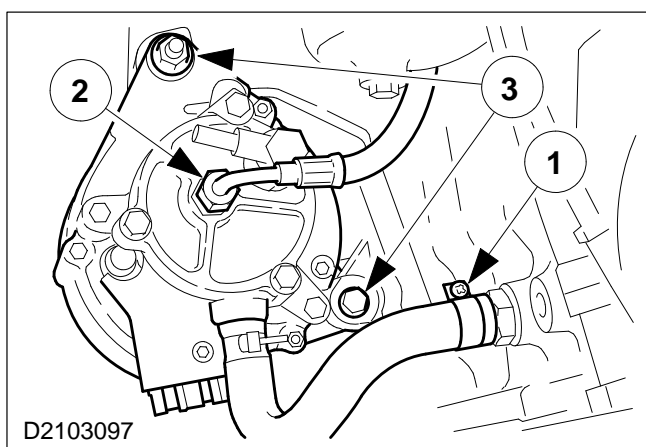

9. Remove the alternator with the vacuum pump.

- 1 Detach the vacuum pump oil return hose.
- 2 Detach the oil feed pipe.
- 3 Remove the alternator and vacuum pump.

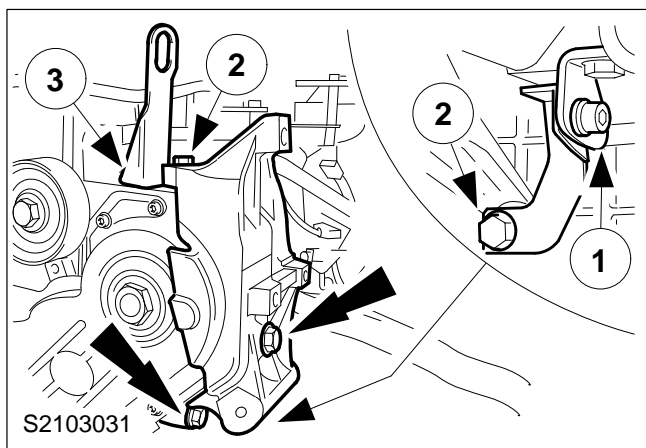

10. Detach the upper alternator bracket and the lower fuel injection pump bracket.

- 1 Undo the nut and bolt on the injection pump bracket.
- 2 Remove the alternator bracket.
- 3 Remove the engine lifting eye (one bolt).

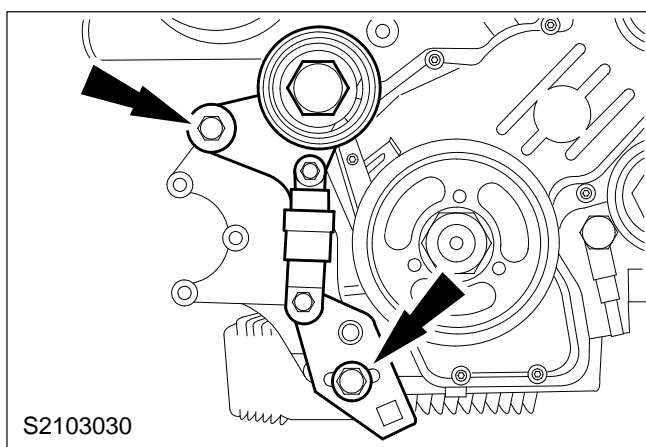

11. Remove the automatic belt tensioner.