

NISSAN 240SX

MODEL S13 SERIES

QUICK REFERENCE INDEX

GENERAL INFORMATION _____	GI
MAINTENANCE _____	MA
ENGINE MECHANICAL _____	EM
ENGINE LUBRICATION & COOLING SYSTEMS —	LC
ENGINE FUEL & EMISSION CONTROL SYSTEM —	EF & EC
ENGINE CONTROL, FUEL & EXHAUST SYSTEM —	FE
CLUTCH _____	CL
MANUAL TRANSMISSION _____	MT
AUTOMATIC TRANSMISSION _____	AT
PROPELLER SHAFT & DIFFERENTIAL CARRIER —	PD
FRONT AXLE & FRONT SUSPENSION _____	FA
REAR AXLE & REAR SUSPENSION _____	RA
BRAKE SYSTEM _____	BR
STEERING SYSTEM _____	ST
BODY _____	BF
HEATER & AIR CONDITIONER _____	HA
ELECTRICAL SYSTEM _____	EL

FOREWORD

This manual contains maintenance and repair procedures for the 1990 Nissan 240SX.

In order to assure your safety and the efficient functioning of the vehicle, this manual should be read thoroughly. It is especially important that the PRECAUTIONS in the GI section be completely understood before starting any repair task.

All information in this manual is based on the latest product information at the time of publication. The right is reserved to make changes in specifications and methods at any time without notice.

IMPORTANT SAFETY NOTICE

The proper performance of service is essential for both the safety of the technician and the efficient functioning of the vehicle.

The service methods in this Service Manual are described in such a manner that the service may be performed safely and accurately.

Service varies with the procedures used, the skills of the technician and the tools and parts available. Accordingly, anyone using service procedures, tools or parts which are not specifically recommended by NISSAN must first completely satisfy himself that neither his safety nor the vehicle's safety will be jeopardized by the service method selected.



NISSAN MOTOR CO., LTD.

Overseas Service Department

Tokyo, Japan

GENERAL INFORMATION

GI

SECTION **GI**

CONTENTS

PRECAUTIONS	GI- 2
HOW TO USE THIS MANUAL	GI- 5
HOW TO READ WIRING DIAGRAMS	GI- 7
HOW TO FOLLOW FLOW CHART IN TROUBLE DIAGNOSES	GI-10
IDENTIFICATION INFORMATION	GI-13
LIFTING POINTS AND TOW TRUCK TOWING	GI-17
TIGHTENING TORQUE OF STANDARD BOLTS	GI-20

PRECAUTIONS

Observe the following precautions to ensure safe and proper servicing. These precautions are not described in each individual section.

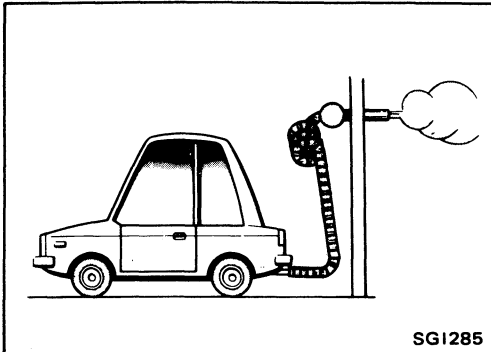

1. Do not operate the engine for an extended period of time without proper exhaust ventilation. Keep the work area well ventilated and free of any inflammable materials. Special care should be taken when handling any inflammable or poisonous materials, such as gasoline, refrigerant gas, etc. When working in a pit or other enclosed area, be sure to properly ventilate the area before working with hazardous materials. Do not smoke while working on the vehicle.

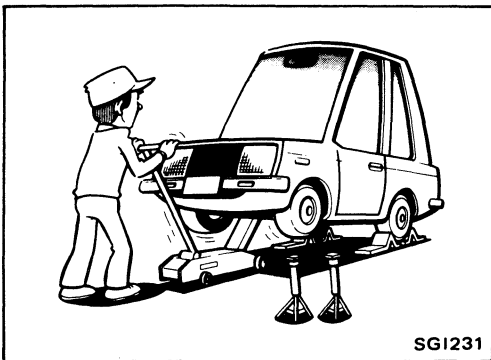

2. Before jacking up the vehicle, apply wheel chocks or other tire blocks to the wheels to prevent the vehicle from moving. After jacking up the vehicle, support the vehicle weight with safety stands at the points designated for proper lifting and towing before working on the vehicle. These operations should be done on a level surface.
3. When removing a heavy component such as the engine or transaxle/transmission, be careful not to lose your balance and drop them. Also, do not allow them to strike adjacent parts, especially the brake tubes and master cylinder.

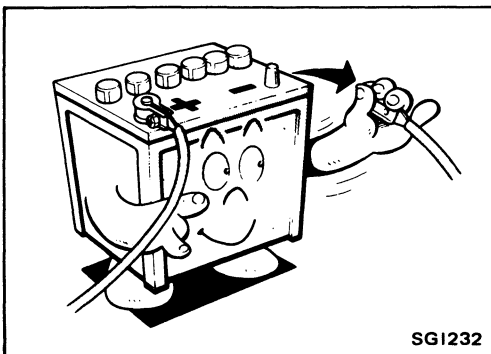

4. Before starting repairs which do not require battery power, always turn off the ignition switch, then disconnect the ground cable from the battery to prevent accidental short circuit.

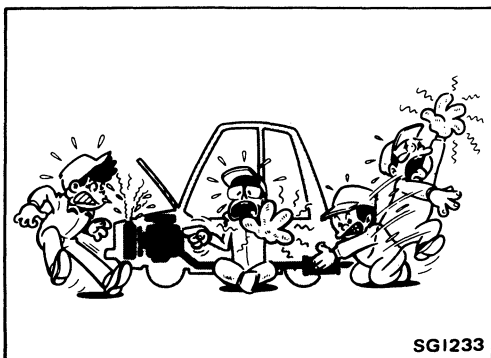

5. To prevent serious burns, avoid contact with hot metal parts such as the radiator, exhaust manifold, tail pipe and muffler. Do not remove the radiator cap when the engine is hot.

PRECAUTIONS

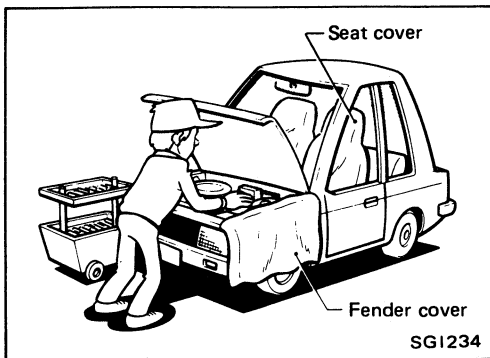

6. Before servicing the vehicle, protect fenders, upholstery and carpeting with appropriate covers. Take caution that keys, buckles or buttons on your person do not scratch the paint.

7. Clean all disassembled parts in the designated liquid or solvent prior to inspection or assembly.
8. Replace oil seals, gaskets, packings, O-rings, locking washers, cotter pins, self-locking nuts, etc. with new ones.
9. Replace inner and outer races of tapered roller bearings and needle bearings as a set.
10. Arrange the disassembled parts in accordance with their assembled locations and sequence.
11. Do not touch the terminals of electrical components which use microcomputers (such as electronic control units). Static electricity may damage internal electronic components.
12. After disconnecting vacuum or air hoses, attach a tag to indicate the proper connection.
13. Use only the lubricants specified in MA section.
14. Use approved bonding agent, sealants or their equivalents when required.
15. Use tools and recommended special tools where specified for safe and efficient service repairs.
16. When repairing the fuel, oil, water, vacuum or exhaust systems, check all affected lines for leaks.
17. Dispose of drained oil or the solvent used for cleaning parts in an appropriate manner.

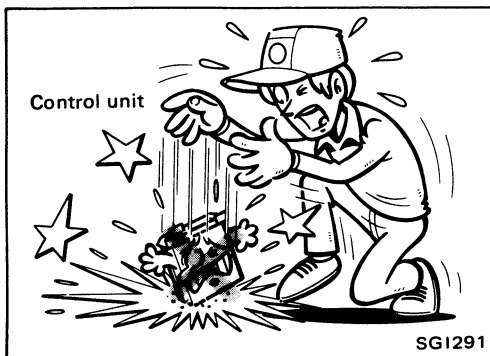

Precautions for E.F.I. or E.C.C.S. Engine

1. Before connecting or disconnecting E.F.I. or E.C.C.S. harness connector to or from any E.F.I. or E.C.C.S. control unit, be sure to turn the ignition switch to the "OFF" position and disconnect the negative battery terminal. Otherwise, there may be damage to control unit.
2. Before disconnecting pressurized fuel line from fuel pump to injectors, be sure to release fuel pressure to eliminate danger.
3. Be careful not to jar components such as control unit and air flow meter.

PRECAUTIONS

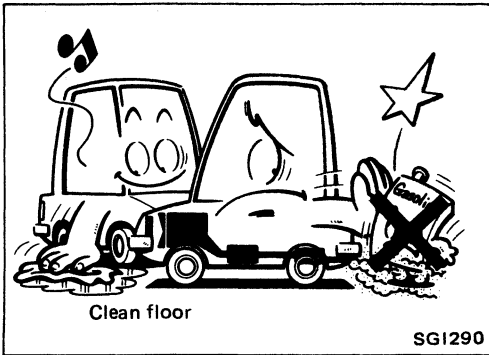

Precautions for Catalyst

If a large amount of unburned fuel flows into the converter, the converter temperature will be excessively high. To prevent this, follow the procedure below:

1. Use unleaded gasoline only. Leaded gasoline will seriously damage the catalytic converter.
2. When checking for ignition spark or measuring engine compression, make tests quickly and only when necessary.
3. Do not run engine when the fuel tank level is low, otherwise the engine may misfire causing damage to the converter.
4. Do not place the vehicle on inflammable material. Keep inflammable material off the exhaust pipe.

Precautions for Fuel

**Unleaded gasoline of
at least 87 AKI number (RON 91)**

HOW TO USE THIS MANUAL

1. **A QUICK REFERENCE INDEX**, a black tab (e.g. **BR**) is provided on the first page. You can quickly find the first page of each section by mating it to the section's black tab.
2. **THE CONTENTS** are listed on the first page of each section.
3. **THE TITLE** is indicated on the upper portion of each page and shows the part or system.
4. **THE PAGE NUMBER** of each section consists of two letters which designate the particular section and a number (e.g. "BR-5").
5. **THE LARGE ILLUSTRATIONS** are exploded views (See below) and contain tightening torques, lubrication points and other information necessary to perform repairs.
The illustrations should be used in reference to service matters only. When ordering parts, refer to the appropriate **PARTS CATALOG**.

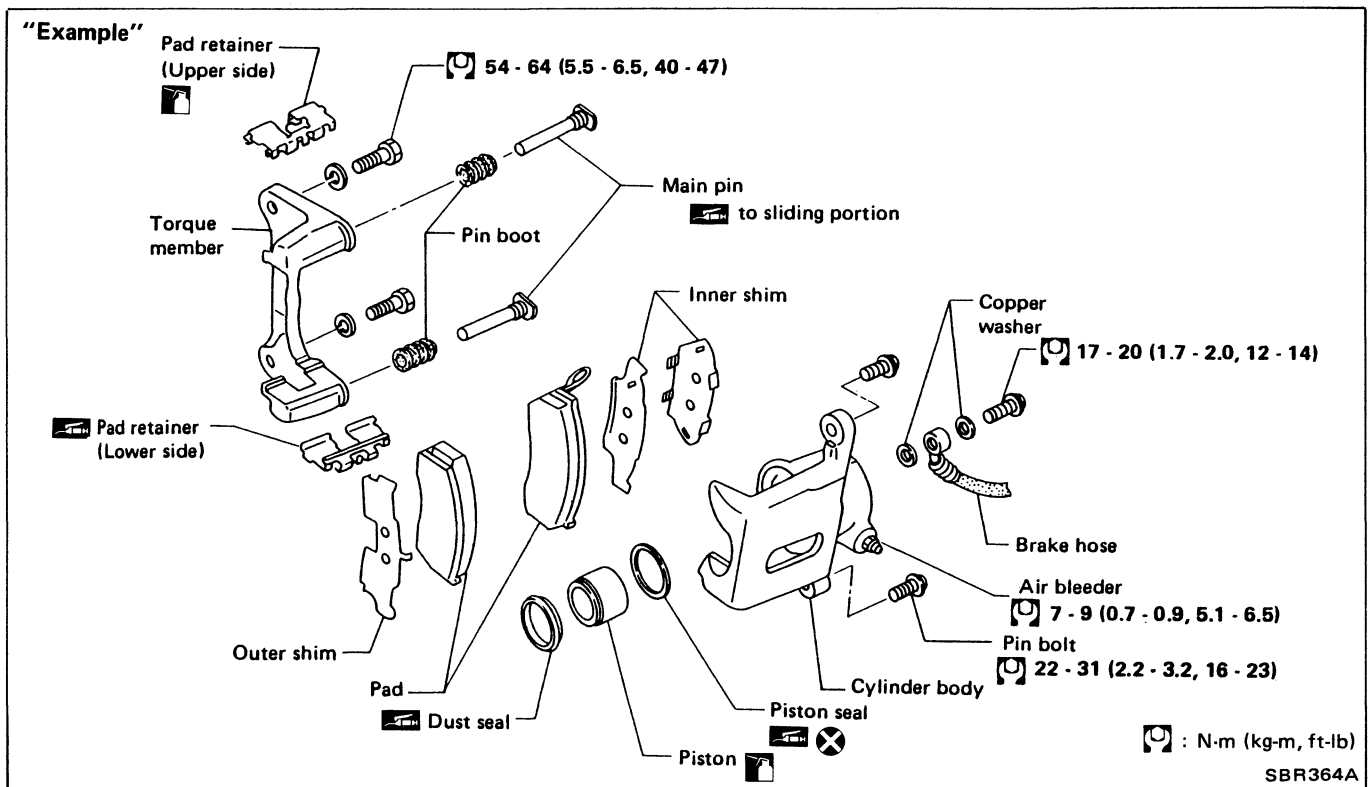

6. **THE SMALL ILLUSTRATIONS** show the important steps such as inspection, use of special tools, knacks of work and hidden or tricky steps which are not shown in the previous large illustrations. Assembly, inspection and adjustment procedures for the complicated units such as the automatic transaxle or transmission, etc. are presented in a step-by-step format where necessary.
7. The following **SYMBOLS AND ABBREVIATIONS** are used:

	: Tightening torque	M/T	: Manual Transaxle/Transmission
	: Should be lubricated with grease. Unless otherwise indicated, use recommended multi-purpose grease.	A/T	: Automatic Transaxle/Transmission
	: Should be lubricated with oil.	Tool	: Special Service Tools
	: Sealing point	L.H.D.	: Left-Hand Drive
	: Checking point	R.H.D.	: Right-Hand Drive
	: Always replace after every disassembly.	A.T.F.	: Automatic Transmission Fluid
	: Apply petroleum jelly.	D ₁	: Drive range 1st gear
	: Apply A.T.F.	D ₂	: Drive range 2nd gear
★	: Select with proper thickness.	D ₃	: Drive range 3rd gear
☆	: Adjustment is required.	D ₄	: Drive range 4th gear
S.D.S.	: Service Data and Specifications	O.D.	: Overdrive
L.H., R.H.	: Left-Hand, Right-Hand	2 ₂	: 2nd range 2nd gear
		2 ₁	: 2nd range 1st gear
		1 ₂	: 1st range 2nd gear
		1 ₁	: 1st range 1st gear

HOW TO USE THIS MANUAL

8. The **UNITS** given in this manual are primarily expressed as the SI UNIT (International System of Unit), and alternatively expressed in the metric system and in the yard/pound system.

“**Example**”

Tightening torque:

59 - 78 N·m (6.0 - 8.0 kg-m, 43 - 58 ft-lb)

9. **TROUBLE DIAGNOSES** are included in sections dealing with complicated components.
10. **SERVICE DATA AND SPECIFICATIONS** are contained at the end of each section for quick reference of data.
11. The captions **WARNING** and **CAUTION** warn you of steps that must be followed to prevent personal injury and/or damage to some part of the vehicle.
- **WARNING** indicates the possibility of personal injury if instructions are not followed.
 - **CAUTION** indicates the possibility of component damage if instructions are not followed.
 - **BOLD TYPED STATEMENTS** except **WARNING** and **CAUTION** give you helpful information.

HOW TO READ WIRING DIAGRAMS

WIRING DIAGRAM

Symbols used in WIRING DIAGRAM are shown below:

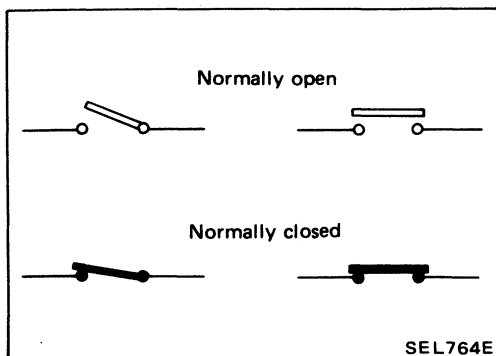
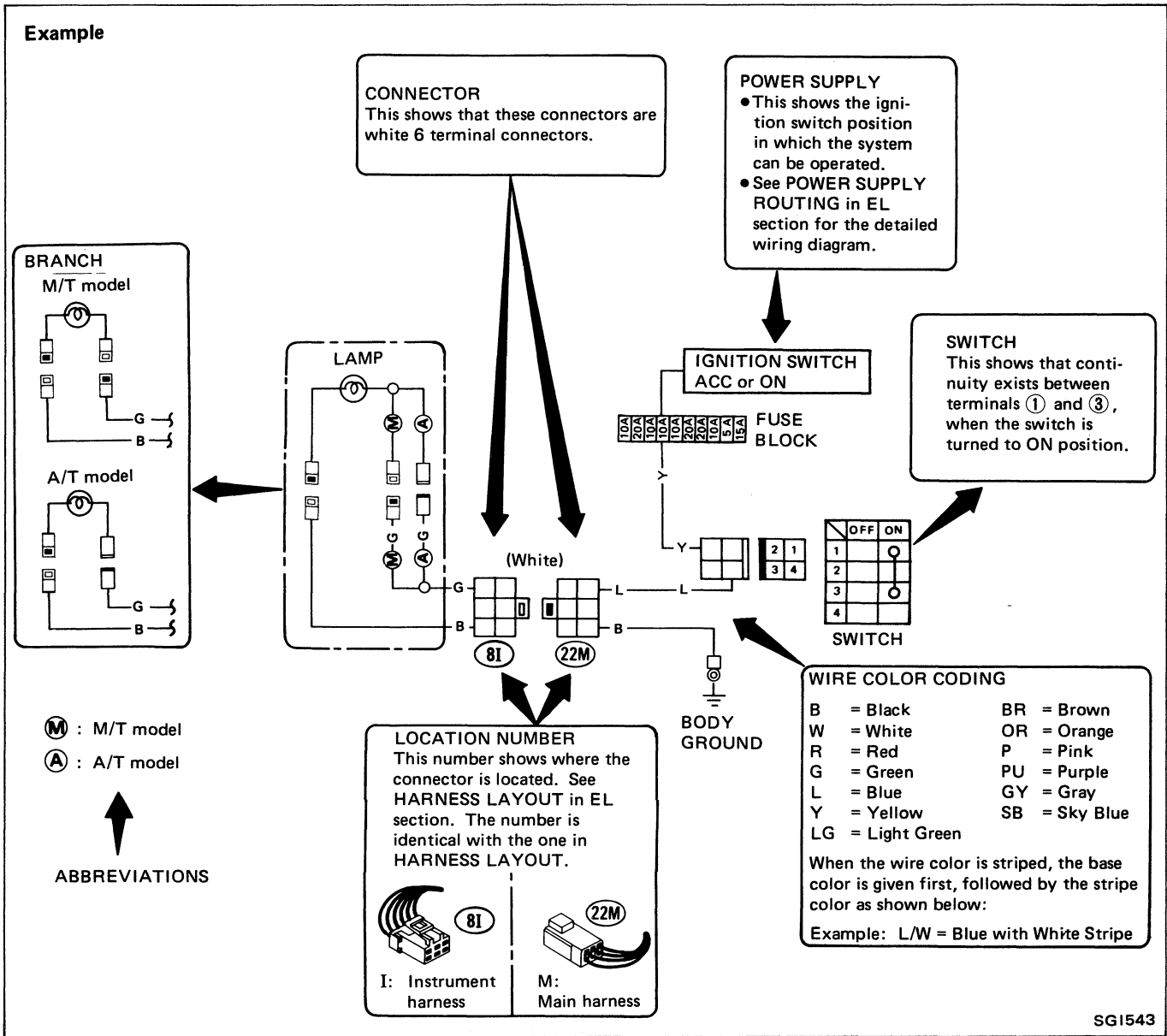

SWITCH POSITIONS

Wiring diagram switches are shown with the vehicle in the following condition.

- Ignition switch "OFF".
- Doors, hood and trunk lid/back door closed.
- Pedals are not depressed and parking brake is released.

HOW TO READ WIRING DIAGRAMS

Example

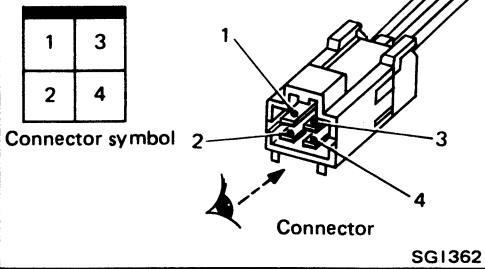

CONNECTOR SYMBOLS

- All connector symbols in wiring diagrams are shown from the terminal side.

Example

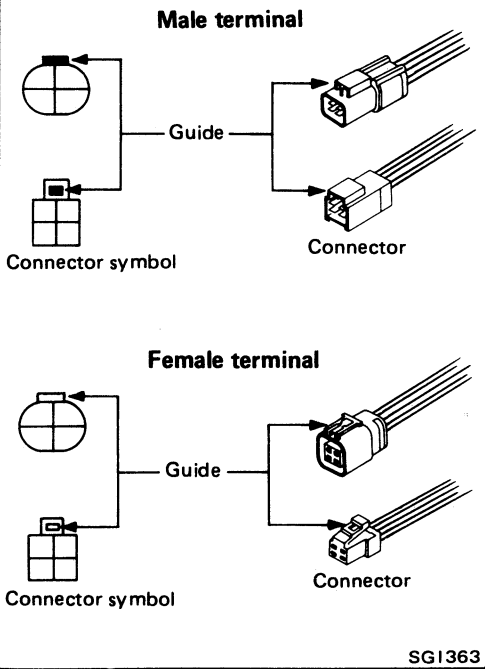

- Male and female terminals
Connector guides for male terminals are shown in black and female terminals in white in wiring diagrams.

MULTIPLE SWITCH

The continuity of the multiple switch is identified in the switch chart in wiring diagrams.

Example

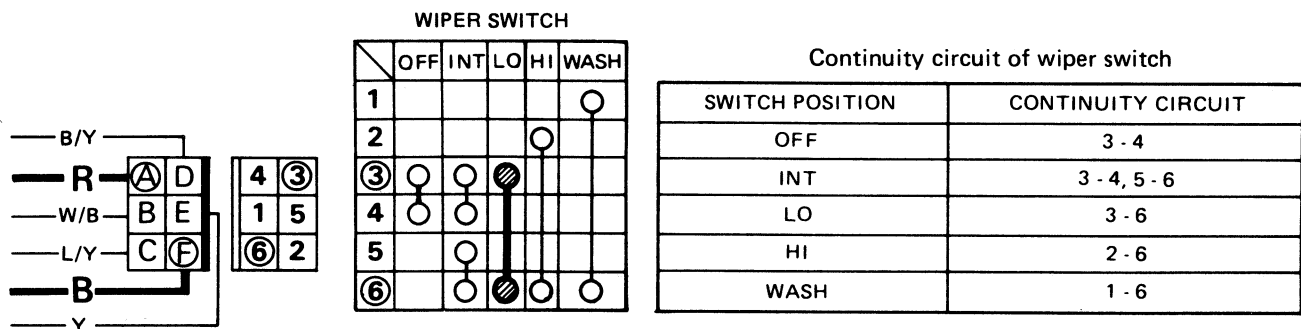

Example: Wiper switch in LO position

Continuity circuit: Red wire - (A) terminal - (③) terminal - Wiper switch (● - ●: LO) - (⑥) terminal - (F) terminal - Black wire

HOW TO READ WIRING DIAGRAMS

SUPER MULTIPLE JUNCTION (S.M.J.)

- The "S.M.J." indicated in wiring diagrams is shown in a simplified form. The terminal arrangement should therefore be referred to in the foldout at the end of the Service Manual.
- The foldout should be spread to read the entire wiring diagram.

Example

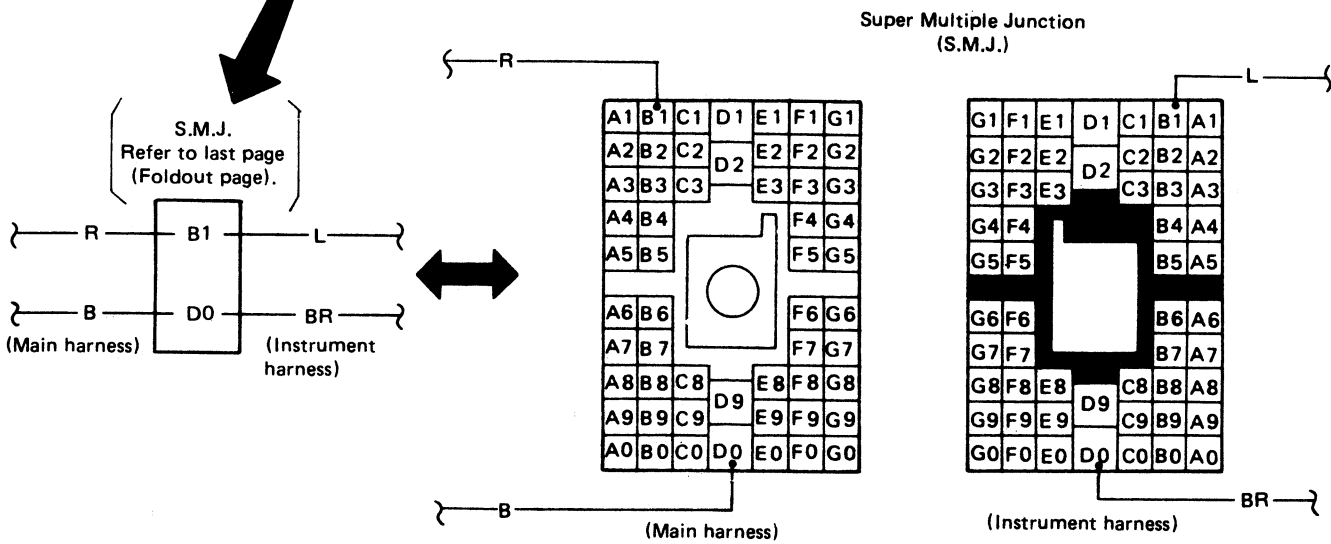
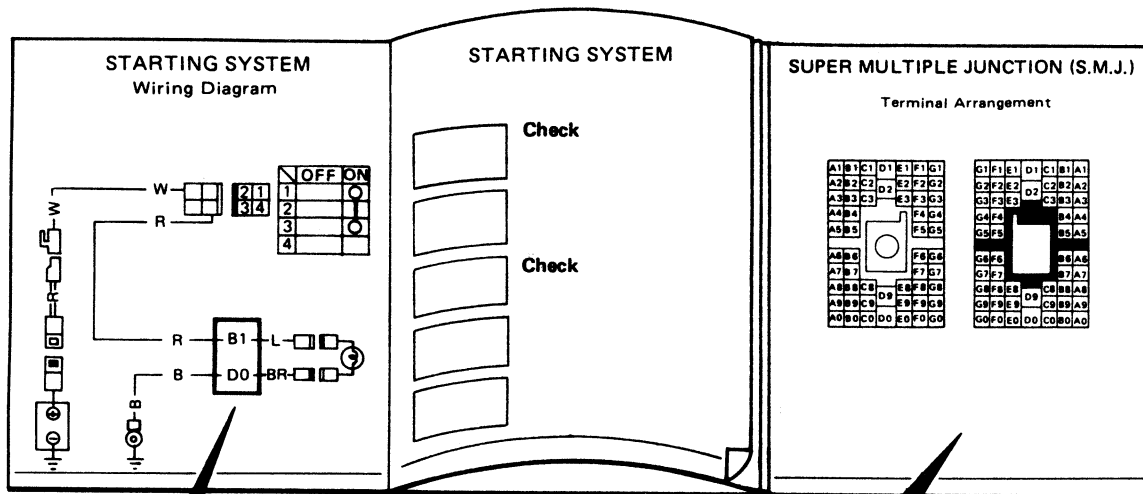

SEL653F

HOW TO FOLLOW FLOW CHART IN TROUBLE DIAGNOSES

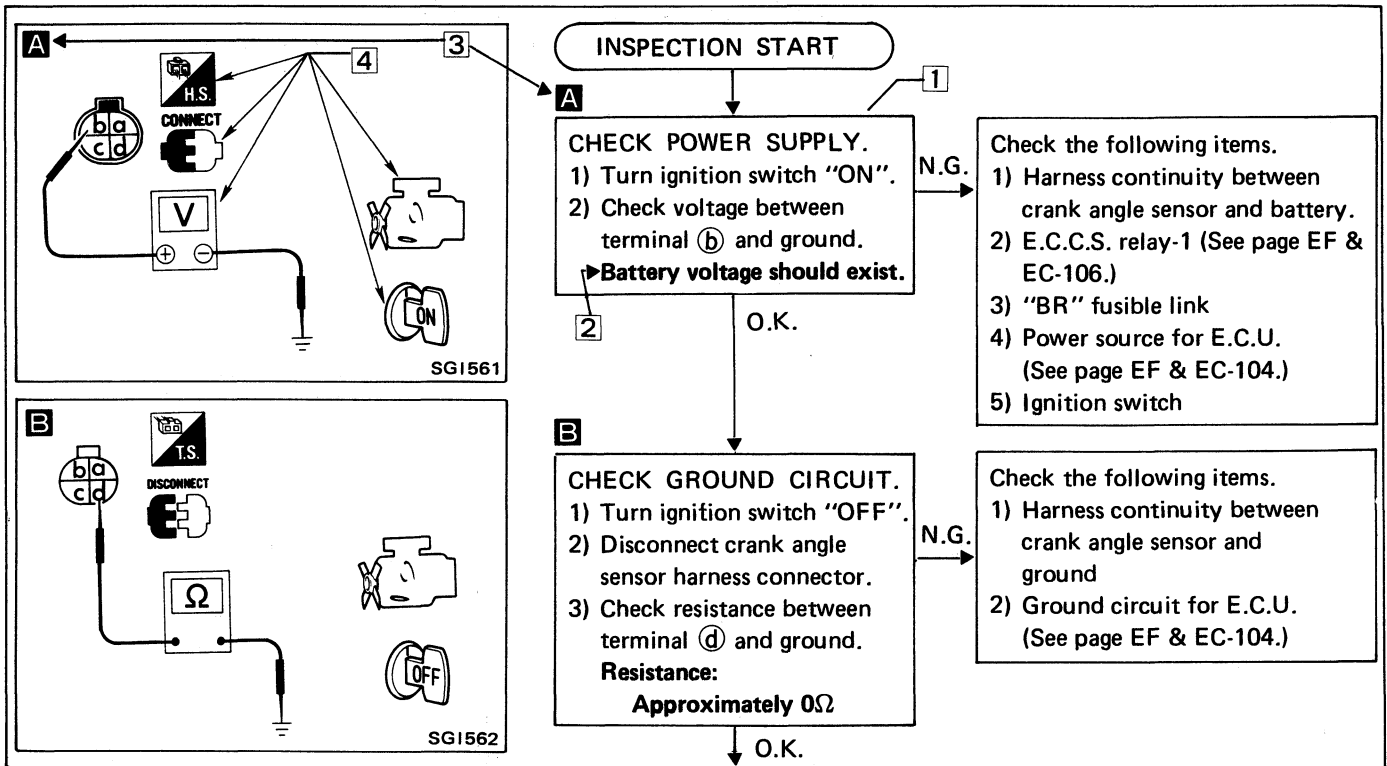

NOTICE

The flow chart indicates work procedures required to diagnose problems effectively. Observe the following instructions before diagnosing.

- 1) Use the flow chart after locating probable causes of a problem following the "Preliminary Check" or the "Symptom Chart".
- 2) After repairs, re-check that the problem has been completely eliminated.
- 3) Refer to Component Parts Location and Harness Layout for the Systems described in each section for identification/location of components and harness connectors.
- 4) Refer to the Circuit Diagram for Quick Pin Point Check. If you must perform circuit continuity between harness connectors more detail, such as in case of sub harness is used, refer to Wiring Diagram and Harness Layout in EL section for identification of harness connectors.
- 5) When checking circuit continuity, ignition switch should be "OFF".
- 6) Before checking voltage at connectors, check battery voltage.
- 7) After accomplishing the Diagnostic Procedures and Electrical Components Inspection, make sure that all harness connectors are reconnected as it was.

HOW TO FOLLOW FLOW CHART IN TROUBLE DIAGNOSES

HOW TO FOLLOW THIS FLOW CHART

1 Work and diagnostic procedure

Start to diagnose a problem using procedures indicated in enclosed blocks, as shown in the following example.

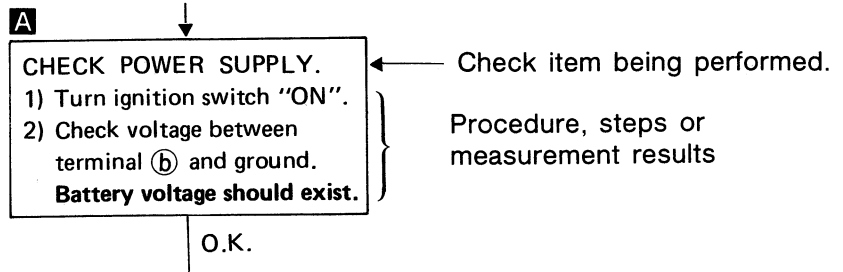

2 Measurement results

Required results are indicated in bold type in the corresponding block, as shown below.

These have the following meanings:

Battery voltage → 11 - 14V or approximately 12V

Voltage: Approximately 0V → Less than 1V

3 Cross reference of work symbols in the text and illustrations

Illustrations are provided as visual aids for work procedures. For example, symbol **A** indicated in the left upper portion of each illustration corresponds with the symbol in the flowchart for easy identification. More precisely, the procedure under the "CHECK POWER SUPPLY" outlined previously is indicated by an illustration **A**.

4 Symbols used in illustrations

Symbols included in illustrations refer to measurements or procedures. Before diagnosing a problem, familiarize yourself with each symbol.

Direction mark

A direction mark is shown to clarify the side of connector (terminal side or harness side).

Direction marks are mainly used in the illustrations indicating terminal inspection.



: View from terminal side ... T.S.

- All connector symbols shown from the terminal side are enclosed by a single line.







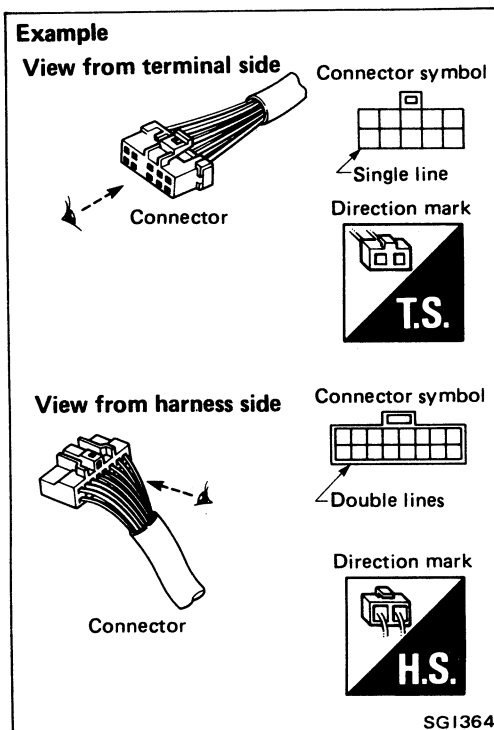









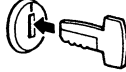







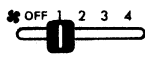

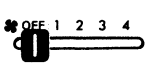



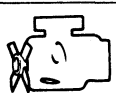
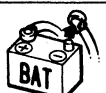

: View from harness side ... H.S.

- All connector symbols shown from the harness side are enclosed by a double line.

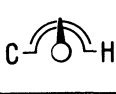

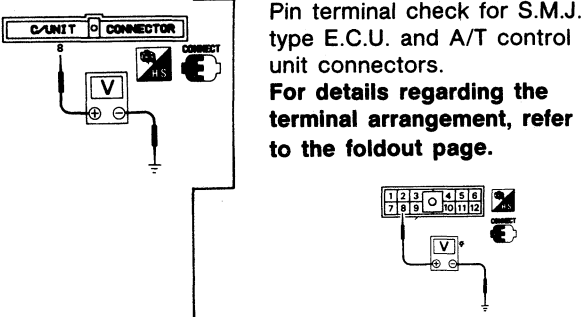
HOW TO FOLLOW FLOW CHART IN TROUBLE DIAGNOSES

Key to symbols signifying measurements or procedures

Symbol	Symbol explanation	Symbol	Symbol explanation
	Check after disconnecting the connector to be measured.		A/C switch is "OFF".
	Check after connecting the connector to be measured.		A/C switch is "ON".
	Insert key into ignition switch.		REC switch is "ON".
	Turn ignition switch to "OFF" position.		REC switch is "OFF".
	Turn ignition switch to "ON" position.		DEF switch is "ON".
	Turn ignition switch to "START" position.		VENT switch is "ON".
	Turn ignition switch from "OFF" to "ACC" position.		Fan switch is "ON". (At any position except for "OFF" position)
	Turn ignition switch from "ACC" to "OFF" position.		Fan switch is "OFF".
	Turn ignition switch from "OFF" to "ON" position.		Apply battery voltage directly to components.
	Turn ignition switch from "ON" to "OFF" position.		Drive vehicle.
	Do not start engine, or check with engine stopped.		Disconnect battery negative cable.
	Start engine, or check with engine running.		Depress brake pedal.
	Apply parking brake.		Release brake pedal.
	Release parking brake.		Depress accelerator pedal.
	Check after engine is warmed up sufficiently.		Release accelerator pedal.
	Voltage should be measured with a voltmeter.		
	Circuit resistance should be measured with an ohmmeter.		
	Circuit resistance should be measured with an ohmmeter.		
	Current should be measured with an ammeter.		

IDENTIFICATION INFORMATION

Model Variation

Destination	Body	Model	Engine	Transmission	Differential carrier
Non-California	Coupe	HLS13FU	KA24E	FS5W71C	R200
	Fastback	RHLS13FU			
	Coupe	HLS13AU		RE4R01A	
	Fastback	RHLS13AU			
California	Coupe	HLS13FV		FS5W71C	
	Fastback	RHLS13FV			
	Coupe	HLS13AV		RE4R01A	
	Fastback	RHLS13AV			
Canada	Coupe	HLS13FN		FS5W71C	
	Fastback	RHLS13FN			
	Coupe	HLS13AN		RE4R01A	
	Fastback	RHLS13AN			

Prefix and suffix designations:

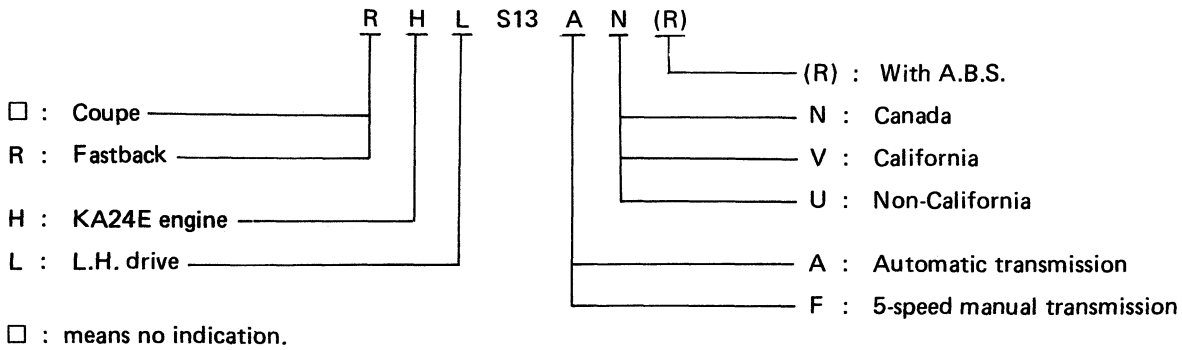

IDENTIFICATION INFORMATION

Identification Number

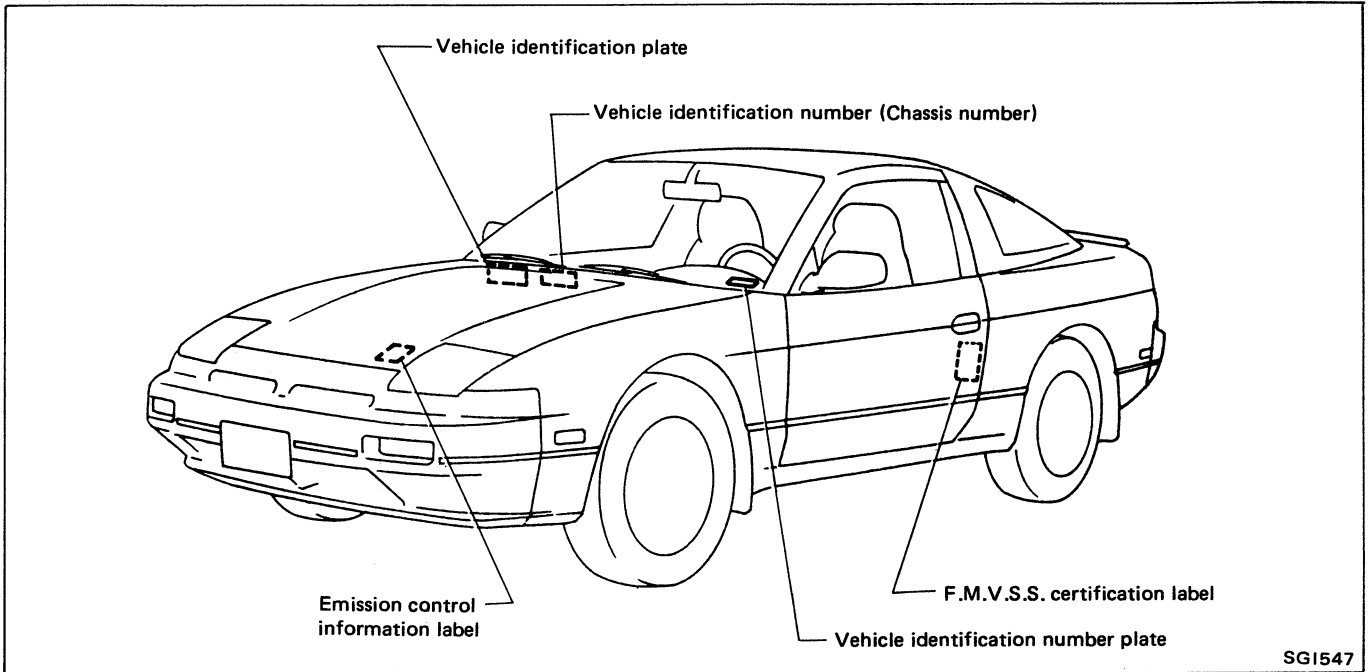

VEHICLE IDENTIFICATION NUMBER ARRANGEMENT

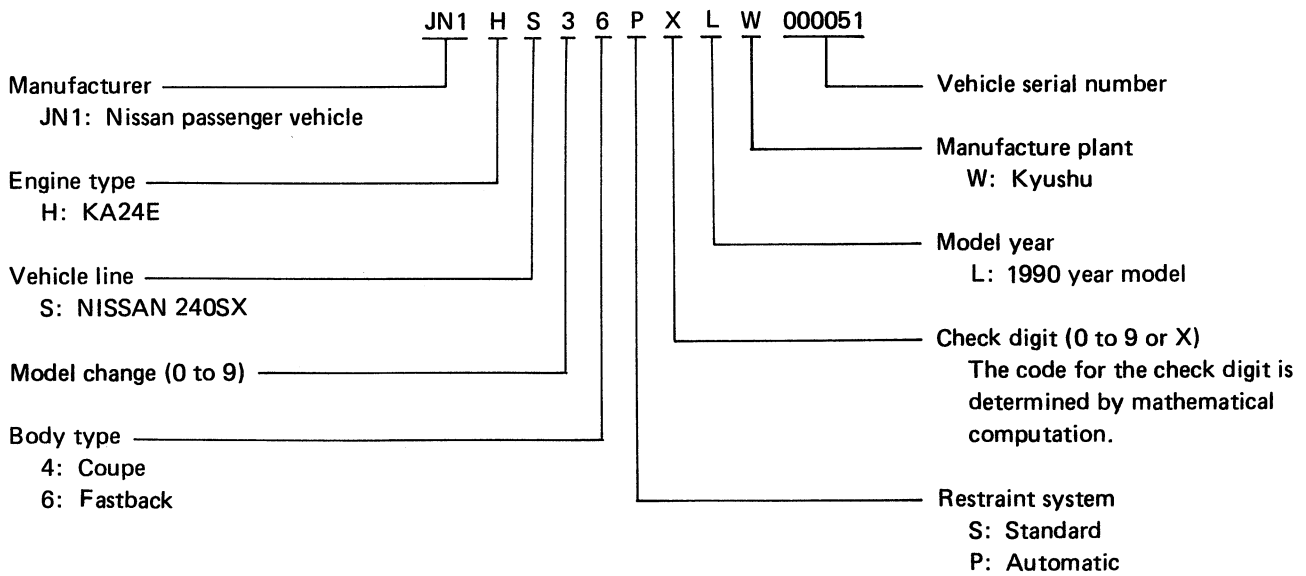

IDENTIFICATION INFORMATION

Identification Number (Cont'd) IDENTIFICATION PLATE

NISSAN MOTOR CO., LTD. JAPAN 型式 TYPE TIPO △		
CHASSIS NO NO DE CHASIS	△	
MODEL MODELO	△	
○ カラー-COLOR TRIM トリム-COLOR GUARNICION	△ △	○
エン ENGINE ジン MOTOR	△ △	CC
ミッション TRANS, AXLE アクスル TRANS, EJE	△ △	
	工場 PLANT PLANTA	
日産自動車株式会社 MADE IN JAPAN		SGI315

- 1 Type
- 2 Vehicle identification number (Chassis number)
- 3 Model
- 4 Body color code
- 5 Trim color code
- 6 Engine model
- 7 Engine displacement
- 8 Transmission model
- 9 Axle model

ENGINE SERIAL NUMBER

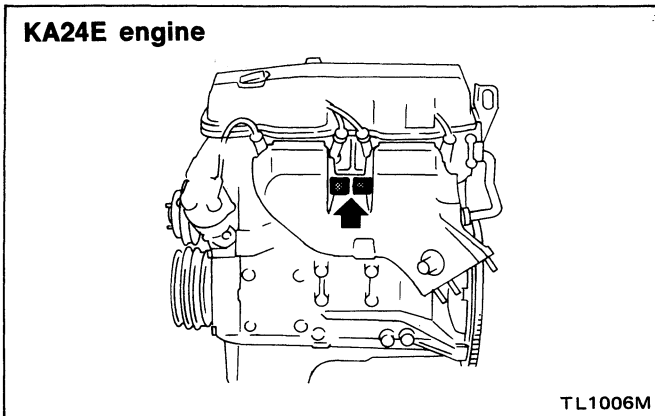

MANUAL TRANSMISSION NUMBER

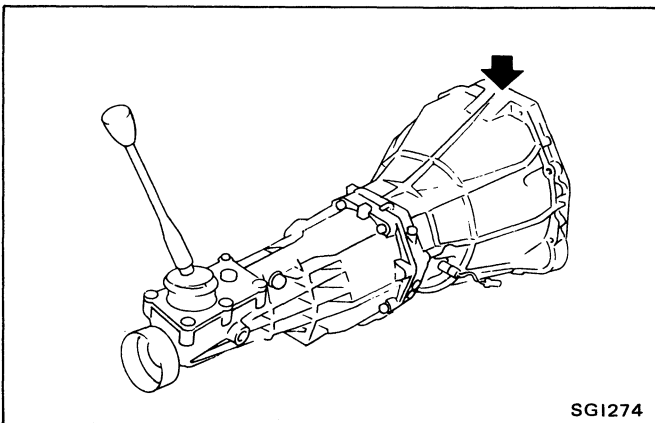

AUTOMATIC TRANSMISSION NUMBER

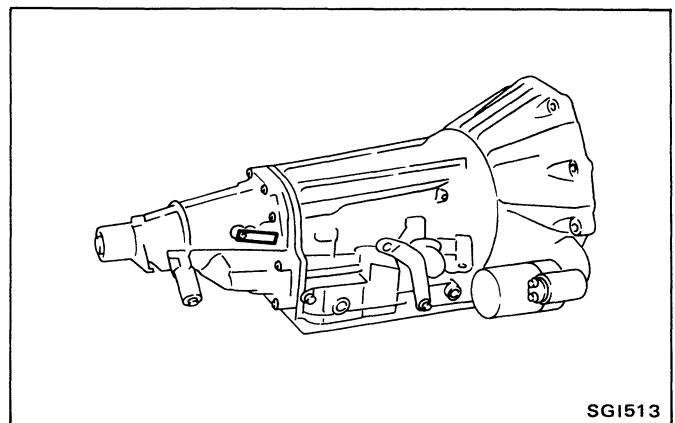

IDENTIFICATION INFORMATION

Dimensions

Unit: mm (in)

	Coupe	Fastback
Overall length	4,520 (178.0)	4,520 (178.0)
Overall width	1,690 (66.5)	1,690 (66.5)
Overall height	1,290 (50.8)	1,290 (50.8)
Front tread	1,465 (57.7)	1,465 (57.7)
Rear tread	1,460 (57.5)	1,460 (57.5)
Wheelbase	2,475 (97.4)	2,475 (97.4)

Wheels and Tires

Road wheel	Steel		6-JJx15, 4Tx15*1
	Aluminum		6-JJx15
	Offset	mm (in)	40 (1.57)
Tire size	Conventional		P195/60R15 86H P205/60R15 89H*2
	Spare		T125/70D15

*1: For spare tire

*2: Option

Garage Jack and Safety Stand

WARNING:

- Never get under the vehicle while it is supported only by the jack. Always use safety stands to support the frame when you have to get under the vehicle.
- Place wheel chocks at the front wheels when the rear wheels are raised and place wheel chocks at the rear wheels when the front wheels are raised.

CAUTION:

Place a wooden or rubber block between safety stand and vehicle body when the supporting body is flat.

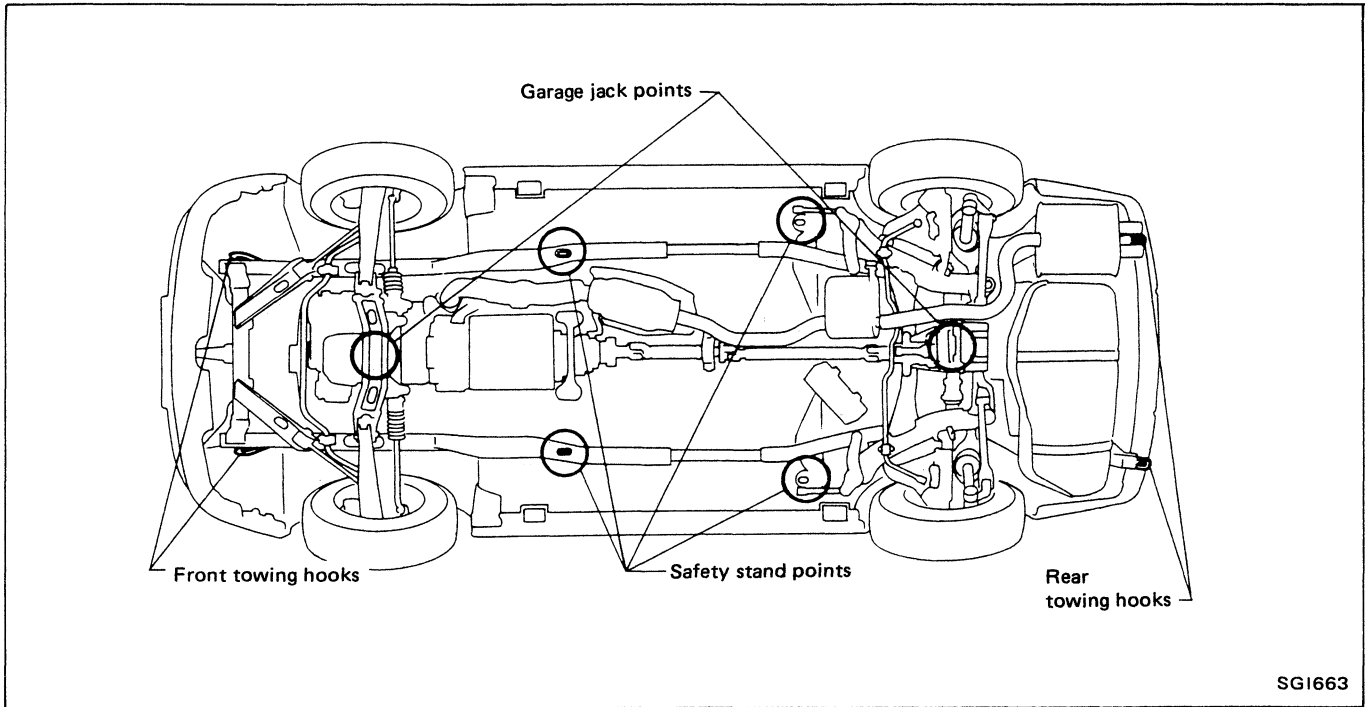

2-pole Lift

WARNING:

When lifting the vehicle, open the lift arms as wide as possible and ensure that the front and rear of the vehicle are well balanced.

When setting the lift arm, do not allow the arm to contact the brake tubes and fuel lines.

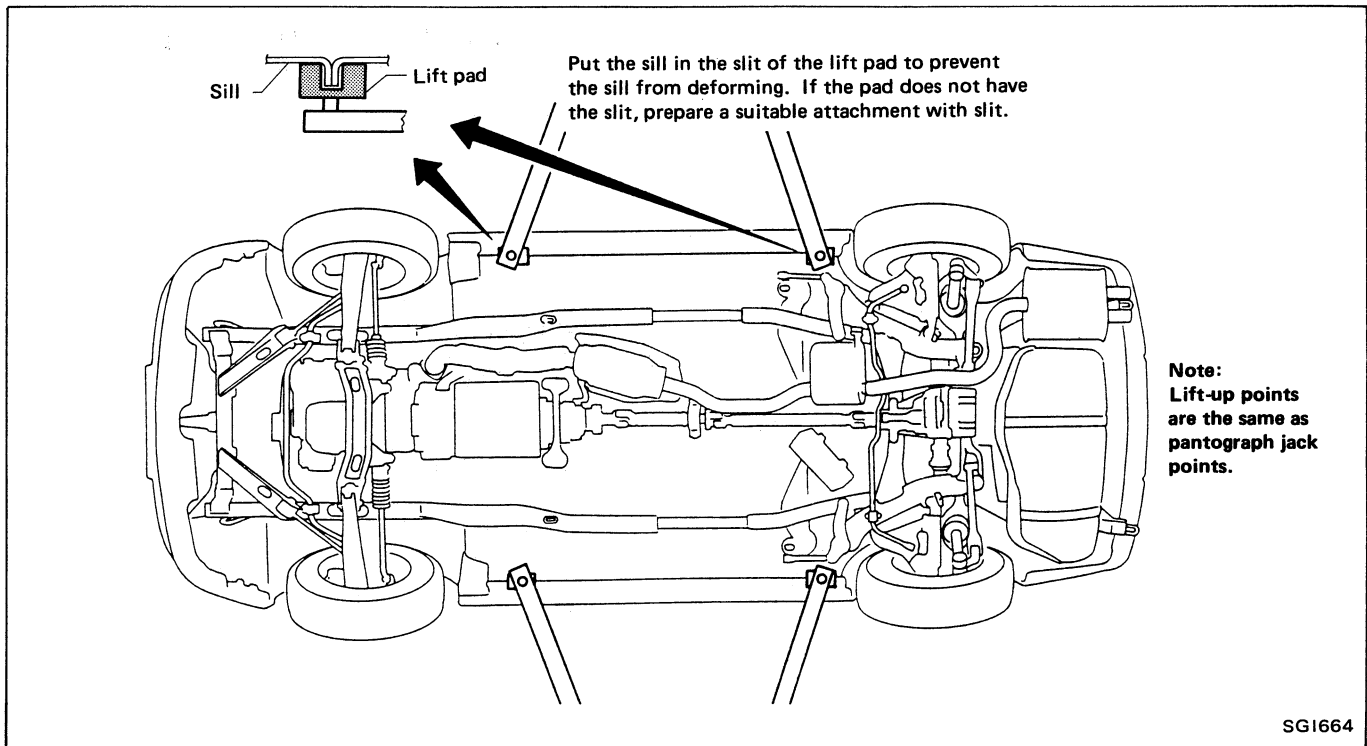

Tow Truck Towing

CAUTION:

- All applicable state or Provincial (in Canada) laws and local laws regarding the towing operation must be obeyed.
- It is necessary to use proper towing equipment to avoid possible damage to the vehicle during towing operation. Towing is in accordance with Towing Procedure Manual at dealer.
- When towing with the rear wheels on the ground, release the parking brake and move the gearshift lever to neutral ("N" position).

NISSAN recommends that vehicle be towed with the driving (rear) wheels off the ground as illustrated.

