

D4DD ENGINE DTC

DTC TROUBLE SHOOTING

BASIC TROUBLESHOOTING	FL- 2	P0502	FL-435
SCHEMATIC CIRCUIT	FL- 10	P0503	FL-446
DTC LIST	FL- 20	P0562	FL-457
P0088	FL- 22	P0563	FL-463
P0093	FL- 36	P0601	FL-469
P0107	FL- 50	P0602	FL-471
P0108	FL- 53	P0606	FL-473
P0112	FL- 57	P0607	FL-475
P0113	FL- 68	P0615	FL-477
P0117	FL- 78	P0627	FL-481
P0118	FL- 85	P0629	FL-491
P0120	FL- 91	P0704	FL-501
P0121	FL-106	P0850	FL-508
P0122	FL-121	P1091	FL-515
P0123	FL-134	P1092	FL-525
P0182	FL-145	P1093	FL-535
P0183	FL-152	P1094	FL-545
P0192	FL-159	P1120	FL-555
P0193	FL-172	P1190	FL-570
P0194	FL-183	P1217	FL-579
P0201	FL-197	P1218	FL-589
P0202	FL-207	P1219	FL-599
P0203	FL-217	P1231	FL-605
P0204	FL-227	P1232	FL-612
P0217	FL-237	P1384	FL-618
P0219	FL-241	P1383	FL-624
P0220	FL-252	P1616	FL-631
P0221	FL-267	P2146	FL-642
P0222	FL-282	P2147	FL-651
P0223	FL-295	P2148	FL-660
P0225	FL-306	P2149	FL-669
P0226	FL-315	P2150	FL-678
P0236	FL-324	P2151	FL-687
P0237	FL-336	P2293	FL-696
P0238	FL-346	P2503	FL-701
P0301	FL-356	P2504	FL-703
P0302	FL-366		
P0303	FL-376		
P0304	FL-386		
P0335	FL-396		
P0340	FL-407		
P0385	FL-419		
P0501	FL-424		

DTC TROUBLESHOOTING PROCEDURES

BASIC TROUBLESHOOTING E557CB8D

BASIC TROUBLESHOOTING GUIDE

1	Bring Vehicle to Workshop
2	Analyze Customer's Complaint. <ul style="list-style-type: none"> Ask the customer about the conditions and environment relative to the issue (Use CUSTOMER PROBLEM ANALYSIS SHEET).
3	Verify Symptom, and then Check DTC and Freeze Frame Data <ul style="list-style-type: none"> Connect scan tool to Diagnostic Link Connector (DLC). Record the DTC and freeze frame data. <p> NOTE To erase DTC and freeze frame data, refer to Step 4.</p>
	Confirm the Inspection Procedure for the System or Part <p>Using the SYMPTOM TROUBLESHOOTING GUIDE CHART, choose the correct inspection procedure for the system or part to be checked.</p>
4	Erase the DTC and Freeze Frame Data <p>(WARNING) NEVER erase DTC and freeze frame data before completing Step 2 MIL/DTC in "CUSTOMER PROBLEM ANALYSIS SHEET".</p>
5	Inspect Vehicle Visually <ul style="list-style-type: none"> Go to Step 10, if you recognize the problem.
6	Recreate (Simulate) Symptoms the DTC <ul style="list-style-type: none"> Try to recreate or simulate the symptoms and conditions of the malfunction as described by customer. If DTC(s) is/are displayed, simulate the condition according to troubleshooting procedure for the DTC.
7	Confirm Symptoms of Problem <ul style="list-style-type: none"> If DTC(s) is/are not displayed, go to Step 8. If DTC(s) is/are displayed, go to Step 10.
8	Recreate (Simulate) Symptom <ul style="list-style-type: none"> Try to recreate or simulate the condition of the malfunction as described by the customer.
9	Check the DTC <ul style="list-style-type: none"> If DTC(s) does(do) not occur, refer to BASIC INSPECTION in INTERMITTENT PROBLEM PROCEDURE. If DTC(s) occur(s), go to Step 10.

10	Perform troubleshooting procedure for DTC
11	Adjust or repair the vehicle
12	Confirmation test
13	END

CUSTOMER PROBLEM ANALYSIS SHEET

1. VEHICLE INFORMATION

(I) VIN:
(II) Production Date:
(III) Odometer Reading: (km)

2. SYMPTOMS

<input type="checkbox"/> Unable to start	<input type="checkbox"/> Engine does not turn over <input type="checkbox"/> Incomplete combustion <input type="checkbox"/> Initial combustion does not occur
<input type="checkbox"/> Difficult to start	<input type="checkbox"/> Engine turns over slowly <input type="checkbox"/> Other _____
<input type="checkbox"/> Poor idle	<input type="checkbox"/> Rough idle <input type="checkbox"/> Incorrect idle <input type="checkbox"/> Unstable idle(High: _____ rpm, Low: _____rpm) <input type="checkbox"/> Other _____
<input type="checkbox"/> Engine stall	<input type="checkbox"/> Soon after starting <input type="checkbox"/> After acceleration pedal depressed <input type="checkbox"/> After acceleration pedal released <input type="checkbox"/> During A/C ON <input type="checkbox"/> Shifting from N to D-range <input type="checkbox"/> Other _____
<input type="checkbox"/> Others	<input type="checkbox"/> Poor driving (Surge) <input type="checkbox"/> Knocking <input type="checkbox"/> Poor fuel economy <input type="checkbox"/> Back fire <input type="checkbox"/> After fire <input type="checkbox"/> Other _____

3. ENVIRONMENT

Problem frequency	<input type="checkbox"/> Constant <input type="checkbox"/> Sometimes (_____) <input type="checkbox"/> Once only <input type="checkbox"/> Other _____
Weather	<input type="checkbox"/> Fine <input type="checkbox"/> Cloudy <input type="checkbox"/> Rainy <input type="checkbox"/> Snowy <input type="checkbox"/> Other _____
Outdoor temperature	Approx. _____ °C/°F
Place	<input type="checkbox"/> Highway <input type="checkbox"/> Suburbs <input type="checkbox"/> Inner City <input type="checkbox"/> Uphill <input type="checkbox"/> Downhill <input type="checkbox"/> Rough road <input type="checkbox"/> Other _____
Engine temperature	<input type="checkbox"/> Cold <input type="checkbox"/> Warming up <input type="checkbox"/> After warming up <input type="checkbox"/> Any temperature
Engine operation	<input type="checkbox"/> Starting <input type="checkbox"/> Just after starting (____ min) <input type="checkbox"/> Idle <input type="checkbox"/> Racing <input type="checkbox"/> Driving <input type="checkbox"/> Constant speed <input type="checkbox"/> Acceleration <input type="checkbox"/> Deceleration <input type="checkbox"/> A/C switch ON/OFF <input type="checkbox"/> Other _____

4. MIL/DTC

MIL (Malfunction Indicator Lamp)	<input type="checkbox"/> Remains ON <input type="checkbox"/> Sometimes lights up <input type="checkbox"/> Does not light
DTC	<input type="checkbox"/> Normal <input type="checkbox"/> DTC (_____) <input type="checkbox"/> Freeze Frame Data

BASIC INSPECTION PROCEDURE

MEASURING CONDITION OF ELECTRONIC PARTS' RESISTANCE

The measured resistance at high temperature after vehicle running may be high or low. So all resistance must be measured at ambient temperature (20°C, 68°F), unless there is any notice.

NOTE

The measured resistance in except for ambient temperature (20°C, 68°F) is reference value.

INTERMITTENT PROBLEM INSPECTION PROCEDURE

Sometimes the most difficult case in troubleshooting is when a problem symptom occurs but does not occur again during testing. An example would be if a problem appears only when the vehicle is cold but has not appeared when warm. In this case, technician should thoroughly make out a "CUSTOMER PROBLEM ANALYSIS SHEET" and recreate (simulate) the environment and condition which occurred when the vehicle was having the issue.

1. Clear Diagnostic Trouble Code (DTC).
2. Inspect connector connection, and check terminal for poor connections, loose wires, bent, broken or corroded pins, and then verify that the connectors are always securely fastened.

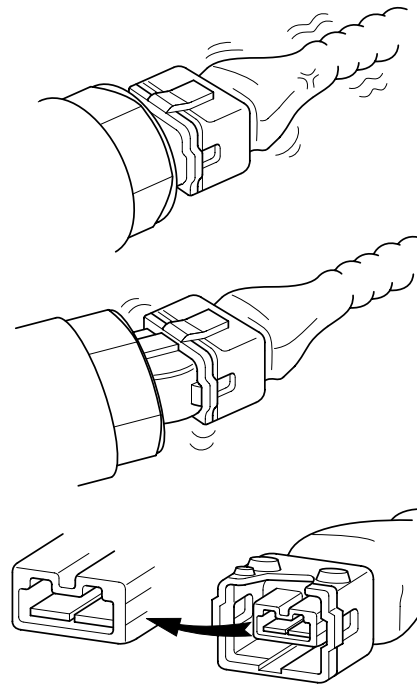

BFG321A

3. Slightly shake the connector and wiring harness vertically and horizontally.
4. Repair or replace the component that has a problem.
5. Verify that the problem has disappeared with the road test.

● **SIMULATING VIBRATION**

- a. Sensors and Actuators : Slightly vibrate sensors, actuators or relays with finger.

⊗ **WARNING**

Strong vibration may break sensors, actuators or relays

- b. Connectors and Harness : Lightly shake the connector and wiring harness vertically and then horizontally.

● SIMULATING HEAT

- a. Heat components suspected of causing the malfunction with a hair dryer or other heat source.

⊗ WARNING

- DO NOT heat components to the point where they may be damaged.
- DO NOT heat the ECM directly.

● SIMULATING WATER SPRINKLING

- a. Sprinkle water onto vehicle to simulate a rainy day or a high humidity condition.

⊗ WARNING

DO NOT sprinkle water directly into the engine compartment or electronic components.

● SIMULATING ELECTRICAL LOAD

- a. Turn on all electrical systems to simulate excessive electrical loads (Radios, fans, lights, etc.).

CONNECTOR INSPECTION PROCEDURE

1. Handling of Connector

- a. Never pull on the wiring harness when disconnecting connectors.

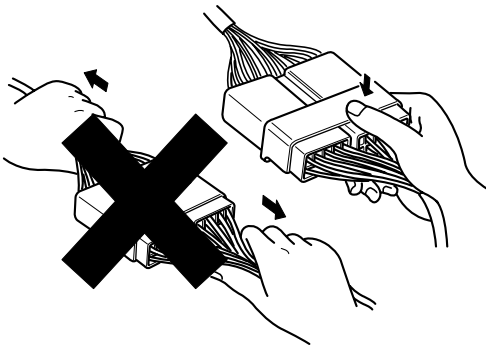

BFG015F

- b. When removing the connector with a lock, press or pull locking lever.

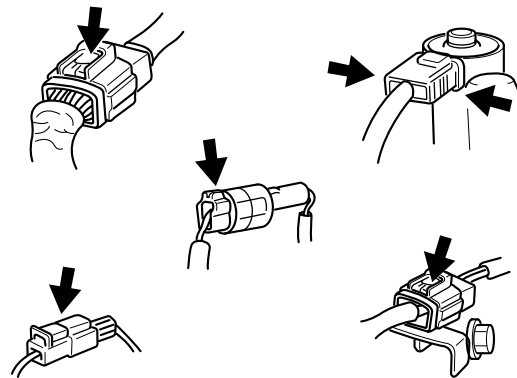

BFG015G

- c. Listen for a click when locking connectors. This sound indicates that they are securely locked.

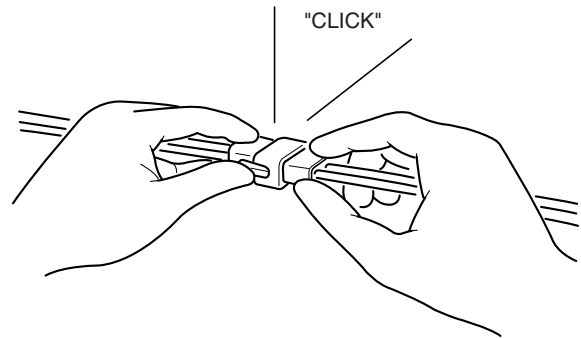

BFG015H

- d. When a tester is used to check for continuity, or to measure voltage, always insert tester probe from wire harness side.

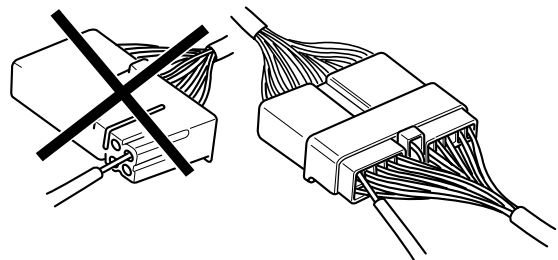

BFG015I

- e. Check waterproof connector terminals from the connector side. Waterproof connectors cannot be accessed from harness side.

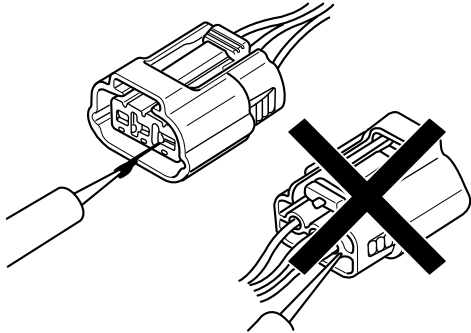

BFG015J

NOTE

- Use a fine wire to prevent damage to the terminal.
- Do not damage the terminal when inserting the tester lead.

2. Checking Point for Connector

- a. While the connector is connected: Hold the connector, check connecting condition and locking efficiency.
- b. When the connector is disconnected: Check missed terminal, crimped terminal or broken core wire by slightly pulling the wire harness. Visually check for rust, contamination, deformation and bend.
- c. Check terminal tightening condition: Insert a spare male terminal into a female terminal, and then check terminal tightening conditions.
- d. Pull lightly on individual wires to ensure that each wire is secured in the terminal.

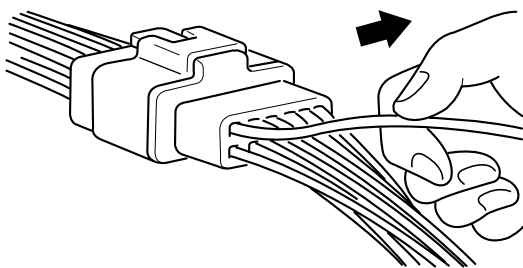

BFG015K

3. Repair Method of Connector Terminal

- a. Clean the contact points using air gun and/or shop rag.

NOTE

Never use sand paper when polishing the contact points, otherwise the contact point may be damaged.

- b. In case of abnormal contact pressure, replace the female terminal.

WIRE HARNESS INSPECTION PROCEDURE

1. Before removing the wire harness, check the wire harness position and crimping in order to restore it correctly.
2. Check whether the wire harness is twisted, pulled or loosened.
3. Check whether the temperature of the wire harness is abnormally high.
4. Check whether the wire harness is rotating, moving or vibrating against the sharp edge of a part.
5. Check the connection between the wire harness and any installed part.
6. If the covering of wire harness is damaged; secure, repair or replace the harness.

ELECTRICAL CIRCUIT INSPECTION PROCEDURE

● CHECK OPEN CIRCUIT

1. Procedures for Open Circuit
 - Continuity Check
 - Voltage Check

If an open circuit occurs (as seen in [FIG. 1]), it can be found by performing Step 2 (Continuity Check Method) or Step 3 (Voltage Check Method) as shown below.

FIG 1

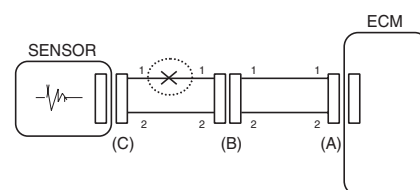

2. Continuity Check Method

NOTE

When measuring for resistance, lightly shake the wire harness above and below or from side to side.

Specification (Resistance)

1Ω or less → Normal Circuit

1MΩ or Higher → Open Circuit

- a. Disconnect connectors (A), (C) and measure resistance between connector (A) and (C) as shown in [FIG. 2].

In [FIG.2.] the measured resistance of line 1 and 2 is higher than 1MΩ and below 1 Ω respectively. Specifically the open circuit is line 1 (Line 2 is normal). To find exact break point, check sub line of line 1 as described in next step.

FIG 2

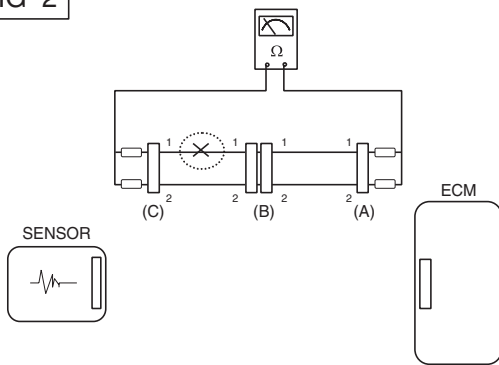

BFG501B

- b. Disconnect connector (B), and measure for resistance between connector (C) and (B1) and between (B2) and (A) as shown in [FIG. 3].

In this case the measured resistance between connector (C) and (B1) is higher than 1MΩ and the open circuit is between terminal 1 of connector (C) and terminal 1 of connector (B1).

FIG 3

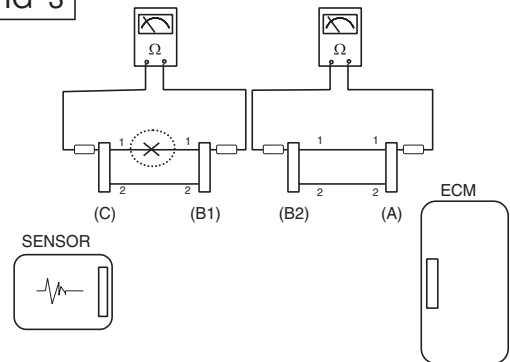

BFG501C

3. Voltage Check Method

- a. With each connector still connected, measure the voltage between the chassis ground and terminal 1 of each connectors (A), (B) and (C) as shown in [FIG. 4].

The measured voltage of each connector is 5V, 5V and 0V respectively. So the open circuit is between connector (C) and (B).

FIG 4

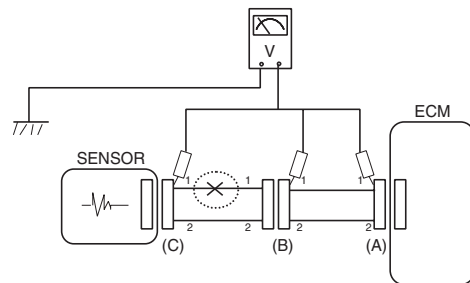

BFG501D

● CHECK SHORT CIRCUIT

1. Test Method for Short to Ground Circuit
 - Continuity Check with Chassis Ground

If short to ground circuit occurs as shown in [FIG. 5], the broken point can be found by performing below Step 2 (Continuity Check Method with Chassis Ground) as shown below.

FIG 5

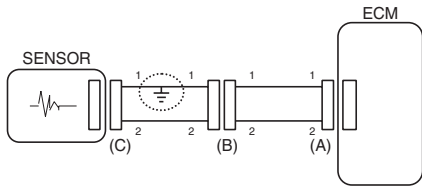

BFG501E

2. Continuity Check Method (with Chassis Ground)

NOTE

Lightly shake the wire harness above and below, or from side to side when measuring the resistance.

Specification (Resistance)

- 1Ω or less → Short to Ground Circuit
- 1MΩ or Higher → Normal Circuit

- a. Disconnect connectors (A), (C) and measure for resistance between connector (A) and Chassis Ground as shown in [FIG. 6].

The measured resistance of line 1 and 2 in this example is below 1 Ω and higher than 1MΩ respectively. Specifically the short to ground circuit is line 1 (Line 2 is normal). To find exact broken point, check the sub line of line 1 as described in the following step.

FIG 6

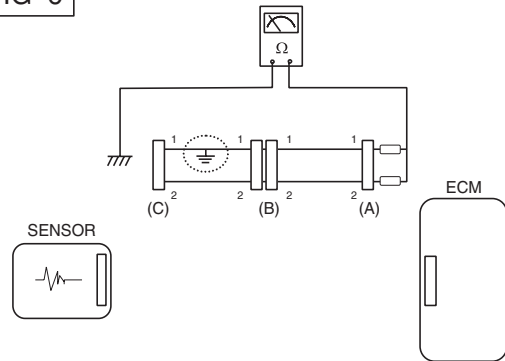

BFG501F

- b. Disconnect connector (B), and measure the resistance between connector (A) and chassis ground, and between (B1) and chassis ground as shown in [FIG. 7].

The measured resistance between connector (B1) and chassis ground is 1Ω or less. The short to ground circuit is between terminal 1 of connector (C) and terminal 1 of connector (B1).

FIG 7

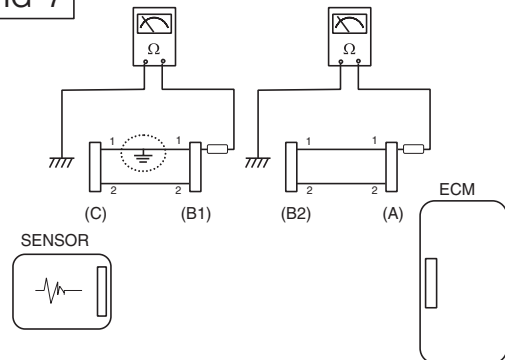

BFG501G

ECM(TICS) PROBLEM INSPECTION PROCEDURE

1. Test ECM(TICS) connector: Disconnect the ECM(TICS) connector and visually check the ground terminals on ECM(TICS) side and harness side for bent pins or poor contact pressure. If the problem is found, repair it.
2. If problem is not found step 1, the ECM(TICS) could be faulty. If so, replace the ECM(TICS) with a new one, and then check the vehicle again. If the vehicle operates normally then the problem was likely with the ECM(TICS).
3. Re-test the original ECM(TICS): Install the original ECM(TICS)(may be broken) into a known-good vehicle and check the vehicle. If the problem occurs again, replace the original ECM(TICS) with a new one. If problem does not occur, this is intermittent problem (Refer to Intermittent Problem Procedure in Basic Inspection Procedure.)

ABBREVIATION

ABS: Anti-lock brake system
APS: Accelerator pedal sensor
A/C: Air conditioning
B: Battery
BATT: Battery
Comp: Compressor
DTC : Diagnostic trouble code
ECTS: Engine coolant temperature sensor
ECU: Electronic control unit
ETCM: Electronic time control module
EUI: Electronic unit injection
IATS : Intake air temperature sensor
IG: Ignition
MIL: Malfunction indicator lamp(Check engine lamp)
NTC: Negative Temperature Coefficient
PTO: Power take-off
NC: Normal close
NO: Normal open
RPM: Revolution per minute
Sw: Switch
Sig: Signal

SCHEMATIC CIRCUIT

E6AD73F3

DATA LINK DETAILS (1)

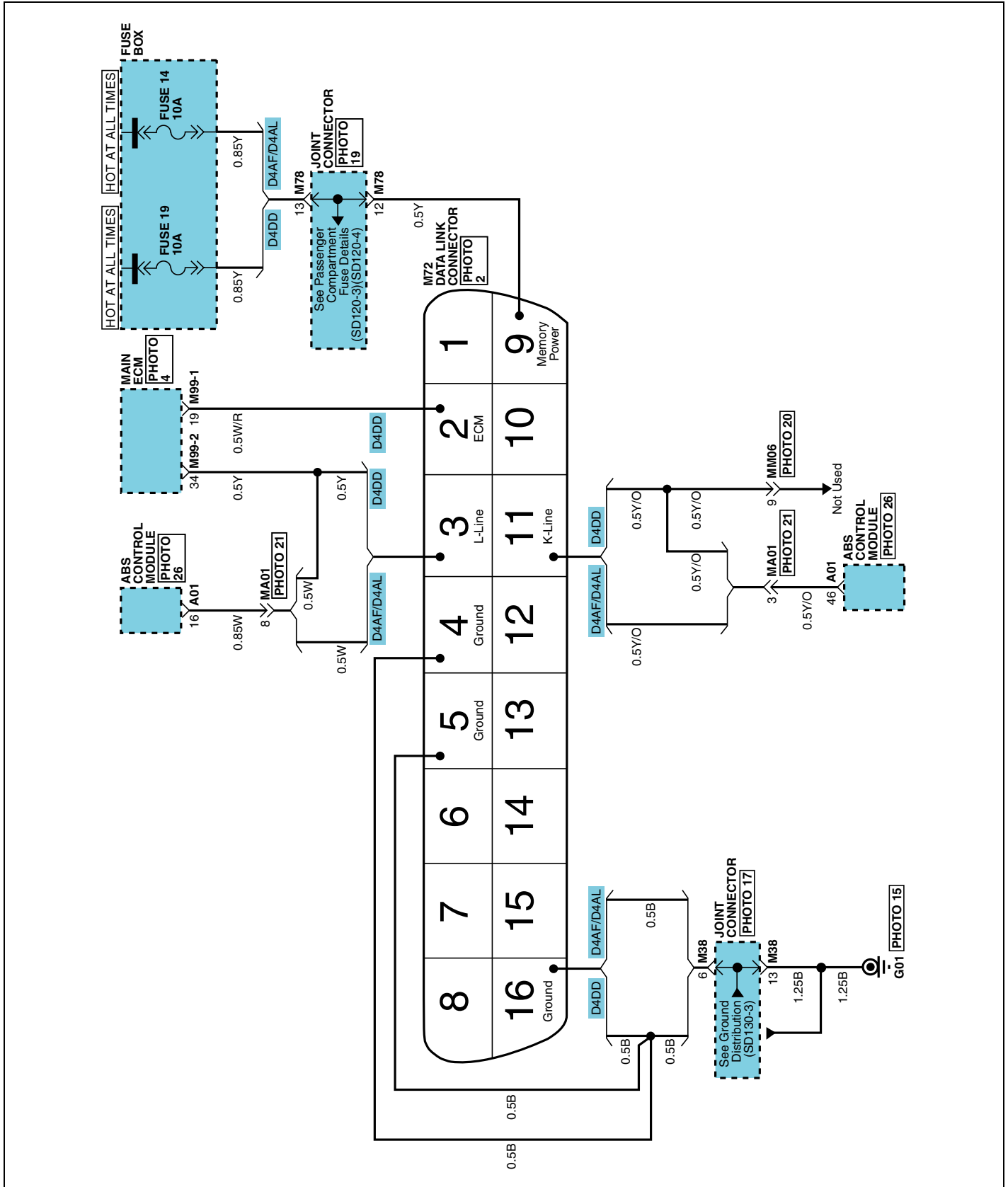

DATA LINK DETAILS (2)

<p>A01</p> <table border="1"> <tr><td>28</td><td>*</td><td>26</td><td>25</td><td>*</td><td>*</td><td>*</td><td>*</td><td>19</td><td>*</td><td>*</td><td>*</td><td>*</td><td>16</td><td>*</td><td>*</td><td>14</td><td>13</td><td>12</td><td>11</td><td>10</td><td>9</td><td>*</td><td>7</td><td>6</td><td>5</td><td>*</td><td>*</td><td>*</td><td>1</td></tr> <tr><td>55</td><td>54</td><td>53</td><td>*</td><td>*</td><td>49</td><td>48</td><td>*</td><td>*</td><td>46</td><td>45</td><td>*</td><td>*</td><td>*</td><td>*</td><td>*</td><td>*</td><td>*</td><td>40</td><td>39</td><td>*</td><td>37</td><td>*</td><td>35</td><td>34</td><td>33</td><td>*</td><td>31</td><td>30</td><td>29</td></tr> <tr><td>*</td><td>*</td><td>*</td><td>*</td><td>*</td><td>*</td><td>*</td><td>*</td><td>*</td><td>*</td><td>*</td><td>*</td><td>*</td><td>*</td><td>*</td><td>*</td><td>*</td><td>*</td><td>*</td><td>*</td><td>*</td><td>*</td><td>*</td><td>*</td><td>*</td><td>*</td><td>*</td><td>*</td><td>*</td><td>*</td><td>*</td></tr> </table>	28	*	26	25	*	*	*	*	19	*	*	*	*	16	*	*	14	13	12	11	10	9	*	7	6	5	*	*	*	1	55	54	53	*	*	49	48	*	*	46	45	*	*	*	*	*	*	*	40	39	*	37	*	35	34	33	*	31	30	29	*	*	*	*	*	*	*	*	*	*	*	*	*	*	*	*	*	*	*	*	*	*	*	*	*	*	*	*	*	*	*	<p>M72(D4AF/D4AL)</p> <table border="1"> <tr><td>*</td><td>*</td><td>*</td><td>*</td><td>*</td><td>*</td><td>*</td><td>*</td><td>*</td><td>*</td><td>*</td><td>*</td><td>*</td><td>16</td><td>*</td><td>*</td><td>*</td><td>*</td><td>*</td><td>*</td><td>3</td><td>*</td><td>*</td><td>*</td><td>*</td><td>*</td><td>9</td></tr> </table>	*	*	*	*	*	*	*	*	*	*	*	*	*	16	*	*	*	*	*	*	3	*	*	*	*	*	9	<p>M72(D4DD)</p> <table border="1"> <tr><td>*</td><td>*</td><td>*</td><td>*</td><td>*</td><td>*</td><td>*</td><td>*</td><td>*</td><td>*</td><td>*</td><td>*</td><td>*</td><td>16</td><td>*</td><td>*</td><td>*</td><td>*</td><td>*</td><td>*</td><td>2</td><td>*</td><td>*</td><td>*</td><td>*</td><td>9</td></tr> </table>	*	*	*	*	*	*	*	*	*	*	*	*	*	16	*	*	*	*	*	*	2	*	*	*	*	9	<p>CR16F007</p> <p>CR16F044</p>
28	*	26	25	*	*	*	*	19	*	*	*	*	16	*	*	14	13	12	11	10	9	*	7	6	5	*	*	*	1																																																																																																																						
55	54	53	*	*	49	48	*	*	46	45	*	*	*	*	*	*	*	40	39	*	37	*	35	34	33	*	31	30	29																																																																																																																						
*	*	*	*	*	*	*	*	*	*	*	*	*	*	*	*	*	*	*	*	*	*	*	*	*	*	*	*	*	*	*																																																																																																																					
*	*	*	*	*	*	*	*	*	*	*	*	*	16	*	*	*	*	*	*	3	*	*	*	*	*	9																																																																																																																									
*	*	*	*	*	*	*	*	*	*	*	*	*	16	*	*	*	*	*	*	2	*	*	*	*	9																																																																																																																										
<p>M99-1</p> <table border="1"> <tr><td>7</td><td>8</td><td>5</td><td>*</td><td>*</td><td>*</td><td>*</td><td>*</td><td>*</td><td>*</td><td>*</td><td>*</td><td>*</td><td>*</td><td>*</td><td>*</td><td>*</td><td>*</td><td>*</td><td>*</td><td>*</td><td>*</td><td>*</td><td>*</td><td>*</td><td>*</td><td>*</td><td>*</td><td>*</td><td>*</td><td>28</td></tr> <tr><td>*</td><td>*</td><td>*</td><td>*</td><td>*</td><td>*</td><td>*</td><td>*</td><td>*</td><td>*</td><td>*</td><td>*</td><td>*</td><td>*</td><td>*</td><td>*</td><td>*</td><td>*</td><td>*</td><td>*</td><td>*</td><td>*</td><td>*</td><td>*</td><td>*</td><td>*</td><td>*</td><td>*</td><td>*</td><td>*</td><td>*</td></tr> <tr><td>*</td><td>*</td><td>*</td><td>*</td><td>*</td><td>*</td><td>*</td><td>*</td><td>*</td><td>*</td><td>*</td><td>*</td><td>*</td><td>*</td><td>*</td><td>*</td><td>*</td><td>*</td><td>*</td><td>*</td><td>*</td><td>*</td><td>*</td><td>*</td><td>*</td><td>*</td><td>*</td><td>*</td><td>*</td><td>*</td><td>*</td></tr> <tr><td>*</td><td>*</td><td>32</td><td>*</td><td>*</td><td>*</td><td>*</td><td>*</td><td>*</td><td>*</td><td>*</td><td>*</td><td>*</td><td>*</td><td>*</td><td>*</td><td>*</td><td>*</td><td>*</td><td>*</td><td>*</td><td>*</td><td>*</td><td>*</td><td>*</td><td>*</td><td>*</td><td>*</td><td>*</td><td>*</td><td>*</td></tr> </table>	7	8	5	*	*	*	*	*	*	*	*	*	*	*	*	*	*	*	*	*	*	*	*	*	*	*	*	*	*	*	28	*	*	*	*	*	*	*	*	*	*	*	*	*	*	*	*	*	*	*	*	*	*	*	*	*	*	*	*	*	*	*	*	*	*	*	*	*	*	*	*	*	*	*	*	*	*	*	*	*	*	*	*	*	*	*	*	*	*	*	*	*	*	*	*	32	*	*	*	*	*	*	*	*	*	*	*	*	*	*	*	*	*	*	*	*	*	*	*	*	*	*	*	*	<p>BLANK</p>	<p>BLANK</p>	<p>CR16F007</p> <p>CR16F044</p>																				
7	8	5	*	*	*	*	*	*	*	*	*	*	*	*	*	*	*	*	*	*	*	*	*	*	*	*	*	*	*	28																																																																																																																					
*	*	*	*	*	*	*	*	*	*	*	*	*	*	*	*	*	*	*	*	*	*	*	*	*	*	*	*	*	*	*																																																																																																																					
*	*	*	*	*	*	*	*	*	*	*	*	*	*	*	*	*	*	*	*	*	*	*	*	*	*	*	*	*	*	*																																																																																																																					
*	*	32	*	*	*	*	*	*	*	*	*	*	*	*	*	*	*	*	*	*	*	*	*	*	*	*	*	*	*	*																																																																																																																					
<p>M99-2</p> <table border="1"> <tr><td>7</td><td>6</td><td>5</td><td>*</td><td>*</td><td>2</td><td>1</td></tr> <tr><td>19</td><td>*</td><td>17</td><td>16</td><td>15</td><td>14</td><td>13</td><td>12</td><td>11</td><td>10</td><td>9</td><td>*</td></tr> <tr><td>*</td><td>*</td><td>23</td><td>24</td><td>23</td><td>22</td><td>21</td><td>20</td><td>19</td><td>18</td><td>17</td><td>*</td></tr> <tr><td>*</td><td>*</td><td>34</td><td>33</td><td>32</td><td>31</td><td>30</td><td>29</td><td>28</td><td>27</td><td>26</td><td>*</td></tr> </table>	7	6	5	*	*	2	1	19	*	17	16	15	14	13	12	11	10	9	*	*	*	23	24	23	22	21	20	19	18	17	*	*	*	34	33	32	31	30	29	28	27	26	*	<p>BLANK</p>	<p>BLANK</p>	<p>CR34F003</p> <p>CR35F009</p> <p>CR55F005</p>																																																																																																					
7	6	5	*	*	2	1																																																																																																																																													
19	*	17	16	15	14	13	12	11	10	9	*																																																																																																																																								
*	*	23	24	23	22	21	20	19	18	17	*																																																																																																																																								
*	*	34	33	32	31	30	29	28	27	26	*																																																																																																																																								

MFI CONTROL SYSTEM (D4DD) (1)

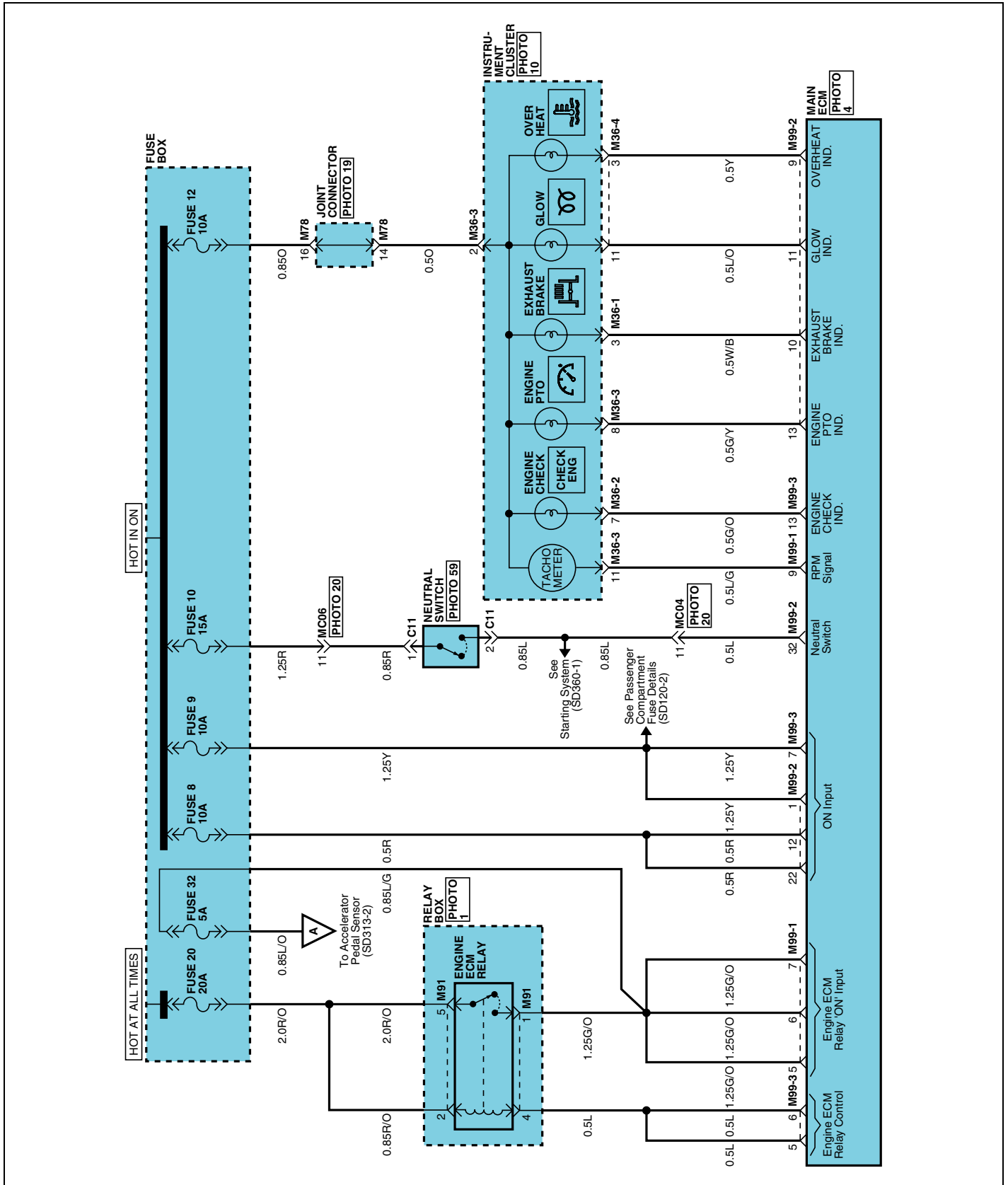

MFI CONTROL SYSTEM (D4DD) (2)

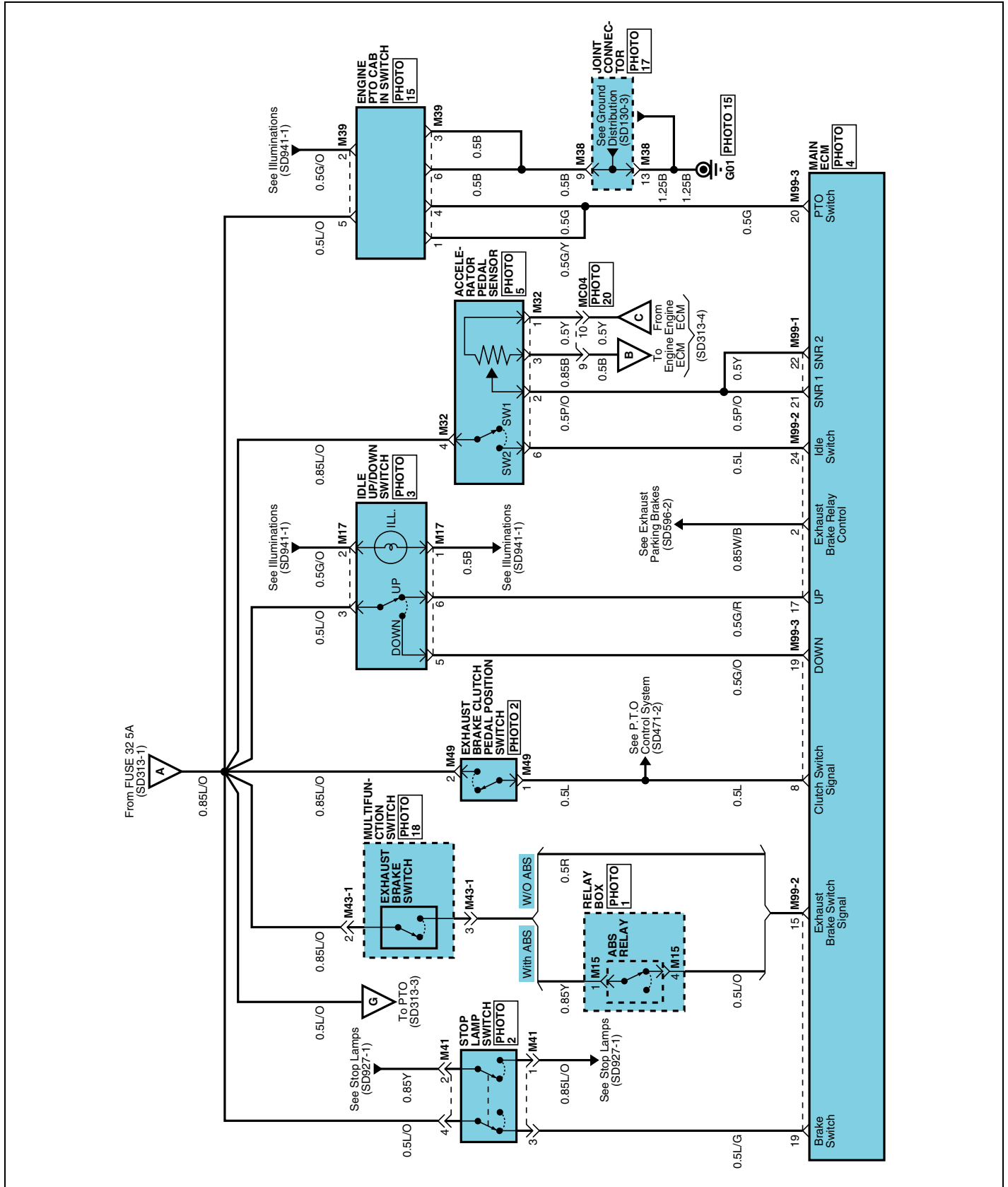



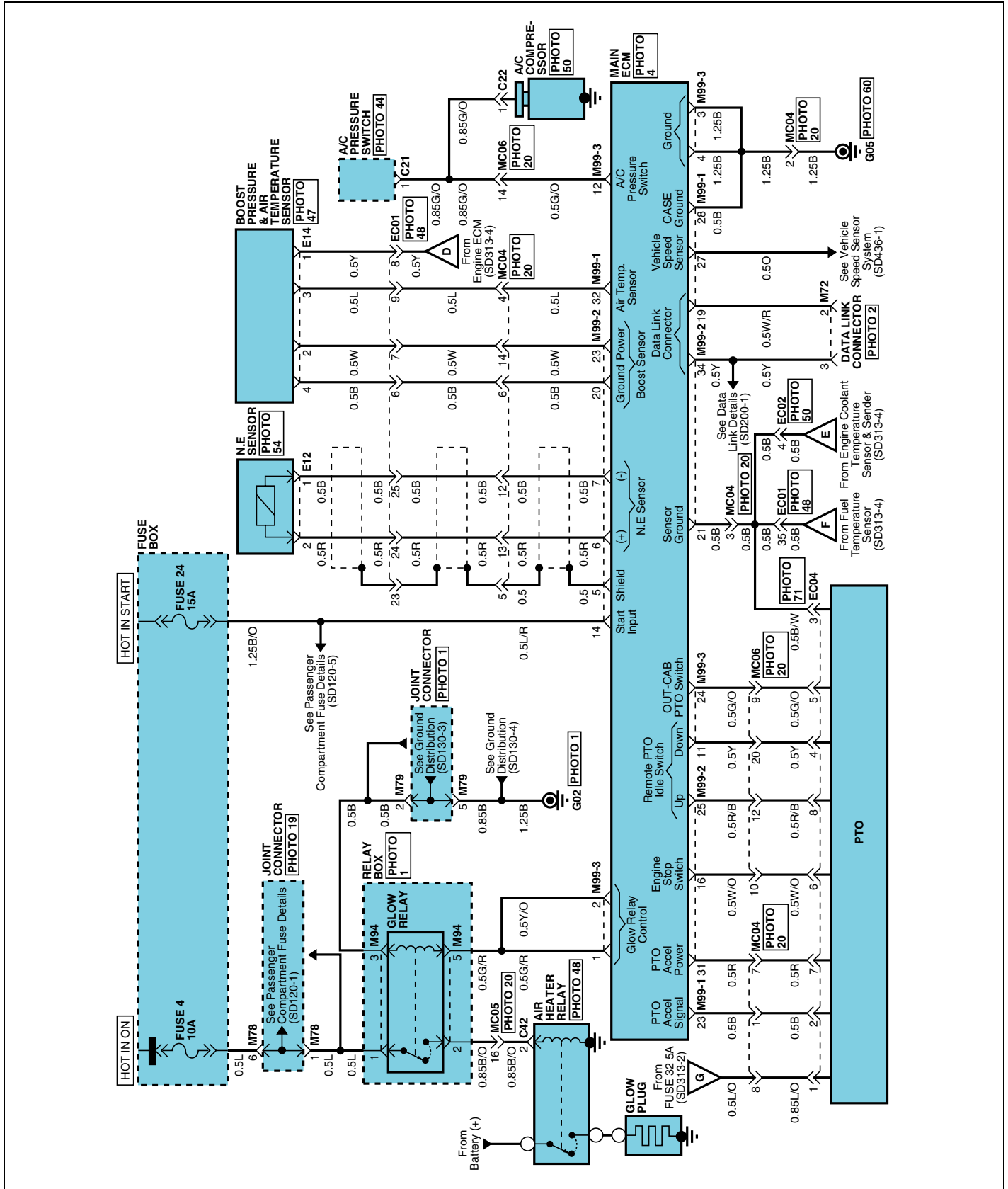



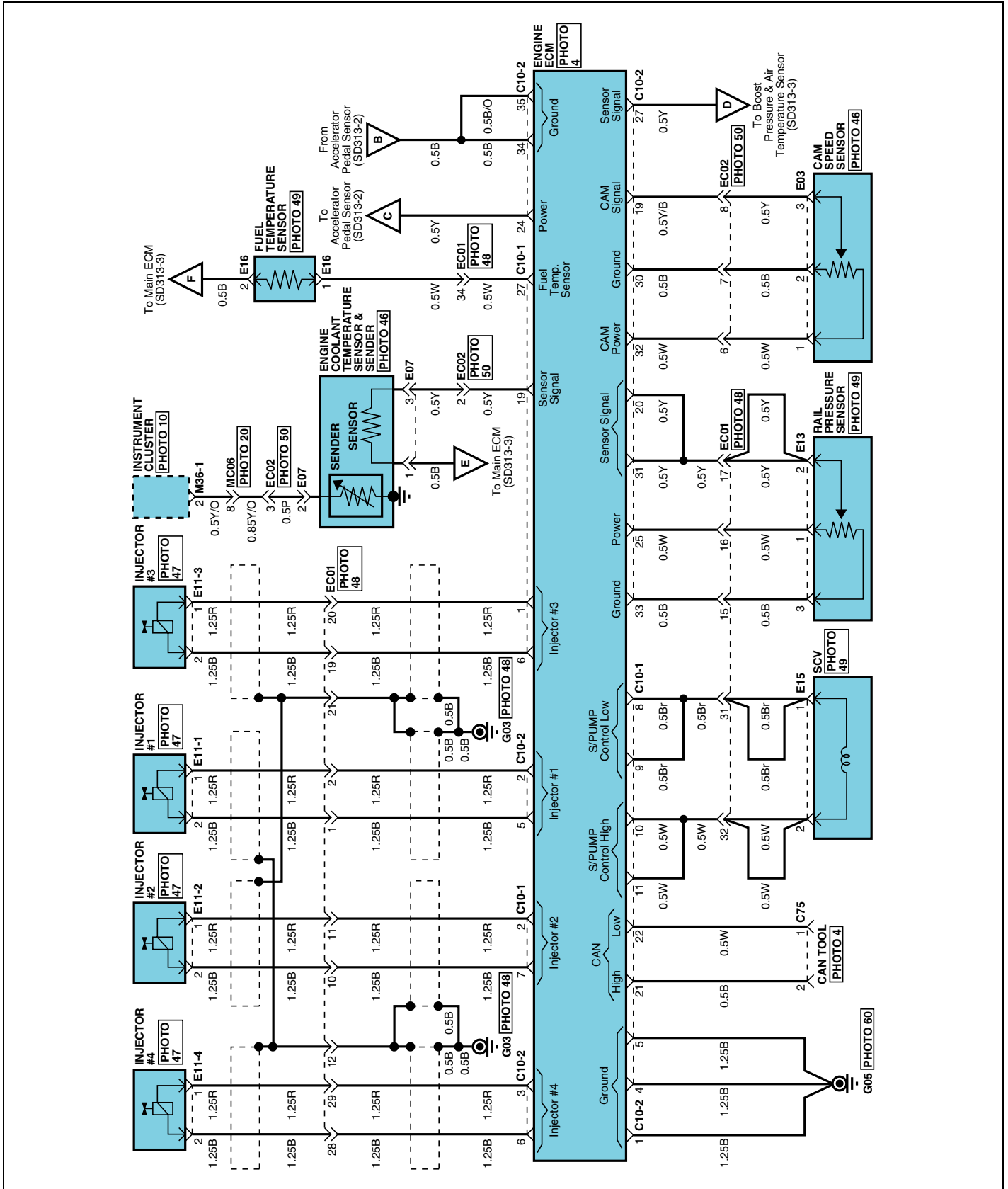

MFI CONTROL SYSTEM (D4DD) (3)

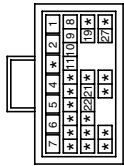
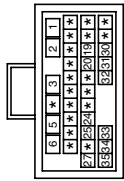



MFI CONTROL SYSTEM (D4DD) (4)

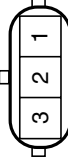
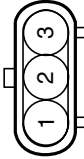
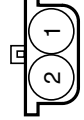
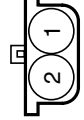
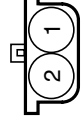
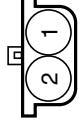
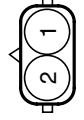
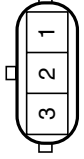
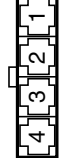
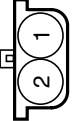
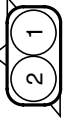

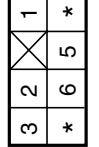
MFI CONTROL SYSTEM (D4DD) (5)

<p>C10-1</p>  <p>CR31F002</p>	<p>C10-2</p>  <p>CR35F008</p>	<p>C11</p>  <p>CR02F040</p>	<p>C21</p>  <p>CR02F025</p>
<p>C22</p>  <p>CR01F020</p>	<p>C42</p>  <p>CR02F040</p>	<p>C75</p>  <p>CR02F046</p>	<p>E03</p>  <p>CR03F230</p>
<p>E07</p>  <p>CR03M019</p>	<p>E11-1</p>  <p>CR02F152</p>	<p>E11-2</p>  <p>CR02F152</p>	<p>E11-3</p>  <p>CR02F152</p>
<p>E11-4</p>  <p>CR02F152</p>	<p>E12</p>  <p>CR02F154</p>	<p>E13</p>  <p>CR03F230</p>	<p>E14</p>  <p>CR04F091</p>
<p>E15</p>  <p>CR02F152</p>	<p>E16</p>  <p>CR02F175</p>	<p>M15</p>  <p>CR05F011</p>	<p>M17</p>  <p>CR07F002</p>

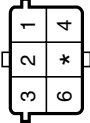
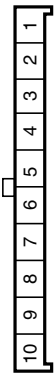
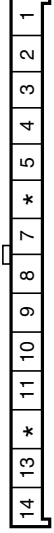
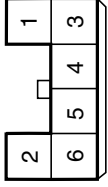
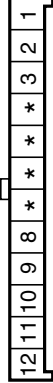
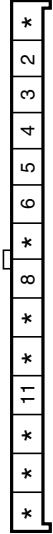
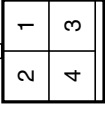
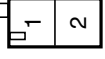
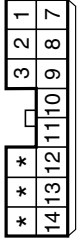

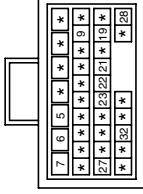
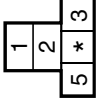
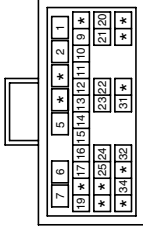
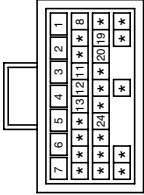
MFI CONTROL SYSTEM (D4DD) (6)

<p>M32</p> 	<p>M36-1</p> 	<p>M36-2</p> 
<p>M39</p> 	<p>M36-4</p> 	<p>M36-3</p> 
<p>M41</p> 	<p>M49</p> 	<p>M43-1</p> 
<p>M72</p> 	<p>M99-1</p> 	<p>M94</p> 
<p>M99-2</p> 	<p>M99-3</p> 	<p>BLANK</p>

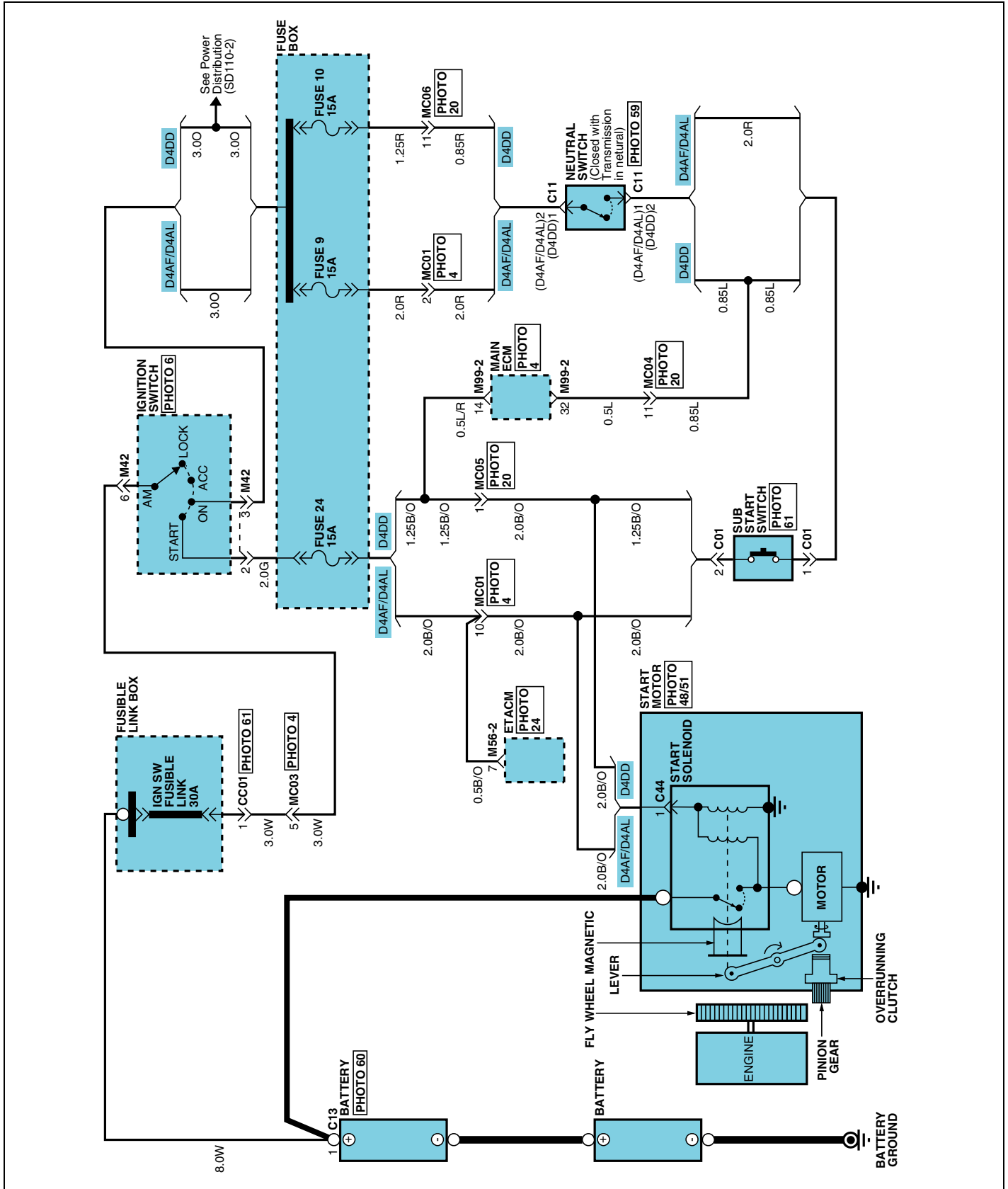
STARTING SYSTEM (1)

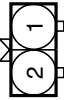
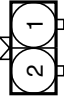

STARTING SYSTEM (2)

<p>C01</p>  <p>M42</p> <table border="1" data-bbox="491 1662 593 1787"> <tr><td>3</td><td>2</td><td>*</td></tr> <tr><td>6</td><td>*</td><td>4</td></tr> </table>	3	2	*	6	*	4	<p>C11</p>  <p>M56-2(D4AF/D4AL)</p> <table border="1" data-bbox="491 1191 577 1451"> <tr><td>8</td><td>7</td><td>6</td><td>5</td><td>4</td><td>*</td><td>*</td><td>1</td></tr> <tr><td>16</td><td>15</td><td>14</td><td>13</td><td>*</td><td>11</td><td>10</td><td>9</td></tr> </table>	8	7	6	5	4	*	*	1	16	15	14	13	*	11	10	9	<p>C13</p>  <p>M99-2</p> <table border="1" data-bbox="466 801 609 1034"> <tr><td>7</td><td>8</td><td>5</td><td>*</td><td>*</td><td>2</td><td>1</td></tr> <tr><td>19</td><td>*</td><td>17</td><td>18</td><td>15</td><td>14</td><td>13</td><td>12</td><td>11</td><td>10</td><td>9</td><td>*</td></tr> <tr><td>*</td><td>*</td><td>25</td><td>24</td><td>23</td><td>22</td><td>21</td><td>20</td><td>*</td><td>*</td></tr> <tr><td>*</td><td>24</td><td>*</td><td>22</td><td>31</td><td>*</td><td>*</td><td>*</td></tr> </table>	7	8	5	*	*	2	1	19	*	17	18	15	14	13	12	11	10	9	*	*	*	25	24	23	22	21	20	*	*	*	24	*	22	31	*	*	*	<p>C44</p>  <p>BLANK</p>
3	2	*																																																												
6	*	4																																																												
8	7	6	5	4	*	*	1																																																							
16	15	14	13	*	11	10	9																																																							
7	8	5	*	*	2	1																																																								
19	*	17	18	15	14	13	12	11	10	9	*																																																			
*	*	25	24	23	22	21	20	*	*																																																					
*	24	*	22	31	*	*	*																																																							
<p>CR01F035</p>	<p>CR01F002</p>	<p>CR02F040</p>	<p>CR06F014</p>																																																											
<p>CR01F009</p>	<p>CR16F002</p>	<p>CR02F040</p>	<p>CR06F014</p>																																																											

DTC LIST

E7D910C2

NO	DTC	DESCRIPTION	Page
1	P0088	COMMON RAIL PRESSURE EXCEEDS LIMIT	
2	P0093	FUEL SYSTEM LEAK DETECTED	
3	P0107	BAROMETRIC PRESSURE SENSOR -LOW VOLTAGE	
4	P0108	BAROMETRIC PRESSURE SENSOR -HIGH VOLTAGE	
5	P0112	INTAKE AIR TEMPERATURE SENSOR - LOW VOLTAGE	
6	P0113	INTAKE AIR TEMPERATURE SENSOR - HIGH VOLTAGE	
7	P0117	ENGINE COOLANT TEMPERATURE SENSOR-LOW VOLTAGE	
8	P0118	ENGINE COOLANT TEMPERATURE SENSOR-HIGH VOLTAGE	
9	P0120	PEDAL SENSOR NO.1 NOT OPEN	
10	P0121	PEDAL SENSOR NO.1 NOT CLOSE	
11	P0122	PEDAL SENSOR NO.1 SIGNAL LOW	
12	P0123	PEDAL SENSOR NO.1 SIGNAL HIGH	
13	P0182	FUEL TEMP. SENSOR LOW INPUT	
14	P0183	FUEL TEMP. SENSOR HIGH INPUT	
15	P0192	C/RAIL PRESSURE SENSOR SIGNAL LOW	
16	P0193	C/RAIL PRESSURE SENSOR SIGNAL HIGH	
17	P0194	C/RAIL PRESSURE SENSOR INTERMITTENT	
18	P0201	INJECTOR #1 COIL OPEN	
19	P0202	INJECTOR #2 COIL OPEN	
20	P0203	INJECTOR #3 COIL OPEN	
21	P0204	INJECTOR #4 COIL OPEN	
22	P0217	ENGINE COOLANT OVER TEMPERATURE	
23	P0219	ENGINE OVERSPEED CONDITION	
24	P0220	PEDAL SENSOR NO.2 NOT OPEN	
25	P0221	PEDAL SENSOR NO.2 NOT CLOSE	
26	P0222	PEDAL SENSOR NO.2 SIGNAL LOW	
27	P0223	PEDAL SENSOR NO.2 SIGNAL HIGH	
28	P0225	IDLE SWITCH STUCK CLOSED	
29	P0226	IDLE SWITCH STUCK OPENED	
30	P0236	BOOST PRESSURE SENSOR INVALID	
31	P0237	BOOST PRESSURE SENSOR SIGNAL LOW	
32	P0238	BOOST PRESSURE SENSOR SIGNAL HIGH	
33	P0301	CYLINDER 1 MISFIRE DETECTED	
34	P0302	CYLINDER 2 MISFIRE DETECTED	
35	P0303	CYLINDER 3 MISFIRE DETECTED	
36	P0304	CYLINDER 4 MISFIRE DETECTED	
37	P0335	CRANK SENSOR NO PULSE	