

TABLE OF CONTENTS

Electrical Circuits

DD80, DD80L - Canopy Model3

DD80, DD80L - Cabin Model4

Hydraulic Circuits

DD80, DD80L6

DD80, DD80L - CANOPY MODEL

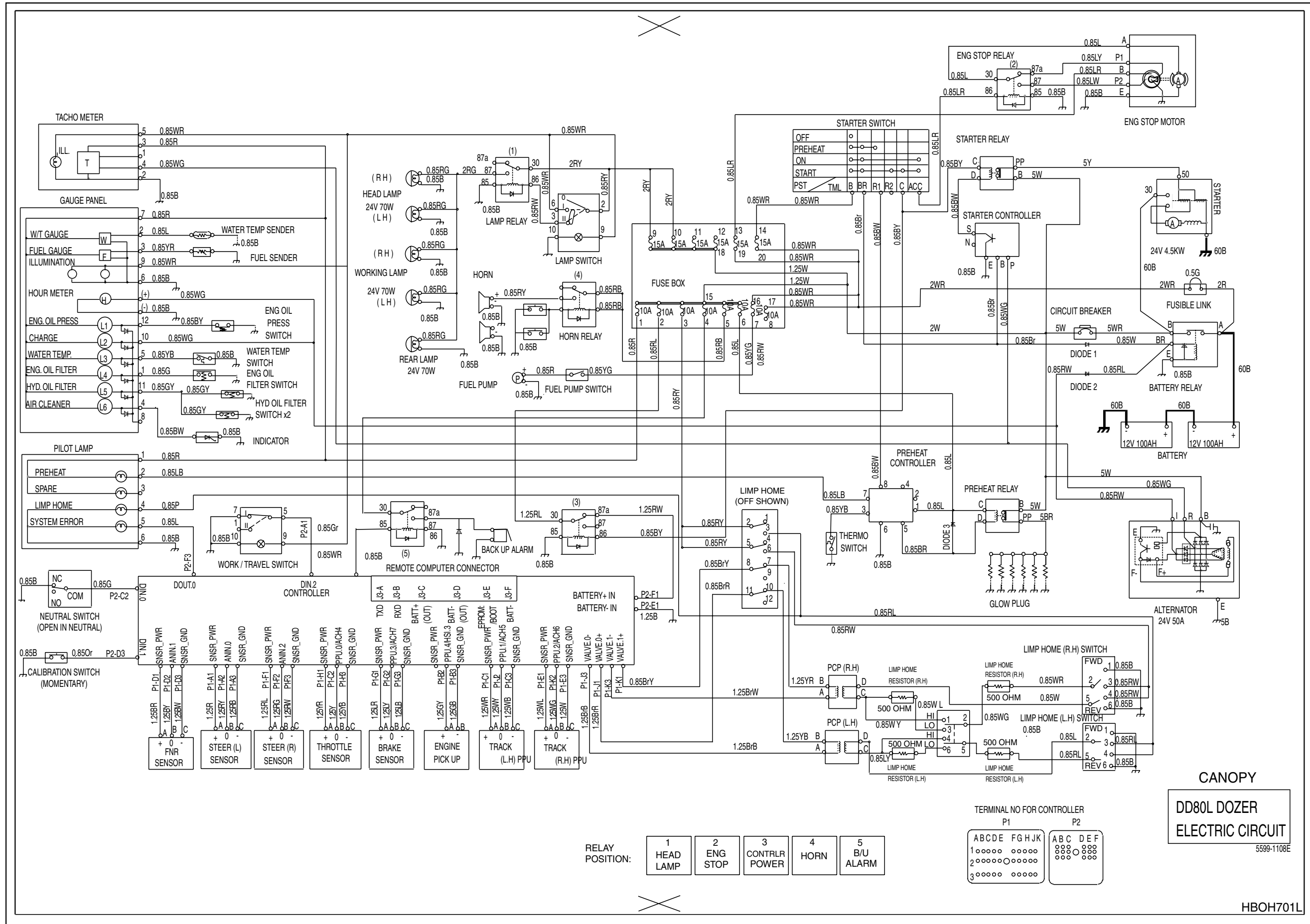

DD80, DD80L - CABIN MODEL

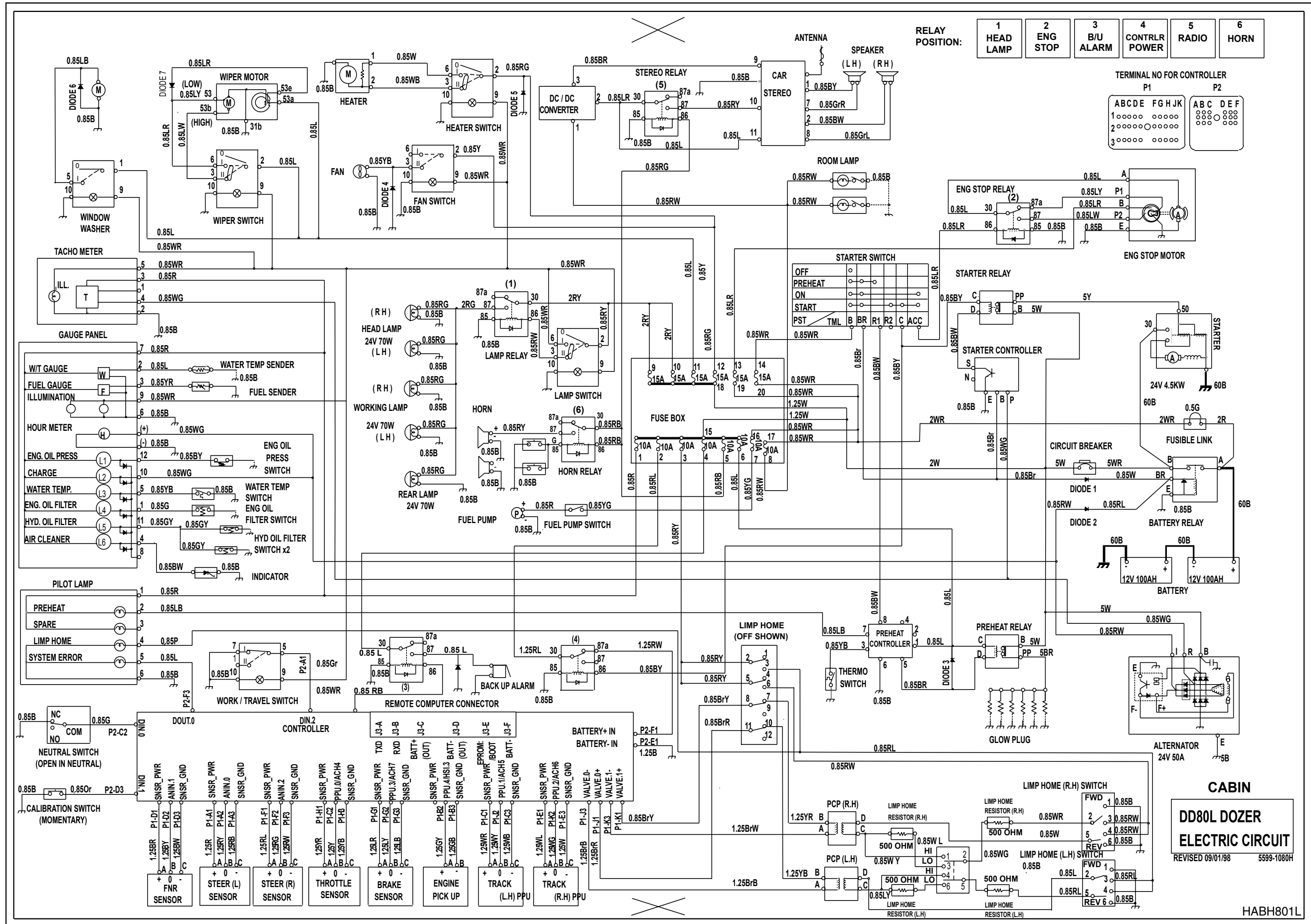

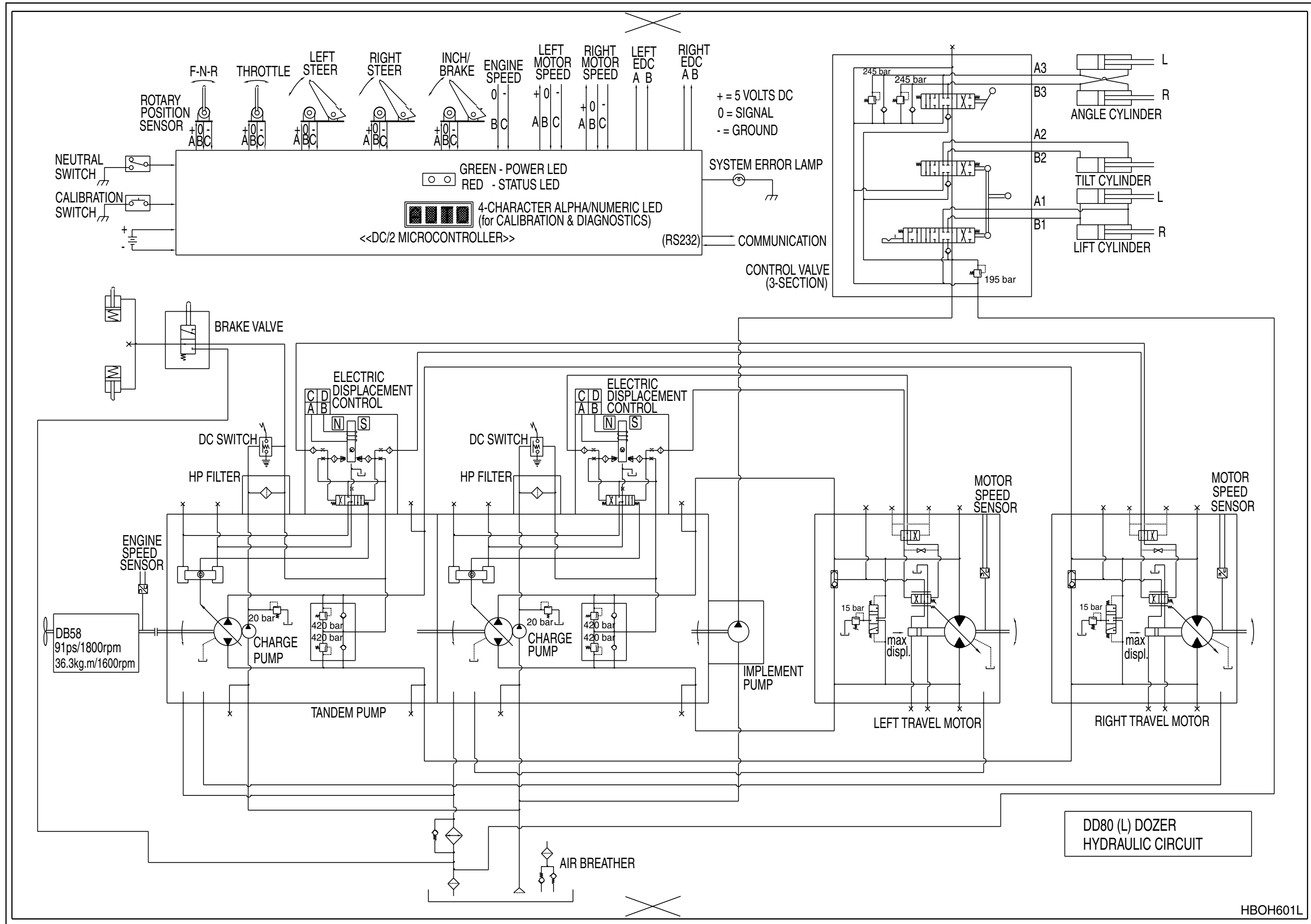

HBOH601L

TABLE OF CONTENTS

Electrical Circuits

DH 030.....	4
DH 050.....	5
DH 050.....	6
DH 130.....	7
DH 130 (S/N 0483 and Up).....	8
DH 130W	9
DH 130-2	10
DH 170.....	11
DH 180 / DH 220	12
DH 200W	13
DH 220LC	14
DH 280LC	15
DH 320LC	16
DH 450.....	17

Hydraulic Circuits

DH 030.....	19
DH 050 (S/N 0001 thru 5600).....	20
DH 050 (S/N 5601 thru 5999).....	21
DH 050 (S/N 6001 and Up).....	22
DH 130.....	23
DH 130W	24
DH 130W	25
DH 130-2	26
DH 170.....	27
DH 180 / DH 200	28
DH 200W	29
DH 200W	30
DH 220 (S/N 0001 thru 1779).....	31
DH 220 (S/N 1780 and Up).....	32
DH 280.....	33
DH 320.....	34

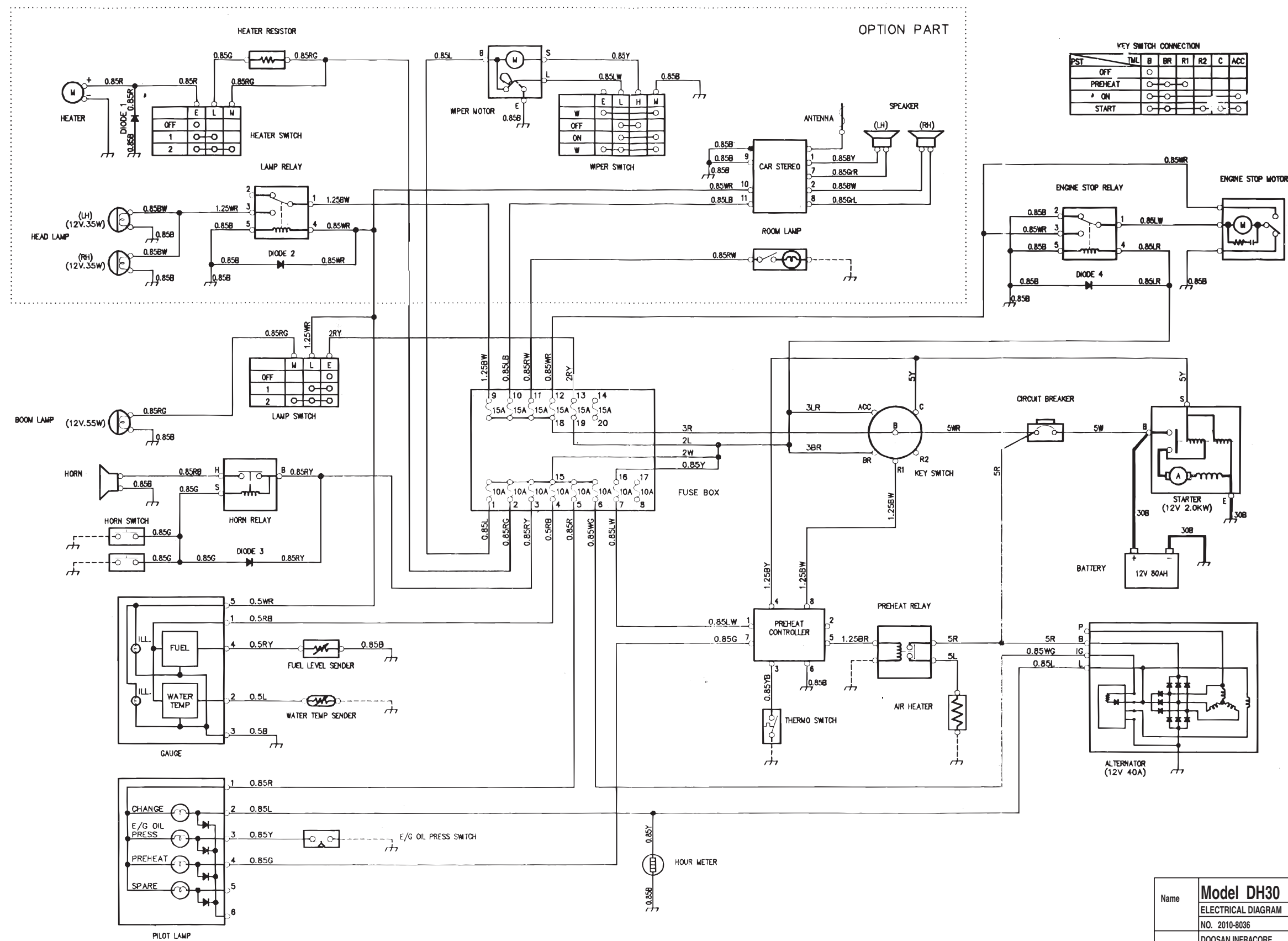

Name	Model DH30
	ELECTRICAL DIAGRAM
	NO. 2010-8036
	DOOSAN INFRACORE

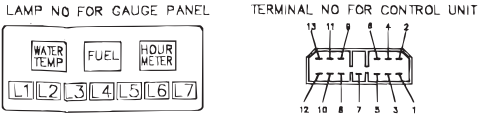
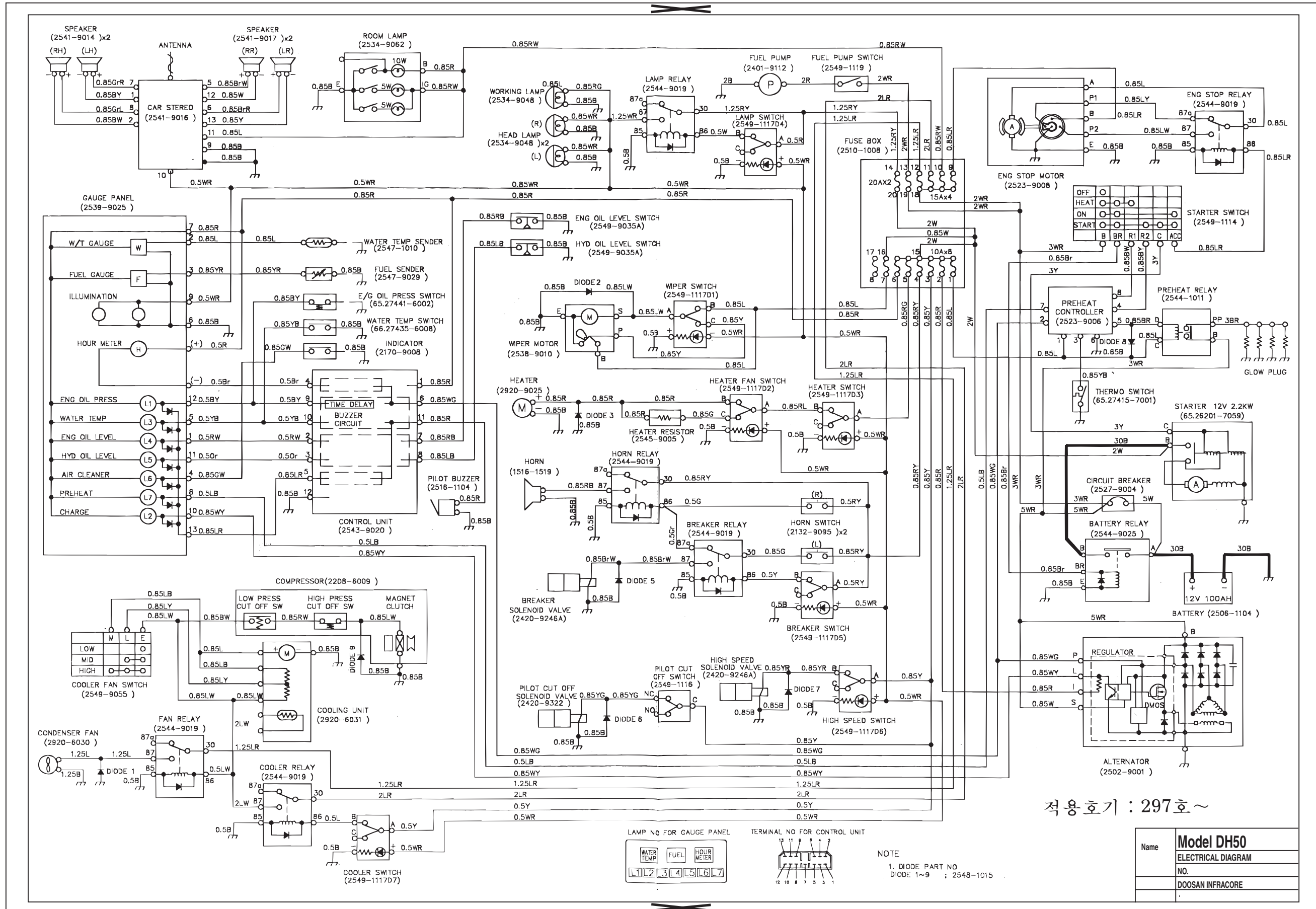

NOTE
1. DIODE PART NO
DIODE 1~9 : 2548-1015

Name	Model DH50
	ELECTRICAL DIAGRAM
NO.	
	DOOSAN INFRACORE

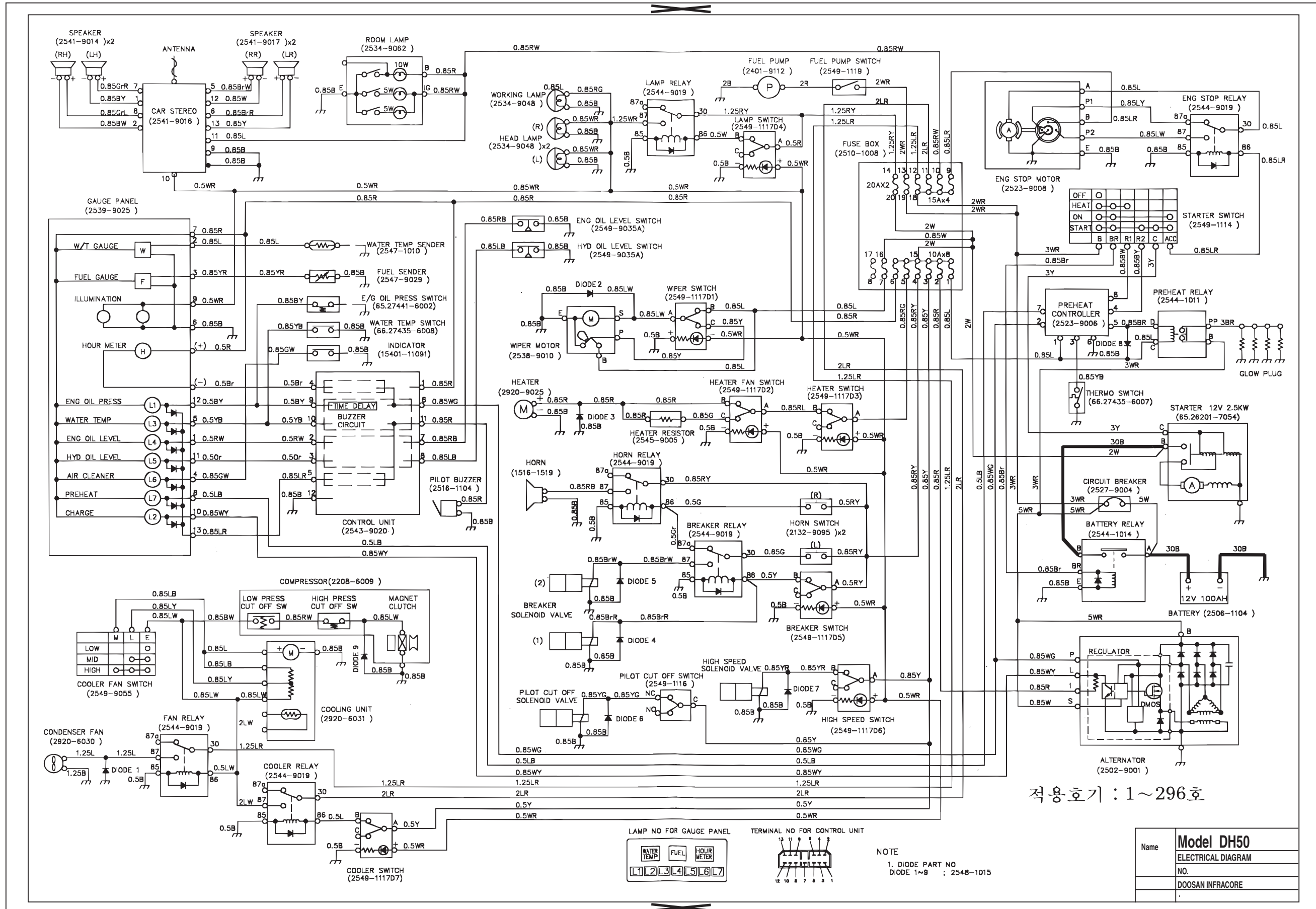

적용호기 : 1~296호

Name	Model DH50
	ELECTRICAL DIAGRAM
	NO.
	DOOSAN INFRACORE

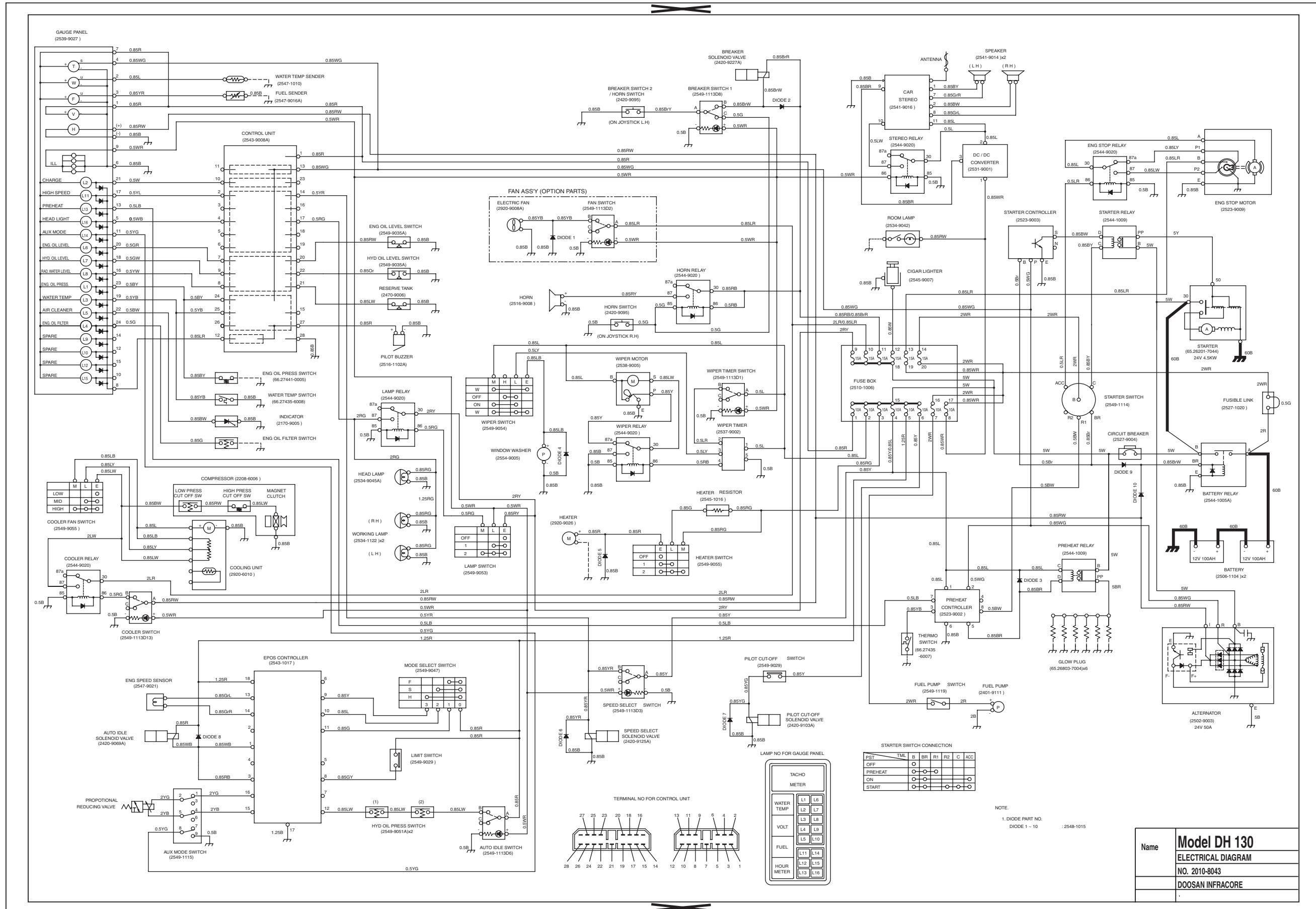

STARTER SWITCH CONNECTION

	PST	TML	B	BR	R1	R2	C	ACC
OFF	○	○	○	○	○	○	○	○
PREHEAT	○	○	○	○	○	○	○	○
ON	○	○	○	○	○	○	○	○
START	○	○	○	○	○	○	○	○

NOTE:
1. DIODE PART NO. : 2548-1015
DIODE 1 - 10

Name	Model DH 130
	ELECTRICAL DIAGRAM
	NO. 2010-8043
	DOOSAN INFRACORE

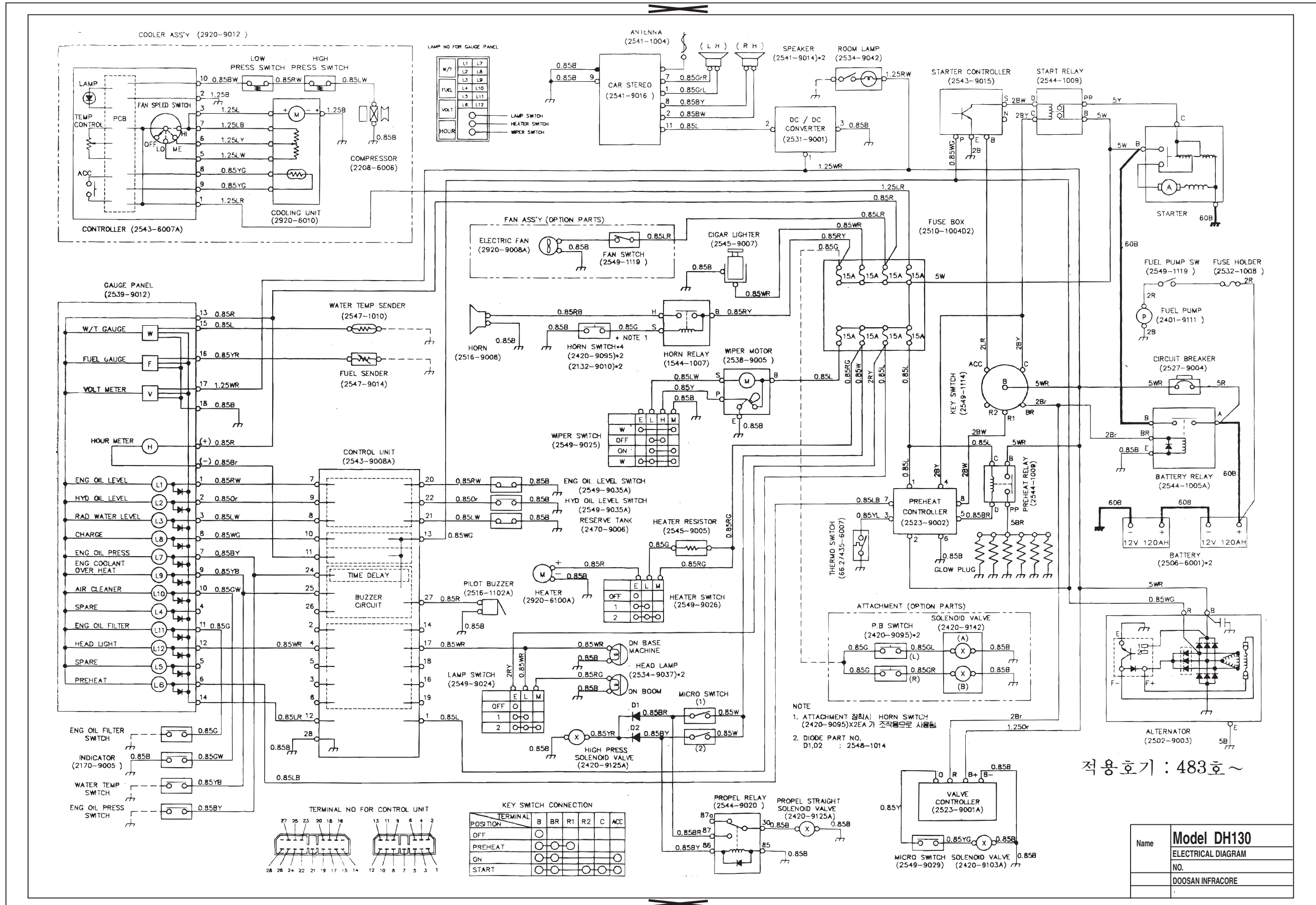

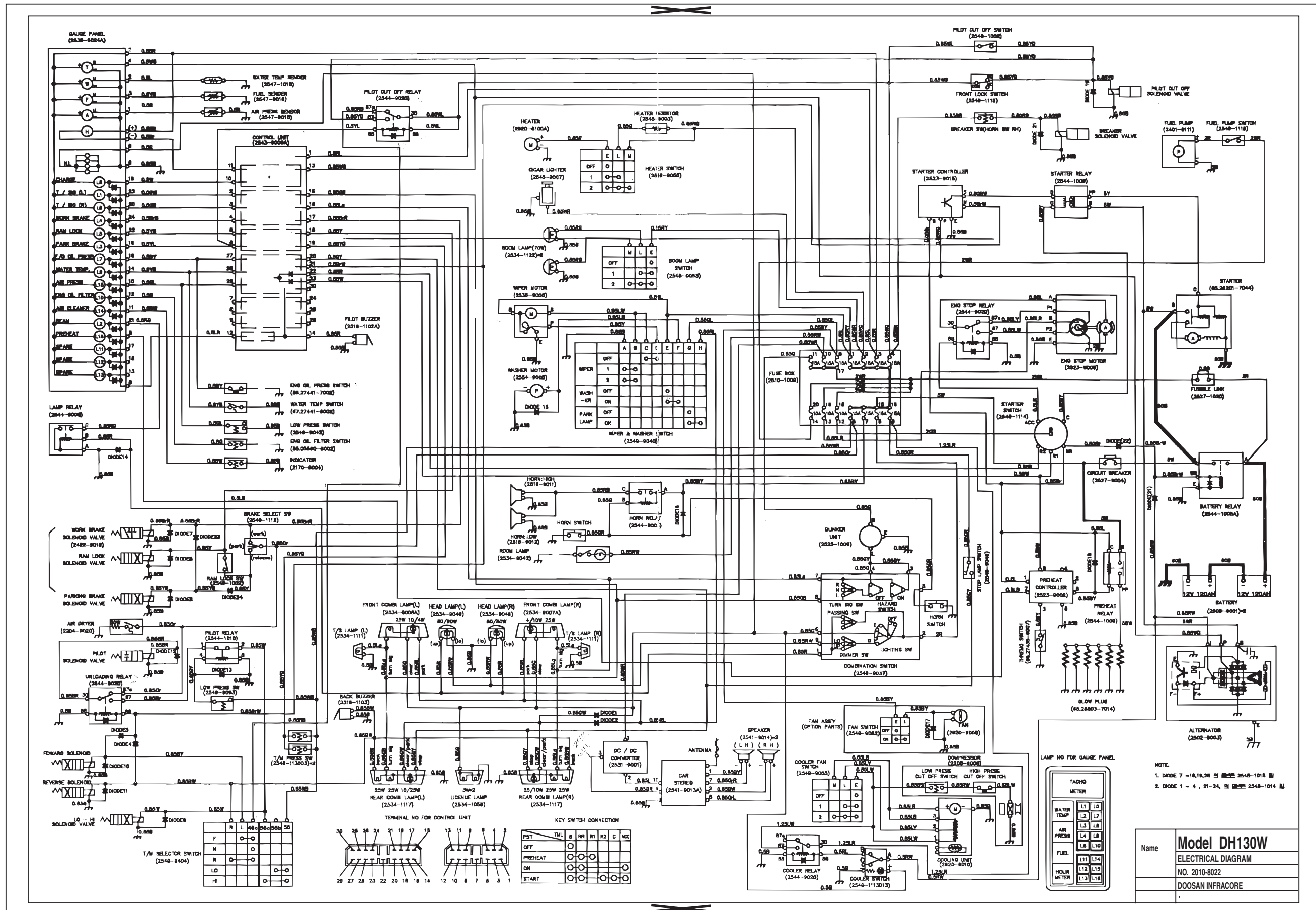

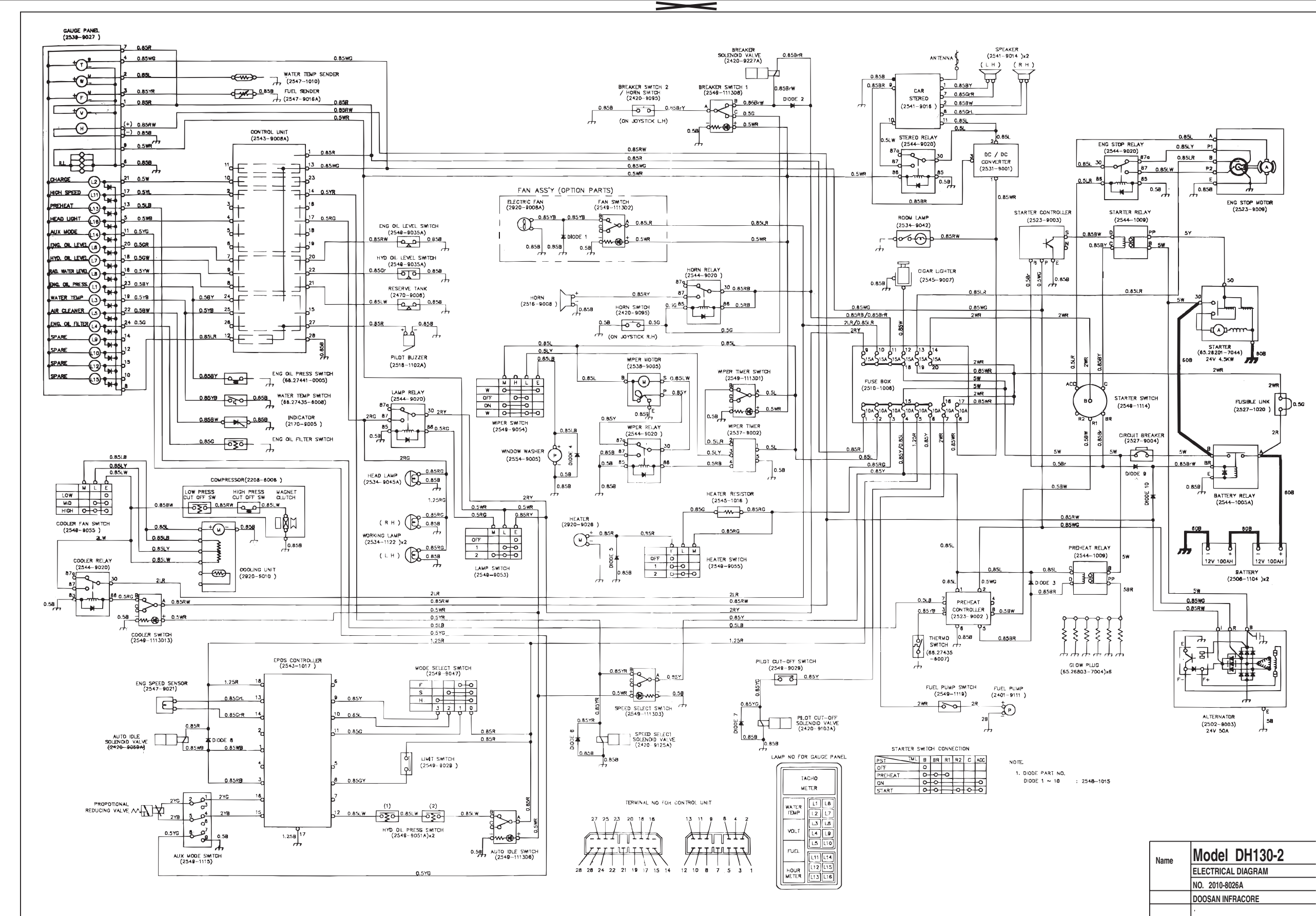

STARTER SWITCH CONNECTION

POS	TL	B	BR	R1	R2	C	ACC
OFF							
PREHEAT							
IGN							
START							

NOTE:
1. DIODE PART NO.
DIODE 1 ~ 10 : 2548-1015

Name	Model DH130-2
	ELECTRICAL DIAGRAM
	NO. 2010-8026A
	DOOSAN INFRACORE

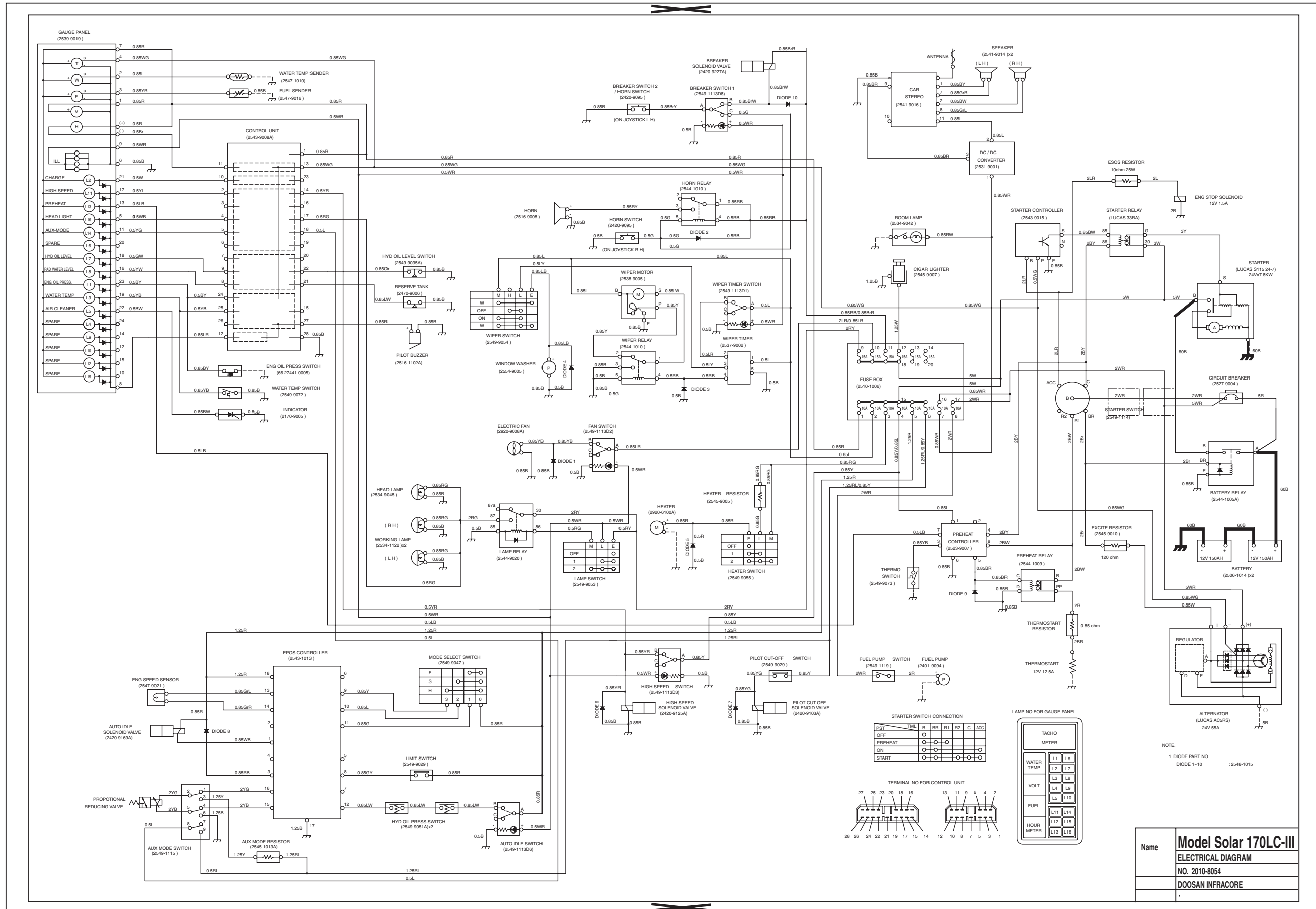

Name	Model Solar 170LC-III
	ELECTRICAL DIAGRAM
	NO. 2010-8054
	DOOSAN INFRACORE

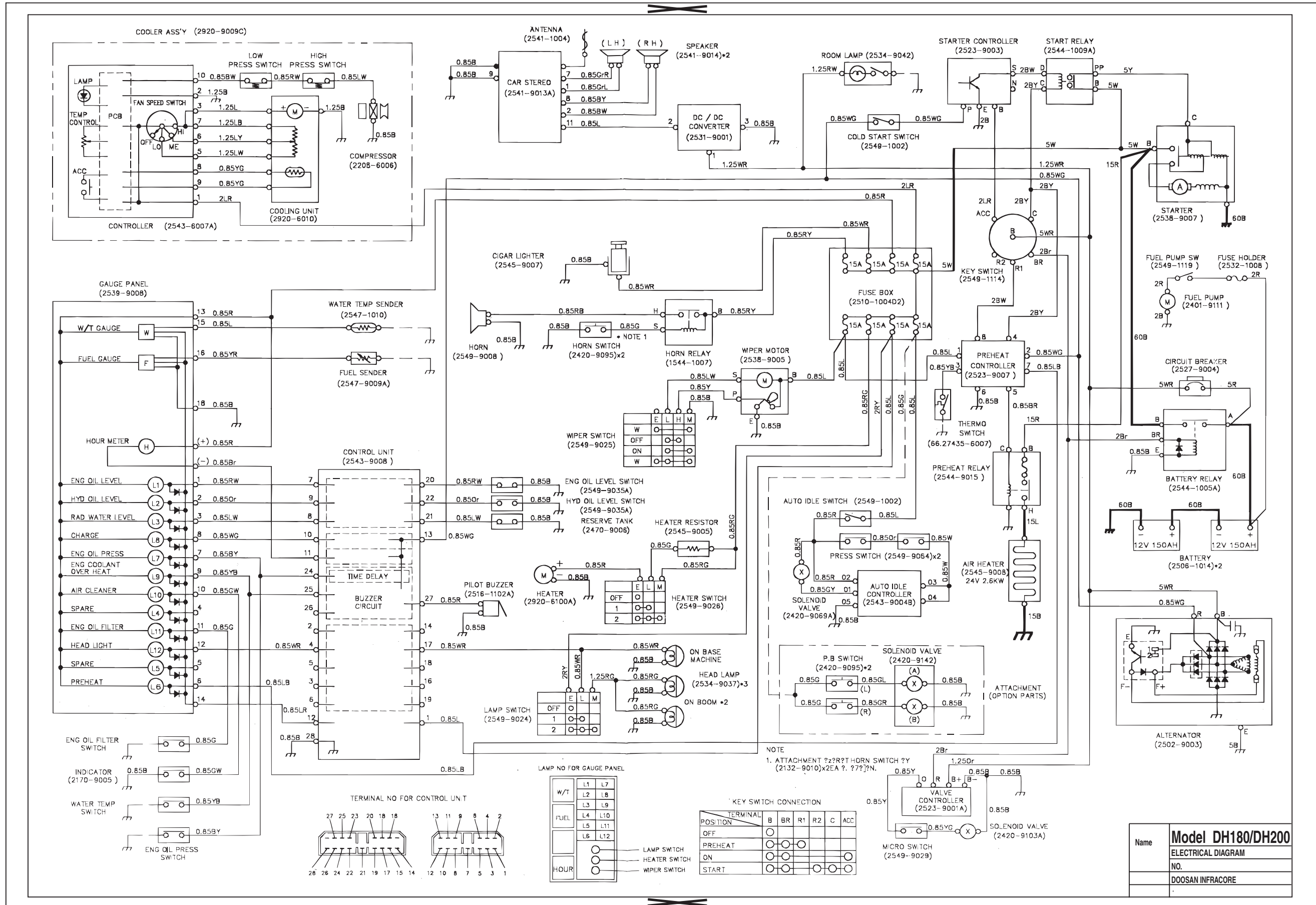

Name **Model DH180/DH200**
 ELECTRICAL DIAGRAM
 NO.
 DOOSAN INFRACORE

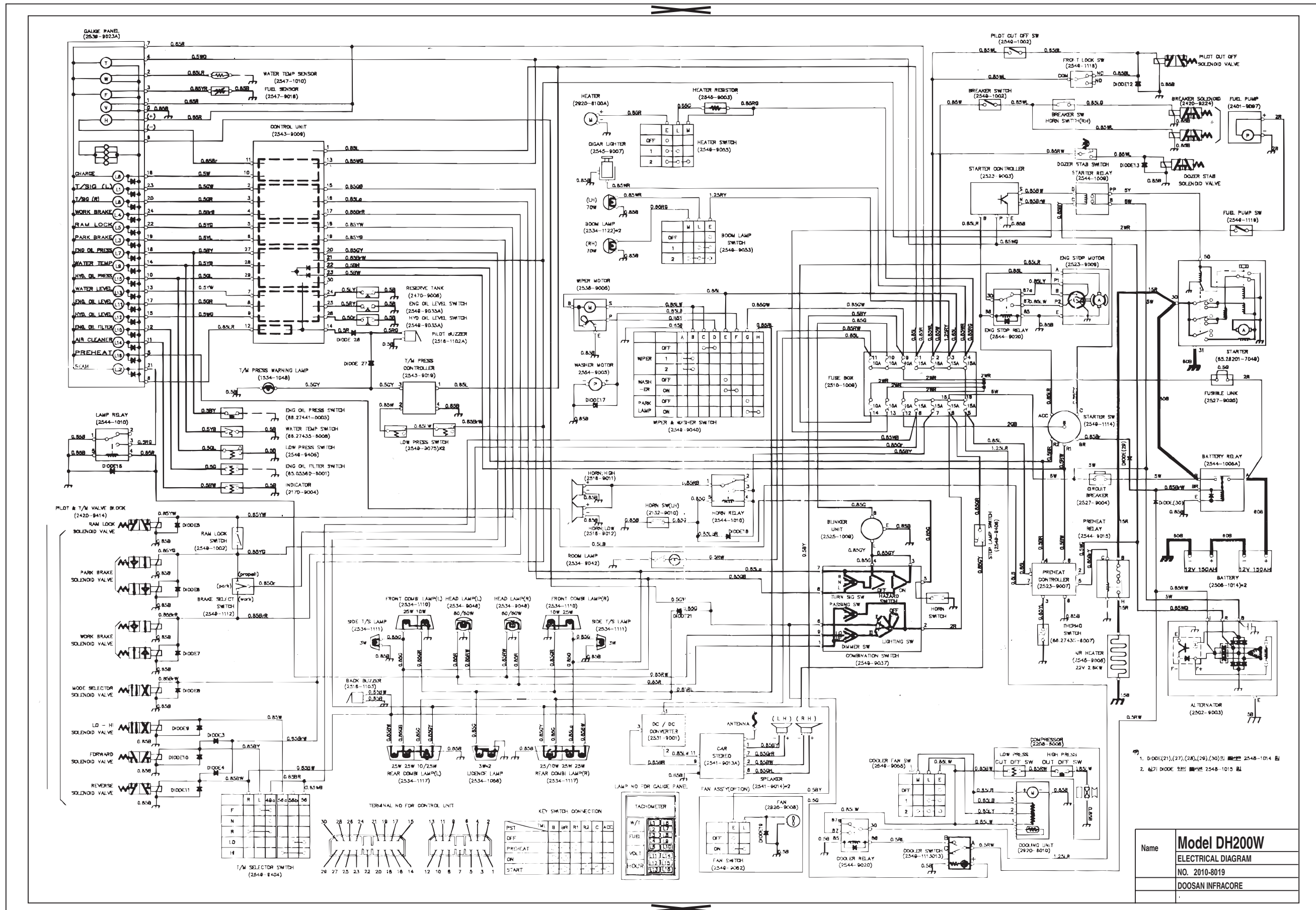

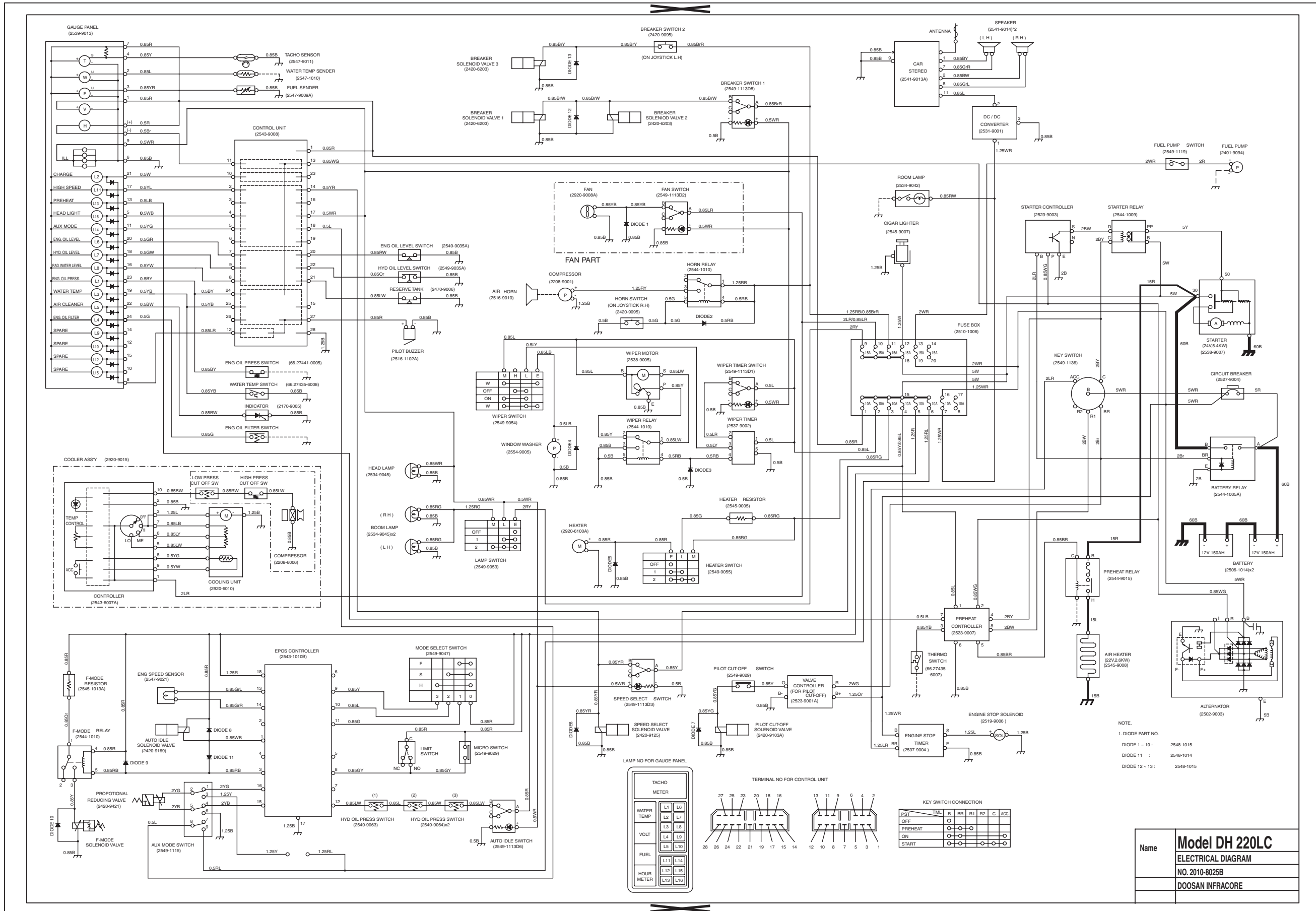

NOTE:
 1. DIODE PART NO.
 DIODE 1 - 10 : 2548-1015
 DIODE 11 : 2548-1014
 DIODE 12 - 13 : 2548-1015

Name	Model DH 220LC
	ELECTRICAL DIAGRAM
	NO. 2010-8025B
	DOOSAN INFRACORE

HAAE0770