

Micro Controller Control System Specification System Operation Testing & Adjusting

**B10R-5, B13R-5, B15R-5, B16R-5
for Electric Lift Truck**

Important Safety Information

Most accidents involving product operation, maintenance and repair are caused by failure to observe basic safety rules or precautions. An accident can often be avoided by recognizing potentially hazardous situations before an accident occurs. A person must be alert to potential hazards. This person should also have the necessary training, skills and tools to perform these functions properly.

Improper operation, lubrication, maintenance or repair of this product can be dangerous and could result in injury or death.

Do not operate or perform any lubrication, maintenance or repair on this product, until you have read and understood the operation, lubrication, maintenance and repair information.

Safety precautions and warnings are provided in this manual and on the product. If these hazard warnings are not heeded, bodily injury or death could occur to you or other persons.

The hazards are identified by the "Safety Alert Symbol" and followed by a "Signal Word" such as "WARNING" as shown below.



The meaning of this safety alert symbol is as follows:

Attention ! Become Alert ! Your Safety is Involved.

The message that appears under the warning, explaining the hazard, can be either written or pictorially presented.

Operations that may cause product damage are identified by NOTICE labels on the product and in this publication.

DOOSAN cannot anticipate every possible circumstance that might involve a potential hazard. The warnings in this publication and on the product are therefore not all inclusive. If a tool, procedure, work method or operating technique not specifically recommended by DOOSAN is used, you must satisfy yourself that it is safe for you and others. You should also ensure that the product will not be damaged or made unsafe by the operation, lubrication, maintenance or repair procedures you choose.

The information, specifications, and illustrations in this publication are on the basis of information available at the time it was written. The specifications, torques, pressures, measurements, adjustments, illustrations, and other items can change at any time. These changes can affect the service given to the product. Obtain the complete and most current information before starting any job. DOOSAN dealers have the most current information available.

Index

Specifications

Component Measurements	5
Controller AS Specification.....	6
Instrument Panel Layout	8
Fuses	9
Assembly Layout of Controller.....	9
Assembly Layout of Motors	9
Control Panel Layout	10

Systems Operation

Glossary	11
General Information	13
Installation and Wiring.....	17

Testing and Adjusting

Preparation Tests and Check.....	23
Programmable Parameters	25
Some Functions Management.....	30

Diagnostic and Troubleshooting

General Description	31
Alarm List	31
Troubleshooting Problem List.....	40
System Tests and Adjustments	82
Electrical System Adjustment.....	83

Instrument Panel

Instrument Panel.....	86
Display Keys Utilization.....	90
Parameter Calibration	91
Sensor Initial Setting.....	94
Default Setting	94
Diagnostic Mode	95
List of diagnostic (Table 9)	96
Accessing Stored Error Codes	97

Eye Software Interface

General Information.....	100
Installation.....	100
Features.....	101
Main Menu	102
Troubleshooting of Eye Program	129

Appendix

Appendix A : Parameter List.....	130
Appendix B : Error Code List	133
Appendix C : Contraction for dot matrix display.	139
F1. Alarm Code	139
F2. Calibration Code.....	140
F3. Diagnostic Code	142

Specifications

Component Measurements

24V

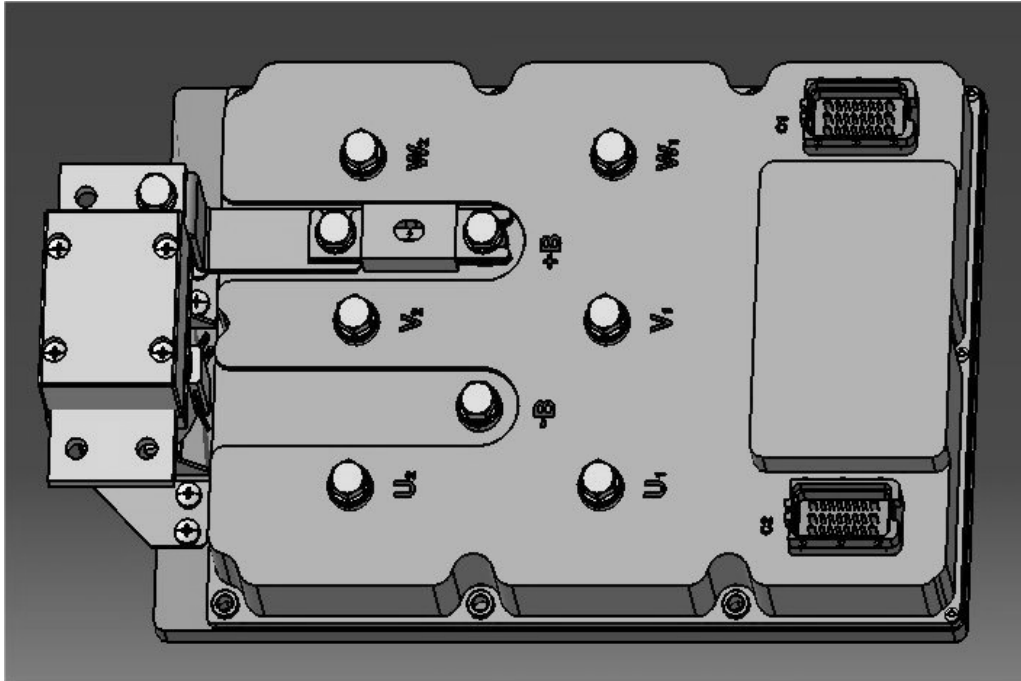

SPECIFICATIONS			
Multimeter Setting	(+) Test Lead	(-) Test Lead	Results
Resistance	+BATT	Each U,V,W	About 1.9 Mohms
Resistance	-BATT	Each U,V,W	About 1.9 Mohms
Resistance	U Terminal	V Terminal	About 4.0 – 5.0 Mohms
Resistance	U Terminal	W Terminal	About 4.0 – 5.0 Mohms
Resistance	V Terminal	W Terminal	About 4.0 – 5.0 Mohms

Controller AS Specification

TYPE	24 V
BATTERY VOLTAGE	12-32 V
MAXIMUM IMPULSIVE DRIVE INVERTER CURRENT	600 A
MAXIMUM IMPULSIVE PUMP INVERTER CURRENT	600 A
SWITCHING FREQUENCY	3-6-9 KHz
EFFICIENCY	95 %
PROTECTION LEVEL	IP65
MECHANICAL SIZE	382x220x123
WEIGHT	6.5 Kg
VIBRATION	5g 10-500Hz in X,Y,Z axis
TEMPERATURE RANGE	- 30 °C , + 40 °C
MAXIMUM MODULE TEMPERATURE	100°C
CONTROLLER	Complies with EN 1175-1 EN 12895-1
MAIN CONTACTOR	600A
MAIN FUSE	700A
KEY FUSE	10A

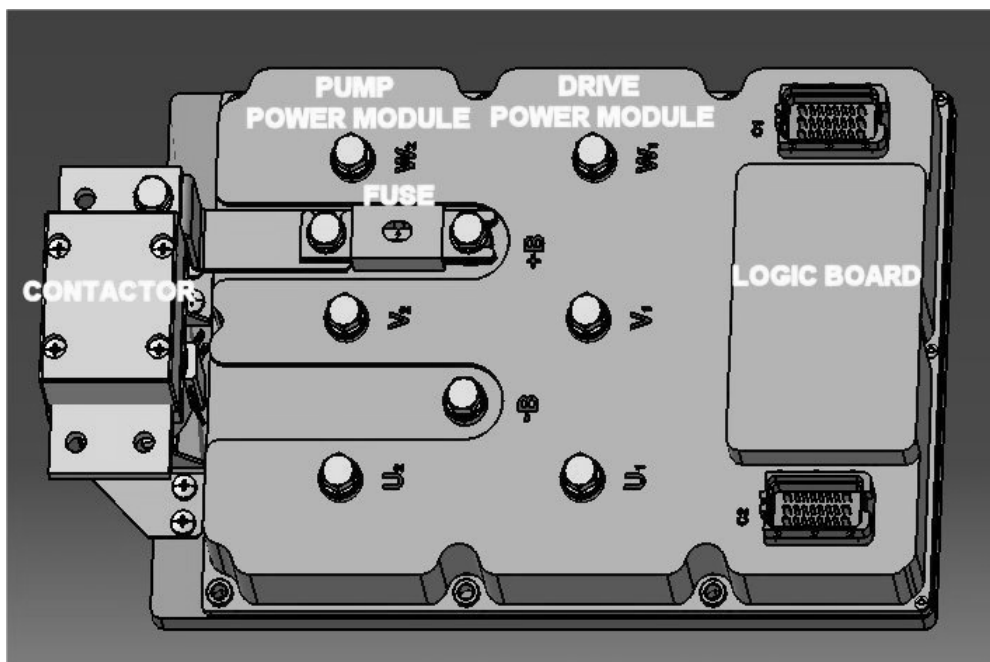

Drive Motor Specification

TYPE	24 V
POWER	5 KW
VOLTAGE	16 V
CURRENT	240 A
RATED SPEED	1866 RPM
MAXIMUM SPEED	4500 RPM
FREQUENCY	65 Hz
Cos ϕ	0.874
SERVICE	S2 60'
INSULATION CLASS	F
PROTECTION DEGREE	IP 22
BEARINGS	6208 2RS
WEIGHT	32 Kg

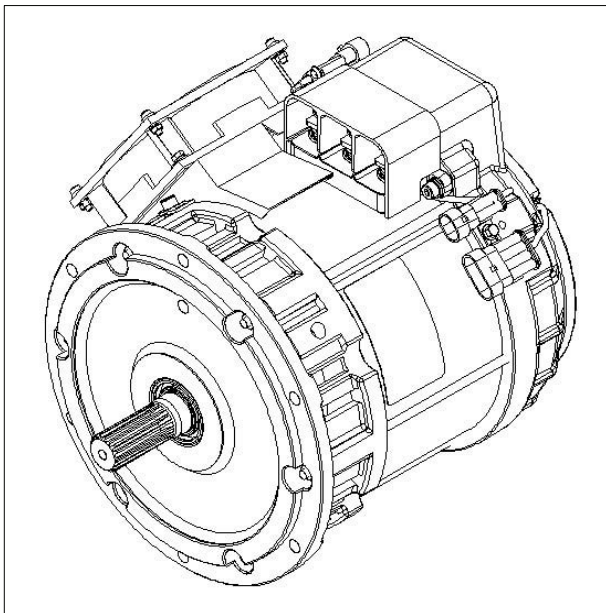

Pump Motor Specification

TYPE	24 V
POWER	7 KW
VOLTAGE	16 V
CURRENT	335 A
RATED SPEED	1550 RPM
MAXIMUM SPEED	4500 RPM
FREQUENCY	55 Hz
Cos ϕ	0.902
SERVICE	S3 15%
INSULATION CLASS	F
PROTECTION DEGREE	IP 22
BEARINGS	6208 2RS
WEIGHT	32 Kg

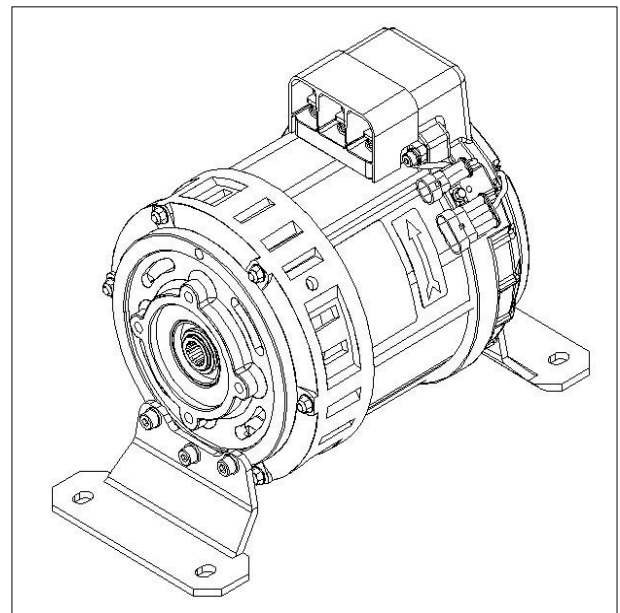

Instrument Panel Layout

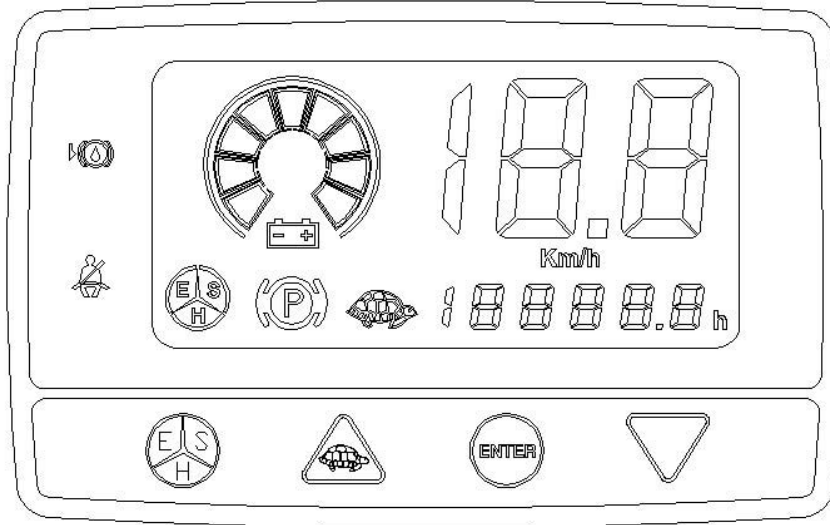

(STANDARD)

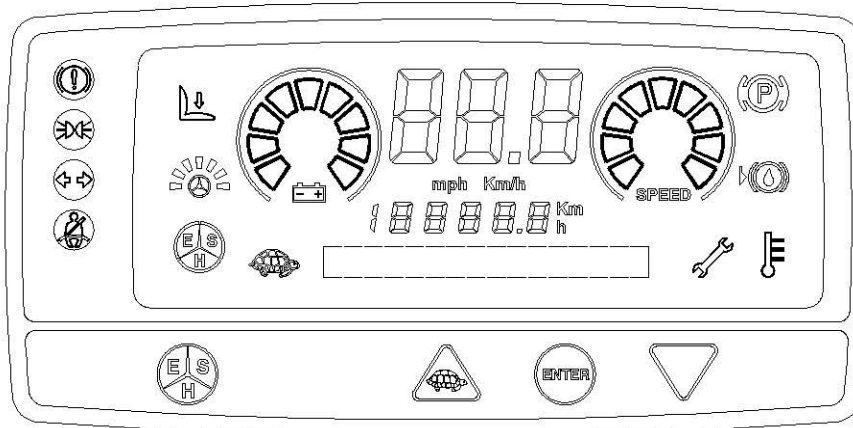

(OPTION)
