

GROUP TAB LOCATOR
-------------------

Introduction	
0 Lubrication & Maintenance	
2 Suspension	
3 Differential & Driveline	
5 Brakes	
6 Clutch	
7 Cooling	
8A Audio	
8B Chime/Buzzer	
8E Electronic Control Modules	
8F Engine Systems	
8G Heated Systems	
8H Horn	
8I Ignition Control	
8J Instrument Cluster	
8L Lamps	
8M Message Systems	
8N Power Systems	
8O Restraints	
8P Speed Control	
8Q Vehicle Theft Security	
8R Wipers/Washers	
8W Wiring	
9 Engine	
11 Exhaust System	
13 Frame & Bumpers	
14 Fuel System	
19 Steering	
21 Transmission and Transfer Case	
22 Tires/Wheels	
23 Body	
24 Heating & Air Conditioning	
25 Emissions Control	
Component and System Index	

<b>Service Manual Comment Forms</b>	<b>(Rear of Manual)</b>
-------------------------------------	-------------------------

# INTRODUCTION

## TABLE OF CONTENTS

	page		page
<b>VEHICLE SAFETY CERTIFICATION LABEL</b>		<b>FASTENER IDENTIFICATION</b>	
DESCRIPTION .....	1	DESCRIPTION .....	6
<b>VEHICLE IDENTIFICATION NUMBER</b>		<b>FASTENER USAGE</b>	
DESCRIPTION .....	2	DESCRIPTION - FASTENER USAGE .....	9
<b>VEHICLE EMISSION CONTROL INFORMATION (VECI)</b>		<b>THREADED HOLE REPAIR</b>	
DESCRIPTION .....	3	DESCRIPTION - THREADED HOLE REPAIR ....	9
<b>BODY CODE PLATE</b>		<b>METRIC SYSTEM</b>	
DESCRIPTION .....	4	DESCRIPTION .....	9
<b>INTERNATIONAL VEHICLE CONTROL &amp; DISPLAY SYMBOLS</b>		<b>TORQUE REFERENCES</b>	
DESCRIPTION - INTERNATIONAL SYMBOLS ...	6	DESCRIPTION .....	11

## VEHICLE SAFETY CERTIFICATION LABEL

### DESCRIPTION

A vehicle safety certification label (Fig. 1) is attached to every DaimlerChrysler Corporation vehicle. The label certifies that the vehicle conforms to all applicable Federal Motor Vehicle Safety Standards. The label also lists:

- Month and year of vehicle manufacture.
- Gross Vehicle Weight Rating (GVWR). The gross front and rear axle weight ratings (GAWR's) are based on a minimum rim size and maximum cold tire inflation pressure.
- Vehicle Identification Number (VIN).
- Type of vehicle.
- Type of rear wheels.
- Bar code.
- Month, Day and Hour (MDH) of final assembly.
- Paint and Trim codes.
- Country of origin.

The label is located on the driver-side door shut-face.

MFD BY	DAIMLER CHRYSLER CORPORATION	DATE OF MFR	1-96 C	GVWR	2268 KG (05000 LB)
GAWR FRONT	1203 KG (2650 LB)	WITH TIRES	P195/75R14	RIMS AT	14 X 5.5
GAWR REAR	1225 KG (2700 LB)	WITH TIRES	P195/75R14	RIMS AT	14 X 5.5
				COLD	380 KPA(35 PSI)
				COLD	380 KPA(35 PSI)
THIS VEHICLE CONFORMS TO ALL APPLICABLE FEDERAL MOTOR VEHICLE SAFETY STANDARDS IN EFFECT ON THE DATE OF MANUFACTURE SHOWN ABOVE.					
VIN:	XXXXXXXXXXXXXXXXXX	TYPE:	SINGLE X DUAL		
					
MDH:	010615 021	PAINT:POP	VEHICLE MADE IN CANADA	TRIM:C5C3	4848505

8086dl7b

**Fig. 1 VEHICLE SAFETY CERTIFICATION LABEL - TYPICAL**

# VEHICLE IDENTIFICATION NUMBER

## DESCRIPTION

### VIN CODING/LOCATIONS

The Vehicle Identification Number (VIN) plate is located on the lower windshield fence near the left a-pillar (Fig. 2). The VIN contains 17 characters that provide data concerning the vehicle. Refer to the VIN decoding chart to determine the identification of a vehicle.

The VIN is also imprinted on the:

- Body Code Plate.
- Equipment Identification Plate.
- Vehicle Safety Certification Label.
- Frame rail.

To protect the consumer from theft and possible fraud the manufacturer is required to include a Check Digit at the ninth position of the VIN. The check digit is used by the manufacturer and government agencies to verify the authenticity of the vehi-

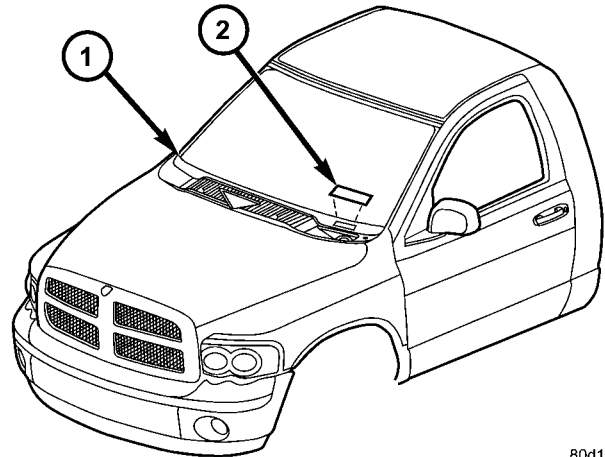

80d18710

**Fig. 2 VIN LOCATION**

- 1 - DASH PANEL
- 2 - VIN CODE PLATE

cle and official documentation. The formula to use the check digit is not released to the general public.

POSITION	INTERPRETATION	CODE = DESCRIPTION
1	Country of Origin	1 = Manufactured By DaimlerChrysler Corporation 3 = Manufactured By DaimlerChrysler De Mexico
2	Make	D = Dodge
3	Vehicle Type	2 = Incomplete with Side Airbag 3 = Truck with Side Airbag 6 = Incomplete Less Side Airbag 7 = Truck Less Side Airbag
4	Gross Vehicle Weight Rating	G = 5,001-6000 lbs. H = 6,001-7,000 lbs. J = 7,001-8,000 lbs. K = 8,001-9,000 lbs. L = 9,001-10,000 lbs. M = 10,001-14,000 lbs. W = Buses/Incomplete Vehicles with Hydraulic Brakes
5	Vehicle Line	A = Ram Pickup 4X2 U = Ram Pickup 4X4
6	Series	1 = 1500 2 = 2500 3 = 3500 Less Dual Rear Wheels 4 = 3500 With Dual Rear Wheels
7	Body Style	6 = Conventional Cab 8 = Quad Cab Full Rear Doors

VEHICLE IDENTIFICATION NUMBER (Continued)

POSITION	INTERPRETATION	CODE = DESCRIPTION
8	Engine	K = 3.7L 6 cyl. MPI Gasoline N = 4.7L 8 cyl. MPI Gasoline D = 5.7L 8 cyl. SMPI Gasoline 6 = 5.9L 6 cyl. Turbo Diesel C = 5.9L 6 cyl. Turbo Diesel High Output W = 8.0L 10 cyl. MPI Gasoline Z = 5.9L 8 cyl. SMPI Gasoline Light Duty
9	Check Digit	0 through 9 or X
10	Model Year	3 = 2003
11	Plant Location	S = Dodge City G = Saltillo J = St. Louis (North)
12 thru 17	Vehicle Build Sequence	

VEHICLE EMISSION CONTROL INFORMATION (VECI)

DESCRIPTION

All models have a Vehicle Emission Control Information (VECI) Label. DaimlerChrysler permanently attaches the label in the engine compartment (Fig. 3). The label cannot be removed without defacing label information and destroying label.

The label contains the vehicle's emission specifications and vacuum hose routings. All hoses must be connected and routed according to the label.

The label also contains an engine vacuum schematic. There are unique labels for vehicles built for sale in the state of California and the country of Canada. Canadian labels are written in both the English and French languages.

The VECI label contains the following:

- Engine family and displacement
- Evaporative family
- Emission control system schematic
- Certification application
- Engine timing specifications (if adjustable)
- Idle speeds (if adjustable)
- Spark plug and gap

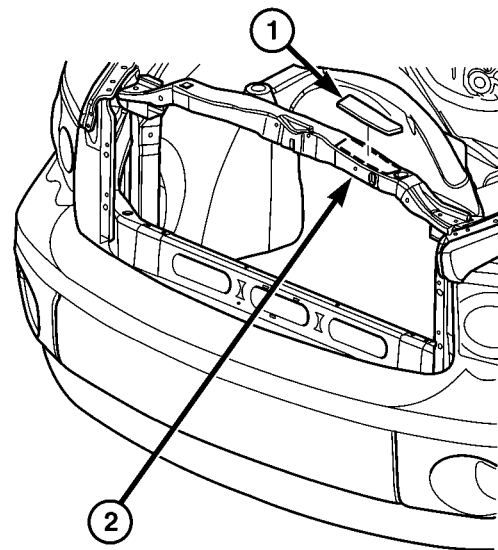

80cd9d69

**Fig. 3 VEHICLE EMISSIONS CERTIFICATION INFORMATION LABEL**

- 1 - VECI LABEL LOCATION
- 2 - RADIATOR SUPPORT

# BODY CODE PLATE

## DESCRIPTION

The Body Code Plate (Fig. 5) is located on the right front hydroform fender rail just behind the headlight assembly (Fig. 4). There are seven lines of information on the body code plate. Lines 5, 6, and 7 are not used to define service information. Information reads from left to right, starting with line 4 in the center of the plate to line 1 at the bottom of the plate.

The last code imprinted on a vehicle code plate will be followed by the imprinted word END. When two vehicle code plates are required, the last available spaces on the first plate will be imprinted with the letters CTD (for continued).

When a second vehicle code plate is necessary, the first four spaces on each row will not be used because of the plate overlap.

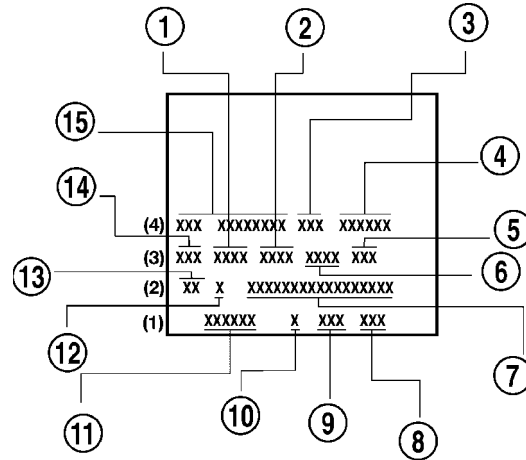

80b6b368

**Fig. 5 BODY CODE PLATE**

- 1 - PRIMARY PAINT
- 2 - SECONDARY PAINT
- 3 - TRANSMISSION CODE
- 4 - VEHICLE MODEL NUMBER
- 5 - ENGINE CODE
- 6 - INTERIOR TRIM CODE
- 7 - VEHICLE IDENTIFICATION NUMBER
- 8 - TAILGATE CODE
- 9 - CARGO BOX CODE
- 10 - TAILGATE TRIM CODE
- 11 - BODY-IN-WHITE SEQUENCE
- 12 - MARKET CODE
- 13 - SPECIES CODE
- 14 - PAINT PROCEDURE
- 15 - VEHICLE ORDER NUMBER

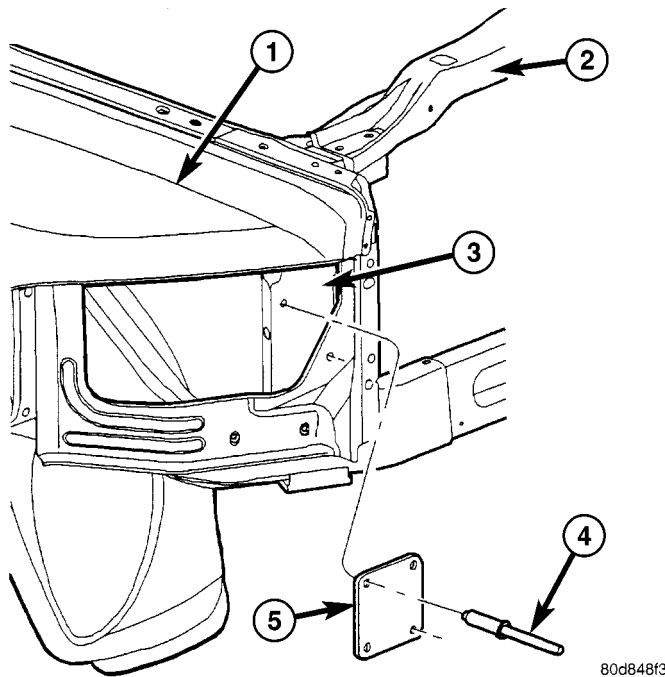

80d848f3

**Fig. 4 BODY CODE PLATE LOCATION**

- 1 - FENDER
- 2 - RADIATOR CROSSMEMBER
- 3 - HYDROFORM FENDER RAIL
- 4 - RIVOT (2)
- 5 - BODY CODE PLATE

## BODY CODE PLATE—LINE 4

### DIGITS 1 THROUGH 12

Vehicle Order Number

### DIGITS 13, 14, AND 15

#### Transmission Codes

- DGT = 4-speed Automatic (46RE)
- DG4 = 4-speed Automatic (45RFE)
- DGP = 4-speed Automatic (47RE)
- DG8 = 4-speed Automatic (48RE)
- DDC = 5-speed Manual (NV3500)
- DDP = 5-speed Manual (NV4500)
- DEE = 6-speed Manual (NV5600)

### DIGITS 16, 17, AND 18

#### Car Line Shell

- DR1 = 1500 4 X 2
- DR6 = 1500 4 X 4
- DR2 = 2500 4 X 2
- DR7 = 2500 4 X 4
- DR3 = 3500 4 X 2
- DR8 = 3500 4 X 4

## BODY CODE PLATE (Continued)

## DIGIT 19

## Price Class

- L = Low
- H = Highline

## DIGITS 20 AND 21

## Body Type

- 41 = Ram Truck Quad Cab, Short Box
- 42 = Ram Truck Quad Cab, Long Box
- 61 = Ram Truck Standard Cab, Short Box
- 62 = Ram Truck Standard Cab, Long Box

## BODY CODE PLATE—LINE 3

## DIGITS 1,2, AND 3

## Paint Procedure

- APA = Monotone
- AP9 = Special
- APD = Two-tone (Lower break)

## DIGIT 4

Open Space

## DIGITS 5 THROUGH 8

## Primary Paint

(Refer to 23 - BODY/PAINT - SPECIFICATIONS)  
for color codes.

## DIGIT 9

Open Space

## DIGITS 10 THROUGH 13

Secondary Paint

## DIGIT 14

Open Space

## DIGITS 15 THROUGH 18

Interior Trim Code

## DIGIT 19

Open Space

## DIGITS 20, 21, AND 22

## Engine Code

- EKG = 3.7 L 6 cyl. MPI Gasoline
- EVA = 4.7 L 8 cyl. MPI Gasoline
- EZA = 5.7 L 8 cyl. SMPI Gasoline
- EML = 5.9 L 8 cyl. SMPI Gasoline
- ETC = 5.9 L 6 cyl. Cummins Turbo Diesel
- ETH = 5.9 L 6 cyl. Cummins Turbo Diesel High

## Output

- EWA = 8.0 L 10 cyl. MPI Gasoline

## BODY CODE PLATE—LINE 2

DIGIT 1 Open Space

DIGITS 2 AND 3 Species Code. (Used for Manufacturing)

## DIGIT 4

Open Space

## DIGIT 5

## Market Code

- B = International
- C = Canada
- M = Mexico
- U = United States

## DIGIT 6

Open Space

## DIGITS 7 THROUGH 23

## Vehicle Identification Number (VIN)

(Refer to VEHICLE DATA/VEHICLE INFORMATION/VEHICLE IDENTIFICATION NUMBER - DESCRIPTION) for proper breakdown of VIN code.

## BODY CODE PLATE—LINE 1

DIGITS 1 THROUGH 6 Body-in-white assembly sequence.

## DIGIT 7

Open Space

DIGIT 8 Tailgate trim code.

## DIGIT 9

Open Space

DIGITS 10 THROUGH 12 Cargo box code

## DIGIT 13

Open Space

DIGITS 14 THROUGH 16 Tailgate code

## INTERNATIONAL VEHICLE CONTROL & DISPLAY SYMBOLS

























### DESCRIPTION - INTERNATIONAL SYMBOLS

The graphic symbols illustrated in the following International Control and Display Symbols Chart are used to identify various instrument controls. The symbols correspond to the controls and displays that are located on the instrument panel.

## FASTENER IDENTIFICATION

### DESCRIPTION

The SAE bolt strength grades range from grade 2 to grade 8. The higher the grade number, the greater the bolt strength. Identification is determined by the line marks on the top of each bolt head. The actual bolt strength grade corresponds to the number of line marks plus 2. The most commonly used metric bolt strength classes are 9.8 and 10.9. The metric strength class identification number is imprinted on the head of the bolt. The higher the class number, the greater the bolt strength. Some metric nuts are imprinted with a single-digit strength class on the nut face. Refer to the Fastener Identification and Fastener Strength Charts (Fig. 6) and (Fig. 7).

 1	 2	 3	 4	 5	 6
 7	 8	 9	 10	 11	 12
 13	 14	 15	 16	 17	 18
 19	 20	 21	 22	 23	 24

80be4788

### INTERNATIONAL SYMBOLS

1	High Beam	13	Rear Window Washer
2	Fog Lamps	14	Fuel
3	Headlamp, Parking Lamps, Panel Lamps	15	Engine Coolant Temperature
4	Turn Warning	16	Battery Charging Condition
5	Hazard Warning	17	Engine Oil
6	Windshield Washer	18	Seat Belt
7	Windshield Wiper	19	Brake Failure
8	Windshield Wiper and Washer	20	Parking Brake
9	Windscreen Demisting and Defrosting	21	Front Hood
10	Ventilating Fan	22	Rear hood (Decklid)
11	Rear Window Defogger	23	Horn
12	Rear Window Wiper	24	Lighter

FASTENER IDENTIFICATION (Continued)

**Bolt Markings and Torque - Metric**

Commercial Steel Class

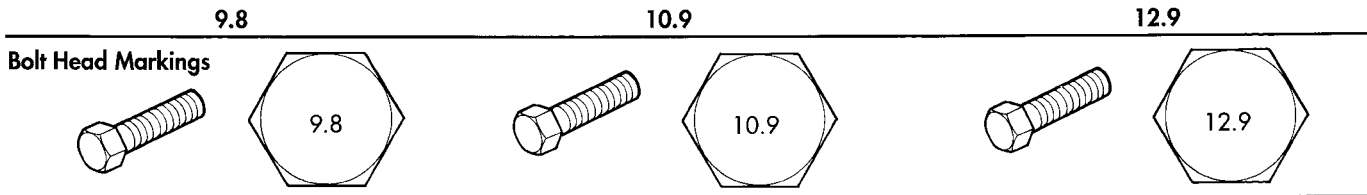

Body Size	9.8				10.9				12.9			
	Torque		Torque		Torque		Torque		Torque		Torque	
	Diam.	Cast Iron	Aluminum	Cast Iron	Aluminum	Cast Iron	Aluminum	Cast Iron	Aluminum	Cast Iron	Aluminum	
mm	N•m	ft-lb	N•m	ft-lb	N•m	ft-lb	N•m	ft-lb	N•m	ft-lb	N•m	ft-lb
6	9	5	7	4	14	9	11	7	14	9	11	7
7	14	9	11	7	18	14	14	11	23	18	18	14
8	25	18	18	14	32	23	25	18	36	27	28	21
10	40	30	30	25	60	45	45	35	70	50	55	40
12	70	55	55	40	105	75	80	60	125	95	100	75
14	115	85	90	65	160	120	125	95	195	145	150	110
16	180	130	140	100	240	175	190	135	290	210	220	165
18	230	170	180	135	320	240	250	185	400	290	310	230

**Bolt Markings and Torque Values - U.S. Customary**

SAE Grade Number









Body Size	Bolt Torque - Grade 5 Bolt				Bolt Torque - Grade 8 Bolt			
	Cast Iron		Aluminum		Cast Iron		Aluminum	
	N•m	ft-lb	N•m	ft-lb	N•m	ft-lb	N•m	ft-lb
1/4 - 20	9	7	8	6	15	11	12	9
- 28	12	9	9	7	18	13	14	10
5/16 - 18	20	15	16	12	30	22	24	18
- 24	23	17	19	14	33	24	25	19
3/8 - 16	40	30	25	20	55	40	40	30
- 24	40	30	35	25	60	45	45	35
7/16 - 14	60	45	45	35	90	65	65	50
- 20	65	50	55	40	95	70	75	55
1/2 - 13	95	70	75	55	130	95	100	75
- 20	100	75	80	60	150	110	120	90
9/16 - 12	135	100	110	80	190	140	150	110
- 18	150	110	115	85	210	155	170	125
5/8 - 11	180	135	150	110	255	190	205	150
- 18	210	155	160	120	290	215	230	170
3/4 - 10	325	240	255	190	460	340	365	270
- 16	365	270	285	210	515	380	410	300
7/8 - 9	490	360	380	280	745	550	600	440
- 14	530	390	420	310	825	610	660	490
1 - 8	720	530	570	420	1100	820	890	660
- 14	800	590	650	480	1200	890	960	710

Fig. 6 FASTENER IDENTIFICATION

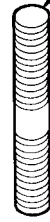

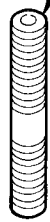
FASTENER IDENTIFICATION (Continued)

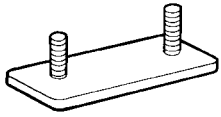
HOW TO DETERMINE BOLT STRENGTH

	Mark	Class		Mark	Class
Hexagon head bolt	 <p>Bolt head No.</p> <p>4 — 4T 5 — 5T 6 — 6T 7 — 7T 8 — 8T 9 — 9T 10 — 10T 11 — 11T</p>		Stud bolt	 <p>No mark</p>	4T
	 <p>No mark</p>	4T			
Hexagon flange bolt w/washer hexagon bolt	 <p>No mark</p>	4T		 <p>Grooved</p>	6T
Hexagon head bolt	 <p>Two protruding lines</p>	5T			
Hexagon flange bolt w/washer hexagon bolt	 <p>Two protruding lines</p>	6T	Welded bolt		4T
Hexagon head bolt	 <p>Three protruding lines</p>	7T			
Hexagon head bolt	 <p>Four protruding lines</p>	8T			

95IN-4

Fig. 7 FASTENER STRENGTH

## FASTENER USAGE

### DESCRIPTION - FASTENER USAGE

**WARNING: USE OF AN INCORRECT FASTENER MAY RESULT IN COMPONENT DAMAGE OR PERSONAL INJURY.**

Fasteners and torque specifications references in this Service Manual are identified in metric and SAE format.

During any maintenance or repair procedures, it is important to salvage all fasteners (nuts, bolts, etc.) for reassembly. If the fastener is not salvageable, a fastener of equivalent specification must be used.

## THREADED HOLE REPAIR

### DESCRIPTION - THREADED HOLE REPAIR

Most stripped threaded holes can be repaired using a Helicoil®. Follow the vehicle or Helicoil® recommendations for application and repair procedures.

## METRIC SYSTEM

### DESCRIPTION

The metric system is based on quantities of one, ten, one hundred, one thousand and one million.

The following chart will assist in converting metric units to equivalent English and SAE units, or vice versa.

### CONVERSION FORMULAS AND EQUIVALENT VALUES

MULTIPLY	BY	TO GET	MULTIPLY	BY	TO GET
in-lbs	x 0.11298	= Newton Meters (N·m)	N·m	x 8.851	= in-lbs
ft-lbs	x 1.3558	= Newton Meters (N·m)	N·m	x 0.7376	= ft-lbs
Inches Hg (60° F)	x 3.377	= Kilopascals (kPa)	kPa	x 0.2961	= Inches Hg
psi	x 6.895	= Kilopascals (kPa)	kPa	x 0.145	= psi
Inches	x 25.4	= Millimeters (mm)	mm	x 0.03937	= Inches
Feet	x 0.3048	= Meters (M)	M	x 3.281	= Feet
Yards	x 0.9144	= Meters	M	x 1.0936	= Yards
mph	x 1.6093	= Kilometers/Hr. (Km/h)	Km/h	x 0.6214	= mph
Feet/Sec	x 0.3048	= Meters/Sec (M/S)	M/S	x 3.281	= Feet/Sec
mph	x 0.4470	= Meters/Sec (M/S)	M/S	x 2.237	= mph
Kilometers/Hr. (Km/h)	x 0.27778	= Meters/Sec (M/S)	M/S	x 3.600	Kilometers/Hr. (Km/h)

### COMMON METRIC EQUIVALENTS

1 inch = 25 Millimeters	1 Cubic Inch = 16 Cubic Centimeters
1 Foot = 0.3 Meter	1 Cubic Foot = 0.03 Cubic Meter
1 Yard = 0.9 Meter	1 Cubic Yard = 0.8 Cubic Meter
1 Mile = 1.6 Kilometers	

Refer to the Metric Conversion Chart to convert torque values listed in metric Newton- meters (N·m). Also, use the chart to convert between millimeters (mm) and inches (in.) (Fig. 8).

METRIC SYSTEM (Continued)

in-lbs to N•m

N•m to in-lbs

in-lb	N•m	in-lb	N•m	in-lb	N•m	in-lb	N•m	in-lb	N•m	N•m	in-lb	N•m	in-lb	N•m	in-lb	N•m	in-lb	N•m	in-lb	N•m
2	.2260	42	4.7453	82	9.2646	122	13.7839	162	18.3032	.2	1.7702	4.2	37.1747	8.2	72.5792	12.2	107.9837	16.2	143.3882	
4	.4519	44	4.9713	84	9.4906	124	14.0099	164	18.5292	.4	3.5404	4.4	38.9449	8.4	74.3494	12.4	109.7539	16.4	145.1584	
6	.6779	46	5.1972	86	9.7165	126	14.2359	166	18.7552	.6	5.3107	4.6	40.7152	8.6	76.1197	12.6	111.5242	16.6	146.9287	
8	.9039	48	5.4232	88	9.9425	128	14.4618	168	18.9811	.8	7.0809	4.8	42.4854	8.8	77.8899	12.8	113.2944	16.8	148.6989	
10	1.1298	50	5.6492	90	10.1685	130	14.6878	170	19.2071	1	8.8511	5	44.2556	9	79.6601	13	115.0646	17	150.4691	
12	1.3558	52	5.8751	92	10.3944	132	14.9138	172	19.4331	1.2	10.6213	5.2	46.0258	9.2	81.4303	13.2	116.8348	17.2	152.2393	
14	1.5818	54	6.1011	94	10.6204	134	15.1397	174	19.6590	1.4	12.3916	5.4	47.7961	9.4	83.2006	13.4	118.6051	17.4	154.0096	
16	1.8077	56	6.3270	96	10.8464	136	15.3657	176	19.8850	1.6	14.1618	5.6	49.5663	9.6	84.9708	13.6	120.3753	17.6	155.7798	
18	2.0337	58	6.5530	98	11.0723	138	15.5917	178	20.1110	1.8	15.9320	5.8	51.3365	9.8	86.7410	13.8	122.1455	17.8	157.5500	
20	2.2597	60	6.7790	100	11.2983	140	15.8176	180	20.3369	2	17.7022	6	53.1067	10	88.5112	14	123.9157	18	159.3202	
22	2.4856	62	7.0049	102	11.5243	142	16.0436	182	20.5629	2.2	19.4725	6.2	54.8770	10.2	90.2815	14.2	125.6860	18.5	163.7458	
24	2.7116	64	7.2309	104	11.7502	144	16.2696	184	20.7889	2.4	21.2427	6.4	56.6472	10.4	92.0517	14.4	127.4562	19	168.1714	
26	2.9376	66	7.4569	106	11.9762	146	16.4955	186	21.0148	2.6	23.0129	6.6	58.4174	10.6	93.8219	14.6	129.2264	19.5	172.5970	
28	3.1635	68	7.6828	108	12.2022	148	16.7215	188	21.2408	2.8	24.7831	6.8	60.1876	10.8	95.5921	14.8	130.9966	20	177.0225	
30	3.3895	70	7.9088	110	12.4281	150	16.9475	190	21.4668	3	26.5534	7	61.9579	11	97.3624	15	132.7669	20.5	181.4480	
32	3.6155	72	8.1348	112	12.6541	152	17.1734	192	21.6927	3.2	28.3236	7.2	63.7281	11.2	99.1326	15.2	134.5371	21	185.8736	
34	3.8414	74	8.3607	114	12.8801	154	17.3994	194	21.9187	3.4	30.0938	7.4	65.4983	11.4	100.9028	15.4	136.3073	22	194.7247	
36	4.0674	76	8.5867	116	13.1060	156	17.6253	196	22.1447	3.6	31.8640	7.6	67.2685	11.6	102.6730	15.6	138.0775	23	203.5759	
38	4.2934	78	8.8127	118	13.3320	158	17.8513	198	22.3706	3.8	33.6342	7.8	69.0388	11.8	104.4433	15.8	139.8478	24	212.4270	
40	4.5193	80	9.0386	120	13.5580	160	18.0773	200	22.5966	4	35.4045	8	70.8090	12	106.2135	16	141.6180	25	221.2781	

ft-lbs to N•m

N•m to ft-lbs

ft-lb	N•m	ft-lb	N•m	ft-lb	N•m	ft-lb	N•m	ft-lb	N•m	N•m	ft-lb	N•m	ft-lb	N•m	ft-lb	N•m	ft-lb	N•m	ft-lb	N•m
1	1.3558	21	28.4722	41	55.5885	61	82.7049	81	109.8212	1	.7376	21	15.9888	41	30.2400	61	44.9913	81	59.7425	
2	2.7116	22	29.8280	42	56.9444	62	84.0607	82	111.1770	2	1.4751	22	16.2264	42	30.9776	62	45.7289	82	60.4801	
3	4.0675	23	31.1838	43	58.3002	63	85.4165	83	112.5328	3	2.2127	23	16.9639	43	31.7152	63	46.4664	83	61.2177	
4	5.4233	24	32.5396	44	59.6560	64	86.7723	84	113.8888	4	2.9502	24	17.7015	44	32.4527	64	47.2040	84	61.9552	
5	6.7791	25	33.8954	45	61.0118	65	88.1281	85	115.2446	5	3.6878	25	18.4391	45	33.1903	65	47.9415	85	62.6928	
6	8.1349	26	35.2513	46	62.3676	66	89.4840	86	116.6004	6	4.4254	26	19.1766	46	33.9279	66	48.6791	86	63.4303	
7	9.4907	27	36.6071	47	63.7234	67	90.8398	87	117.9562	7	5.1629	27	19.9142	47	34.6654	67	49.4167	87	64.1679	
8	10.8465	28	37.9629	48	65.0793	68	92.1956	88	119.3120	8	5.9005	28	20.6517	48	35.4030	68	50.1542	88	64.9545	
9	12.2024	29	39.3187	49	66.4351	69	93.5514	89	120.6678	9	6.6381	29	21.3893	49	36.1405	69	50.8918	89	65.6430	
10	13.5582	30	40.6745	50	67.7909	70	94.9073	90	122.0236	10	7.3756	30	22.1269	50	36.8781	70	51.6293	90	66.3806	
11	14.9140	31	42.0304	51	69.1467	71	96.2631	91	123.3794	11	8.1132	31	22.8644	51	37.6157	71	52.3669	91	67.1181	
12	16.2698	32	43.3862	52	70.5025	72	97.6189	92	124.7352	12	8.8507	32	23.6020	52	38.3532	72	53.1045	92	67.8557	
13	17.6256	33	44.7420	53	71.8583	73	98.9747	93	126.0910	13	9.5883	33	24.3395	53	39.0908	73	53.8420	93	68.5933	
14	18.9815	34	46.0978	54	73.2142	74	100.3316	94	127.4468	14	10.3259	34	25.0771	54	39.8284	74	54.5720	94	69.3308	
15	20.3373	35	47.4536	55	74.5700	75	101.6862	95	128.8026	15	11.0634	35	25.8147	55	40.5659	75	55.3129	95	70.0684	
16	21.6931	36	48.8094	56	75.9258	76	103.0422	96	130.1586	16	11.8010	36	26.5522	56	41.3035	76	56.0547	96	70.8060	
17	23.0489	37	50.1653	57	77.2816	77	104.3980	97	131.5144	17	12.5386	37	27.2898	57	42.0410	77	56.7923	97	71.5435	
18	24.4047	38	51.5211	58	78.6374	78	105.7538	98	132.8702	18	13.2761	38	28.0274	58	42.7786	78	57.5298	98	72.2816	
19	25.7605	39	52.8769	59	79.9933	79	107.1196	99	134.2260	19	14.0137	39	28.7649	59	43.5162	79	58.2674	99	73.0187	
20	27.1164	40	54.2327	60	81.3491	80	108.4654	100	135.5820	20	14.7512	40	29.5025	60	44.2537	80	59.0050	100	73.7562	

in. to mm

mm to in.

in.	mm	in.	mm	in.	mm	in.	mm	mm	in.	mm	in.	mm	in.	mm	in.	mm	in.	mm	in.
.01	.254	.21	5.334	.41	10.414	.61	15.494	.81	20.574	.01	.00039	.21	.00827	.41	.01614	.61	.02402	.81	.03189
.02	.508	.22	5.588	.42	10.668	.62	15.748	.82	20.828	.02	.00079	.22	.00866	.42	.01654	.62	.02441	.82	.03228
.03	.762	.23	5.842	.43	10.922	.63	16.002	.83	21.082	.03	.00118	.23	.00906	.43	.01693	.63	.02480	.83	.03268
.04	1.016	.24	6.096	.44	11.176	.64	16.256	.84	21.336	.04	.00157	.24	.00945	.44	.01732	.64	.02520	.84	.03307
.05	1.270	.25	6.350	.45	11.430	.65	16.510	.85	21.590	.05	.00197	.25	.00984	.45	.01772	.65	.02559	.85	.03346
.06	1.524	.26	6.604	.46	11.684	.66	16.764	.86	21.844	.06	.00236	.26	.01024	.46	.01811	.66	.02598	.86	.03385
.07	1.778	.27	6.858	.47	11.938	.67	17.018	.87	22.098	.07	.00276	.27	.01063	.47	.01850	.67	.02638	.87	.03425
.08	2.032	.28	7.112	.48	12.192	.68	17.272	.88	22.352	.08	.00315	.28	.01102	.48	.01890	.68	.02677	.88	.03465
.09	2.286	.29	7.366	.49	12.446	.69	17.526	.89	22.606	.09	.00354	.29	.01142	.49	.01929	.69	.02717	.89	.03504
.10	2.540	.30	7.620	.50	12.700	.70	17.780	.90	22.860	.10	.00394	.30	.01181	.50	.01969	.70	.02756	.90	.03543
.11	2.794	.31	7.874	.51	12.954	.71	18.034	.91	23.114	.11	.00433	.31	.01220	.51	.02008	.71	.02795	.91	.03583
.12	3.048	.32	8.128	.52	13.208	.72	18.288	.92	23.368	.12	.00472	.32	.01260	.52	.02047	.72	.02835	.92	.03623
.13	3.302	.33	8.382	.53	13.462	.73	18.542	.93	23.622	.13	.00512	.33	.01299	.53	.02087	.73	.02874	.93	.03661
.14	3.556	.34	8.636	.54	13.716	.74	18.796	.94	23.876	.14	.00551	.34	.01339	.54	.02126	.74	.02913	.94	.03701
.15	3.810	.35	8.890	.55	13.970	.75	19.050	.95	24.130	.15	.00591	.35	.01378	.55	.02165	.75	.02953	.95	.03740
.16	4.064	.36	9.144	.56	14.224	.76	19.304	.96	24.384	.16	.00630	.36	.01417	.56	.02205	.76	.02992	.96	.03780
.17	4.318	.37	9.398	.57	14.478	.77	19.558	.97	24.638	.17	.00669	.37	.01457	.57	.02244	.77	.03032	.97	.03819
.18	4.572	.38	9.652	.58	14.732	.78	19.812	.98	24.892	.18	.00709	.38	.01496	.58	.02283	.78	.03071	.98	.03858
.19	4.826	.39	9.906	.59	14.986	.79	20.066	.99	25.146	.19	.00748	.39	.01535	.59	.02323	.79	.03110	.99	.03898
.20	5.080	.40	10.160	.60	15.240	.80													

## TORQUE REFERENCES

tions Chart for torque references not listed in the individual torque charts (Fig. 9).

### DESCRIPTION

Individual Torque Charts appear within many of the Groups. Refer to the Standard Torque Specifica-

#### SPECIFIED TORQUE FOR STANDARD BOLTS

Class	Diameter mm	Pitch mm	Specified torque					
			Hexagon head bolt			Hexagon flange bolt		
			N•m	kgf-cm	ft-lbf	N•m	kgf-cm	ft-lbf
4T	6	1	5	55	48 in.-lbf	6	60	52 in.-lbf
	8	1.25	12.5	130	9	14	145	10
	10	1.25	26	260	19	29	290	21
	12	1.25	47	480	35	53	540	39
	14	1.5	74	760	55	84	850	61
	16	1.5	115	1,150	83	—	—	—
5T	6	1	6.5	65	56 in.-lbf	7.5	75	65 in.-lbf
	8	1.25	15.5	160	12	17.5	175	13
	10	1.25	32	330	24	36	360	26
	12	1.25	59	600	43	65	670	48
	14	1.5	91	930	67	100	1,050	76
	16	1.5	140	1,400	101	—	—	—
6T	6	1	8	80	69 in.-lbf	9	90	78 in.-lbf
	8	1.25	19	195	14	21	210	15
	10	1.25	39	400	29	44	440	32
	12	1.25	71	730	53	80	810	59
	14	1.5	110	1,100	80	125	1,250	90
	16	1.5	170	1,750	127	—	—	—
7T	6	1	10.5	110	8	12	120	9
	8	1.25	25	260	19	28	290	21
	10	1.25	52	530	38	58	590	43
	12	1.25	95	970	70	105	1,050	76
	14	1.5	145	1,500	108	165	1,700	123
	16	1.5	230	2,300	166	—	—	—
8T	8	1.25	29	300	22	33	330	24
	10	1.25	61	620	45	68	690	50
	12	1.25	110	1,100	80	120	1,250	90
9T	8	1.25	34	340	25	37	380	27
	10	1.25	70	710	51	78	790	57
	12	1.25	125	1,300	94	140	1,450	105
10T	8	1.25	38	390	28	42	430	31
	10	1.25	78	800	58	88	890	64
	12	1.25	140	1,450	105	155	1,600	116
11T	8	1.25	42	430	31	47	480	35
	10	1.25	87	890	64	97	990	72
	12	1.25	155	1,600	116	175	1,800	130

Fig. 9 TORQUE SPECIFICATIONS



# LUBRICATION & MAINTENANCE







## TABLE OF CONTENTS

	page		page
<b>INTERNATIONAL SYMBOLS</b>		DESCRIPTION - MANUAL TRANSMISSION . . .	4
DESCRIPTION . . . . .	1	DESCRIPTION - AUTOMATIC	
<b>FLUID TYPES</b>		TRANSMISSION FLUID . . . . .	4
DESCRIPTION		OPERATION - AUTOMATIC TRANSMISSION	
DESCRIPTION - FUEL REQUIREMENTS -		FLUID . . . . .	5
DIESEL ENGINE . . . . .	1	<b>FLUID CAPACITIES</b>	
DESCRIPTION - ENGINE OIL AND		SPECIFICATIONS	
LUBRICANTS . . . . .	2	FLUID CAPACITIES . . . . .	5
DESCRIPTION - POWER STEERING FLUID . .	3	<b>MAINTENANCE SCHEDULES</b>	
DESCRIPTION - ENGINE COOLANT . . . . .	3	DESCRIPTION . . . . .	6
DESCRIPTION - TRANSFER CASE - NV241		<b>JUMP STARTING</b>	
GENII . . . . .	4	STANDARD PROCEDURE - JUMP STARTING . . .	13
DESCRIPTION - TRANSFER CASE - NV271 . .	4	<b>HOISTING</b>	
DESCRIPTION - TRANSFER CASE - NV243 . .	4	STANDARD PROCEDURE - HOISTING . . . . .	14
DESCRIPTION - TRANSFER CASE - NV273 . .	4	<b>TOWING</b>	
DESCRIPTION - AXLE . . . . .	4	STANDARD PROCEDURE - TOWING . . . . .	15

## INTERNATIONAL SYMBOLS

### DESCRIPTION

DaimlerChrysler Corporation uses international symbols to identify engine compartment lubricant and fluid inspection and fill locations (Fig. 1).

	ENGINE OIL		BRAKE FLUID
	AUTOMATIC TRANSMISSION FLUID		POWER STEERING FLUID
	ENGINE COOLANT		WINDSHIELD WASHER FLUID

8097ddb

Fig. 1 INTERNATIONAL SYMBOLS

## FLUID TYPES

### DESCRIPTION

#### DESCRIPTION - FUEL REQUIREMENTS - DIESEL ENGINE

### DESCRIPTION

**WARNING:** Do not use alcohol or gasoline as a fuel blending agent. They can be unstable under certain conditions and hazardous or explosive when mixed with diesel fuel.

Use good quality diesel fuel from a reputable supplier in your Dodge truck. For most year-round service, number 2 diesel fuel meeting ASTM specification D-975 will provide good performance. If the vehicle is exposed to extreme cold (below 0°F/-18°C), or is required to operate at colder-than-normal conditions for prolonged periods, use climatized No. 2 diesel fuel or dilute the No. 2 diesel fuel with 50% No. 1 diesel fuel. This will provide better protection from fuel gelling or wax-plugging of the fuel filters.

## FLUID TYPES (Continued)

Diesel fuel is seldom completely free of water. To prevent fuel system trouble, including fuel line freezing in winter, drain the accumulated water from the fuel/water separator using the fuel/water separator drain provided. If you buy good-quality fuel and follow the cold-weather advice above, fuel conditioners should not be required in your vehicle. If available in your area, a high cetane "premium" diesel fuel may offer improved cold starting and warm-up performance.

## DESCRIPTION - ENGINE OIL AND LUBRICANTS

**WARNING: NEW OR USED ENGINE OIL CAN BE IRRITATING TO THE SKIN. AVOID PROLONGED OR REPEATED SKIN CONTACT WITH ENGINE OIL. CONTAMINANTS IN USED ENGINE OIL, CAUSED BY INTERNAL COMBUSTION, CAN BE HAZARDOUS TO YOUR HEALTH. THOROUGHLY WASH EXPOSED SKIN WITH SOAP AND WATER. DO NOT WASH SKIN WITH GASOLINE, DIESEL FUEL, THINNER, OR SOLVENTS, HEALTH PROBLEMS CAN RESULT. DO NOT POLLUTE, DISPOSE OF USED ENGINE OIL PROPERLY. CONTACT YOUR DEALER OR GOVERNMENT AGENCY FOR LOCATION OF COLLECTION CENTER IN YOUR AREA.**

When service is required, DaimlerChrysler Corporation recommends that only Mopar® brand parts, lubricants and chemicals be used. Mopar® provides the best engineered products for servicing DaimlerChrysler Corporation vehicles.

Only lubricants bearing designations defined by the following organization should be used.

- Society of Automotive Engineers (SAE)
- American Petroleum Institute (API)
- National Lubricating Grease Institute (NLGI)

## API SERVICE GRADE CERTIFIED

Use an engine oil that is API Certified. MOPAR® provides engine oils, that meet or exceed this requirement.

## SAE VISCOSITY

An SAE viscosity grade is used to specify the viscosity of engine oil. Use only engine oils with multiple viscosities such as 5W-30 or 10W-30. These are specified with a dual SAE viscosity grade which indicates the cold-to-hot temperature viscosity range. Select an engine oil that is best suited to your particular temperature range and variation (Fig. 2).

## ENERGY CONSERVING OIL

An Energy Conserving type oil is recommended for gasoline engines. The designation of ENERGY CONSERVING is located on the label of an engine oil container.

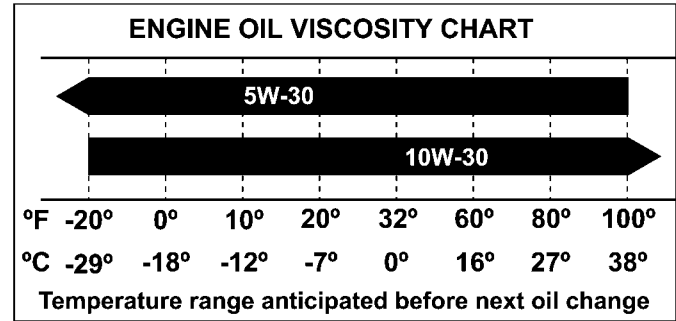

80990199

*Fig. 2 TEMPERATURE/ENGINE OIL VISCOSITY*

## CONTAINER IDENTIFICATION

Standard engine oil identification notations have been adopted to aid in the proper selection of engine oil. The identifying notations are located on the front label of engine oil plastic bottles and the top of engine oil cans (Fig. 3).

This symbol means that the oil has been certified by the American Petroleum Institute (API). DaimlerChrysler only recommend API Certified engine oils. Use Mopar® engine oil or equivalent.



9400-9

*Fig. 3 API SYMBOL*

## GEAR LUBRICANTS

SAE ratings also apply to multigrade gear lubricants. In addition, API classification defines the lubricants usage. Such as API GL-5 and SAE 75W-90.

## LUBRICANTS AND GREASES

Lubricating grease is rated for quality and usage by the NLGI. All approved products have the NLGI symbol (Fig. 4) on the label. At the bottom of the NLGI symbol is the usage and quality identification letters. Wheel bearing lubricant is identified by the letter "G". Chassis lubricant is identified by the letter "L". The letter following the usage letter indicates the quality of the lubricant. The following symbols indicate the highest quality.

FLUID TYPES (Continued)

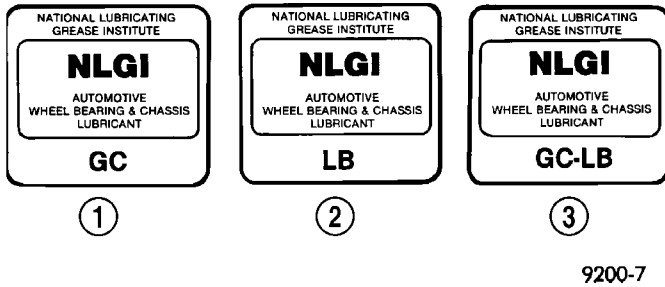

Fig. 4 NLGI SYMBOL

- 1 - WHEEL BEARINGS
- 2 - CHASSIS LUBRICATION
- 3 - CHASSIS AND WHEEL BEARINGS

SPECIALIZED LUBRICANTS AND OILS

Some maintenance or repair procedures may require the use of specialized lubricants or oils. Consult the appropriate sections in this manual for the correct application of these lubricants.

DESCRIPTION - POWER STEERING FLUID

Mopar® ATF +4, Automatic Transmission Fluid is required in the power steering system. Substitute fluids can induce power steering system failure.

Mopar® ATF +4, Automatic Transmission Fluid when new is red in color. The ATF is dyed red so it can be identified from other fluids used in the vehicle such as engine oil or antifreeze. The red color is not permanent and is not an indicator of fluid condition. As the vehicle is driven, the ATF will begin to look darker in color and may eventually become brown. **This is normal.** ATF+4 also has a unique odor that may change with age. Consequently, odor and color cannot be used to indicate the fluid condition or the need for a fluid change.

DESCRIPTION - ENGINE COOLANT

**WARNING: ANTIFREEZE IS AN ETHYLENE GLYCOL BASE COOLANT AND IS HARMFUL IF SWALLOWED OR INHALED. IF SWALLOWED, DRINK TWO GLASSES OF WATER AND INDUCE VOMITING. IF INHALED, MOVE TO FRESH AIR AREA. SEEK MEDICAL ATTENTION IMMEDIATELY. DO NOT STORE IN OPEN OR UNMARKED CONTAINERS. WASH SKIN AND CLOTHING THOROUGHLY AFTER COMING IN CONTACT WITH ETHYLENE GLYCOL. KEEP OUT OF REACH OF CHILDREN. DISPOSE OF GLYCOL BASE COOLANT PROPERLY, CONTACT YOUR DEALER OR GOVERNMENT AGENCY FOR LOCATION OF COLLECTION CENTER IN YOUR AREA. DO NOT OPEN A COOLING SYSTEM WHEN THE ENGINE IS AT OPERATING TEMPERATURE OR HOT UNDER PRESSURE, PERSONAL INJURY CAN RESULT. AVOID RADIATOR COOLING FAN WHEN**

**ENGINE COMPARTMENT RELATED SERVICE IS PERFORMED, PERSONAL INJURY CAN RESULT.**

**CAUTION: Use of Propylene Glycol based coolants is not recommended, as they provide less freeze protection and less corrosion protection.**

The cooling system is designed around the coolant. The coolant must accept heat from engine metal, in the cylinder head area near the exhaust valves and engine block. Then coolant carries the heat to the radiator where the tube/fin radiator can transfer the heat to the air.

The use of aluminum cylinder blocks, cylinder heads, and water pumps requires special corrosion protection. Mopar® Antifreeze/Coolant, 5 Year/100,000 Mile Formula (MS-9769), or the equivalent ethylene glycol base coolant with organic corrosion inhibitors (called HOAT, for Hybrid Organic Additive Technology) is recommended. This coolant offers the best engine cooling without corrosion when mixed with 50% Ethylene Glycol and 50% distilled water to obtain a freeze point of -37°C (-35°F). If it loses color or becomes contaminated, drain, flush, and replace with fresh properly mixed coolant solution.

**CAUTION: Mopar® Antifreeze/Coolant, 5 Year/100,000 Mile Formula (MS-9769) may not be mixed with any other type of antifreeze. Mixing of coolants other than specified (non-HOAT or other HOAT), may result in engine damage that may not be covered under the new vehicle warranty, and decreased corrosion protection.**

COOLANT PERFORMANCE

The required ethylene-glycol (antifreeze) and water mixture depends upon climate and vehicle operating conditions. The coolant performance of various mixtures follows:

**Pure Water**-Water can absorb more heat than a mixture of water and ethylene-glycol. This is for purpose of heat transfer only. Water also freezes at a higher temperature and allows corrosion.

**100 percent Ethylene-Glycol**-The corrosion inhibiting additives in ethylene-glycol need the presence of water to dissolve. Without water, additives form deposits in system. These act as insulation causing temperature to rise to as high as 149°C (300°F). This temperature is hot enough to melt plastic and soften solder. The increased temperature can result in engine detonation. In addition, 100 percent ethylene-glycol freezes at -22°C (-8°F).

**50/50 Ethylene-Glycol and Water**-Is the recommended mixture, it provides protection against freezing to -37°C (-34°F). The antifreeze concentration



## FLUID TYPES (Continued)

**must always** be a minimum of 44 percent, year-round in all climates. If percentage is lower, engine parts may be eroded by cavitation. Maximum protection against freezing is provided with a 68 percent antifreeze concentration, which prevents freezing down to -67.7°C (-90°F). A higher percentage will freeze at a warmer temperature. Also, a higher percentage of antifreeze can cause the engine to over-heat because specific heat of antifreeze is lower than that of water.

**CAUTION:** Richer antifreeze mixtures cannot be measured with normal field equipment and can cause problems associated with 100 percent ethylene-glycol.

## COOLANT SELECTION AND ADDITIVES

**NOTE:** Refer to the vehicle's coolant bottle to identify HOAT or Non-HOAT coolant. Non-HOAT coolant is green in color.

The use of aluminum cylinder blocks, cylinder heads and water pumps requires special corrosion protection. Only Mopar® Antifreeze/Coolant, 5 Year/100,000 Mile Formula (glycol base coolant with corrosion inhibitors called HOAT, for Hybrid Organic Additive Technology) is recommended. This coolant offers the best engine cooling without corrosion when mixed with 50% distilled water to obtain a freeze point of -37°C (-35°F). If it loses color or becomes contaminated, drain, flush, and replace with fresh properly mixed coolant solution.

**CAUTION:** Do not use coolant additives that are claimed to improve engine cooling.

## DESCRIPTION - TRANSFER CASE - NV241 GENII

Recommended lubricant for the NV241 GENII transfer case is Mopar® ATF +4, Automatic Transmission Fluid.

## DESCRIPTION - TRANSFER CASE - NV271

Recommended lubricant for the NV271 transfer case is Mopar® ATF +4, Automatic Transmission Fluid.

## DESCRIPTION - TRANSFER CASE - NV243

Recommended lubricant for the NV243 transfer case is Mopar® ATF +4, Automatic Transmission Fluid.

## DESCRIPTION - TRANSFER CASE - NV273

Recommended lubricant for the NV273 transfer case is Mopar® ATF +4, Automatic Transmission Fluid.

## DESCRIPTION - AXLE

**NOTE:** DaimlerChrysler recommends using Mopar® lubricants or lubricants of equal quality.

## FRONT AXLE

- C205F - Mopar® Gear Lubricant 75W-90
- 9 1/4 AA - Mopar® Synthetic Gear Lubricant 75W-90

## REAR AXLE

- 9 1/4 - Mopar® Synthetic Gear Lubricant 75W-140
- 10 1/2 AA - Mopar® Synthetic Gear Lubricant 75W-90
- 11 1/2 AA - Mopar® Synthetic Gear Lubricant 75W-90

**NOTE:** Trac-Lok® differentials require Limited Slip Additive in the lubricant. Trac-Rite™ differentials DO NOT require Limited Slip Additive.

## DESCRIPTION - MANUAL TRANSMISSION

**NOTE:** DaimlerChrysler recommends using Mopar® lubricants or lubricants of equal quality.

- NV3500 - Mopar® Manual Transmission Lubricant
- NV4500 - Mopar® Synthetic 75W85 Manual Transmission Lubricant
- NV5600 - Mopar® Manual Transmission Lubricant

## DESCRIPTION - AUTOMATIC TRANSMISSION FLUID

**NOTE:** Refer to Service Procedures in this group for fluid level checking procedures.

Mopar® ATF +4, Automatic Transmission Fluid is the recommended fluid for DaimlerChrysler automatic transmissions.

**Dexron II fluid IS NOT recommended. Clutch chatter can result from the use of improper fluid.**

Mopar® ATF +4, Automatic Transmission Fluid when new is red in color. The ATF is dyed red so it can be identified from other fluids used in the vehicle such as engine oil or antifreeze. The red color is not permanent and is not an indicator of fluid condition. As the vehicle is driven, the ATF will begin to look darker in color and may eventually become brown. **This is normal.** ATF+4 also has a unique odor that may change with age. Consequently, odor and color cannot be used to indicate the fluid condition or the need for a fluid change.

FLUID TYPES (Continued)

**FLUID ADDITIVES**

DaimlerChrysler strongly recommends against the addition of any fluids to the transmission, other than those automatic transmission fluids listed above. Exceptions to this policy are the use of special dyes to aid in detecting fluid leaks.

Various "special" additives and supplements exist that claim to improve shift feel and/or quality. These additives and others also claim to improve converter clutch operation and inhibit overheating, oxidation, varnish, and sludge. These claims have not been supported to the satisfaction of DaimlerChrysler and these additives **must not be used**. The use of transmission "sealers" should also be avoided, since they may adversely affect the integrity of transmission seals.

**OPERATION - AUTOMATIC TRANSMISSION FLUID**

The automatic transmission fluid is selected based upon several qualities. The fluid must provide a high level of protection for the internal components by providing a lubricating film between adjacent metal components. The fluid must also be thermally stable so that it can maintain a consistent viscosity through a large temperature range. If the viscosity stays constant through the temperature range of operation, transmission operation and shift feel will remain consistent. Transmission fluid must also be a good conductor of heat. The fluid must absorb heat from the internal transmission components and transfer that heat to the transmission case.

**FLUID CAPACITIES**

**SPECIFICATIONS**

**FLUID CAPACITIES**

2DESCRIPTION	SPECIFICATION
<b>FUEL TANK</b>	
Short Box (Lt. Duty)	98 L (26 gal.)*
Long Box (Lt. Duty)	132 L (35 gal.)*
<b>ENGINE OIL WITH FILTER</b>	
3.7L	4.7 L (5.0 qts.)
4.7L	5.6 L (6.0 qts.)
5.7L	6.6 L (7.0 qts.)
5.9L	4.7 L (5.0 qts.)
8.0L	6.6 L (7.0 qts.)
5.9L DIESEL	10.4 L (11.0 qts.)

2DESCRIPTION	SPECIFICATION
<b>COOLING SYSTEM</b>	
3.7L	15.4 L (16.2 qts.)**
4.7L	15.4 L (16.2 qts.)**
5.7L	15.4L (16.2 qts.)**
5.9L	15.5 L (16.3 qts.)**
8.0L	24L (24.3 qts.)**
5.9L Diesel Engine	28L (29.5 qts.)**
<b>POWER STEERING</b>	
Power steering fluid capacities are dependent on engine/chassis options as well as steering gear/cooler options. Depending on type and size of internal cooler, length and inside diameter of cooler lines, or use of an auxiliary cooler, these capacities may vary. Refer to 19, Steering for proper fill and bleed procedures.	
<b>AUTOMATIC TRANSMISSION</b>	
Service Fill - 46RE	3.8 L (4.0 qts.)
O-haul - 46RE	9-9.5L (19-20 pts.) ◇
Service Fill - 45RFE/ 545RFE	4X2 - 5.2 L (11.0 pts.) 4X4 - 6.2 L (13.0 pts.)
O-haul - 45RFE/545RFE	14-16 L (29-33 pts.) ◇
◇ Dry fill capacity Depending on type and size of internal cooler, length and inside diameter of cooler lines, or use of an auxiliary cooler, these figures may vary. (Refer to 21 - TRANSMISSION/TRANSAXLE/AUTOMATIC/FLUID - STANDARD PROCEDURE)	
<b>MANUAL TRANSMISSION</b>	
NV3500 4X2	2.3 L (4.8 pts.)
NV3500 4X4	2.0 L (4.2 pts.)
NV4500	3.8 L (8.0 pts.)
NV5600	4.5 L (9.5 pts.)
<b>TRANSFER CASE</b>	
NV241 GENII	1.6 L (3.4 pts.)
NV243	1.6 L (3.4 pts.)
NV271	1.89 L (4.0 pts.)
NV273	1.89 L (4.0 pts.)
<b>FRONT AXLE ± .03 L (1 oz)</b>	
C205F	1.66 L (3.5 pts.)
9 1/4 AA	2.25 L (4.75 pts.)
<b>REAR AXLE ± .03 L (1 oz)</b>	
9 1/4	2.32 L (4.9 pts.)***
10 1/2 AA	2.25 L (4.75 pts.)
11 1/2 AA	3.62 L (7.65 pts)
*** With Trac-Lok add 118 ml (4 oz.) of Limited Slip Additive.	
** Includes 0.9L (1.0 qts.) for coolant reservoir.	
*Nominal refill capacities are shown. A variation may be observed from vehicle to vehicle due to manufacturing tolerance and refill procedure.	

## MAINTENANCE SCHEDULES

### DESCRIPTION

Maintenance Schedule Information not included in this section, is located in the appropriate Owner's Manual.

There are two maintenance schedules that show the **required** service for your vehicle.

First is Schedule "B". It is for vehicles that are operated under the conditions that are listed below and at the beginning of the schedule.

- Day or night temperatures are below 0° C (32° F).
- Stop and go driving.
- Extensive engine idling.
- Driving in dusty conditions.
- Short trips of less than 16 km (10 miles).
- More than 50% of your driving is at sustained high speeds during hot weather, above 32° C (90° F).
- Trailer towing.
- Taxi, police, or delivery service (commercial service).
- Off-road or desert operation.
- **If equipped for and operating with E-85 (ethanol) fuel.**

**NOTE: Most vehicles are operated under the conditions listed for Schedule "B".**

Second is Schedule "A". It is for vehicles that are not operated under any of the conditions listed under Schedule "B".

Use the schedule that best describes your driving conditions. Where time and mileage are listed, follow the interval that occurs first.

**CAUTION: Failure to perform the required maintenance items may result in damage to the vehicle.**

#### **At Each Stop for Fuel**

- Check the engine oil level about 5 minutes after a fully warmed engine is shut off. Checking the oil level while the vehicle is on level ground will improve the accuracy of the oil level reading. Add oil only when the level is at or below the ADD or MIN mark.
- Check the windshield washer solvent and add if required.

#### **Once a Month**

- Check tire pressure and look for unusual wear or damage.
- Inspect the battery and clean and tighten the terminals as required.
- Check the fluid levels of coolant reservoir, brake master cylinder, power steering and transmission and add as needed.
- Check all lights and all other electrical items for correct operation.

#### **At Each Oil Change**

- Change the engine oil filter.
- Inspect the exhaust system.
- Inspect the brake hoses.
- Inspect the CV joints (if equipped) and front suspension components.
- Check the automatic transmission fluid level.
- Check the manual transmission fluid level.
- Check the coolant level, hoses, and clamps.
- Rotate the tires at each oil change interval shown on Schedule "A" 10 000 km (6,000 miles) or every other interval shown on Schedule "B" 10 000 km (6,000 miles).

#### **Schedule "B"**

Follow schedule "B" if you usually operate your vehicle under one or more of the following conditions.

- Day or night temperatures are below 0° C (32° F).
- Stop and go driving.
- Extensive engine idling.
- Driving in dusty conditions.
- Short trips of less than 16 km (10 miles).
- More than 50% of your driving is at sustained high speeds during hot weather, above 32° C (90° F).
- Trailer towing.
- Taxi, police, or delivery service (commercial service).
- Off-road or desert operation.
- **If equipped for and operating with E-85 (ethanol) fuel.**

MAINTENANCE SCHEDULES (Continued)

Miles (Kilometers)	3,000 (5 000)	6,000 (10 000)	9,000 (14 000)	12,000 (19 000)	15,000 (24 000)
Change engine oil and engine oil filter.	X	X	X	X	X
Lubricate outer tie rod ends 2500/3500 (4X4) models only.		X		X	
Change rear axle fluid.					X
Change front axle fluid (4X4).					X
Inspect brake linings.				X	
<b>Inspect engine air cleaner filter, replace if necessary.</b>					X

Miles (Kilometers)	18,000 (29 000)	21,000 (34 000)	24,000 (38 000)	27,000 (43 000)	30,000 (48 000)
Change engine oil and engine oil filter.	X	X	X	X	X
Lubricate outer tie rod ends 2500/3500 (4X4) models only.	X		X		X
Change rear axle fluid.					X
Change front axle fluid (4X4).					X
Inspect brake linings.			X		
<b>Inspect engine air cleaner filter, replace if necessary.</b>					X
<b>Replace spark plugs.</b>					X
<b>Inspect PCV valve, replace as necessary.</b>					X*
Drain and refill automatic transmission fluid, change filter and adjust bands (46RE/47RE/48RE).‡					X
Drain and refill automatic transmission fluid and change main sump filter (45RFE/545RFE only).‡					X

Miles (Kilometers)	33,000 (53 000)	36,000 (58 000)	39,000 (62 000)	42,000 (67 000)	45,000 (72 000)
Change engine oil and engine oil filter.	X	X	X	X	X
Lubricate outer tie rod ends 2500/3500 (4X4) models only.		X		X	
Change rear axle fluid.					X
Change front axle fluid (4X4).					X
Inspect brake linings.		X			
<b>Inspect engine air cleaner filter, replace if necessary.</b>					X