

### VIN PLATE DECODING INFORMATION

1	2	3	4	5	6	7	8	9	10	11	12 thru 17
Country	Make	Vehicle Type	Other	Line	Series	Body Style	Engine	Check Digit	Model Year	Assy. Plant	Sequence No.

The following table interprets the VIN Plate position shown above.

Position	Interpretation	Codes = Description
1	Country of Origin	1 = U.S.
2	Assembler	B = Dodge
3	Vehicle Type	7 = Truck
4	GVWR & Pass. Safety	D = 0-3000 lbs (0-1360 kg) E = 3001-4000 lbs (1361-1814 kg) F = 4001-5000 lbs (1815-2267 kg) G = 5001-6000 lbs (2268-2721 kg) H = 6001-7000 lbs (2722-3175 kg) J = 7001-8000 lbs (3176-3628 kg) K = 8001-9000 lbs (3629-4082 kg) L = 9001-10000 lbs (4083-4535 kg) M = 10001-14000 lbs (4536-6350 kg) W = Buses & Incomplete Vehicles With Hydraulic Brakes
5	Vehicle Line	G = Dakota, Dakota/Sport, Dakota 4x4 L = Dakota, Dakota/Sport, Dakota 4x2
6	Series	2 = Dakota/Sport/SLT
7	Body Style	3 = Club Cab (4WD) 6 = Regular Cab (2WD)
8	Engine	P = 2.5L 4 Cyl. (EPE) X = 3.9L 6 Cyl. (EHC) Y = 5.2L 8 Cyl. (ELF) Z = 5.9L 8 Cyl. (EML)
9	Check Digit	0 = Check Digit 0 = Check Digit 0 = Check Digit
10	Model Year	W = 1998 V = 1997
11	Assembly Plant	S = Dodge City
12 thru 17	Vehicle Build Sequence	Model Year Assembly Sequence

# Group - 2

## Front Suspension & Drive

### Group - 2 Front Suspension & Drive

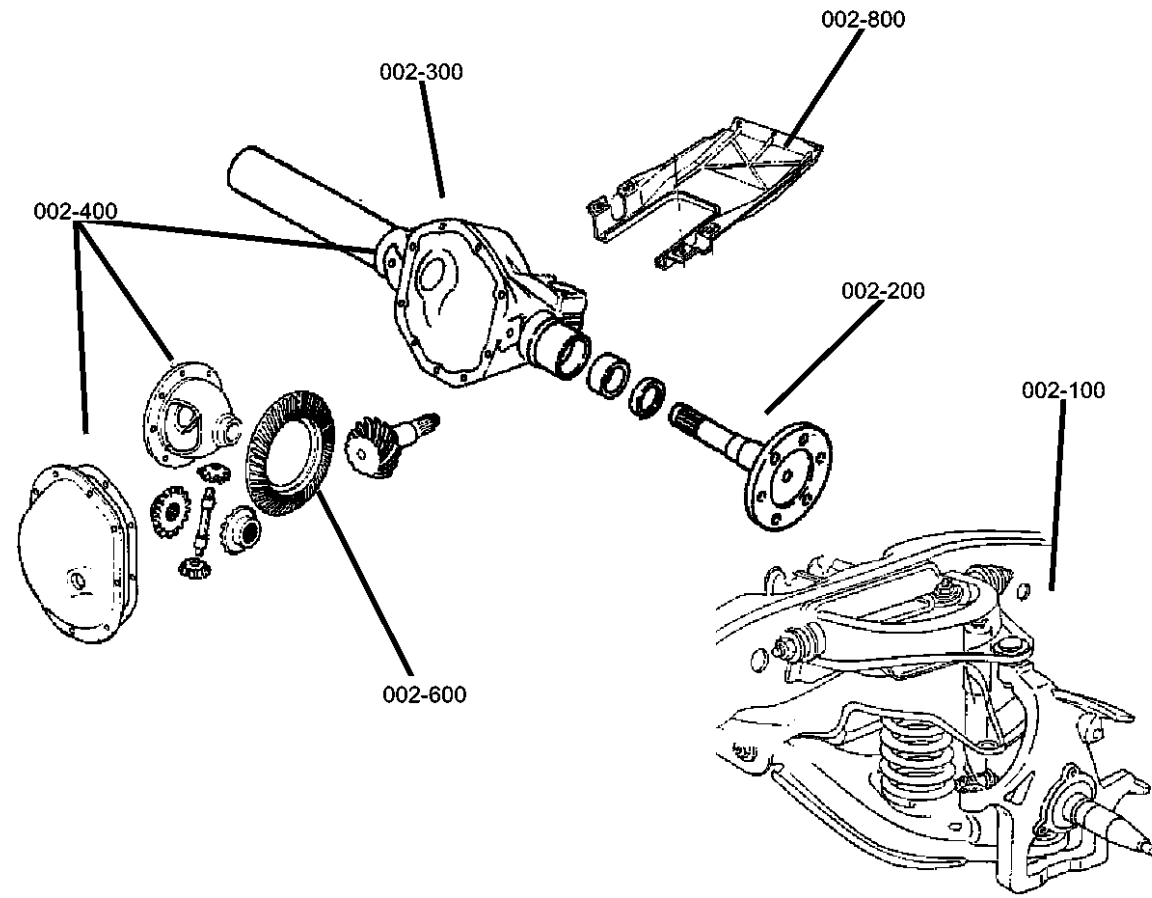

Illustration Title

Group-Fig. No.

#### Front Suspension

Suspension,Front,Control Arms,Springs,Shocks,Knuckles-AN 1 .....	Fig. 2 - 110
Stabilizer Bar,Front-AN 1 .....	Fig. 2 - 120
Suspension,Front,Control Arms,Shocks,Knuckles-AN 5 .....	Fig. 2 - 130
Stabilizer Bar and Torsion Bar,Front-AN 5 .....	Fig. 2 - 140

#### Front Axle Drive Shafts

Shaft,Front Axle Drive .....	Fig. 2 - 210
------------------------------	--------------

#### Front Axle Housing

Housing,Front Axle.....	Fig. 2 - 310
-------------------------	--------------

#### Front Axle Assembly

Axle Assembly,Front .....	Fig. 2 - 410
---------------------------	--------------

#### Front Axle Differential

Differential,Front Axle.....	Fig. 2 - 610
------------------------------	--------------

#### Front Axle Skid Plate

Skid Plate,Front Axle.....	Fig. 2 - 810
----------------------------	--------------

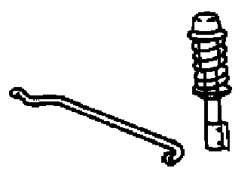
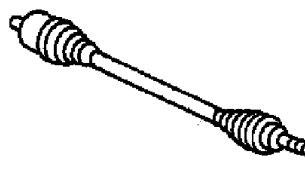
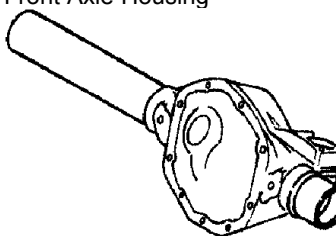
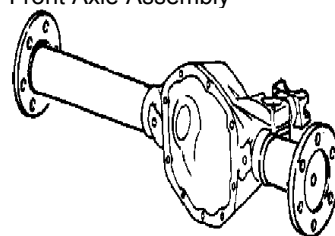
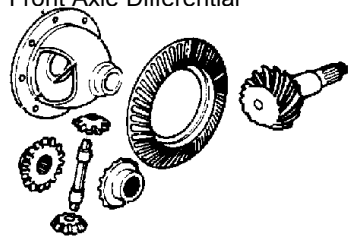
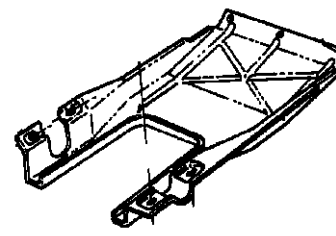
<p><b>002-100</b> Front Suspension</p> 	<p><b>002-200</b> Front Axle Drive Shafts</p> 	<p><b>002-300</b> Front Axle Housing</p> 	<p><b>002-400</b> Front Axle Assembly</p> 
<p><b>002-600</b> Front Axle Differential</p> 	<p><b>002-800</b> Front Axle Skid Plate</p> 		

**Suspension,Front,Control Arms,Springs,Shocks,Knuckles-AN 1**  
**Figure 2-110**

ITEM	PART NUMBER	QTY	LINE	SERIES	BODY	ENGINE	TRANS	TRIM	DESCRIPTION
------	-------------	-----	------	--------	------	--------	-------	------	-------------

Note:Sales Codes defined below;  
 Check the VIN number for proper sales code on Front Springs and Shocks  
 EH0=Engines - All 3.9L V6 Gas  
 EL0=Engines - All 5.2L 8 Cylinder Gas  
 EM0=Engines - All 5.9L 8 Cylinder Gas  
 EP0=Engines - All 2.5L 4 Cylinder Gas  
 LCA=Lower Control Arm  
 SFB= Shock Absorbers - Front Heavy Duty  
 UCA=Upper Control Arm

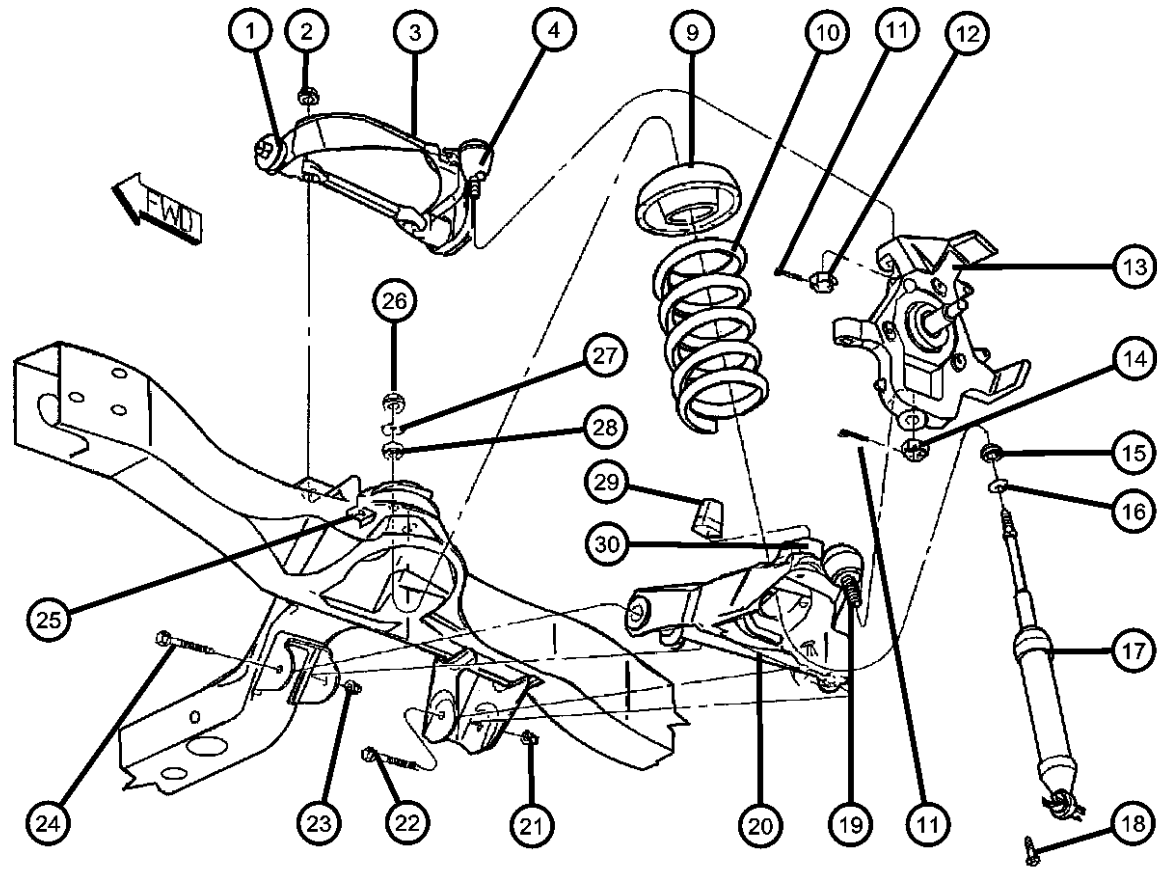

1	52037673	4	1						BUSHING, Control ArmUpper
2	06036048AA	4	1						NUT, Hex Lock, .562 - 18, Pivot Bar Mounting Bolt, Upper Control Arm
3	52039090	2	1						ARM, Control, Complete Assembly, Upper, Right or Left
4	05104788AA	1	1						BALL JOINT PACKAGE, Upper Control ArmRight or Left
-5	06503320	4	1						NUT, Hex Lock, M15x2, Pivot, Upper Control Arm
-6	52038241	4	1						WASHER, Control Arm Shaft, Outer, Upper Front
-7	52038745	2	1						BUMPER, Suspension JounceUpper Control Arm
-8	06504317	2	1						NUT, Hex, Jounce Bumper Mounting, Upper Control Arm
9	52037718	2	1						ISOLATOR, SpringUpper
10									SPRING, Front Coil
	52039198	1	1						[ZBG,ZPG]
	52039199	1	1						[ZBH,ZPH]
	52039200	1	1						[ZBJ,ZPJ]
	52039201	1	1						[ZBK,ZPK]
	52039242	1	1						[ZAC,ZNC]
	52039243	1	1						[ZAD,ZND]
	52039244	1	1						[ZAE,ZNE]
	52039245	1	1						[ZAF,ZNF]
	52039246	1	1						[ZAG,ZNG]

**DAKOTA (AN)**

SERIES      LINE  
 L = Regular Cab    1 = Lt. Duty DODGE 2WD  
 L = Club Cab        5 = Lt. Duty DODGE 4WD

BODY  
 31 = CLUB CAB 2-DR 6.5 FT BOX  
 61 = REG CAB 6.5 FT BOX  
 62 = REG CAB 8 FT BOX

ENGINE  
 EHC = "Magnum" 3.9L SMPI V6 Engine  
 ELF = 5.2L V8 MPI Engine  
 EML = 5.9L V8 MPI Engine  
 EPE = Engine - 2.5L Power Tech I-4 Cyl.

TRANSMISSION  
 DDC = 5-Speed HD Manual Transmission  
 DDK = 5-Speed HD Manual Transmission  
 DDQ = 5-Speed Manual Transmission  
 DGK = 4-Spd. Automatic 42RE Transmission  
 DGT = 4-Spd. Automatic 46RE Transmission  
 DGW = TRANSMISSION - 4-SPD. AUTOMATIC,44RE  
 DD0 = ALL 5 SPEED MANUAL TRANSMISSIONS  
 DG0 = TRANSMISSIONS - ALL AUTOMATIC

AR = use ase required    - = Non illustrated part

1998 AN

Suspension,Front,Control Arms,Springs,Shocks,Knuckles-AN 1

Figure 2-110

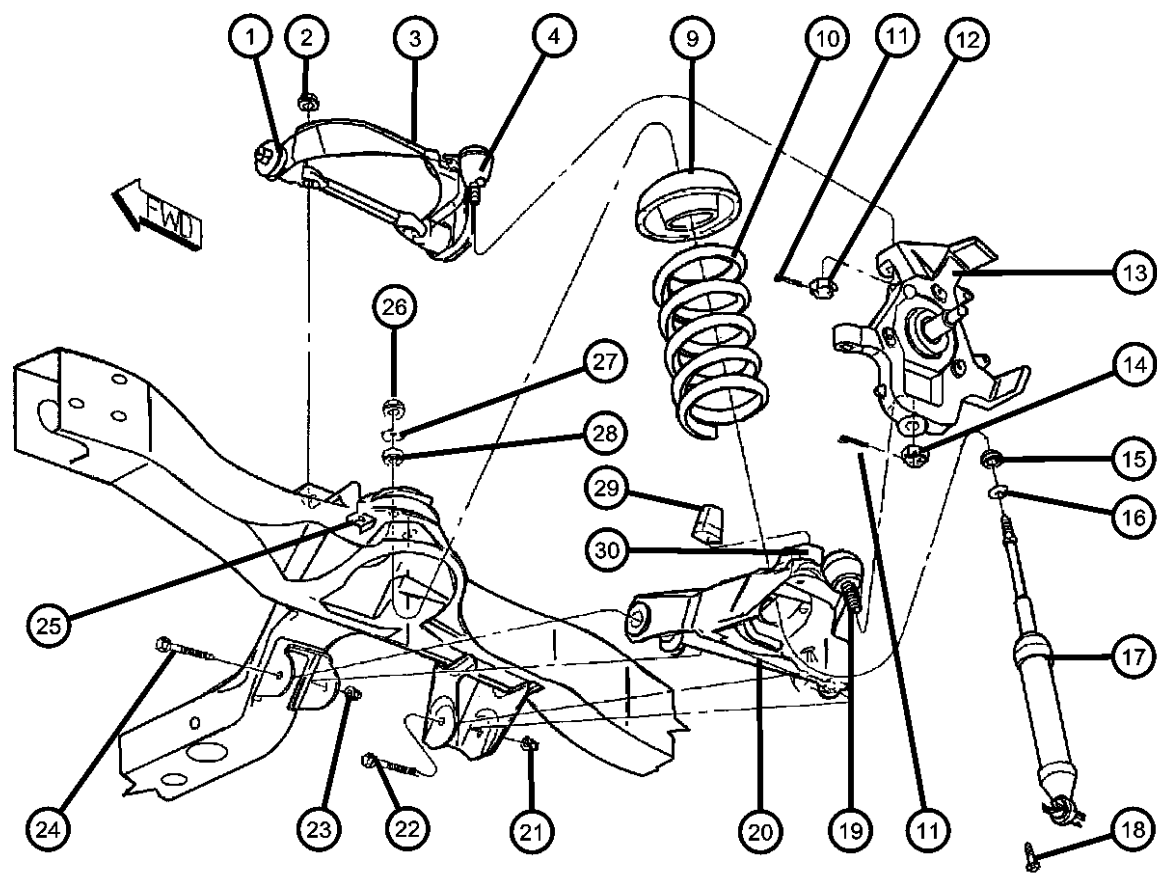

ITEM	PART NUMBER	QTY	LINE	SERIES	BODY	ENGINE	TRANS	TRIM	DESCRIPTION
	52039247	1	1						[ZAH,ZNH]
	52039248	1	1						[ZAJ,ZNJ]
	52039249	1	1						[ZAK,ZNK]
	52106196AA	1	1						[ZBE,ZPE]
	52106197AA	1	1						[ZBF,ZPF]
	52106202	1	1						[ZBL,ZPL]
	52106436AA	1	1		31, 61				[ZCA,ZRA]
11	00120123	2							PIN, Cotter, UCA and LCA Ball Joint Stud
12	06502749	2							NUT, Castle, M14x1.5, Ball Joint Mounting, Upper Control Arm KNUCKLE, Front
13									Right
	52038658	1	1						Left
	52038659	1	1						
14	06502858	2	1						NUT, Hex, Ball Joint Mounting, Lower Control Arm
15	52039478AA	4							GROMMET, Shock AbsorberLower
16	52038809	2							RETAINER, Shock AbsorberLower
17									SHOCK ABSORBER PACKAGE, Suspension, Front
	04883055	2	1			EH0			[SFB,Z1A,Z1B]
	0SGR5609								Rancho Shock
	0SG23318								Mopar V-Line Alternative Part
	04883056	2	1			ELO			[SFB,Z1A,Z1B]
	0SGR5609								Rancho Shock
	0SG23318								Mopar V-Line Alternative Part
	04883057	2	1			EH0, EP0			[SFB,Z1C,Z1D,Z1E]
	04883058	2	1			ELO			[SFB,Z1C,Z1D,Z1E]
	05011245AB	2	1			EP0			[SFB]
	0SG23318								Mopar V-Line Alternative Part

DAKOTA (AN)

SERIES LINE  
 L = Regular Cab 1 = Lt. Duty DODGE 2WD  
 L = Club Cab 5 = Lt. Duty DODGE 4WD

BODY  
 31 = CLUB CAB 2-DR 6.5 FT BOX  
 61 = REG CAB 6.5 FT BOX  
 62 = REG CAB 8 FT BOX

ENGINE  
 EHC = "Magnum" 3.9L SMPI V6 Engine  
 ELF = 5.2L V8 MPI Engine  
 EML = 5.9L V8 MPI Engine  
 EPE = Engine - 2.5L Power Tech I-4 Cyl.

TRANSMISSION  
 DDC = 5-Speed HD Manual Transmission  
 DDK = 5-Speed HD Manual Transmission  
 DDQ = 5-Speed Manual Transmission  
 DGK = 4-Spd. Automatic 42RE Transmission  
 DGT = 4-Spd. Automatic 46RE Transmission  
 DGW = TRANSMISSION - 4-SPD. AUTOMATIC,44RE  
 DD0 = ALL 5 SPEED MANUAL TRANSMISSIONS  
 DG0 = TRANSMISSIONS - ALL AUTOMATIC

AR = use ase required - = Non illustrated part

1998 AN

Suspension,Front,Control Arms,Springs,Shocks,Knuckles-AN 1

Figure 2-110

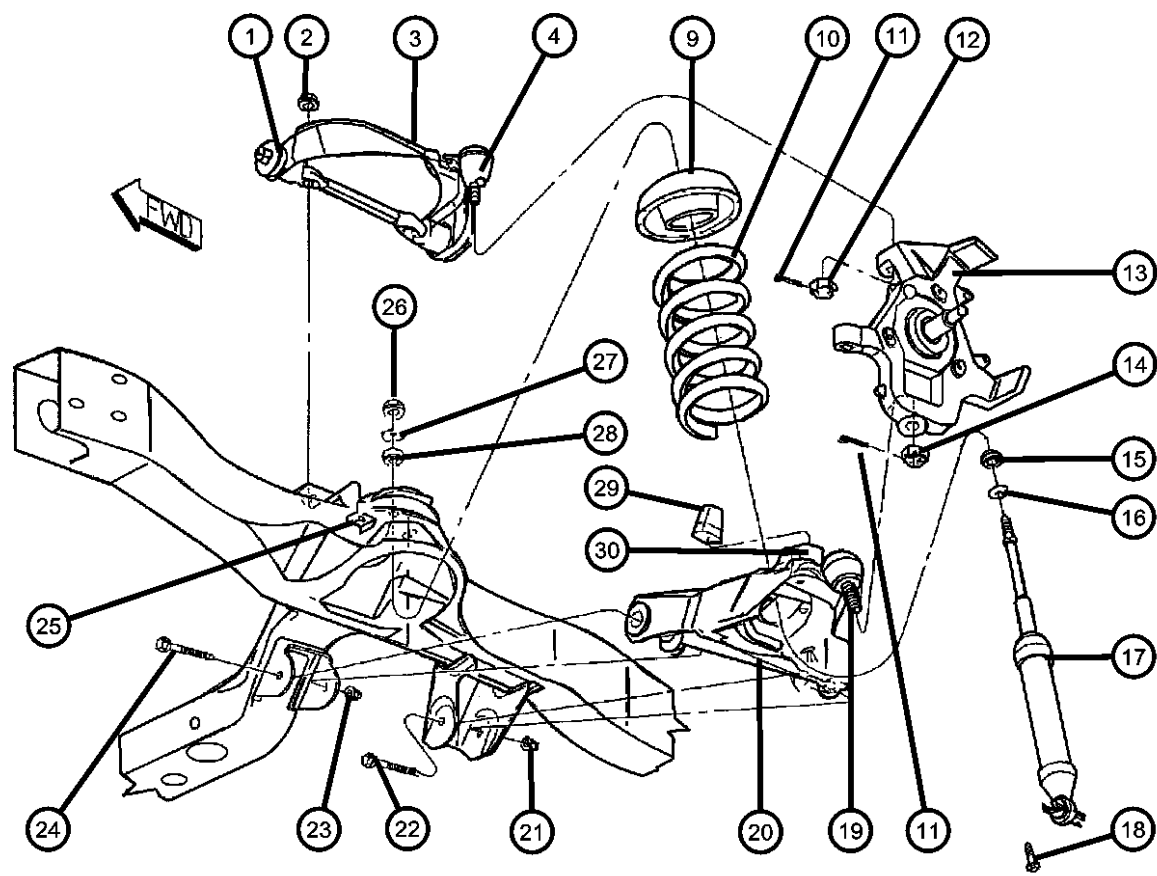

ITEM	PART NUMBER	QTY	LINE	SERIES	BODY	ENGINE	TRANS	TRIM	DESCRIPTION
	0SGR5609								Rancho Shock
	05011246AA	2	1			EM0			[SFB]
	0SGR5609								Rancho Shock
18	06503792	4	1						SCREW AND WASHER, Hex Head, M8-1.25x32.00, Shock Mounting, Lower
19	05103142AA	1	1						BALL JOINT PACKAGE, Lower Control ArmRight or Left
20									ARM, Control
	52059018	1	1						Complete Assembly, Right, Lower
	52059019	1	1						Complete Assembly, Left, Lower
	52106450AA	1	1						[SDE] Complete Assembly, Right, Lower
	52106451AA	1	1						[SDE] Complete Assembly, Left, Lower
21	06502697	2	1						NUT, Hex Flange Lock, M12x1.75, Rear Pivot Screw Mounting, Lower Control Arm
22	06503965	2	1						SCREW, Hex Flange Head, Rear Pivot, Lower Control Arm
23	06502698	2	1						NUT, Hex Flange Lock, Front Pivot Screw Mounting, Lower Control Arm
24	06505599AA	2	1						SCREW, Pilot Point, Front Pivot, Lower Control Arm
25	06036049AA	4	1						BOLT AND RETAINER, .562-18x2.07, Pivot Bar Mounting, Upper Control Arm
26	06504728	2							NUT AND WASHER, M10x1.5, Shock Mounting, Upper
27	52038805	2							RETAINER, Shock AbsorberUpper
28	52039478AA	4							GROMMET, Shock AbsorberUpper
29									BUMPER, Jounce
	52038816	2	1						[SDB], Lower Control Arm

DAKOTA (AN)

SERIES LINE  
 L = Regular Cab 1 = Lt. Duty DODGE 2WD  
 L = Club Cab 5 = Lt. Duty DODGE 4WD

BODY  
 31 = CLUB CAB 2-DR 6.5 FT BOX  
 61 = REG CAB 6.5 FT BOX  
 62 = REG CAB 8 FT BOX

ENGINE  
 EHC = "Magnum" 3.9L SMPI V6 Engine  
 ELF = 5.2L V8 MPI Engine  
 EML = 5.9L V8 MPI Engine  
 EPE = Engine - 2.5L Power Tech I-4 Cyl.

TRANSMISSION  
 DDC = 5-Speed HD Manual Transmission  
 DDK = 5-Speed HD Manual Transmission  
 DDQ = 5-Speed Manual Transmission  
 DGK = 4-Spd. Automatic 42RE Transmission  
 DGT = 4-Spd. Automatic 46RE Transmission  
 DGW = TRANSMISSION - 4-SPD. AUTOMATIC,44RE  
 DD0 = ALL 5 SPEED MANUAL TRANSMISSIONS  
 DG0 = TRANSMISSIONS - ALL AUTOMATIC

AR = use ase required - = Non illustrated part

1998 AN

Suspension,Front,Control Arms,Springs,Shocks,Knuckles-AN 1

Figure 2-110

ITEM	PART NUMBER	QTY	LINE	SERIES	BODY	ENGINE	TRANS	TRIM	DESCRIPTION
	52106438AA	2	1						[SDE], Lower Control Arm
30	52038815	1	1						CUP, Jounce BumperLower Control Arm

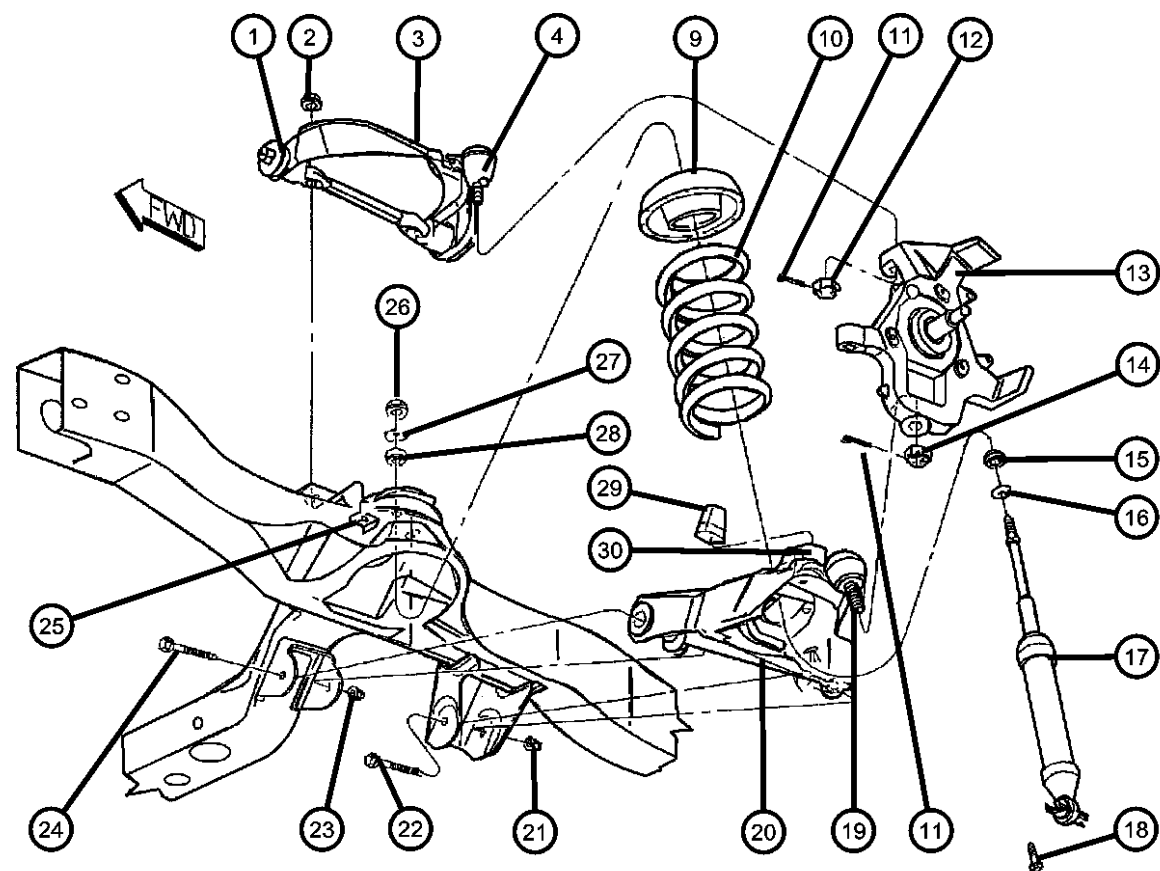

DAKOTA (AN)

SERIES LINE  
 L = Regular Cab 1 = Lt. Duty DODGE 2WD  
 L = Club Cab 5 = Lt. Duty DODGE 4WD

BODY  
 31 = CLUB CAB 2-DR 6.5 FT BOX  
 61 = REG CAB 6.5 FT BOX  
 62 = REG CAB 8 FT BOX

ENGINE  
 EHC = "Magnum" 3.9L SMPI V6 Engine  
 ELF = 5.2L V8 MPI Engine  
 EML = 5.9L V8 MPI Engine  
 EPE = Engine - 2.5L Power Tech I-4 Cyl.

TRANSMISSION  
 DDC = 5-Speed HD Manual Transmission  
 DDK = 5-Speed HD Manual Transmission  
 DDQ = 5-Speed Manual Transmission  
 DGK = 4-Spd. Automatic 42RE Transmission  
 DGT = 4-Spd. Automatic 46RE Transmission  
 DGW = TRANSMISSION - 4-SPD. AUTOMATIC,44RE  
 DD0 = ALL 5 SPEED MANUAL TRANSMISSIONS  
 DG0 = TRANSMISSIONS - ALL AUTOMATIC

AR = use ase required - = Non illustrated part

**Stabilizer Bar,Front-AN 1**  
**Figure 2-120**

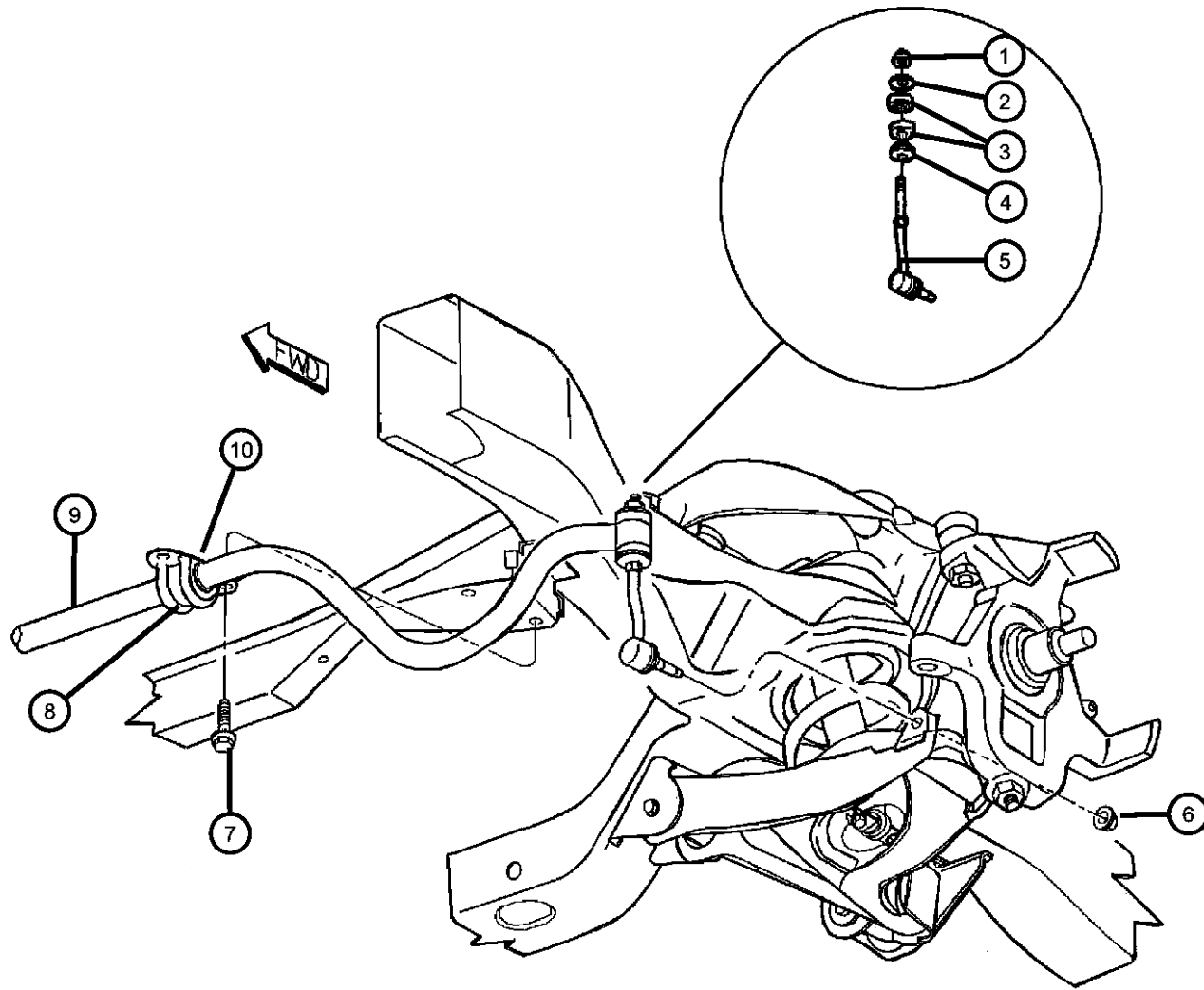

ITEM	PART NUMBER	QTY	LINE	SERIES	BODY	ENGINE	TRANS	TRIM	DESCRIPTION
Note:Sales Codes defined below; Check the VIN number for the proper sales code for the Stabilizer Bar EH0=Engines - All 3.9L V-6 Gas EL0=Engines - All 5.2L 8 Cylinder Gas EM0=Engines - All 5.9L 8 Cylinder Gas EP0=Engines - All 2.5L 4 Cylinder Gas LCA=Lower Control Arm									
1	06101687	2	1			EP0			NUT, Hex Lock, M10x1.5
		2	1			EH0, EL0, EM0			
2	52038115	2	1			EP0			RETAINER, Stabilizer Bar Grommet Large Hole
		2	1			EH0, EL0, EM0			Large Hole
	52038116	2	1			EP0			Small Hole
		2	1			EH0, EL0, EM0			Small Hole
3	52037916	4	1			EP0			GROMMET, Link
		4	1			EH0, EL0, EM0			
4	52038736	2	1			EP0			LINK, Sway Eliminator
		2	1			EH0, EL0, EM0			
5	06101696	2	1						NUT, Stabilizer Link to LCA, Mounting
6	06504010	4	1						SCREW AND WASHER, Hex Head, M10x1.50x35, Stabilizer Retainer to Frame
7	52037710	2	1			EP0			RETAINER, Stabilizer Bar Grommet Bushing

**DAKOTA (AN)**

SERIES      LINE  
 L = Regular Cab    1 = Lt. Duty DODGE 2WD  
 L = Club Cab        5 = Lt. Duty DODGE 4WD

BODY  
 31 = CLUB CAB 2-DR 6.5 FT BOX  
 61 = REG CAB 6.5 FT BOX  
 62 = REG CAB 8 FT BOX

ENGINE  
 EHC = "Magnum" 3.9L SMPI V6 Engine  
 ELF = 5.2L V8 MPI Engine  
 EML = 5.9L V8 MPI Engine  
 EPE = Engine - 2.5L Power Tech I-4 Cyl.

TRANSMISSION  
 DDC = 5-Speed HD Manual Transmission  
 DDK = 5-Speed HD Manual Transmission  
 DDQ = 5-Speed Manual Transmission  
 DGK = 4-Spd. Automatic 42RE Transmission  
 DGT = 4-Spd. Automatic 46RE Transmission  
 DGW = TRANSMISSION - 4-SPD. AUTOMATIC,44RE  
 DD0 = ALL 5 SPEED MANUAL TRANSMISSIONS  
 DG0 = TRANSMISSIONS - ALL AUTOMATIC

AR = use ase required    - = Non illustrated part

Stabilizer Bar,Front-AN 1  
Figure 2-120

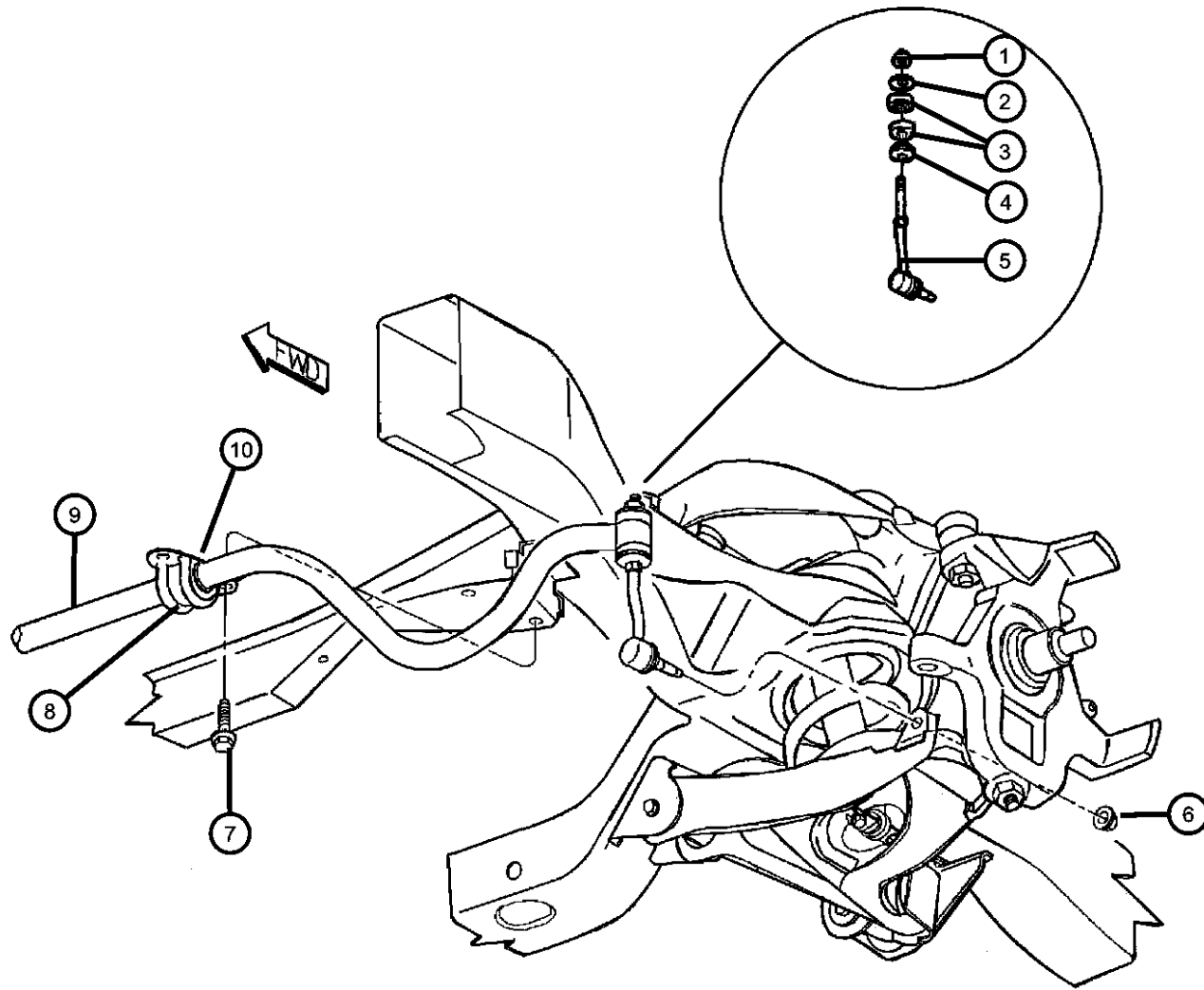

ITEM	PART NUMBER	QTY	LINE	SERIES	BODY	ENGINE	TRANS	TRIM	DESCRIPTION
8		2	1			EH0, ELO, EMO			Bushing
	52038864	1	1			EP0			STABILIZER BAR, Front
	52038866	1	1			EH0, ELO, EMO			
9									BUSHING, Stabilizer Bar
	52038975	2	1			EP0			
	52039357	2	1			EH0, ELO, EMO			

DAKOTA (AN)

SERIES      LINE  
L = Regular Cab    1 = Lt. Duty DODGE 2WD  
L = Club Cab        5 = Lt. Duty DODGE 4WD

BODY  
31 = CLUB CAB 2-DR 6.5 FT BOX  
61 = REG CAB 6.5 FT BOX  
62 = REG CAB 8 FT BOX

ENGINE  
EHC = "Magnum" 3.9L SMPI V6 Engine  
ELF = 5.2L V8 MPI Engine  
EML = 5.9L V8 MPI Engine  
EPE = Engine - 2.5L Power Tech I-4 Cyl.

TRANSMISSION  
DDC = 5-Speed HD Manual Transmission  
DDK = 5-Speed HD Manual Transmission  
DDQ = 5-Speed Manual Transmission  
DGK = 4-Spd. Automatic 42RE Transmission  
DGT = 4-Spd. Automatic 46RE Transmission  
DGW = TRANSMISSION - 4-SPD. AUTOMATIC,44RE  
DD0 = ALL 5 SPEED MANUAL TRANSMISSIONS  
DG0 = TRANSMISSIONS - ALL AUTOMATIC

AR = use ase required - = Non illustrated part



Suspension,Front,Control Arms,Shocks,Knuckles-AN 5

Figure 2-130

ITEM	PART NUMBER	QTY	LINE	SERIES	BODY	ENGINE	TRANS	TRIM	DESCRIPTION
------	-------------	-----	------	--------	------	--------	-------	------	-------------

Note:Sales Codes defined below;  
 Check the VIN number for the proper sales code for the Shock Absorbers  
 EH0=Engines - All 3.9L V6 Cylinder Gas  
 EL0=Engines - All 5.2L 8 Cylinder Gas  
 EM0=Engines - All 5.9L 8 Cylinder Gas  
 LCA=Lower Control Arm

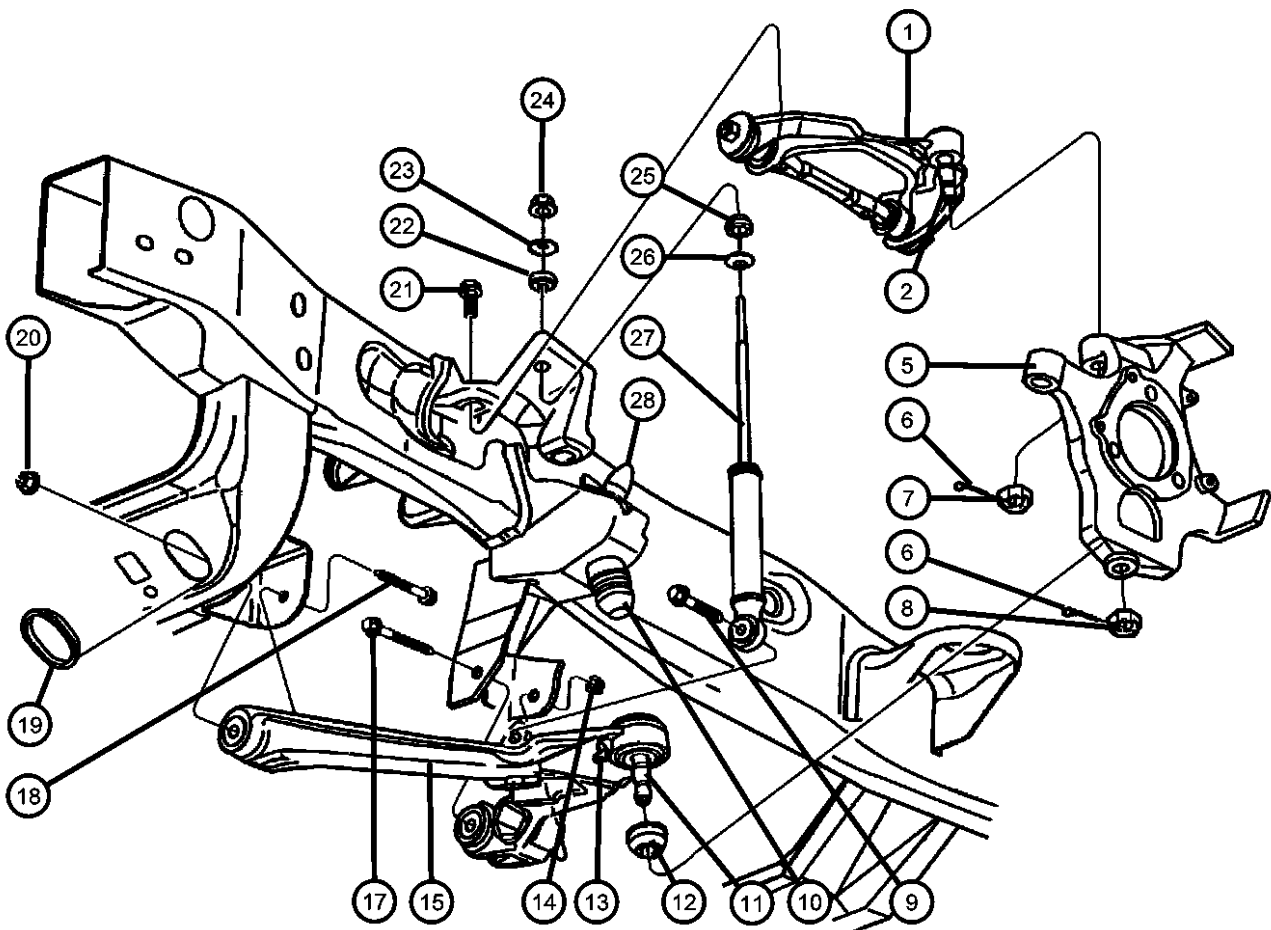

1									ARM, Control
	52039410	1	5						Complete Assembly, Upper Right
	52039411	1	5						Complete Assembly, Upper Left
2	05104788AB	1	5						BALL JOINT PACKAGE, Upper Control ArmRight or Left
-3	03815704	2	5						RETAINER, Control Arm Bushing
-4	06503975	2	5						NUT, Hex Lock, M14 x 2.00, Bushing, Upper Control Arm
5									KNUCKLE, Front
	52038688	1	5						Right
	52038689	1	5						Left
6	00120123	2							PIN, Cotter, Ball Joint Stud, Upper or Lower
7	06502749	2							NUT, Castle, M14x1.5, Mounting, Upper Control Arm Ball Joint
8	06504705	2	5						NUT, Hex, M14-2, Mounting, Lower Control Arm Ball Joint
9	06101971	2	5						SCREW AND WASHER, Front Shock to LCA, Mounting
10	52038558	2	5						BUMPER, JounceFront Suspension
11	52038886	1	5						BALL JOINT, Lower Control ArmRight or Left
12	02269214	2	5						SEAL, Ball Joint
13	06030099	1	5						FITTING, Ball Joint, ZircLower Control Arm
14	06502698	2	5						NUT, Hex Flange Lock, Rear Pivot Screw Mounting, Lower Control Arm
15									ARM, Control

DAKOTA (AN)

SERIES LINE  
 L = Regular Cab 1 = Lt. Duty DODGE 2WD  
 L = Club Cab 5 = Lt. Duty DODGE 4WD

BODY  
 31 = CLUB CAB 2-DR 6.5 FT BOX  
 61 = REG CAB 6.5 FT BOX  
 62 = REG CAB 8 FT BOX

ENGINE  
 EHC = "Magnum" 3.9L SMPI V6 Engine  
 ELF = 5.2L V8 MPI Engine  
 EML = 5.9L V8 MPI Engine  
 EPE = Engine - 2.5L Power Tech I-4 Cyl.

TRANSMISSION  
 DDC = 5-Speed HD Manual Transmission  
 DDK = 5-Speed HD Manual Transmission  
 DDQ = 5-Speed Manual Transmission  
 DGK = 4-Spd. Automatic 42RE Transmission  
 DGT = 4-Spd. Automatic 46RE Transmission  
 DGW = TRANSMISSION - 4-SPD. AUTOMATIC,44RE  
 DD0 = ALL 5 SPEED MANUAL TRANSMISSIONS  
 DG0 = TRANSMISSIONS - ALL AUTOMATIC

AR = use ase required - = Non illustrated part

1998 AN

**Suspension,Front,Control Arms,Shocks,Knuckles-AN 5**  
**Figure 2-130**

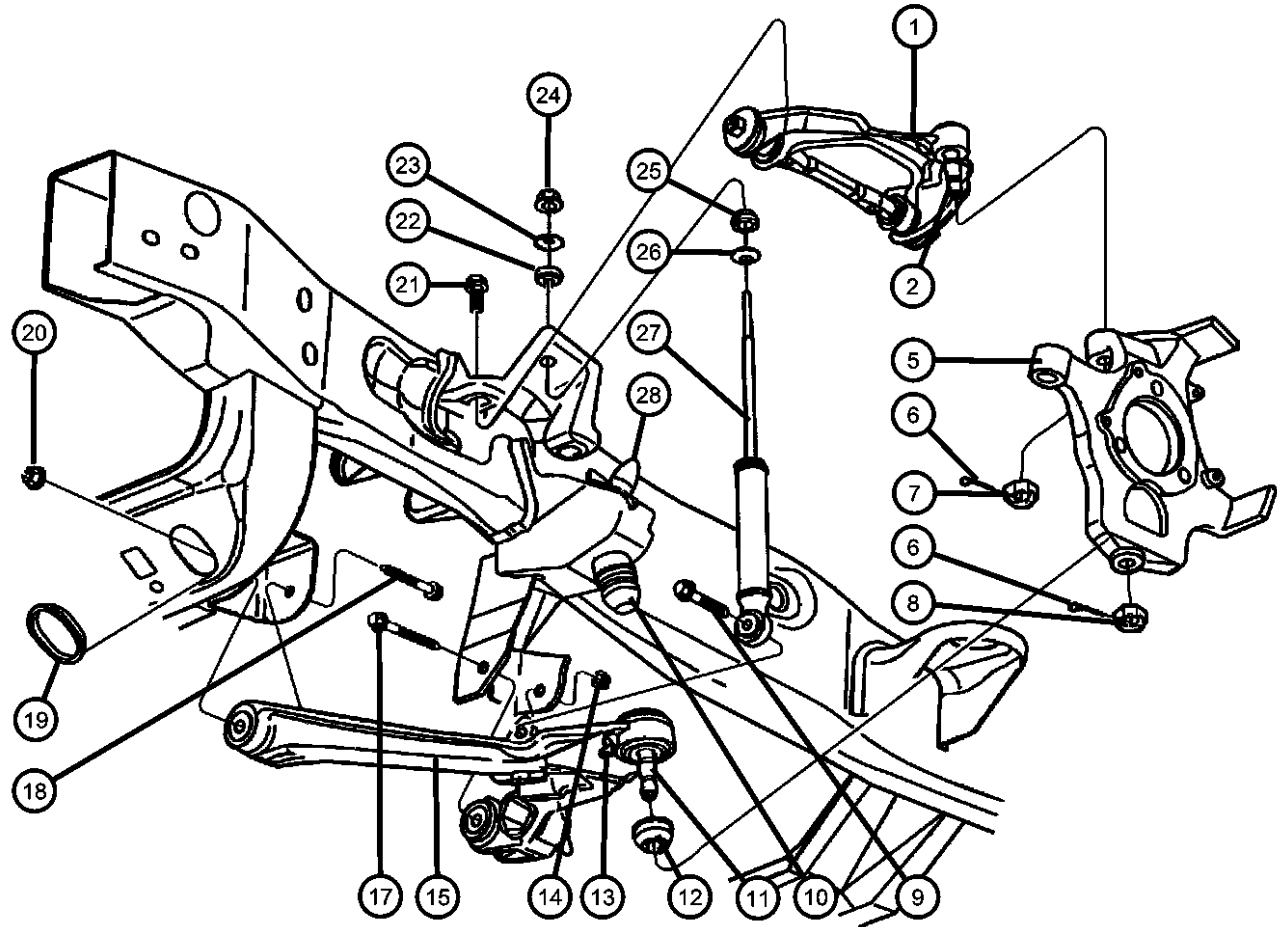

ITEM	PART NUMBER	QTY	LINE	SERIES	BODY	ENGINE	TRANS	TRIM	DESCRIPTION
	52038902AC	1	5						Complete Assembly, Lower Right
	52038903	1	5						Complete Assembly, Lower Left
-16	09412281	1	5						PIN, Spring, .250 x 1.00Torsion Bar Locator
17	06504109	2	5						SCREW, Hex Flange Head, M14x2x110, Rear Pivot, Lower Control Arm
18	06503993	2	5						SCREW, Hex Flange Head, M12X1.75X110.00, Front Pivot, Lower Control Arm
19	52038858	2	5						PLUG, Steering Gear Support Crossmember, Mounting
20	06502697	2	5						NUT, Hex Flange Lock, M12x1.75, Front Pivot Screw Mounting, Lower Control Arm
21	06504229	4	5						SCREW AND WASHER, Hex Flange Head, M14X2.00X110.00, Pivot Bar Mounting, Upper Control Arm
22	52039478AA	4							GROMMET, Shock AbsorberUpper or Lower
23	52038805	2							RETAINER, Shock AbsorberUpper
24	06504728	2							NUT AND WASHER, M10x1.5Shock Mounting Upper
25	52039478AA	4							GROMMET, Shock AbsorberUpper or Lower
26	52038809	2							RETAINER, Shock AbsorberLower
27									SHOCK ABSORBER PACKAGE, Suspension, Front
	04883070	2	5			EHO			[Z5A]
	0SGR5609								Rancho Shock
	0SG23387								Mopar V-Line Alternative Part
	04883071	2	5			ELO, EM0			[Z5A]
	0SGR5019								Rancho Shock
	0SG23387								Mopar V-Line Alternative Part

**DAKOTA (AN)**

SERIES      LINE  
L = Regular Cab    1 = Lt. Duty DODGE 2WD  
L = Club Cab        5 = Lt. Duty DODGE 4WD

BODY  
31 = CLUB CAB 2-DR 6.5 FT BOX  
61 = REG CAB 6.5 FT BOX  
62 = REG CAB 8 FT BOX

ENGINE  
EHC = "Magnum" 3.9L SMPI V6 Engine  
ELF = 5.2L V8 MPI Engine  
EML = 5.9L V8 MPI Engine  
EPE = Engine - 2.5L Power Tech I-4 Cyl.

TRANSMISSION  
DDC = 5-Speed HD Manual Transmission  
DDK = 5-Speed HD Manual Transmission  
DDQ = 5-Speed Manual Transmission  
DGK = 4-Spd. Automatic 42RE Transmission  
DGT = 4-Spd. Automatic 46RE Transmission  
DGW = TRANSMISSION - 4-SPD. AUTOMATIC,44RE  
DD0 = ALL 5 SPEED MANUAL TRANSMISSIONS  
DG0 = TRANSMISSIONS - ALL AUTOMATIC

AR = use ase required    - = Non illustrated part

Suspension,Front,Control Arms,Shocks,Knuckles-AN 5

Figure 2-130

ITEM	PART NUMBER	QTY	LINE	SERIES	BODY	ENGINE	TRANS	TRIM	DESCRIPTION
	04883072AB	2	5			EHO			[Z5B,Z5C]
	0SGR5019								Rancho Shock
	04883073AB	2	5			EL0, EM0			[Z5B,Z5C]
	0SGR5019								Rancho Shock
28	52038781	2	5						BUMPER, JounceFront Suspension Rebound

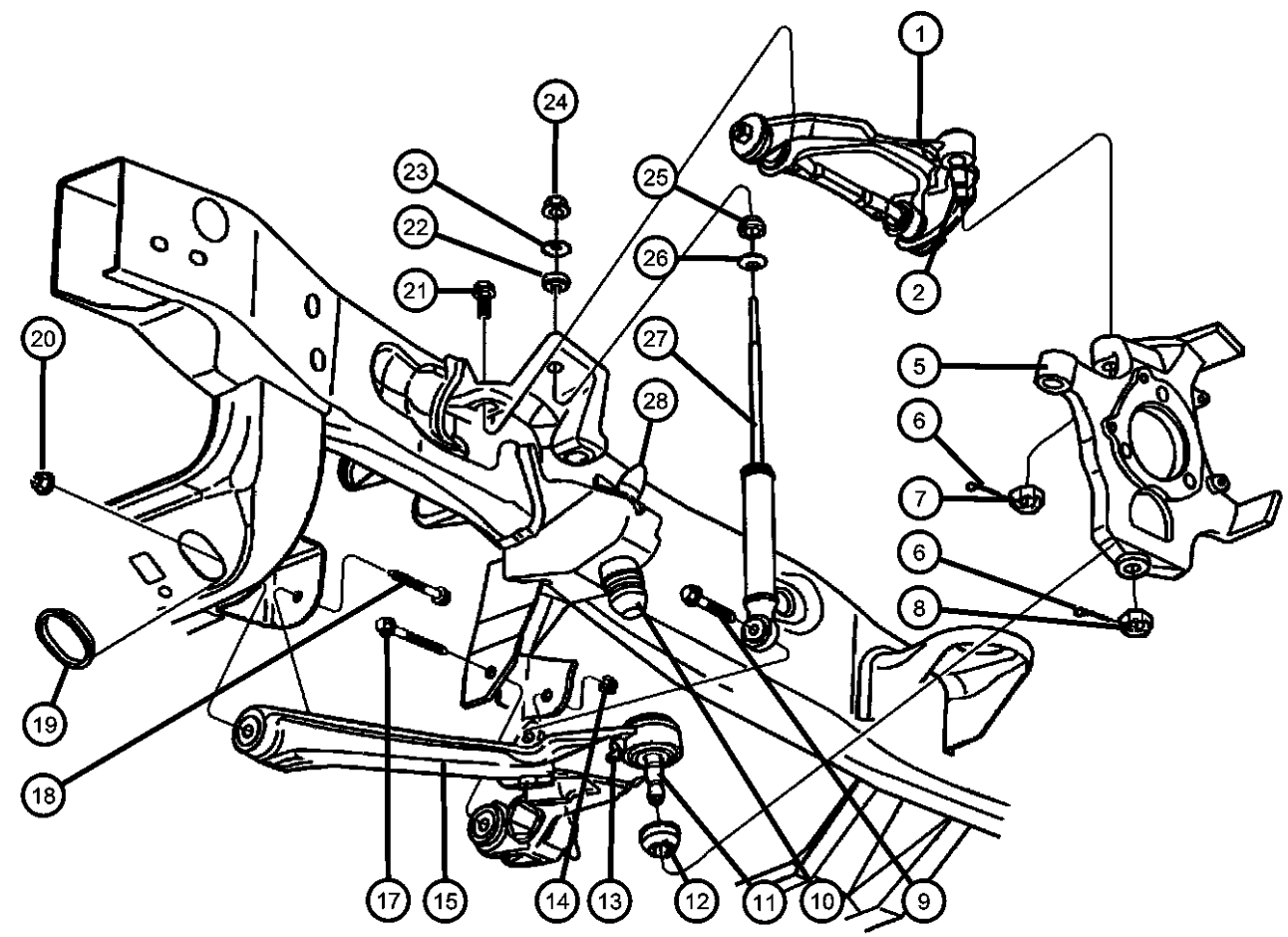

DAKOTA (AN)

SERIES	LINE	BODY	ENGINE	TRANSMISSION
L = Regular Cab	1 = Lt. Duty DODGE 2WD	31 = CLUB CAB 2-DR 6.5 FT BOX	EHC = "Magnum" 3.9L SMPI V6 Engine	DDC = 5-Speed HD Manual Transmission
L = Club Cab	5 = Lt. Duty DODGE 4WD	61 = REG CAB 6.5 FT BOX	ELF = 5.2L V8 MPI Engine	DDK = 5-Speed HD Manual Transmission
		62 = REG CAB 8 FT BOX	EML = 5.9L V8 MPI Engine	DDQ = 5-Speed Manual Transmission
			EPE = Engine - 2.5L Power Tech I-4 Cyl.	DGK = 4-Spd. Automatic 42RE Transmission
				DGT = 4-Spd. Automatic 46RE Transmission
				DGW = TRANSMISSION - 4-SPD. AUTOMATIC,44RE
				DD0 = ALL 5 SPEED MANUAL TRANSMISSIONS
				DG0 = TRANSMISSIONS - ALL AUTOMATIC

AR = use ase required - = Non illustrated part

**Stabilizer Bar and Torsion Bar,Front-AN 5**  
**Figure 2-140**

ITEM	PART NUMBER	QTY	LINE	SERIES	BODY	ENGINE	TRANS	TRIM	DESCRIPTION
------	-------------	-----	------	--------	------	--------	-------	------	-------------

Note: Sales Codes defined below;  
 Check the Vin number for the proper sales codes for the Torsion Bars.  
 LCA=Lower Control Arm

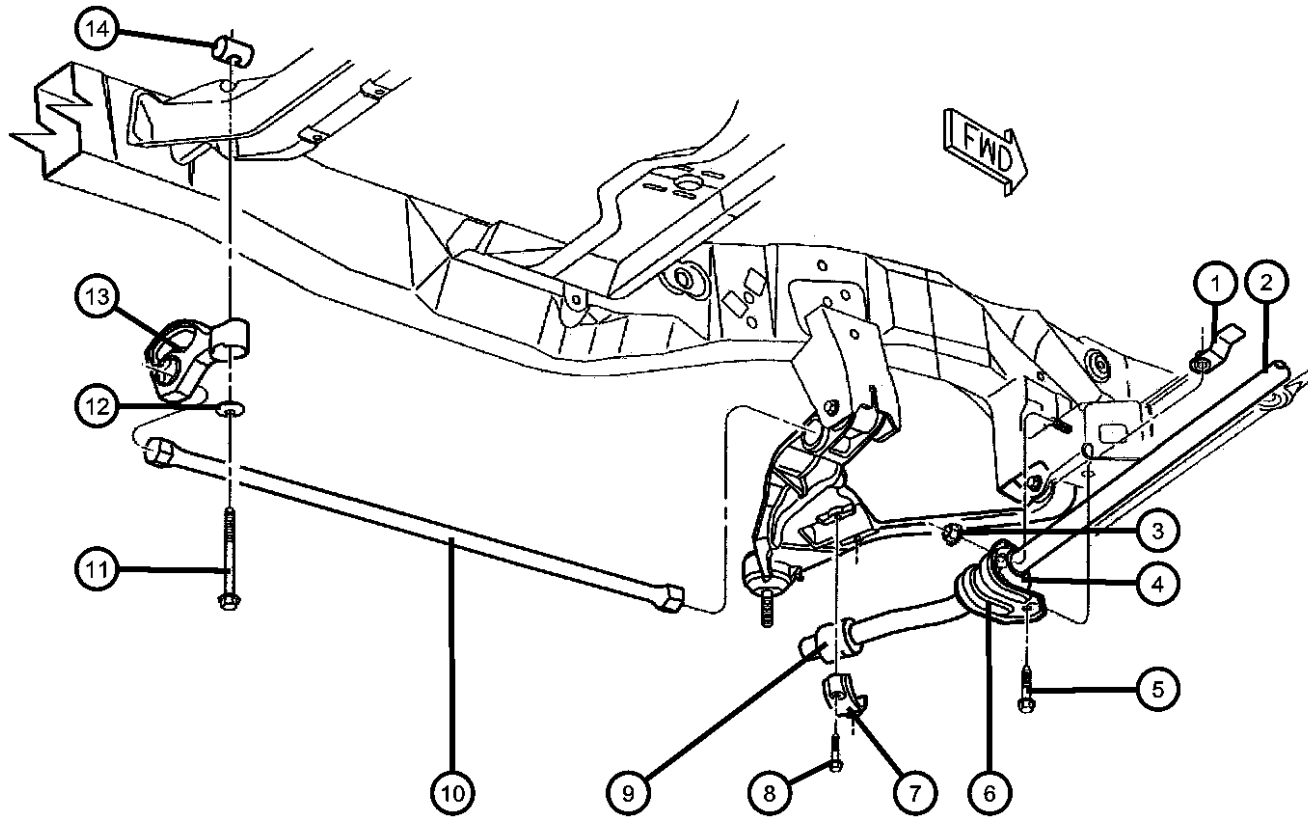

1	06504413	2	5						NUT AND RETAINER, Hex Flange Locking, M12x1.75, Stabilizer Bar Retainer to Crossmember, Mounting
2	52039353	1	5						BAR, Front Sway
3	52039353	1							NUT, Hex Lock, M14 x 2.00, Upper Sill Bushing Mounting, (NOT SERVICED)
4	52038760	2	5						BUSHING, Stabilizer Bar Inner
5	06502559	2	5						SCREW, Hex Flange Head, M12x1.75x40.00, Stabilizer Bar Retainer, Mounting
6	52038796	2	5						RETAINER, Stabilizer Bar Grommet, Bushing, Inner
7	52038825	2	5						CLAMP, Stabilizer Shaft Bushing, Stabilizer Bar to LCA, Mounting
8	06101980	4	5						SCREW AND WASHER, Hex Head, M8x1.25x45, Stabilizer Bar to Clamp, Mounting
9	52038777	2	5						CUSHION, Sway Eliminator Outer
10									BAR, Torsion
	04322514	1	5						[ZRD], Right
	04322515	1	5						[ZCD], Left
	04322516	1	5						[ZRE], Right
	04322517	1	5						[ZCE], Left
11	03815680	2	5						BOLT, Front Spring Rear Anchor, Torsion Bar Rear Anchor
12	04014100	2	5						BEARING, Torsion Bar, Torsion Bar Rear Anchor Adjust Bolt
13	52038973	2	5						ANCHOR, Torsion Bar, Front Adjustment
14	04322561	2	5						SWIVEL, Torsion Bar, Torsion Bar Rear Anchor Adjust Bolt

**DAKOTA (AN)**

SERIES      LINE  
 L = Regular Cab    1 = Lt. Duty DODGE 2WD  
 L = Club Cab        5 = Lt. Duty DODGE 4WD

BODY  
 31 = CLUB CAB 2-DR 6.5 FT BOX  
 61 = REG CAB 6.5 FT BOX  
 62 = REG CAB 8 FT BOX

ENGINE  
 EHC = "Magnum" 3.9L SMPI V6 Engine  
 ELF = 5.2L V8 MPI Engine  
 EML = 5.9L V8 MPI Engine  
 EPE = Engine - 2.5L Power Tech I-4 Cyl.

TRANSMISSION  
 DDC = 5-Speed HD Manual Transmission  
 DDK = 5-Speed HD Manual Transmission  
 DDQ = 5-Speed Manual Transmission  
 DGK = 4-Spd. Automatic 42RE Transmission  
 DGT = 4-Spd. Automatic 46RE Transmission  
 DGW = TRANSMISSION - 4-SPD. AUTOMATIC, 44RE  
 DD0 = ALL 5 SPEED MANUAL TRANSMISSIONS  
 DG0 = TRANSMISSIONS - ALL AUTOMATIC

AR = use ase required    - = Non illustrated part

1998 AN

Shaft,Front Axle Drive  
Figure 2-210

ITEM	PART NUMBER	QTY	LINE	SERIES	BODY	ENGINE	TRANS	TRIM	DESCRIPTION
1	04883326	2	5						BOOT KIT, Half Shaft, Inner, with Clamps, Right or Left
2	04882691	2	5						SHAFT, Axle Half, with Boots, Right or Left
3	06033288	12	5						Bolt, Hex Flange Head, .437-14x1.00
4	04883327	2	5						BOOT KIT, Half Shaft, Outer, with Clamps, Right or Left
5	06502293	2	5						WASHER, Flat, M23x43x4
6	06502294	2	5						NUT, Hex Flange, M22x1.25
7	04293167	2	5						NUT AND WASHER PACKAGE, Front Hub
8	06500336	2	5						PIN, Cotter, M5x36.00

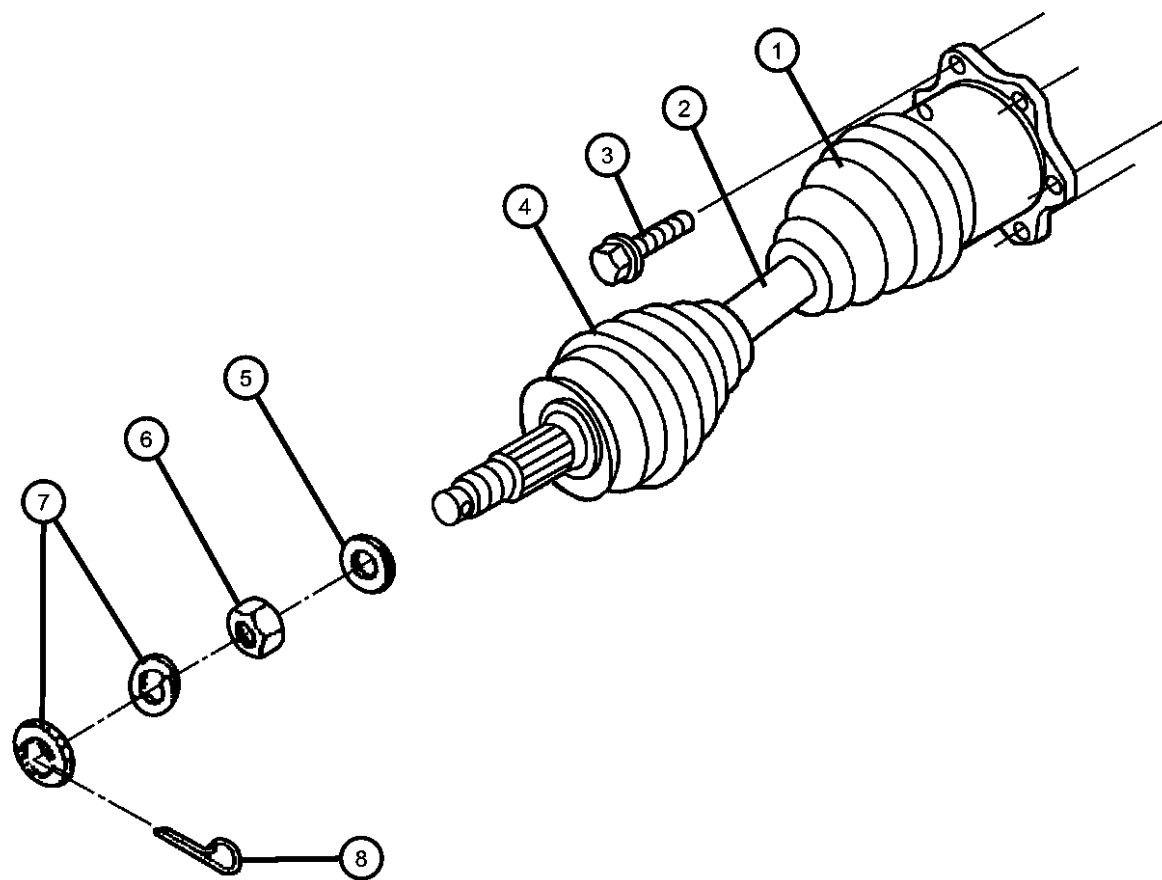

**DAKOTA (AN)**

SERIES      LINE  
L = Regular Cab    1 = Lt. Duty DODGE 2WD  
L = Club Cab        5 = Lt. Duty DODGE 4WD

BODY  
31 = CLUB CAB 2-DR 6.5 FT BOX  
61 = REG CAB 6.5 FT BOX  
62 = REG CAB 8 FT BOX

ENGINE  
EHC = "Magnum" 3.9L SMPI V6 Engine  
ELF = 5.2L V8 MPI Engine  
EML = 5.9L V8 MPI Engine  
EPE = Engine - 2.5L Power Tech I-4 Cyl.

TRANSMISSION  
DDC = 5-Speed HD Manual Transmission  
DDK = 5-Speed HD Manual Transmission  
DDQ = 5-Speed Manual Transmission  
DGK = 4-Spd. Automatic 42RE Transmission  
DGT = 4-Spd. Automatic 46RE Transmission  
DGW = TRANSMISSION - 4-SPD. AUTOMATIC,44RE  
DD0 = ALL 5 SPEED MANUAL TRANSMISSIONS  
DG0 = TRANSMISSIONS - ALL AUTOMATIC

AR = use ase required - = Non illustrated part

Housing,Front Axle  
Figure 2-310

ITEM	PART NUMBER	QTY	LINE	SERIES	BODY	ENGINE	TRANS	TRIM	DESCRIPTION
------	-------------	-----	------	--------	------	--------	-------	------	-------------

Note: Sales Codes defined below;  
 EL0= Engines - All 5.2L 8 Cylinder Gas  
 EM0=Engines - All 5.9L 8 Cylinder Gas

1	J5352955	1	5						VENT, Axle
2	34175327	1							CLIP, Conduit Convoluted
3	52098870	1	5						HOSE, Axle Vent, Includes Item 1
4	04882700	1	5						SHAFT, AxleRight
5	05252775	2	5						SNAP RING, Axle ShaftRight or Left
6	04856336	2	5						SEAL, Axle Drive ShaftRight or Left
7	J8134586	2	5						BEARING, Axle ShaftRight or Left
8	83504653	1	5						VENT, Axle
9	04882706	1	5						HOUSING, Axle, Includes Item 10
-10	06035985AA	4	5						BOLT, Differential, Carrier Bearing Cap, Mounting
11	04882701	1	5						SHAFT, AxleLeft
12	04882707	1	5						COVER, Differential, Includes Items 13,14
13	05252504	1	5						PLUG, Differential Cover
14	05013425AA	1	5						BOLT KIT, Cover, Differential
15	04318025	1	5			EL0, EM0			SEALANT, RTV, Cover, Differential

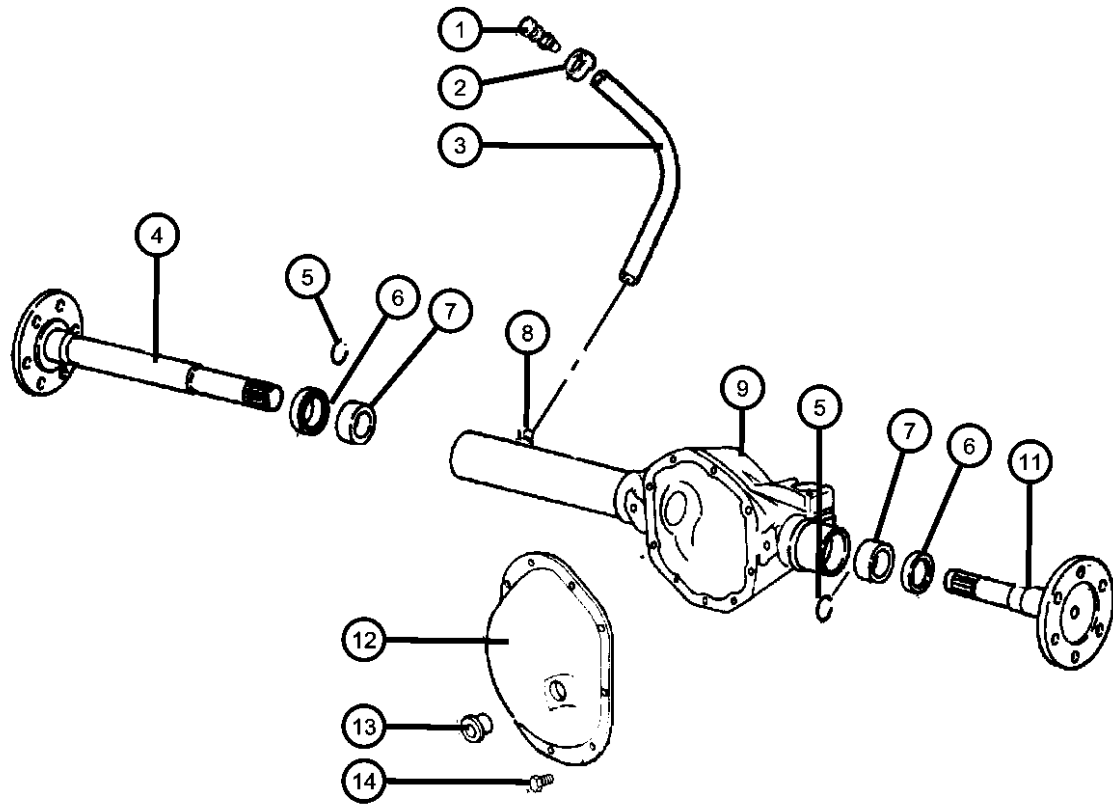

DAKOTA (AN)

SERIES LINE  
 L = Regular Cab 1 = Lt. Duty DODGE 2WD  
 L = Club Cab 5 = Lt. Duty DODGE 4WD

BODY  
 31 = CLUB CAB 2-DR 6.5 FT BOX  
 61 = REG CAB 6.5 FT BOX  
 62 = REG CAB 8 FT BOX

ENGINE  
 EHC = "Magnum" 3.9L SMPI V6 Engine  
 ELF = 5.2L V8 MPI Engine  
 EML = 5.9L V8 MPI Engine  
 EPE = Engine - 2.5L Power Tech I-4 Cyl.

TRANSMISSION  
 DDC = 5-Speed HD Manual Transmission  
 DDK = 5-Speed HD Manual Transmission  
 DDQ = 5-Speed Manual Transmission  
 DGK = 4-Spd. Automatic 42RE Transmission  
 DGT = 4-Spd. Automatic 46RE Transmission  
 DGW = TRANSMISSION - 4-SPD. AUTOMATIC, 44RE  
 DD0 = ALL 5 SPEED MANUAL TRANSMISSIONS  
 DG0 = TRANSMISSIONS - ALL AUTOMATIC

AR = use ase required - = Non illustrated part

1998 AN

**Axle Assembly,Front  
Figure 2-410**

ITEM	PART NUMBER	QTY	LINE	SERIES	BODY	ENGINE	TRANS	TRIM	DESCRIPTION
------	-------------	-----	------	--------	------	--------	-------	------	-------------

Note:Sales Codes defined below;  
DMD = Axle Ratio - 3.55  
DMH = Axle Ratio - 3.92

1									AXLE, Front
	52070001	1	5						[DMD]
	04874468								Mopar SAE 80W-90 Gear Lube Quart Bottle
	68003054AA								Mopar SAE 80W-90 Gear Lube 16 Gallon Keg
	52070002	1	5						[DMH]
	04874468								Mopar SAE 80W-90 Gear Lube Quart Bottle
	68003054AA								Mopar SAE 80W-90 Gear Lube 16 Gallon Keg

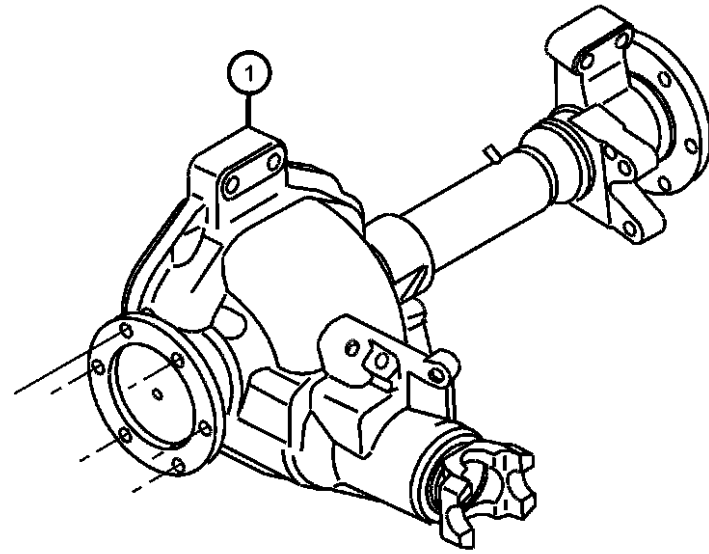

**DAKOTA (AN)**

SERIES	LINE	BODY	ENGINE	TRANSMISSION
L = Regular Cab	1 = Lt. Duty DODGE 2WD	31 = CLUB CAB 2-DR 6.5 FT BOX	EHC = "Magnum" 3.9L SMPI V6 Engine	DDC = 5-Speed HD Manual Transmission
L = Club Cab	5 = Lt. Duty DODGE 4WD	61 = REG CAB 6.5 FT BOX	ELF = 5.2L V8 MPI Engine	DDK = 5-Speed HD Manual Transmission
		62 = REG CAB 8 FT BOX	EML = 5.9L V8 MPI Engine	DDQ = 5-Speed Manual Transmission
			EPE = Engine - 2.5L Power Tech I-4 Cyl.	DGK = 4-Spd. Automatic 42RE Transmission
				DGT = 4-Spd. Automatic 46RE Transmission
				DGW = TRANSMISSION - 4-SPD. AUTOMATIC,44RE
				DD0 = ALL 5 SPEED MANUAL TRANSMISSIONS
				DG0 = TRANSMISSIONS - ALL AUTOMATIC

AR = use ase required - = Non illustrated part

1998 AN

**Differential,Front Axle  
Figure 2-610**

ITEM	PART NUMBER	QTY	LINE	SERIES	BODY	ENGINE	TRANS	TRIM	DESCRIPTION
------	-------------	-----	------	--------	------	--------	-------	------	-------------

Note:Sales Codes defined below;  
DMD = Axle Ratio - 3.55  
DMH = Axle Ratio - 3.92

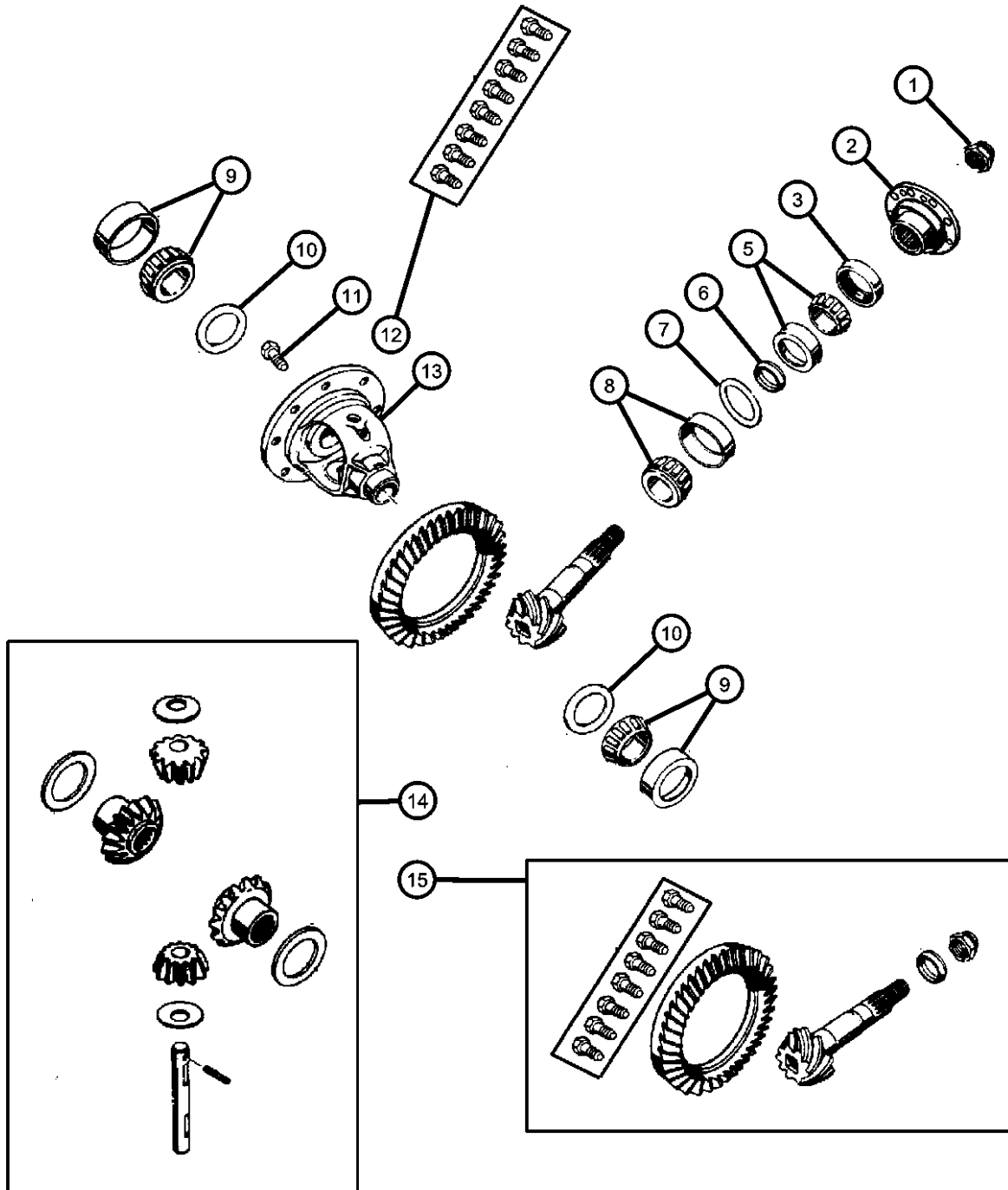

1	04720895	1	5						NUT, Pinion Yoke
2	04883962AA	1	5						YOKE, Axle
3	04883966AA	1	5						SEAL, Drive Pinion
4	04883964AA	1	5						O RING, Pinion Flange, Fits Over Hub of Pinion Flange
5	05252508	1	5						BEARING, Drive Pinion, Consists of Bearing and Cup, Front
6	J3175779	1	5						SPACER, Drive Pinion Bearing, Crush
7	04882697	1	5						SHIM KIT, Pinion Shaft
8	05252507	1	5						BEARING, Drive Pinion, Consists of Bearing and Cup, Rear
9	J8126500	1	5						BEARING, Differential, Consists of 2 Bearings and 2 Cups
10	04720863	1	5						SHIM KIT, Differential
11	05252503	10	5						SCREW, Drive Gear
12	04720891	1	5						BOLT KIT, Consists of 10-5252503 Screws
13	04882710	1	5						CASE, Differential, Includes items 11 and 13
14	04882696	1	5						GEAR KIT, Center Differential
15									GEAR KIT, Ring And Pinion
	04761676	1	5						[DMD]
	04882716	1	5						[DMH]

**DAKOTA (AN)**

SERIES      LINE  
L = Regular Cab    1 = Lt. Duty DODGE 2WD  
L = Club Cab        5 = Lt. Duty DODGE 4WD

BODY  
31 = CLUB CAB 2-DR 6.5 FT BOX  
61 = REG CAB 6.5 FT BOX  
62 = REG CAB 8 FT BOX

ENGINE  
EHC = "Magnum" 3.9L SMPI V6 Engine  
ELF = 5.2L V8 MPI Engine  
EML = 5.9L V8 MPI Engine  
EPE = Engine - 2.5L Power Tech I-4 Cyl.

TRANSMISSION  
DDC = 5-Speed HD Manual Transmission  
DDK = 5-Speed HD Manual Transmission  
DDQ = 5-Speed Manual Transmission  
DGK = 4-Spd. Automatic 42RE Transmission  
DGT = 4-Spd. Automatic 46RE Transmission  
DGW = TRANSMISSION - 4-SPD. AUTOMATIC,44RE  
DD0 = ALL 5 SPEED MANUAL TRANSMISSIONS  
DG0 = TRANSMISSIONS - ALL AUTOMATIC

AR = use ase required    - = Non illustrated part

1998 AN



Skid Plate,Front Axle  
Figure 2-810

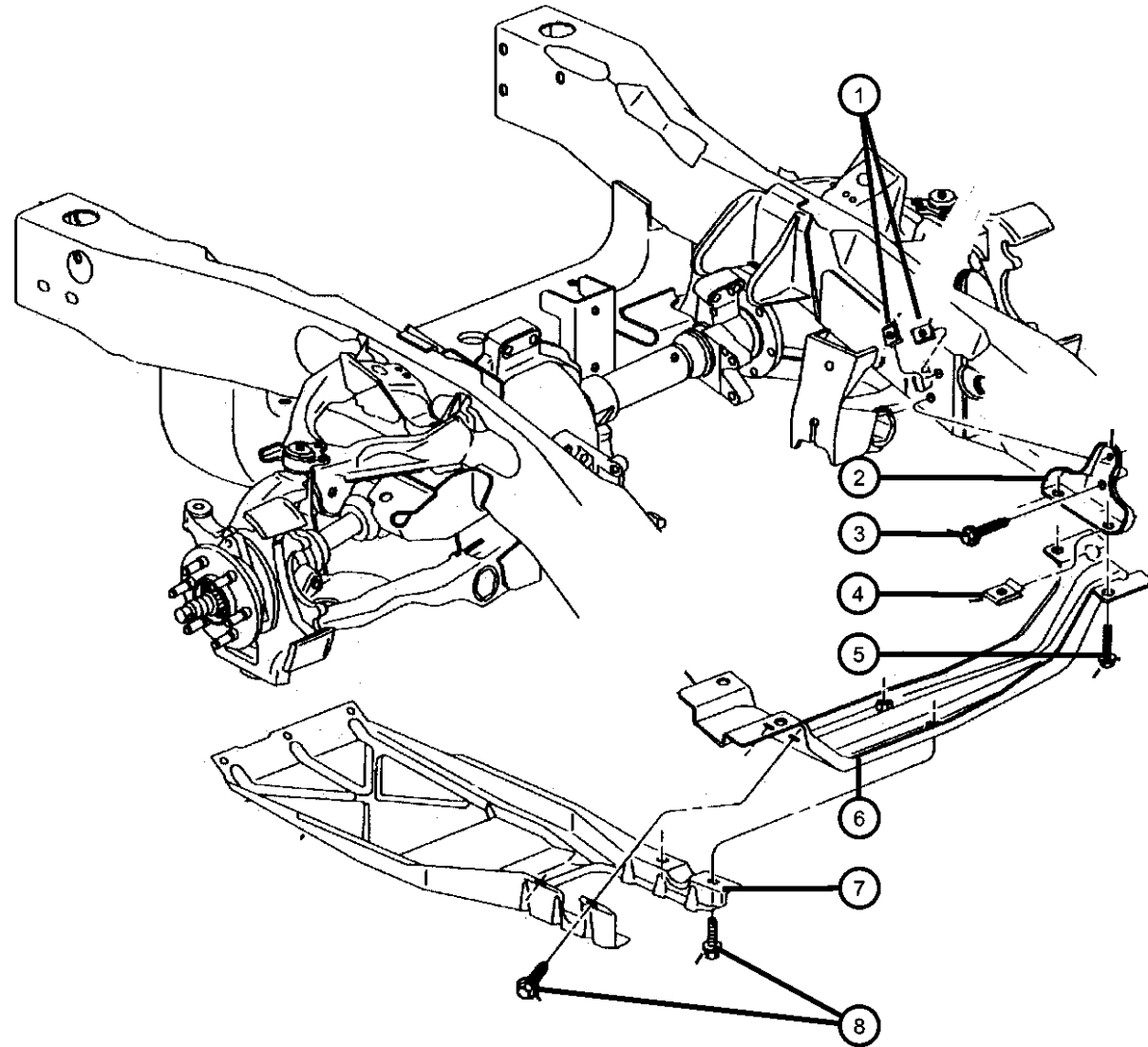

ITEM	PART NUMBER	QTY	LINE	SERIES	BODY	ENGINE	TRANS	TRIM	DESCRIPTION
1	06101340	4	5						U-NUT, M10-1.50, Skid Plate Bracket to Frame, Mounting
2	52019850	2	5						BRACKET, Skid PlateRight or Left
3	52019850	2							SCREW AND WASHER, Hex Head, M10x1.5x40, Skid Plate Bracket to Frame Mounting-Quantity 4, (NOT SERVICED)
4	06101340	4	5						U-NUT, M10-1.50, Skid Plate Crossmember to Skid Plate Bracket, Mounting
5	06101340	4							SCREW AND WASHER, Hex Head, M10x1.5x40, Skid Plate Crossmember to Skid Plate Bracket Mounting-Quantity 4, (NOT SERVICED)
6	52058897	1	5						CROSSMEMBER, Front AxleSkid Plate
7	52019981	1	5						SKID PLATE, Front
8	52019981	1							SCREW AND WASHER, Hex Head, M10x1.5x30, Skid Plate to Crossmember Mounting-Quantity 4, (NOT SERVICED)
-9	06101340	3	5						U-NUT, M10-1.50, Skid Plate to Front of Frame, Mounting
-10	06101340	3							SCREW AND WASHER, Hex Head, M10x1.5x40, Skid Plate to Front of Frame Mounting-Quantity 3, (NOT SERVICED)

DAKOTA (AN)

SERIES LINE  
L = Regular Cab 1 = Lt. Duty DODGE 2WD  
L = Club Cab 5 = Lt. Duty DODGE 4WD

BODY  
31 = CLUB CAB 2-DR 6.5 FT BOX  
61 = REG CAB 6.5 FT BOX  
62 = REG CAB 8 FT BOX

ENGINE  
EHC = "Magnum" 3.9L SMPI V6 Engine  
ELF = 5.2L V8 MPI Engine  
EML = 5.9L V8 MPI Engine  
EPE = Engine - 2.5L Power Tech I-4 Cyl.

TRANSMISSION  
DDC = 5-Speed HD Manual Transmission  
DDK = 5-Speed HD Manual Transmission  
DDQ = 5-Speed Manual Transmission  
DGK = 4-Spd. Automatic 42RE Transmission  
DGT = 4-Spd. Automatic 46RE Transmission  
DGW = TRANSMISSION - 4-SPD. AUTOMATIC,44RE  
DD0 = ALL 5 SPEED MANUAL TRANSMISSIONS  
DG0 = TRANSMISSIONS - ALL AUTOMATIC

AR = use ase required - = Non illustrated part

1998 AN

# Group - 3

## Rear Axle

### Group - 3 Rear Axle

Group-Fig. No.

Illustration Title

#### Rear Axle

Axle Assembly,Rear,Corporate 8.25 [DRA] .....	Fig. 3 - 110
Axle Assembly,Rear Corporate 9.25 [DRB] .....	Fig. 3 - 120

#### Differential and Housing

Axle,Rear,with Differential and Housing,Corporate 8.25 [DRA].....	Fig. 3 - 210
Axle,Rear,with Differential and Housing,Corporate 9.25 [DRB].....	Fig. 3 - 220

#### Rear Axle Vent

Vent,Axle.....	Fig. 3 - 310
----------------	--------------

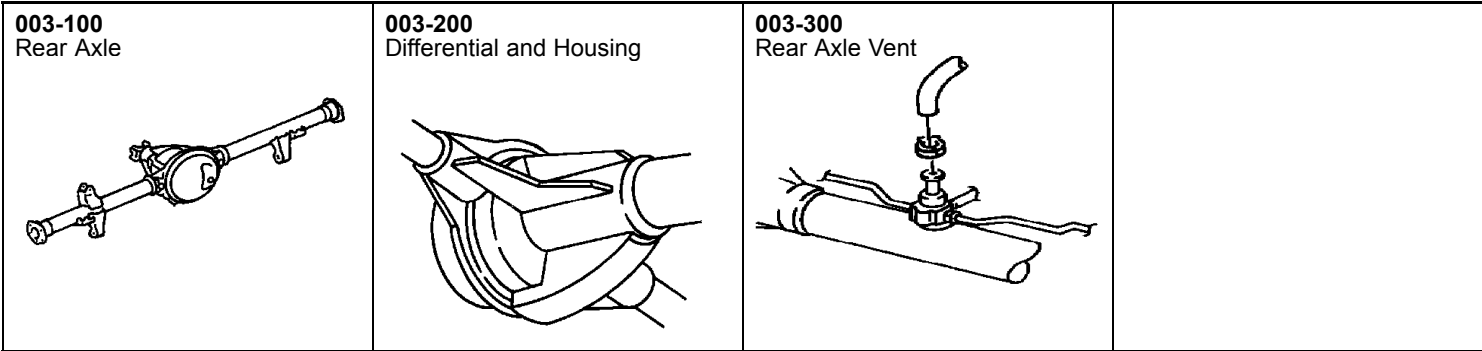

**Axle Assembly,Rear,Corporate 8.25 [DRA]  
Figure 3-110**

ITEM	PART NUMBER	QTY	LINE	SERIES	BODY	ENGINE	TRANS	TRIM	DESCRIPTION
------	-------------	-----	------	--------	------	--------	-------	------	-------------

Note:Sales Codes defined below;  
 DMC = Axle Ratio - 3.21  
 DMD = Axle Ratio - 3.55  
 DMH = Axle Ratio - 3.92  
 DRA = Axle - Rear, Corporate 8.25  
 DSA = Axle - Anti-Spin Differential

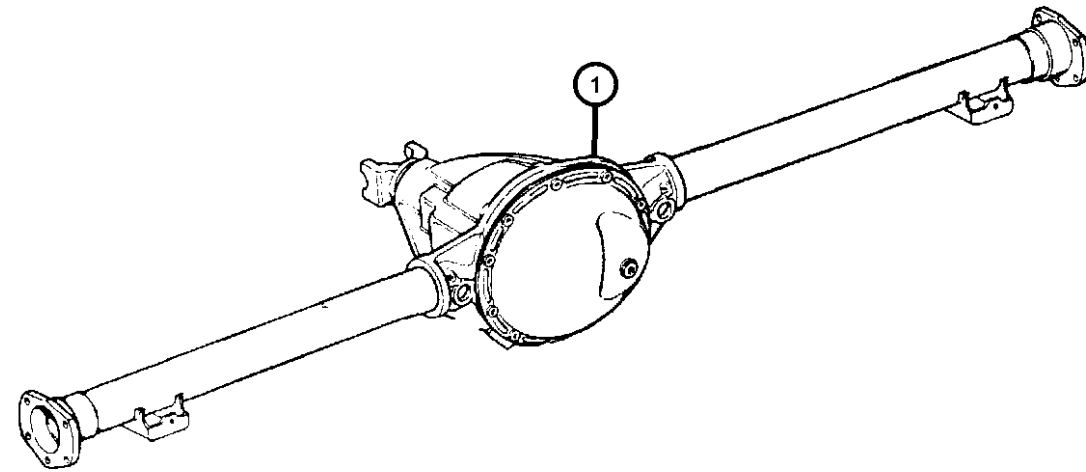

1									AXLE, Service Rear
	04897071AB	1	1						[DMH,-DSA] Tag# 52069633AB, 52069779AB, 52069632AB
	05010320AA								Mopar SAE 75W-90 Synthetic Gear Lube Quart
	68003056								Mopar SAE 75W-90 Synthetic Gear Lube 16 Gallon Keg
	04897073AB	1	1						[DMC,-DSA] Tag# 52069642AB,
	05010320AA								Mopar SAE 75W-90 Synthetic Gear Lube Quart
	68003056								Mopar SAE 75W-90 Synthetic Gear Lube 16 Gallon Keg
	04897076AB	1	5						[DMD,-DSA] Tag# 52069635AB, 52069811AB, 52069636AB, 56029812AB
	05010320AA								Mopar SAE 75W-90 Synthetic Gear Lube Quart
	68003056								Mopar SAE 75W-90 Synthetic Gear Lube 16 Gallon Keg
	04897079AB	1	1						[DMD,+DSA] Tag# 52069647AB, 52069816AB,
	05010320AA								Mopar SAE 75W-90 Synthetic Gear Lube Quart
	68003056								Mopar SAE 75W-90 Synthetic Gear Lube 16 Gallon Keg
	04897083AB	1	5						[DMD,+DSA] Tag# 52069644AB, 52069815AB,
	05010320AA								Mopar SAE 75W-90 Synthetic Gear Lube Quart
	68003056								Mopar SAE 75W-90 Synthetic Gear Lube 16 Gallon Keg

**DAKOTA (AN)**

SERIES      LINE  
 L = Regular Cab    1 = Lt. Duty DODGE 2WD  
 L = Club Cab        5 = Lt. Duty DODGE 4WD

BODY  
 31 = CLUB CAB 2-DR 6.5 FT BOX  
 61 = REG CAB 6.5 FT BOX  
 62 = REG CAB 8 FT BOX

ENGINE  
 EHC = "Magnum" 3.9L SMPI V6 Engine  
 ELF = 5.2L V8 MPI Engine  
 EML = 5.9L V8 MPI Engine  
 EPE = Engine - 2.5L Power Tech I-4 Cyl.

TRANSMISSION  
 DDC = 5-Speed HD Manual Transmission  
 DDK = 5-Speed HD Manual Transmission  
 DDQ = 5-Speed Manual Transmission  
 DGK = 4-Spd. Automatic 42RE Transmission  
 DGT = 4-Spd. Automatic 46RE Transmission  
 DGW = TRANSMISSION - 4-SPD. AUTOMATIC,44RE  
 DD0 = ALL 5 SPEED MANUAL TRANSMISSIONS  
 DG0 = TRANSMISSIONS - ALL AUTOMATIC

AR = use ase required    - = Non illustrated part

1998 AN

ITEM	PART NUMBER	QTY	LINE	SERIES	BODY	ENGINE	TRANS	TRIM	DESCRIPTION
	04897092AB	1	1						[DMD,-DSA] Tag# 52069637AB,52069638AB, 52069814AB
	05010320AA								Mopar SAE 75W-90 Synthetic Gear Lube Quart
	68003056								Mopar SAE 75W-90 Synthetic Gear Lube 16 Gallon Keg
	04897124AB	1	5						[DMH,-DSA] Tag# 52069631AB, 52069777AB
	05010320AA								Mopar SAE 75W-90 Synthetic Gear Lube Quart
	68003056								Mopar SAE 75W-90 Synthetic Gear Lube 16 Gallon Keg
	04897127AB	1	1						[DMH,+DSA] Tag# 52069651AB, 52069652AB,
	05010320AA								Mopar SAE 75W-90 Synthetic Gear Lube Quart
	68003056								Mopar SAE 75W-90 Synthetic Gear Lube 16 Gallon Keg
	04897132AB	1	5						[DMH,+DSA]Tag# 52069649AB, 52069650AB,
	05010320AA								Mopar SAE 75W-90 Synthetic Gear Lube Quart
	68003056								Mopar SAE 75W-90 Synthetic Gear Lube 16 Gallon Keg

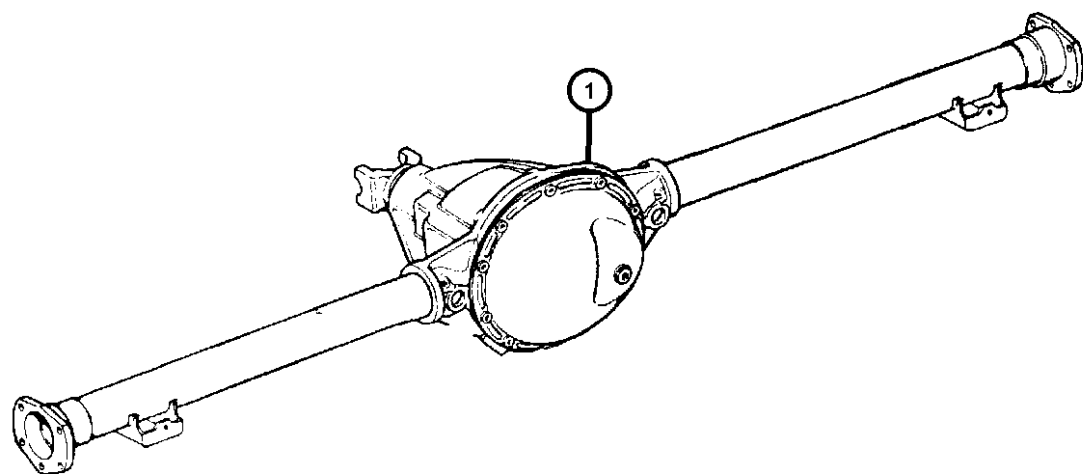

**DAKOTA (AN)**

SERIES      LINE  
 L = Regular Cab    1 = Lt. Duty DODGE 2WD  
 L = Club Cab        5 = Lt. Duty DODGE 4WD

BODY  
 31 = CLUB CAB 2-DR 6.5 FT BOX  
 61 = REG CAB 6.5 FT BOX  
 62 = REG CAB 8 FT BOX

ENGINE  
 EHC = "Magnum" 3.9L SMPI V6 Engine  
 ELF = 5.2L V8 MPI Engine  
 EML = 5.9L V8 MPI Engine  
 EPE = Engine - 2.5L Power Tech I-4 Cyl.

TRANSMISSION  
 DDC = 5-Speed HD Manual Transmission  
 DDK = 5-Speed HD Manual Transmission  
 DDQ = 5-Speed Manual Transmission  
 DGK = 4-Spd. Automatic 42RE Transmission  
 DGT = 4-Spd. Automatic 46RE Transmission  
 DGW = TRANSMISSION - 4-SPD. AUTOMATIC,44RE  
 DD0 = ALL 5 SPEED MANUAL TRANSMISSIONS  
 DG0 = TRANSMISSIONS - ALL AUTOMATIC