

VIN PLATE DECODING INFORMATION

1	2	3	4	5	6	7	8	9	10	11	12 thru 17
Country	Make	Vehicle Type	Other	Line	Series	Body Style	Engine	Check Digit	Model Year	Assy. Plant	Sequence No.

The following table interprets the VIN Plate position shown above.

Position	Interpretation	Codes = Description
1	Country of Origin	1 = Built in U.S. by DaimlerChrysler Corporation 2 = Built in Canada by DaimlerChrysler Canada Inc
2	Assembler	B = Dodge C = Chrysler D = Dodge
3	Vehicle Type	3 = Passenger Car
4	GVWR & Pass. Safety	H = Restraint System Active Driver & Passenger Air Bag
5	Vehicle Line	C = Chrysler LHS D = Chrysler Concorde D = Dodge Intrepid (USA) E = Chrysler 300M H = Chrysler Intrepid (Canada)
6	Series	4 = High Line (H) 5 = Premium Line (P) 6 = Sport Line (S)
7	Body Style	6 = 4 Door Sedan
8	Engine	G = 3.5L 6 cyl. 24V (EGG) J = 3.2L 6 cyl. 24V SOHC (EGW) R = 2.7L 6 cyl. DOHC FF (EER)
9	Check Digit	0 = Check Digit 0 = Check Digit
10	Model Year	W = 1998 X = 1999
11	Assembly Plant	H = Brampton Assembly
12 thru 17	Vehicle Build Sequence	Model Year Assembly Sequence

Group - 2

Front Suspension & Drive

Group - 2 Front Suspension & Drive

Group-Fig. No.



Illustration Title

Front Suspension

Suspension, Front..... Fig. 2 - 110

Front Axle Drive Shafts

Shaft, Front Drive Fig. 2 - 210

<p>002-100 Front Suspension</p> 	<p>002-200 Front Axle Drive Shafts</p> 		
--	---	--	--

Suspension, Front
Figure 2-110

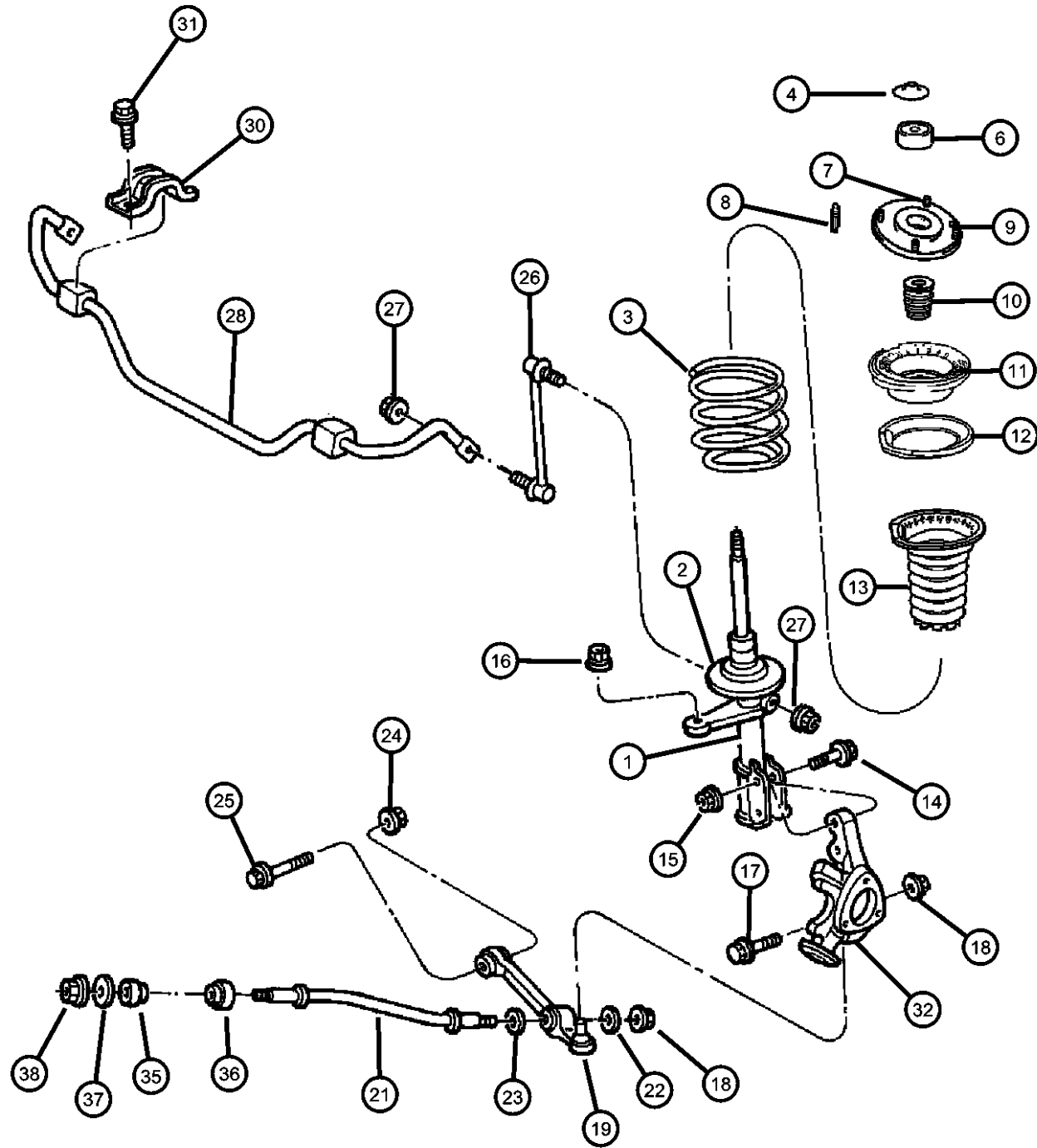

ITEM	PART NUMBER	QTY	LINE	SERIES	BODY	ENGINE	TRANS	TRIM	DESCRIPTION
------	-------------	-----	------	--------	------	--------	-------	------	-------------

Sales Codes:
 BR3=ANTI-LOCK 4-WHEEL DISC
 BRB= POWER FRONT DISC/REAR DRUM
 BRE= 4-WHEEL DISC
 BRG=ANTI-LOCK 4-WHEEL-DISC, 15"
 SDC = Firm Feel Suspension
 SDD = Performance Tuned Suspension
 SDG = Luxury Tuned Suspension
 ZAC Thru ZRF= Spring Group Types Found on Individual Vehical Sales Listing.

1	04782012AB	1							DAMPER, Strut [SDC], Right
	0SG81667								Mopar V-Line Alternative Part
	04782013AB	1							[SDC], Left
	0SG81668								Mopar V-Line Alternative Part
	04782110AD	1							[SDD], Right
	0SG81667								Mopar V-Line Alternative Part
	04782111AC	1							[SDD], Left
	0SG81668								Mopar V-Line Alternative Part
	04895182AB	1							[SDG], Right
	0SG81667								Mopar V-Line Alternative Part
	04895183AB	1							[SDG], Left
	0SG81668								Mopar V-Line Alternative Part
2	04782228AA	1							ISOLATOR, Front Suspension SpringLower
3									SPRING, Front Coil
	04782083	1							[SDC], [ZAC-ZNC] [SDD], [ZBC-ZPC]
	04782084AB	1							[SDC], [ZND-ZAD] [SDD] [ZBD] [SDG] ZRD-ZCD]
	04782085	1							[SDC], [ZAE-ZNE] [SDD], [ZBE-ZPE]
	04782086	1							[SDD], [ZPF-ZBF] [SDG], [ZCF-ZRF]
4	04616748	2							CAP, Strut Mount
-5	06502525	2							NUT, Hex Lock, M14 x 2.00
6	04782238AB	1							CUP, Jounce Bumper
7	06101446	8							NUT AND WASHER, Strut to Tower
8	06101446	8							PIN, Front Strut Alignment, (NOT SERVICED)
9									MOUNT, Strut

CONCORDE,INTREPID,VISION,300M,NEW YORKER,LHS (LH)

SERIES	LINE	BODY	ENGINE	TRANSMISSION
H = HIGHLINE	D = Intrepid	41 = 4 Door Sedan	EER = 2.7L V6 DOHC 24 Valve MPI Engine	DGX = 4-Speed Automatic Transmission
P = PREMIUM	C = LHS, Concorde		EGG = 3.5L High Output V6 24V MPI Engine	DG0 = All Automatic
S = Special	Y = 300 M		EGW = 3.2L V6 SOHC 24 Valve MPI Engine	

AR = use ase required - = Non illustrated part

Suspension, Front
Figure 2-110

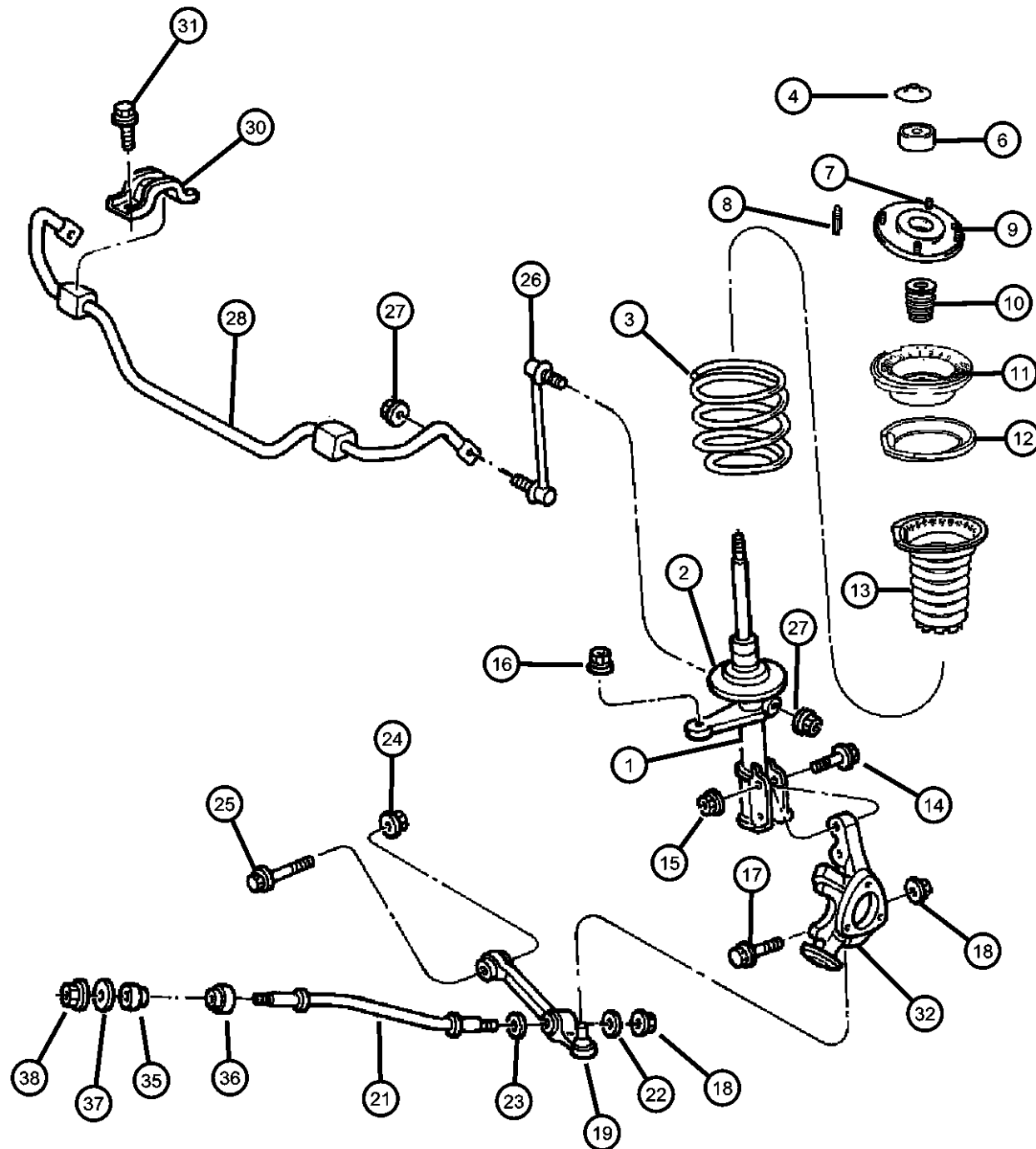

ITEM	PART NUMBER	QTY	LINE	SERIES	BODY	ENGINE	TRANS	TRIM	DESCRIPTION
	04782018AB	1							Right
	04782019AB	1							Left
10									BUMPER, Jounce
	04782017	1							[SDC]
	04782112	1							[SDD-SDG]
11	04782016	1							SEAT AND BEARING, Suspension Strut
12	04782233AA	1							ISOLATOR, Front Suspension SpringUpper
13	04782235AA	1							SHIELD, Suspension, Dust
14	06502630	4							BOLT, Hex Head, M16x2.00x75, Strut to Knuckle
15	06504707	4							NUT, w/Washer Strut to Knuckle
16	06502544	2							NUT, Hex Lock, M10x1.25, Tie Rod to Strut
17	06502411	2							SCREW, Hex Head, M12-1.75x55, Knuckle Lower Control Arm
18	06502526	2							NUT, Hex Locking, M12x1.75, Knuckle Lower Control Arm
19									ARM, Control
	04782120	1							Right
	04782121	1							Left
-20	06504707	4							NUT, Hex Flg Lock LCA Tension Strut M16x2.00
21	04782060	2							STRUT, Front Suspension, Tension
22	04616365	2							RETAINER, Strut to Bushing, Tension Strut
23	06502420	2							WASHER, Flat, 21mm ID, Tension Strut or Bushing
24	06502502	2							NUT, Hex Flange Lock, M14x2, Arm Strut Damper and LCAS Pivot Bolt
25	06504989AA	2							SCREW AND WASHER, Hex Head, M14-2x95, LCA Pivot M14x2.00x95.00
26									LINK, Sway Eliminator
	04782232AA	1							Upto 7-19-98
	04782254AB	1							After 7-19-98
27	06502724	2							NUT, Hex Flange, M12x1.75, Sway Bar Link M12x1.75
28	04772633AB	1							BAR, Front Sway, Sway Eliminating

CONCORDE,INTREPID,VISION,300M,NEW YORKER,LHS (LH)

SERIES LINE BODY
H = HIGHLINE D = Intrepid 41 = 4 Door Sedan
P = PREMIUM C = LHS, Concorde
S = Special Y = 300 M

ENGINE TRANSMISSION
EER = 2.7L V6 DOHC 24 Valve MPI Engine DGX = 4-Speed Automatic Transmission
EGG = 3.5L High Output V6 24V MPI Engine DG0 = All Automatic
EGW = 3.2L V6 SOHC 24 Valve MPI Engine

AR = use ase required - = Non illustrated part

1998 LH

Suspension, Front
Figure 2-110

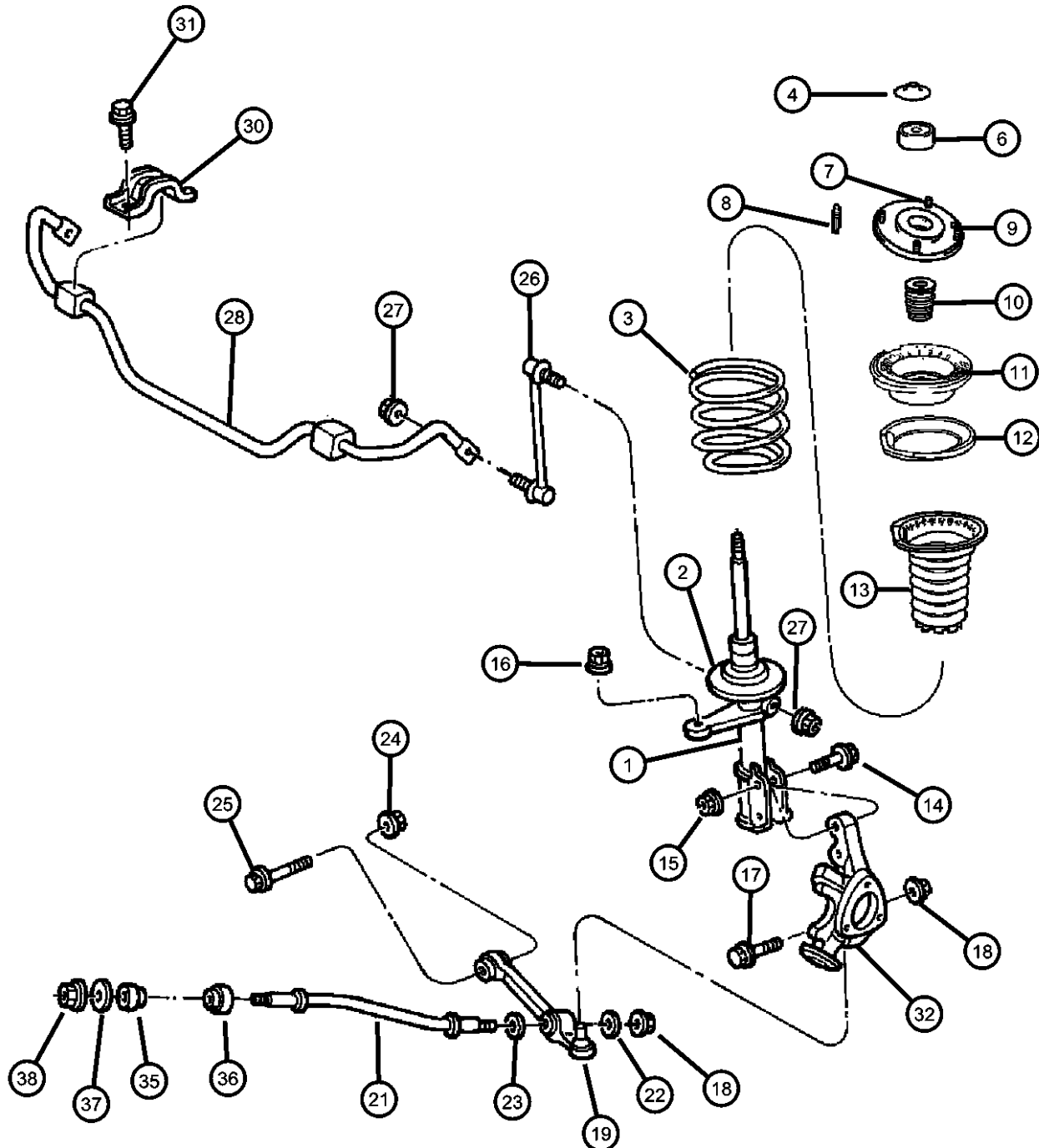

ITEM	PART NUMBER	QTY	LINE	SERIES	BODY	ENGINE	TRANS	TRIM	DESCRIPTION
-29									ISOLATOR
	04772541	2							[SDG], Front Sway Bar
	04772543	2							[SDC-SDD], Front Sway Bar
30	04772487	2							CLAMP, Stabilizer Bar, Shaft Mounting
31	06101504	4							SCREW AND WASHER, Hex Head, M10x1.5x50
32									KNUCKLE, Front
	04782004AB	1							[BRE-BRG], Right
	04782005AB	1							[BRE-BRG], Left
	04782124AB	1			D				[BR3], Right
		1			C				[BR3], Right
	04782125AB	1			D				[BR3], Left
		1			C				[BR3], Left
-33	04782224AB	1							SHIELD, Brake, Knuckle to LCA
-34	06504693	2							SCREW, Tapping, Tap Heatshield Att M6x1.00x12.00
35	04616380	2							BUSHING, Lower Control Arm, LCA Strut to Cradle Front
36	04616383	2							BUSHING, Lower Control Arm, LCA Strut to Cradle Rear
37	06502409	2							WASHER, Flat, 16mm ID, Tension Strut to Cradle Bush
38	06504707	4							NUT
-39	06502525	2							NUT, Hex Lock, M14 x 2.00, Hex Lock Lat Link to Knuckle

CONCORDE,INTREPID,VISION,300M,NEW YORKER,LHS (LH)

SERIES LINE BODY
H = HIGHLINE D = Intrepid 41 = 4 Door Sedan
P = PREMIUM C = LHS, Concorde
S = Special Y = 300 M

ENGINE TRANSMISSION
EER = 2.7L V6 DOHC 24 Valve MPI Engine DGX = 4-Speed Automatic Transmission
EGG = 3.5L High Output V6 24V MPI Engine DG0 = All Automatic
EGW = 3.2L V6 SOHC 24 Valve MPI Engine

AR = use ase required - = Non illustrated part

1998 LH

**Shaft, Front Drive
Figure 2-210**

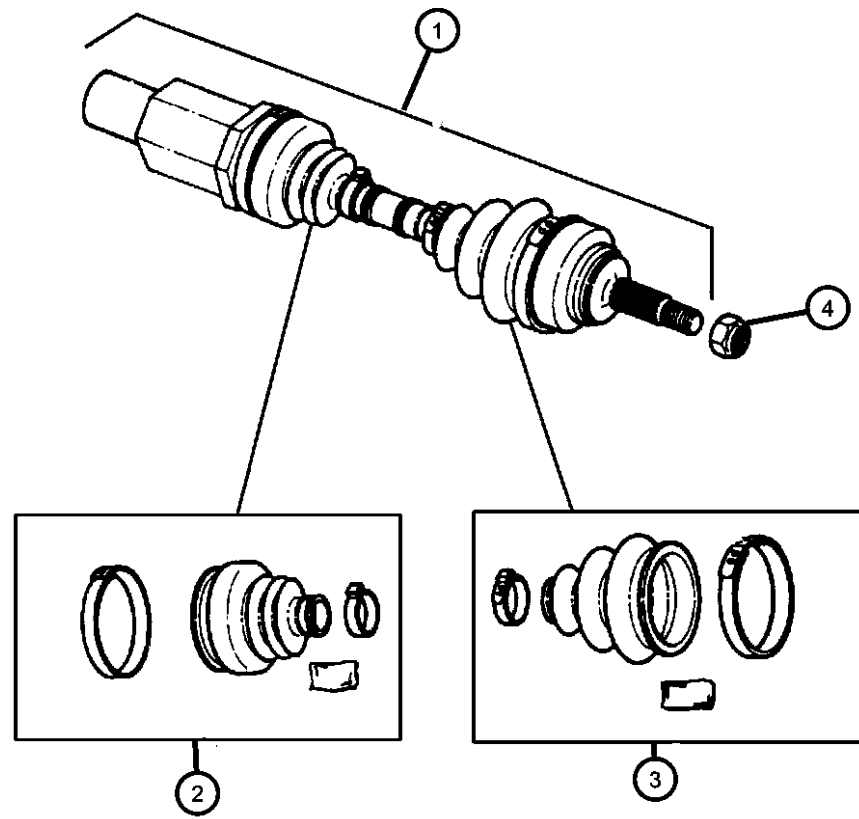

ITEM	PART NUMBER	QTY	LINE	SERIES	BODY	ENGINE	TRANS	TRIM	DESCRIPTION
Sales Code: DGX= 4-SPEED AUTOMATIC EER= 2.7L V6 DOHC 24 Valve EGG= 3.5L High Output V6 EGW= 3.2L V6 SOHC 24 Valve									
1	04882517	1							SHAFT, Front Drive with ABS, Left
	R2073753								Mopar Remanufactured Part with ABS, Right
	04882518	1							Mopar Remanufactured Part without ABS, Left
	R2073763								Mopar Remanufactured Part without ABS, Right
2	04728261	2							BOOT KIT, Half Shaft, Inner
3	04863722	2							BOOT KIT, Half Shaft, Outer
4	06502541	2							NUT, Hex Flange Lock, M27x2, [34mm] Driveshaft Retaining
-5	06502363	2				EGG, EGW	DGX		O RING, CV Joint Halfshaft Inner CV Joint Sealing I.D. 25.32 C/S 2.69
		2				EER	DGX		
-6	04593012	2				EGG, EGW	DGX		CIRCLIP, Half Shaft
		2				EER	DGX		

CONCORDE,INTREPID,VISION,300M,NEW YORKER,LHS (LH)

SERIES	LINE	BODY
H = HIGHLINE	D = Intrepid	41 = 4 Door Sedan
P = PREMIUM	C = LHS, Concorde	
S = Special	Y = 300 M	

ENGINE	TRANSMISSION
EER = 2.7L V6 DOHC 24 Valve MPI Engine	DGX = 4-Speed Automatic Transmission
EGG = 3.5L High Output V6 24V MPI Engine	DG0 = All Automatic
EGW = 3.2L V6 SOHC 24 Valve MPI Engine	

AR = use ase required - = Non illustrated part

1998 LH

Group - 4

Parking Brake

Group - 4 Parking Brake

Group-Fig. No.

Illustration Title

Parking Brake Lever and Cables

Lever Assembly And Cables Parking Brake Fig. 4 - 110

004-100
Parking Brake Lever and Cables

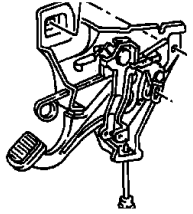

**Lever Assembly And Cables Parking Brake
Figure 4-110**

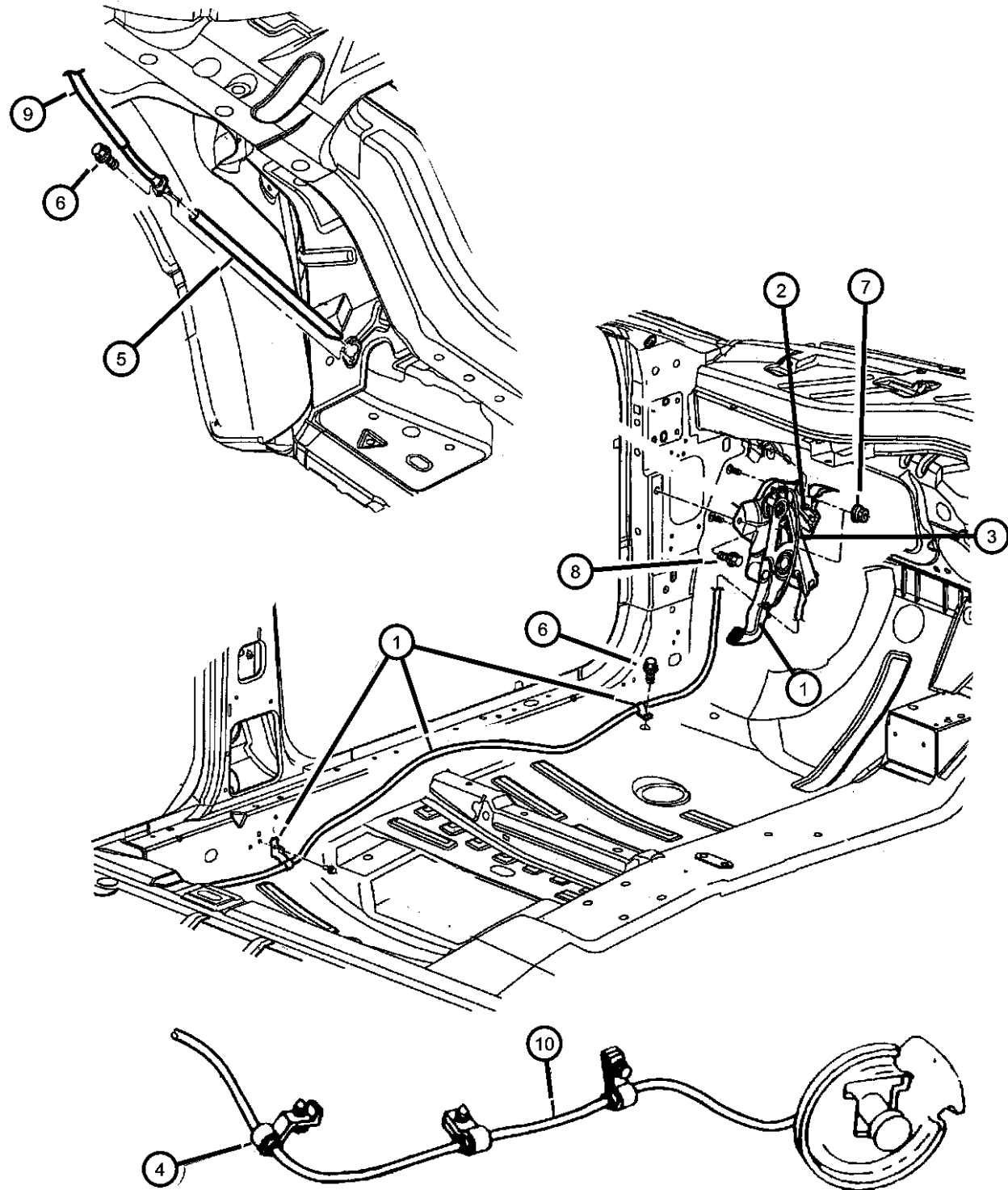

ITEM	PART NUMBER	QTY	LINE	SERIES	BODY	ENGINE	TRANS	TRIM	DESCRIPTION
1	04779088	1							LEVER, Park Brake, With Cable
2	04221463	1							SWITCH, Parking Brake
3	05135211AA	1							CABLE, Parking Brake Release
4	05135211AA	1							CLIP, Rear Parking Brake Cables (Service in Item 8), (NOT SERVICED)
5	04779086	1							TUBE, Brake, Cable
6	06504828AA	1							SCREW, Tap Hex Flg Hd P/Brake Cable Front, Rear, Intermediate M6.3x1.81x19.00
7	06101445	1							NUT AND WASHER, Hex Nut-Coned Washer, M8 x 1.25, P/Brake Lever Attch
8	06101795	1							SCREW, Tapping, M8x1.25x30, P/Brake Mech Mount
9	04779071	1							CABLE, Parking Brake, Intermediate
10	04779076	2							CABLE, Parking Brake, Rear
-11									SPACER, Parking Brake
	04779082	1							Right
	04779083	1							Left
-12	02201467	2							CLIP, Parking Brake Cable, Rear
-13	04779038	1							EQUALIZER, Parking Brake Cable, Tensioner P/Brake Rear
-14	04580640AB	1							BRACKET, Parking Brake Cable, Reaction
-15									HANDLE, Parking Brake
	0QN42HD5	1			D				Medium Quartz
		1			C				Medium Quartz
	0QN42LAZ	1			D				Agate
		1			C				Agate
	0QN42MF1	1			C				Light Neutral
	0QN42RK5	1			D				Camel Tan/Agate
		1			C				Camel Tan/Agate
-16		1							PAD, Parking Brake Lever, Service in Item 1, (NOT REQUIRED),
-17		1							BRACKET, Parking Brake, Service in Cover Assy, Inst Panel Group 8, (NOT SERVICED)
-18									CLIP, Push, .164-7.5

CONCORDE,INTREPID,VISION,300M,NEW YORKER,LHS (LH)

SERIES	LINE	BODY
H = HIGHLINE	D = Intrepid	41 = 4 Door Sedan
P = PREMIUM	C = LHS, Concorde	
S = Special	Y = 300 M	

ENGINE	TRANSMISSION
EER = 2.7L V6 DOHC 24 Valve MPI Engine	DGX = 4-Speed Automatic Transmission
EGG = 3.5L High Output V6 24V MPI Engine	DG0 = All Automatic
EGW = 3.2L V6 SOHC 24 Valve MPI Engine	

AR = use ase required - = Non illustrated part

1998 LH

**Lever Assembly And Cables Parking Brake
Figure 4-110**

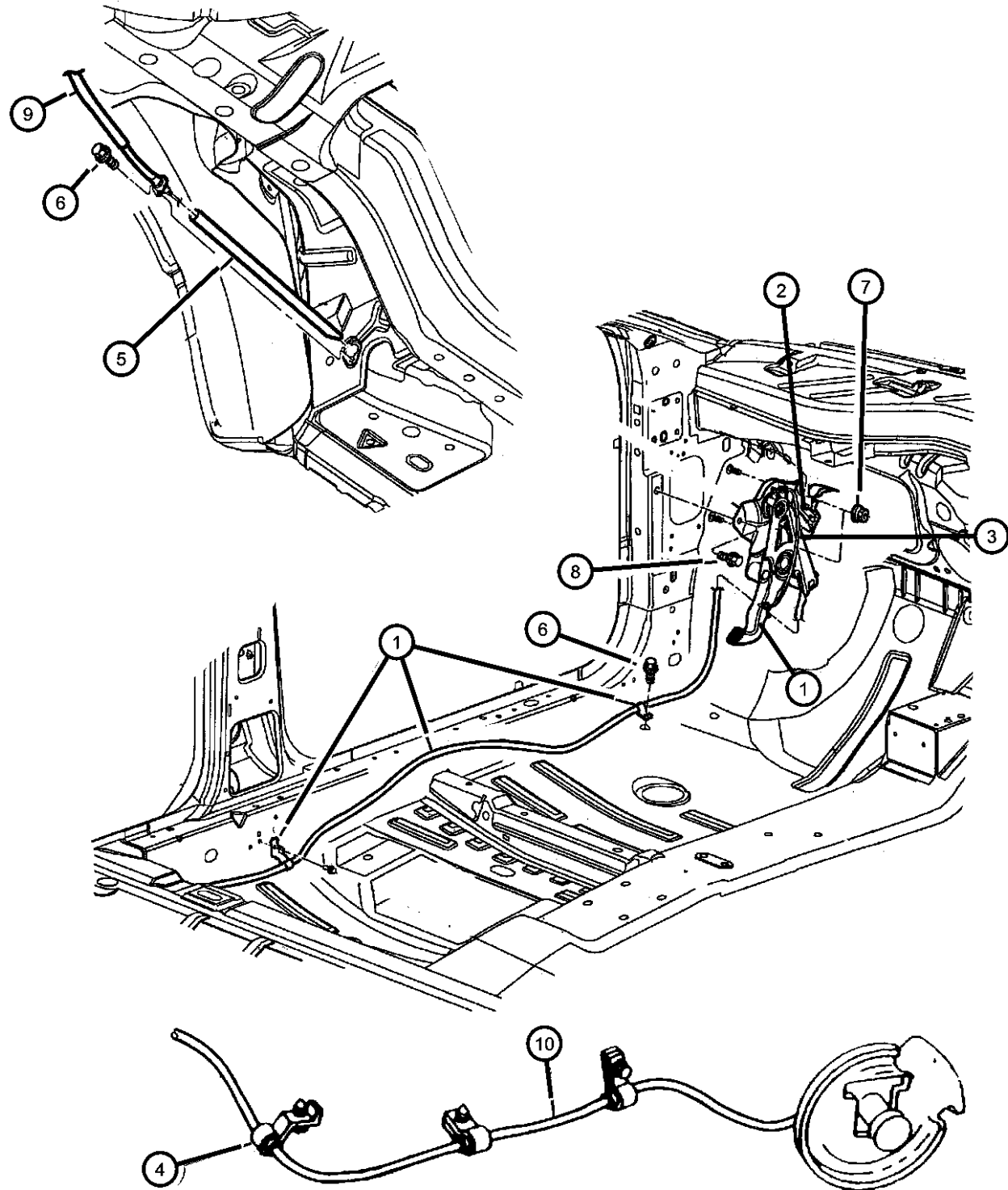

ITEM	PART NUMBER	QTY	LINE	SERIES	BODY	ENGINE	TRANS	TRIM	DESCRIPTION
	06034833	2	D						P/Brake Mount
		2	C						P/Brake Mount
		2	X, Y						P/Brake Mount
-19	06034743	5							SCREW, Hex Flange Head Tapping, .164-15x.75, P/Brake Handle to Cvr

CONCORDE,INTREPID,VISION,300M,NEW YORKER,LHS (LH)

SERIES	LINE	BODY
H = HIGHLINE	D = Intrepid	41 = 4 Door Sedan
P = PREMIUM	C = LHS, Concorde	
S = Special	Y = 300 M	

ENGINE	TRANSMISSION
EER = 2.7L V6 DOHC 24 Valve MPI Engine	DGX = 4-Speed Automatic Transmission
EGG = 3.5L High Output V6 24V MPI Engine	DG0 = All Automatic
EGW = 3.2L V6 SOHC 24 Valve MPI Engine	

AR = use ase required - = Non illustrated part

1998 LH

Group - 5

Service Brakes

Group - 5 Service Brakes

Group-Fig. No.

Illustration Title

Front Brakes

Brakes, Front Fig. 5 - 110

Rear Brakes

Brakes, Rear Disc Fig. 5 - 210

Power Brake Booster

Booster, Power Brake Fig. 5 - 310

Brake Master Cylinder

Hydraulic Control Unit Anti-lock Brakes Fig. 5 - 410

Master Cylinder, Brake Fig. 5 - 420



Brake Lines and Hoses

Lines And Hoses, Front Brakes Fig. 5 - 510

Lines and Hoses, Rear Brakes Fig. 5 - 520

Brake Pedals

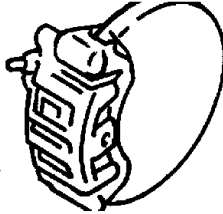
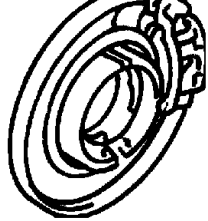
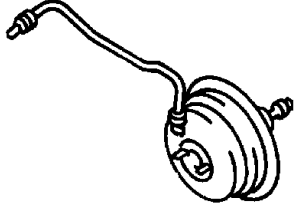
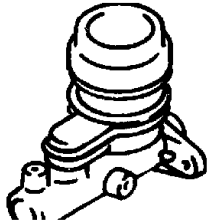
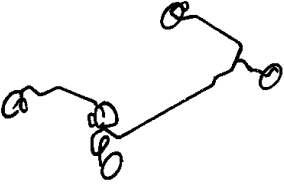
Pedal, Brake Fig. 5 - 610

<p>005-100 Front Brakes</p> 	<p>005-200 Rear Brakes</p> 	<p>005-300 Power Brake Booster</p> 	<p>005-400 Brake Master Cylinder</p> 
<p>005-500 Brake Lines and Hoses</p> 	<p>005-600 Brake Pedals</p> 		

**Brakes, Front
Figure 5-110**

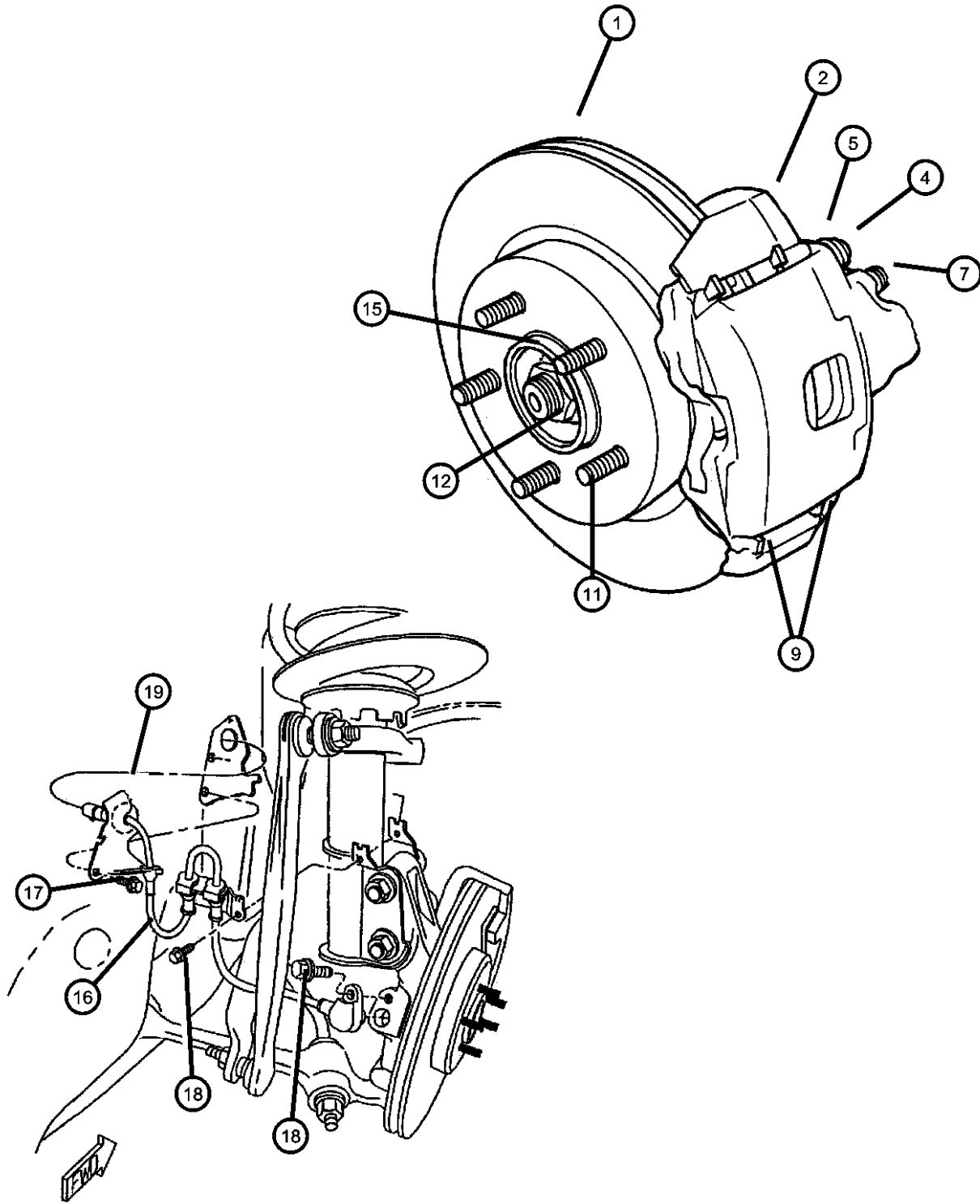

ITEM	PART NUMBER	QTY	LINE	SERIES	BODY	ENGINE	TRANS	TRIM	DESCRIPTION
SALES CODE: BRE=4-WHEEL DISC BRB= POWER FRONT DISC/REAR DRUM BRG= ANTI-LOCK 4-WHEEL-DISC, 15" BR3= ANTI-LOCK 4-WHEEL DISC BR4= ANTI-LOCK 4-WHEEL DISC, PERF WCS=16 X 7.0 BLACK									
1									ROTOR, Brake
	04779020	1							[BRB, BRG, BRE]
	04779044	1	D						[BR3] Wth [WCS]
	V5019101								Mopar V-Line Alternative Brake Rotors
		1	C						[BR3] Wth [WCS]
	V5019101								Mopar V-Line Alternative Brake Rotors
		1	C						[BR3] Wth [WCS]
	V5019101								Mopar V-Line Alternative Brake Rotors
		1	X						[BR3] Wth [WCS]
	V5019101								Mopar V-Line Alternative Brake Rotors
	04779101AA	1							[BR3]
	V5019101								Mopar V-Line Alternative Brake Rotors
	04779133AA	1							[BR4]
2									CALIPER, Disc Brake
	05010032AA	1							Right
	05010033AA	1							Left
-3	04728121	1							PISTON PACKAGE, Disc Brake, [34M]
4	06502527	4							BOLT, Hex Flange Head, M8-1.25x68.50, Front Caliper Mounting
5	04383471	1							BUSHING, Disc Brake Caliper
-6	04423573	1							SLEEVE, Disc Brake Caliper
7	03780788	1							BLEEDER SCREW, Brake
-8	04238717	1							CAP, Bleeder
9									PAD KIT, Front Disc Brake
	05010034AA	1							w/o European
	V1013034AB								Mopar V-Line Alternative Part

CONCORDE,INTREPID,VISION,300M,NEW YORKER,LHS (LH)

SERIES LINE BODY
H = HIGHLINE D = Intrepid 41 = 4 Door Sedan
P = PREMIUM C = LHS, Concorde
S = Special Y = 300 M

ENGINE TRANSMISSION
EER = 2.7L V6 DOHC 24 Valve MPI Engine DGX = 4-Speed Automatic Transmission
EGG = 3.5L High Output V6 24V MPI Engine DG0 = All Automatic
EGW = 3.2L V6 SOHC 24 Valve MPI Engine

AR = use ase required - = Non illustrated part

1998 LH

**Brakes, Front
Figure 5-110**

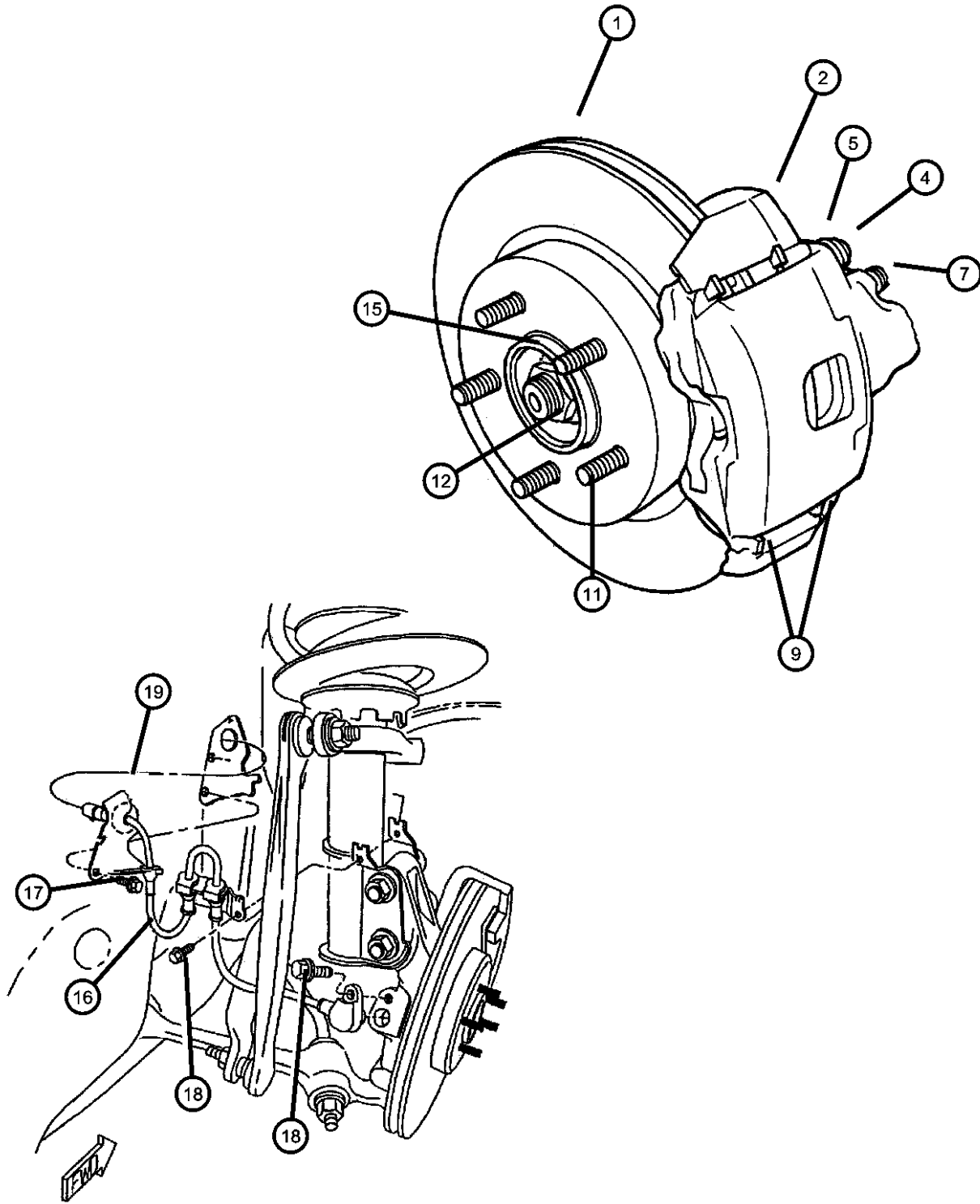

ITEM	PART NUMBER	QTY	LINE	SERIES	BODY	ENGINE	TRANS	TRIM	DESCRIPTION
	BHKH5654								Mopar V-Line Alternative Part Disc Hardware
	BHKH5066								Mopar V-Line Alternative Part Caliper Bolts
	VCLH9801								Make It Ceramic Brake Kit
	V3013034								Mopar V-Line Alternative Part Ceramic
	VLH13034								Make It New Brake Kits
	05011743AA	1	C						w/European
	BHKH5654								Mopar V-Line Alternative Part Disc Hardware
	BHKH5066								Mopar V-Line Alternative Part Caliper Bolts
-10	04779055	2							CLIP, Brake, [Is Required when Replacing Pad Package for 15 or 16Inch Brakes]
11	06503007	5							STUD, Hub, With new style Hub use Stud P/N 6505519AA
12	06502541	2							NUT, Hex Flange Lock, M27x2, Hub and Bearing to Spindle
-13	04616211	2							LOCK, Hub And Bearing
-14	06504254	2							PIN, Cotter, Hub and Bearing to Spindle M5x32.00 ***
15	06502884	2							WASHER, Rear Hub, Hub and Bearing to Spindle [Flat]
16									SENSOR, Anti-Lock Brakes
	04779050	1							with ABS, Right
	04779051	1							with ABS, Left
17	04779051	1							SCREW, F/Whl Sensor L Bracket Att (M6.3x1.81x20.00), (NOT SERVICED),
18	06101682	2							BOLT AND CONED WASHER, Hex Head, M6x1.0x20, ABS Sensor
19	06101682	2							GROMMET, ABS Sensor (Service in Item 10), (NOT SERVICED)
-20	06502410	3							BOLT, Hub, And Bearing to Knuckle (M12x1.75-53)
-21	06504055	2							SCREW, Hex Head, M6x1x16, ABS Sensor Bracket to Strut (M6x1.0x16.00)
-22	04593003AB	1							HUB AND BEARING, Brake

CONCORDE,INTREPID,VISION,300M,NEW YORKER,LHS (LH)

SERIES LINE BODY
H = HIGHLINE D = Intrepid 41 = 4 Door Sedan
P = PREMIUM C = LHS, Concorde
S = Special Y = 300 M

ENGINE TRANSMISSION
EER = 2.7L V6 DOHC 24 Valve MPI Engine DGX = 4-Speed Automatic Transmission
EGG = 3.5L High Output V6 24V MPI Engine DG0 = All Automatic
EGW = 3.2L V6 SOHC 24 Valve MPI Engine

AR = use ase required - = Non illustrated part

1998 LH

Brakes, Rear Disc
Figure 5-210

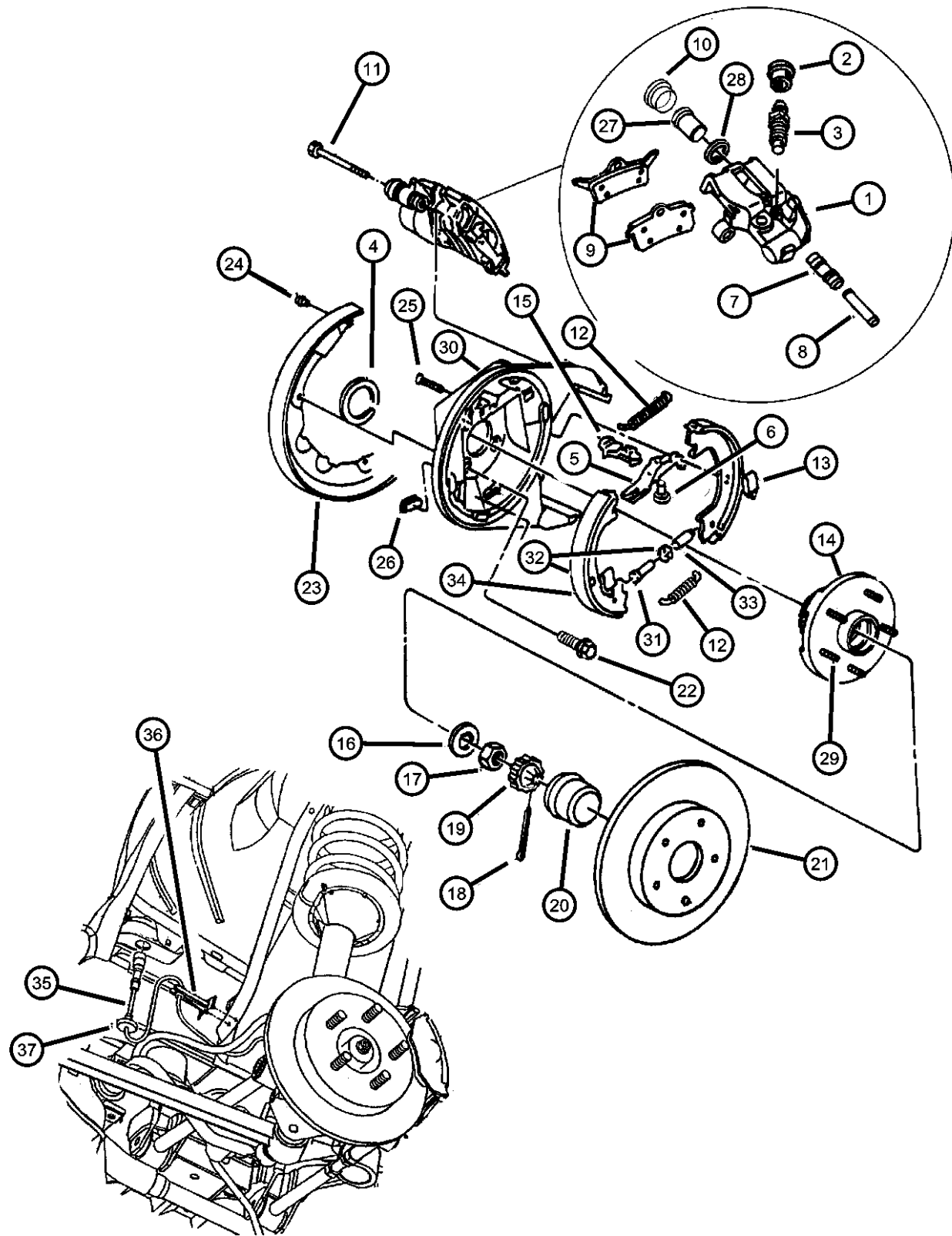

ITEM	PART NUMBER	QTY	LINE	SERIES	BODY	ENGINE	TRANS	TRIM	DESCRIPTION
------	-------------	-----	------	--------	------	--------	-------	------	-------------

NOTE:Sales codes
 [ABB]=EUROPEAN EQUIPMENT GROUP
 [SDC]=SUSPENSION - TOURING
 [SDD]=SUSPENSION - PERFORMANCE
 [SDG]=SUSPENSION - 4-WHL INDEP. TOURING
 [WCF]=WHEELS - 15 X 6.0 BLACK
 [WCS]=WHEELS - 16 X 7.0 BLACK

1									CALIPER, Disc Brake
	05011746AA	1							Right
	05011747AA	1							Left
2	04238717	1							CAP, Bleeder
3	03780788	1							BLEEDER SCREW, Brake
4	04238853	2							SEAL, Brake Support
5	04238853	2							LINK, Brake, Parking Brake [Serv. in Item #15], (NOT SERVICED)
6	04238853	2							PIN, Parking Brake Lever to Link [Serv. in Item #15], (NOT SERVICED)
7	04383471	1							BUSHING, Disc Brake Caliper
8	04423573	1							SLEEVE, Disc Brake Caliper
9									PAD KIT, Rear Disc Brake
	05011631AA	1							[SDD], [ABB]
	BHKH5593								Mopar V-Line Alternative Part Disc Hardware
	BHKH5066								Mopar V-Line Alternative Part Caliper Bolts
	V2013631AB								Mopar V-Line Alternative Part
	05011762AA	1							[SDC]
	VRLH3762AB								Mopar Make it New Rear
	V2013762AC								Mopar V-Line Alternative Part
	BHKH5593								Mopar V-Line Alternative Part Disc Hardware
	BHKH5066								Mopar V-Line Alternative Part Caliper Bolts
		1	X, Y						[SDD], [BR3]
	VRLH3762AB								Mopar Make it New Rear
	V2013762AC								Mopar V-Line Alternative Part
	BHKH5593								Mopar V-Line Alternative Part Disc Hardware
	BHKH5066								Mopar V-Line Alternative Part Caliper Bolts

CONCORDE,INTREPID,VISION,300M,NEW YORKER,LHS (LH)

SERIES	LINE	BODY
H = HIGHLINE	D = Intrepid	41 = 4 Door Sedan
P = PREMIUM	C = LHS, Concorde	
S = Special	Y = 300 M	

ENGINE	TRANSMISSION
EER = 2.7L V6 DOHC 24 Valve MPI Engine	DGX = 4-Speed Automatic Transmission
EGG = 3.5L High Output V6 24V MPI Engine	DG0 = All Automatic
EGW = 3.2L V6 SOHC 24 Valve MPI Engine	

AR = use ase required - = Non illustrated part

1998 LH

Brakes, Rear Disc
Figure 5-210

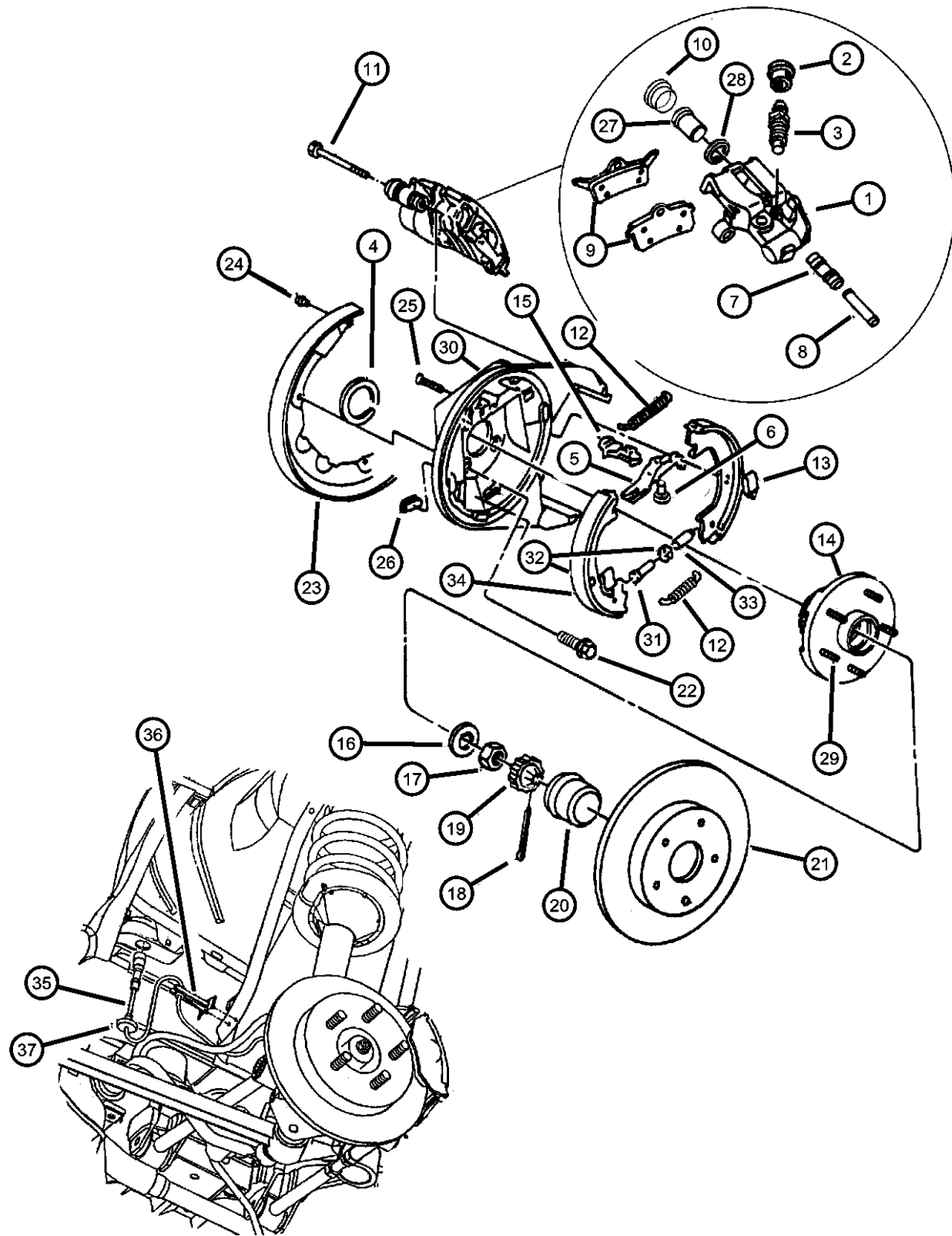

ITEM	PART NUMBER	QTY	LINE	SERIES	BODY	ENGINE	TRANS	TRIM	DESCRIPTION
	VRLH3762AB	1							[SDG]
	V2013762AC								Mopar Make it New Rear
	BHKH5593								Mopar V-Line Alternative Part
	BHKH5066								Mopar V-Line Alternative Part
10		1							Disc Hardware
									Mopar V-Line Alternative Part
									Caliper Bolts
11	06502527	4							BOOT, Brake Piston, Rear Caliper Piston [Service in Item 27], (NOT SERVICED),
12									BOLT, Hex Flange Head, M8-1.25x68.50, Caliper Mounting (M8-1.25x69mm)
	04383541	1							SPRING, Park Brake Shoe Return
	04383542	1							Yellow, Upper
	04383543	1							Blue, Lower
13	04779011	2							CLIP, Brake Shoe Hold Down
14									HUB AND BEARING, Brake
15									LEVER, Park Brake Adjusting
	04882208	1							Right
	04882209	1							Left
16	06502884	2							WASHER, Rear Hub, & Bearing Assembly
17	06502716	2							NUT, Hex, M20-1.5, Hub & Bearing to Spindle
18	06504254	2							PIN, Cotter, Hub & Bearing to Spindle
19	04616211	2							LOCK, Hub And Bearing
20	04616560	2							CAP, Rear Wheel Hub, Rear Bearing (Dust)
21									ROTOR, Brake
	04779018	2							[SDC], with Steel Wheels
	04779111AA	2	D						[SDC], without Steel Wheels
		2	C						[SDC], without Steel Wheels
		2	X						[SDD], without Steel Wheels
22	06101666	8							SCREW AND WASHER, Hex Head, M12x1.75, Adapter to Spindle
23									SHIELD, Brake

CONCORDE,INTREPID,VISION,300M,NEW YORKER,LHS (LH)

SERIES LINE BODY
H = HIGHLINE D = Intrepid 41 = 4 Door Sedan
P = PREMIUM C = LHS, Concorde
S = Special Y = 300 M

ENGINE TRANSMISSION
EER = 2.7L V6 DOHC 24 Valve MPI Engine DGX = 4-Speed Automatic Transmission
EGG = 3.5L High Output V6 24V MPI Engine DG0 = All Automatic
EGW = 3.2L V6 SOHC 24 Valve MPI Engine

AR = use ase required - = Non illustrated part

1998 LH

Brakes, Rear Disc
Figure 5-210

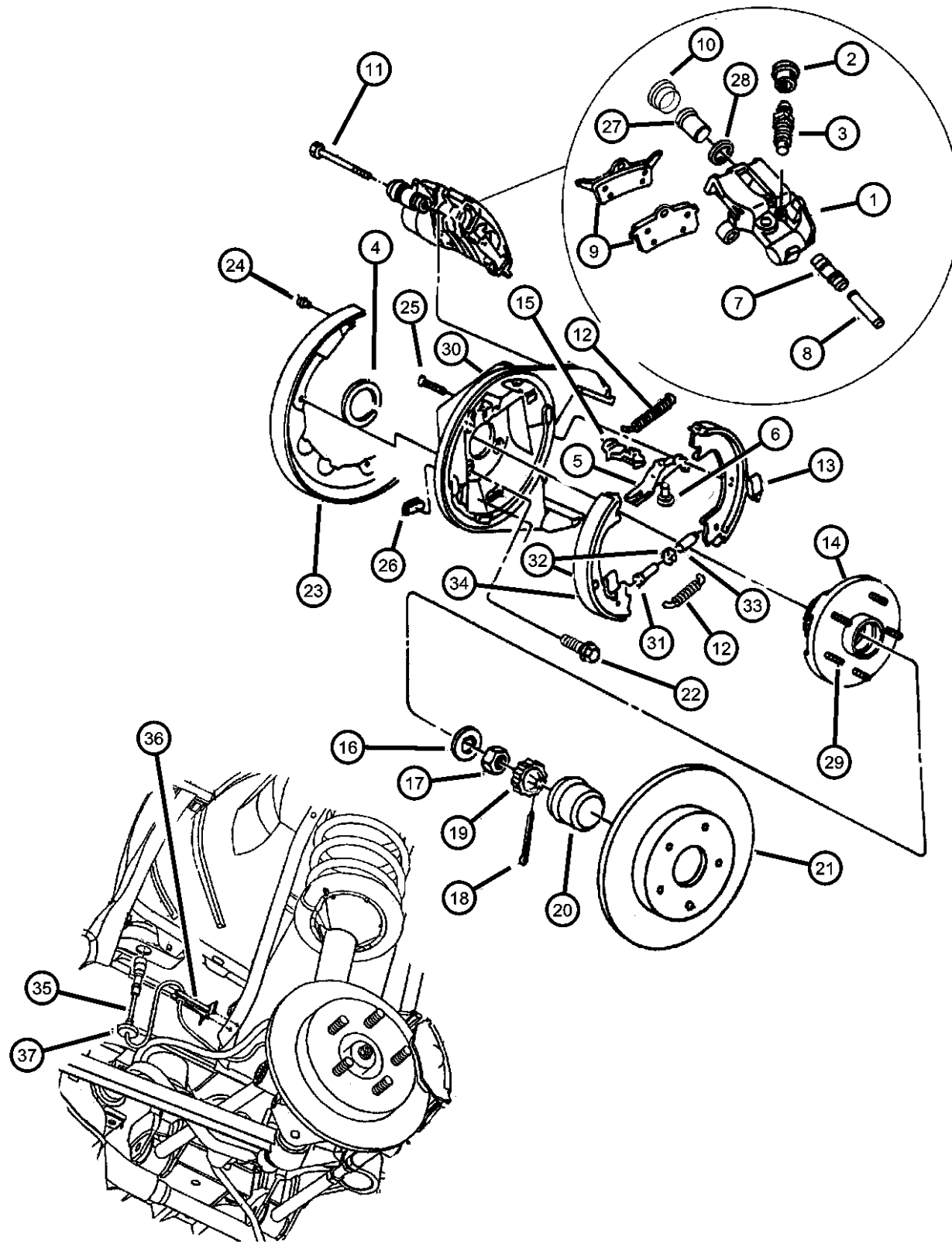

ITEM	PART NUMBER	QTY	LINE	SERIES	BODY	ENGINE	TRANS	TRIM	DESCRIPTION
	04728110	1							Right
	04728111	1							Left
24	04723981	1							SCREW, Rear Brake Dust Shield to Adapter
25	04238733	1							PIN, Brake Shoe Hold Down
26	04238721	1							PLUG, Brake Adjusting Hole
27	05011948AA	1							PISTON PACKAGE, Disc Brake
28	05011948AA	1							SEAL, Caliper Piston, Rear Caliper Piston [Service in Item 27], (NOT SERVICED)
29	06504891AA	10							STUD, Hub
30									ADAPTER, Disc Brake
	04797310	1							Right
	04797311	1							Left
31	04509503	1	C						SCREW, Parking Brake
32	04383539	1							NUT, Parking Brake Adjusting
33	04509504	1							SOCKET, Brake Adjusting Screw
34	04741772	1							SHOE AND LINING, Parking Brake, All Except Europe
	BHKP7300								Mopar Parking Brake Hardware Kit
	BHKP7301								Mopar Parking Brake Hardware Kit
	V2013036								Mopar V-Line Alternative Part
35									SENSOR, Anti-Lock Brakes
	04779052	1							with ABS, Right
	04779053	1							with ABS, Left
36	04779053	1							CLIP, Push In [Service in Sensor Assy], (NOT SERVICED),
37	04779053	1							GROMMET, Rear Sensor [Service in Sensor Assy], (NOT SERVICED)
-38	06101683	2							BOLT, Hex Head, M6x1.00x35, Rear Wheel Speed Sensor

CONCORDE,INTREPID,VISION,300M,NEW YORKER,LHS (LH)

SERIES LINE BODY
H = HIGHLINE D = Intrepid 41 = 4 Door Sedan
P = PREMIUM C = LHS, Concorde
S = Special Y = 300 M

ENGINE TRANSMISSION
EER = 2.7L V6 DOHC 24 Valve MPI Engine DGX = 4-Speed Automatic Transmission
EGG = 3.5L High Output V6 24V MPI Engine DGO = All Automatic
EGW = 3.2L V6 SOHC 24 Valve MPI Engine

AR = use ase required - = Non illustrated part

1998 LH

Booster, Power Brake

Figure 5-310

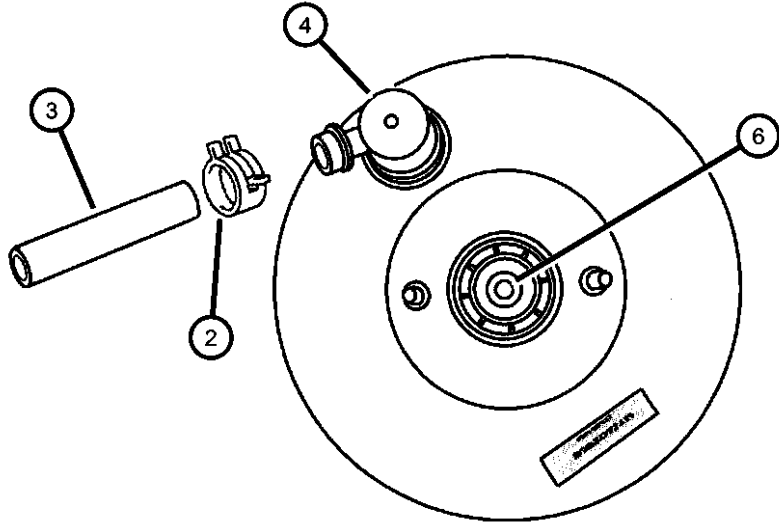

ITEM	PART NUMBER	QTY	LINE	SERIES	BODY	ENGINE	TRANS	TRIM	DESCRIPTION
1	04779072	1							BOOSTER, Power Brake
2	04779072	1							CLAMP, HOSE CLAMP, (NOT REQUIRED)
3	04779832	1							HOSE, Brake Booster Vacuum, with 2.7L Engine .
4	04723391	1							VALVE, Brake Booster Check
-5	04723640	1							GROMMET, Brake Booster Check Valve
6	04723640	1							ROD, Brake Booster, Push Rod M/Cyl. (Service in Booster), (NOT SERVICED)
7	03580171	1							CAP, Brake Check Valve
8	03699447	1							GASKET, Booster To Dash
-9	04583417	1							REINFORCEMENT, Brake Booster
-10	06101445	2							NUT AND WASHER, Hex Nut-Coned Washer, M8 x 1.25, Brake Booster Mount
-11	06502524	2							NUT, Hex Lock, M8x1.25, Brake M/Cylinder to Booster Mount
-12	04779833	1							HOSE, Brake Booster, with 3.3L, 3.5L Engine

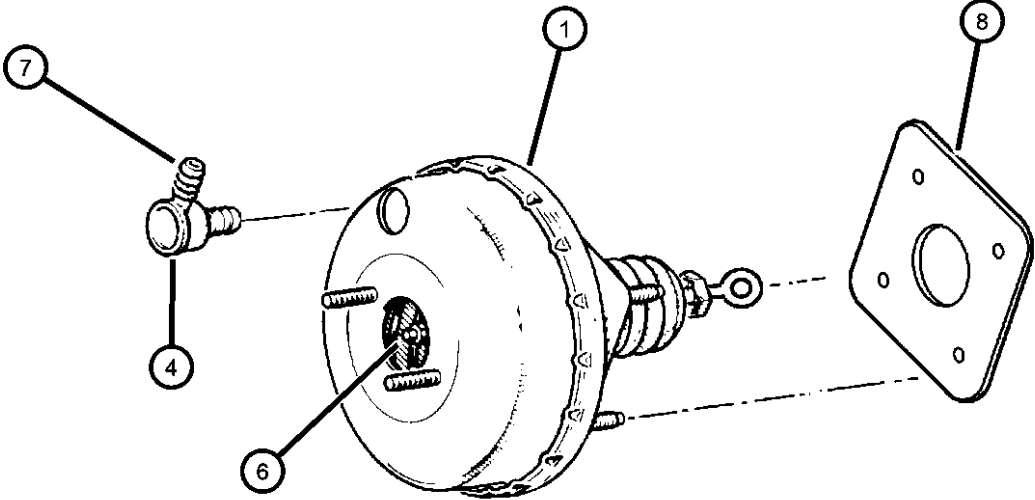

CONCORDE,INTREPID,VISION,300M,NEW YORKER,LHS (LH)

SERIES	LINE	BODY
H = HIGHLINE	D = Intrepid	41 = 4 Door Sedan
P = PREMIUM	C = LHS, Concorde	
S = Special	Y = 300 M	

ENGINE	TRANSMISSION
EER = 2.7L V6 DOHC 24 Valve MPI Engine	DGX = 4-Speed Automatic Transmission
EGG = 3.5L High Output V6 24V MPI Engine	DG0 = All Automatic
EGW = 3.2L V6 SOHC 24 Valve MPI Engine	

AR = use ase required - = Non illustrated part

**Hydraulic Control Unit Anti-lock Brakes
Figure 5-410**

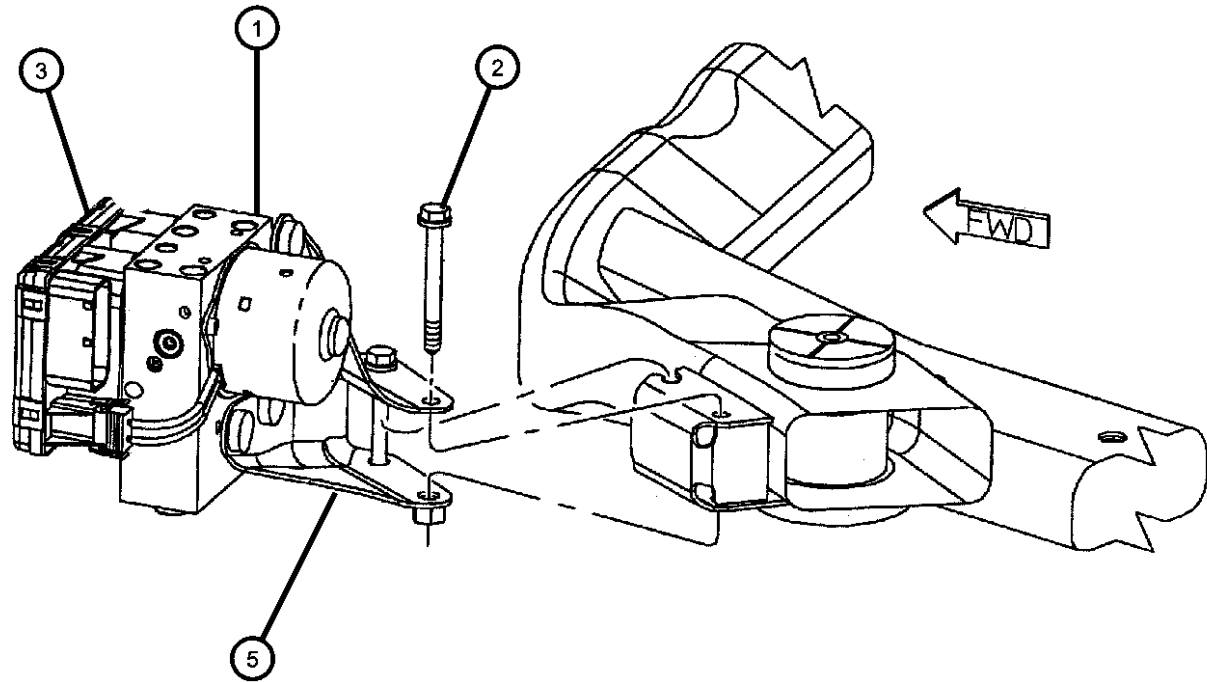

ITEM	PART NUMBER	QTY	LINE	SERIES	BODY	ENGINE	TRANS	TRIM	DESCRIPTION
1	04897780AA	1							HYDRAULIC CONTROL UNIT, Anti-Lock Brake System Without Traction Control
	04897781AA	1							With Traction Control
2	06504766	1							SCREW AND WASHER, Hex Head
3	04602252AA	1	D						MODULE, Anti-Lock Brake System w/o Traction Control
		1	C						w/o Traction Control
	04602253AA	1	D						w/Traction Control
		1	C						w/Traction Control
-4	06504802AA	4							SCREW, 6 Lobed, ECU to HCU M4x0.7x48.50
5	04897785AA	1							BRACKET, Brake Control Unit

CONCORDE,INTREPID,VISION,300M,NEW YORKER,LHS (LH)

SERIES	LINE	BODY
H = HIGHLINE	D = Intrepid	41 = 4 Door Sedan
P = PREMIUM	C = LHS, Concorde	
S = Special	Y = 300 M	

ENGINE	TRANSMISSION
EER = 2.7L V6 DOHC 24 Valve MPI Engine	DGX = 4-Speed Automatic Transmission
EGG = 3.5L High Output V6 24V MPI Engine	DG0 = All Automatic
EGW = 3.2L V6 SOHC 24 Valve MPI Engine	

AR = use ase required - = Non illustrated part

1998 LH

Master Cylinder, Brake
Figure 5-420

ITEM	PART NUMBER	QTY	LINE	SERIES	BODY	ENGINE	TRANS	TRIM	DESCRIPTION
1	04779530	1							MASTER CYLINDER, Brake
2	04509683	1							CAP, Master Cylinder Reservoir
3	05086001AA	1							RESERVOIR, Brake Master Cylinder
4	04723389	2							GROMMET, Master Cylinder Reservoir
5	04723394	2							PIN, Master Cylinder Reservoir
6	04797655	1							SWITCH, Brake Fluid Level

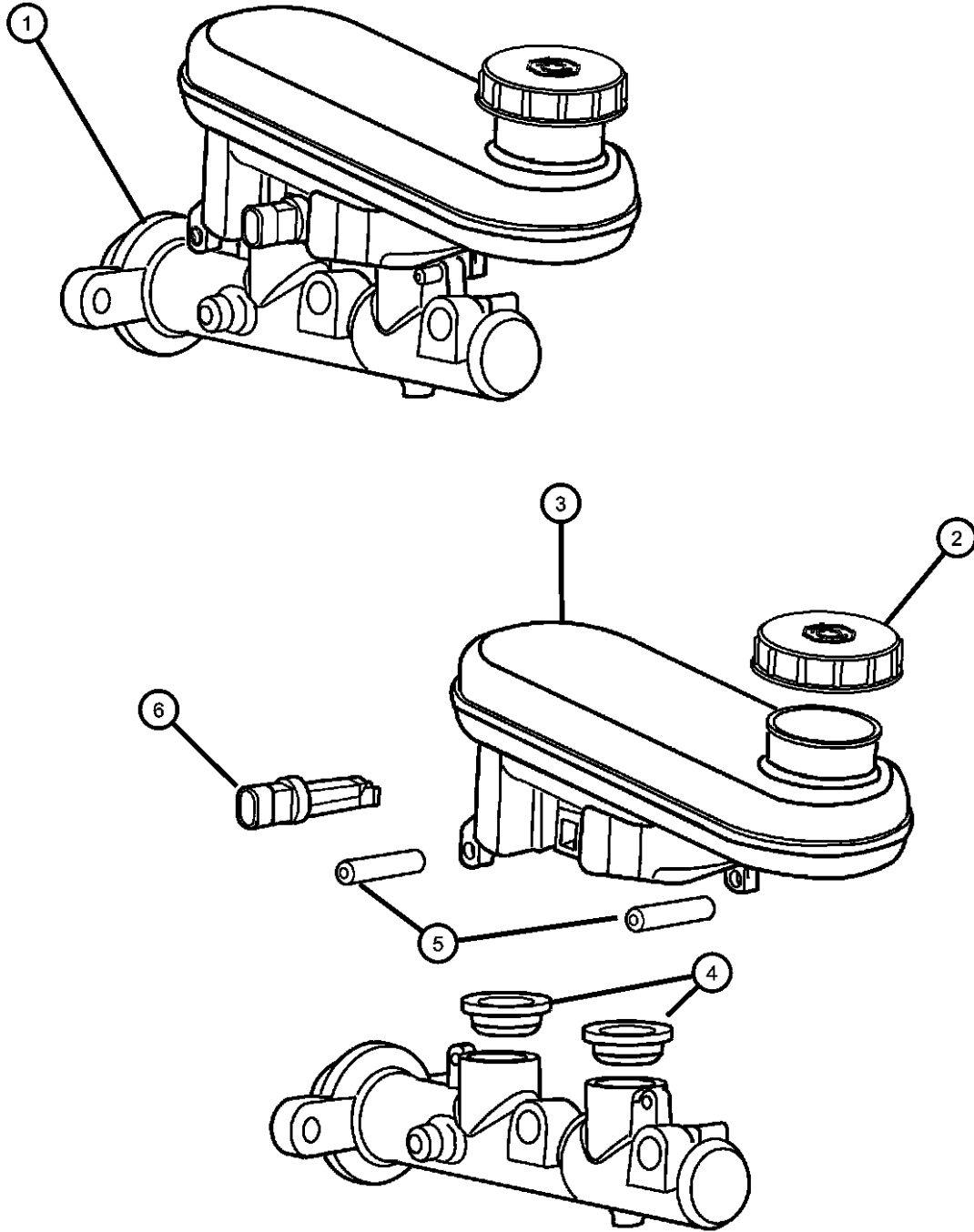

CONCORDE,INTREPID,VISION,300M,NEW YORKER,LHS (LH)

SERIES	LINE	BODY
H = HIGHLINE	D = Intrepid	41 = 4 Door Sedan
P = PREMIUM	C = LHS, Concorde	
S = Special	Y = 300 M	

ENGINE	TRANSMISSION
EER = 2.7L V6 DOHC 24 Valve MPI Engine	DGX = 4-Speed Automatic Transmission
EGG = 3.5L High Output V6 24V MPI Engine	DG0 = All Automatic
EGW = 3.2L V6 SOHC 24 Valve MPI Engine	

AR = use ase required - = Non illustrated part

1998 LH

Lines And Hoses, Front Brakes
Figure 5-510

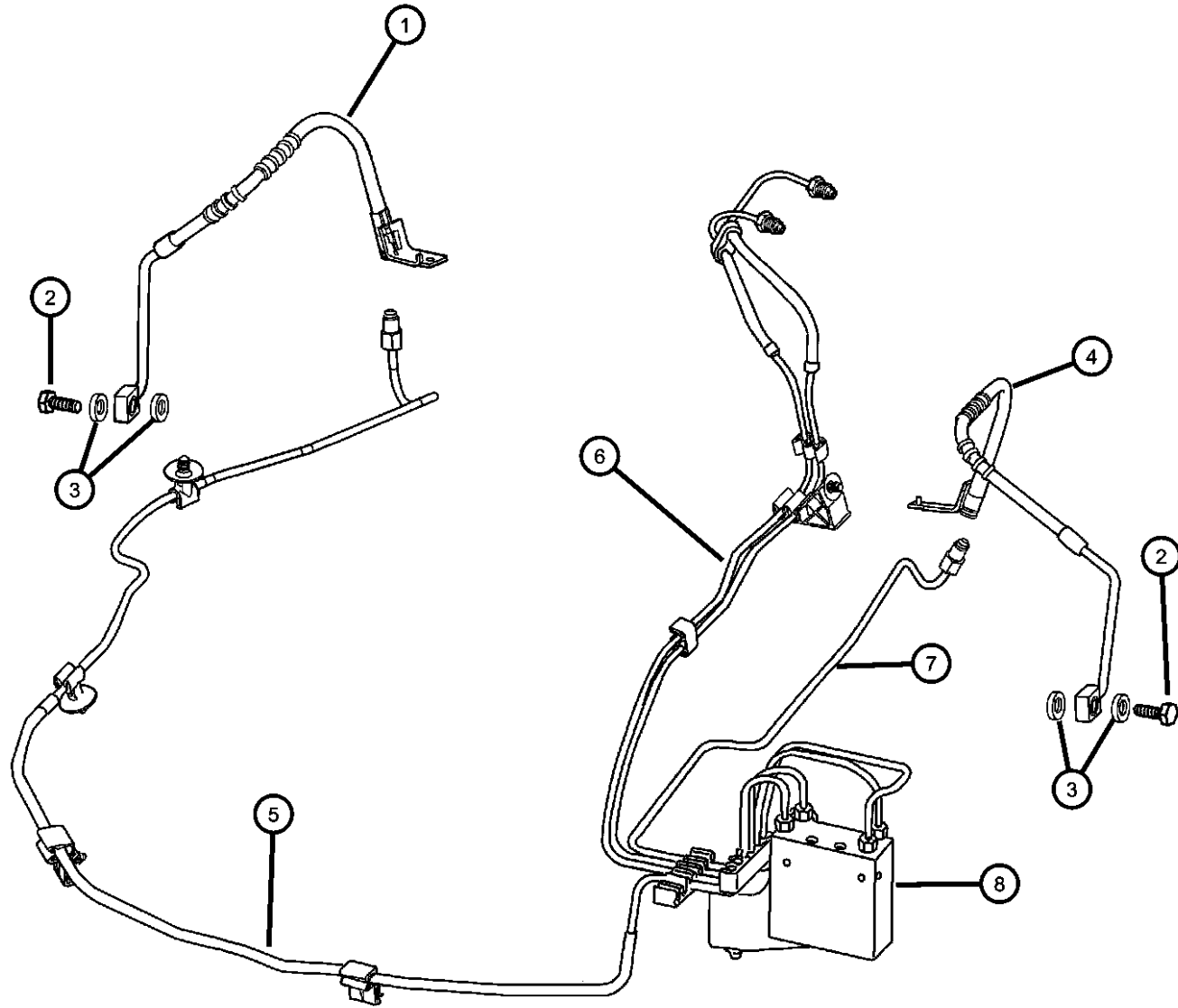

ITEM	PART NUMBER	QTY	LINE	SERIES	BODY	ENGINE	TRANS	TRIM	DESCRIPTION
1	04779120AA	1							HOSE, BrakeRight Front
2	06035098	2							BOLT, Hex Head, .437-20x.937
3	06034942	4							WASHER
4	04779121AA	1							HOSE, BrakeLeft Front
5	04779748	1							TUBE, Brake, Hydraulic Control Unit to Right Front Hose, with Clips
6	04779065	1							TUBE BUNDLE, Brake, to Master Cylinder with Clips
7	04779749	1							TUBE, Brake, Hydraulic Control Unit to Left Hose
8	04779080	1							JUNCTION BLOCK, Brake Tube

CONCORDE,INTREPID,VISION,300M,NEW YORKER,LHS (LH)

SERIES	LINE	BODY
H = HIGHLINE	D = Intrepid	41 = 4 Door Sedan
P = PREMIUM	C = LHS, Concorde	
S = Special	Y = 300 M	

ENGINE	TRANSMISSION
EER = 2.7L V6 DOHC 24 Valve MPI Engine	DGX = 4-Speed Automatic Transmission
EGG = 3.5L High Output V6 24V MPI Engine	DG0 = All Automatic
EGW = 3.2L V6 SOHC 24 Valve MPI Engine	

AR = use ase required - = Non illustrated part

Lines and Hoses, Rear Brakes
Figure 5-520

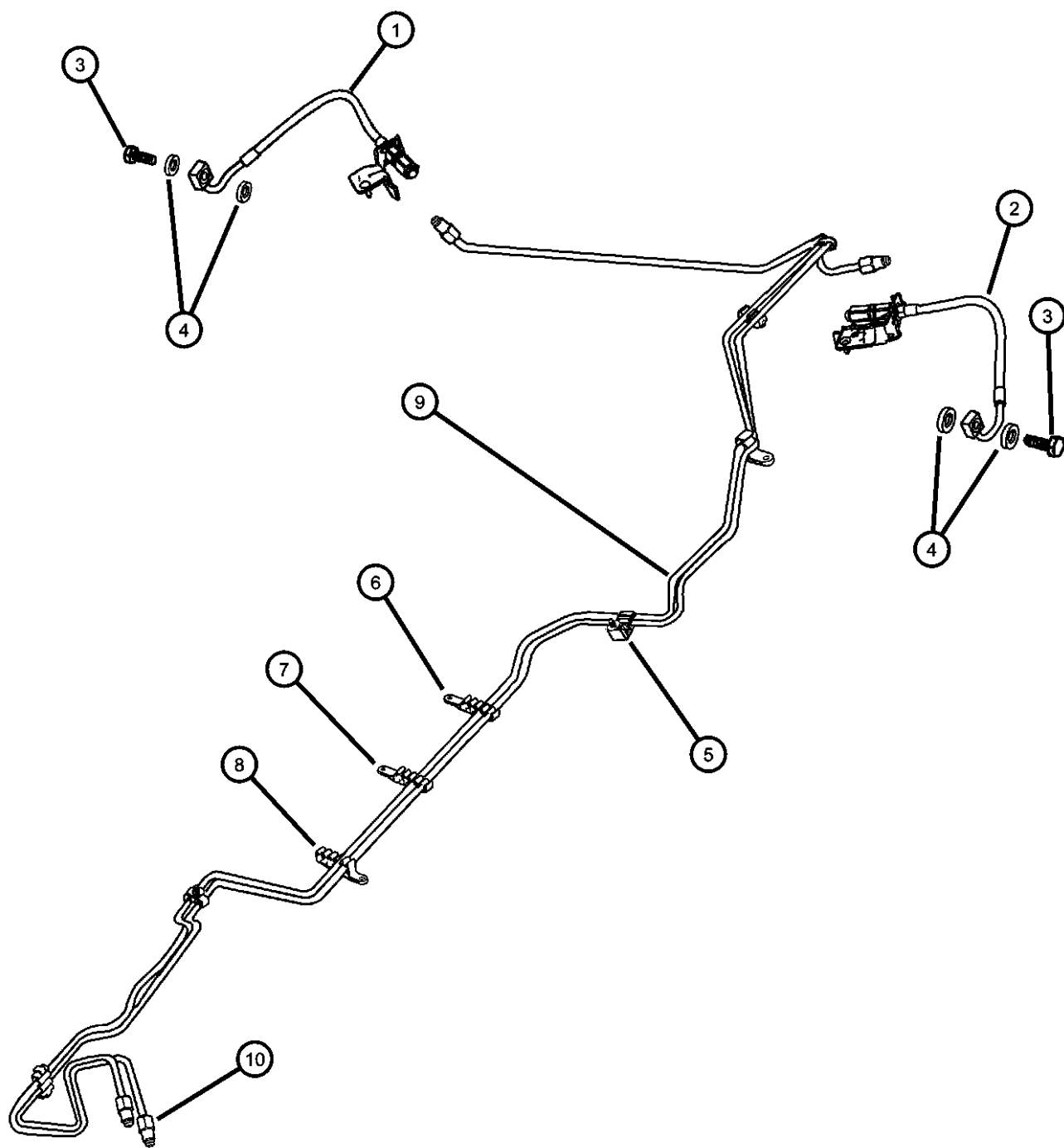

ITEM	PART NUMBER	QTY	LINE	SERIES	BODY	ENGINE	TRANS	TRIM	DESCRIPTION
1	04779012AB	1							HOSE, BrakeRight Rear
2	04779013AB	1							HOSE, BrakeLeft Rear
3	06035098	2							BOLT, Hex Head, .437- 20x.937Brake Hose Attaching
4	06034942	4							WASHER, Brake Hose, .446 ID .688 OD Copper
5	05011478AA	1							CLIP, Fuel Line
6	05010231AA	1							CLIP, Fuel Line
7	05011478AA	1							CLIP, Fuel Line
8	05010230AA	1							CLIP, Fuel Line
9	01843251	1							TUBE, Steel, .187 25 Foot Roll
10									NUT, Brake Line
	05014835AA	1							M10
	05014836AA	1							M12

CONCORDE,INTREPID,VISION,300M,NEW YORKER,LHS (LH)

SERIES	LINE	BODY
H = HIGHLINE	D = Intrepid	41 = 4 Door Sedan
P = PREMIUM	C = LHS, Concorde	
S = Special	Y = 300 M	

ENGINE	TRANSMISSION
EER = 2.7L V6 DOHC 24 Valve MPI Engine	DGX = 4-Speed Automatic Transmission
EGG = 3.5L High Output V6 24V MPI Engine	DG0 = All Automatic
EGW = 3.2L V6 SOHC 24 Valve MPI Engine	

AR = use ase required - = Non illustrated part