



Service Manual

Models G5-18A & 2505H

Agrovector 25.5

S/N 0160053000 & After including
0160051045, 0160051047, 0160051049,
0160051194 & 0160051359

31200926

*Original
May 9, 2013*



EFFECTIVITY PAGE

May 9, 2013 - A - Original Issue Of Manual

READ THIS FIRST

Modifications

Modifications to this machine may affect compliance with Industry Standards and/or Governmental Regulations. Any modification must be approved by JLG.

Machine Configuration

Two configurations of each machine are included in this manual. Determine if machine is equipped with Ultra Low Sulfur Fuel Decal (1) as indicated below.

- If equipped with the Ultra Low Sulfur decal, all specific references to this machine configuration will be referred to as Ultra Low Sulfur (**ULS**) from this point forward.
- If **not** equipped with the Ultra Low Sulfur decal, all specific references to this machine configuration will be referred to as Low Sulfur (**LS**) from this point forward.

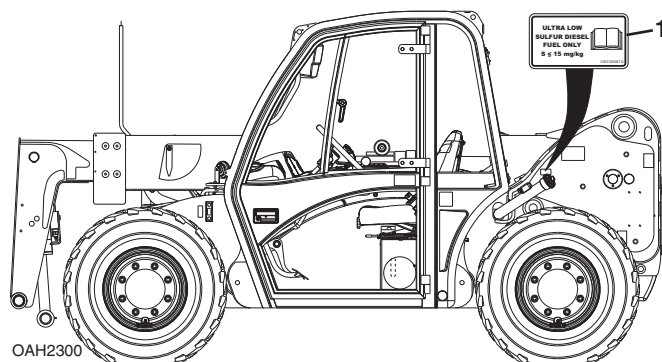

SECTION CONTENTS

Section	Subject	Page
Section 1		
Safety Practices		1-1
1.1	Introduction	1-2
1.2	Disclaimer	1-2
1.3	Operation & Safety Manual	1-2
1.4	Do Not Operate Tags	1-2
1.5	Safety Information	1-2
1.6	Safety Instructions	1-3
1.7	Safety Decals	1-4
Section 2		
General Information and Specifications		2-1
2.1	Replacement Parts and Warranty Information	2-2
2.2	Torque Charts	2-3
2.3	Specifications	2-11
2.4	Fluids, Lubricants and Capacities	2-13
2.5	Maintenance Schedule	2-16
2.6	Lubrication Schedule	2-19
Section 3		
Boom		3-1
3.1	Boom System Component Terminology	3-2
3.2	Safety Information	3-3
3.3	Two Section Boom System	3-3
3.4	Boom Assembly Maintenance	3-3
3.5	Boom Wear Pads	3-9
3.6	Quick Attach Assembly	3-10
3.7	Forks	3-11
3.8	Boom Prop (If Equipped)	3-12
3.9	Emergency Boom Lowering Procedure	3-13
3.10	Troubleshooting	3-15
Section 4		
Cab		4-1
4.1	Operator Cab Component Terminology	4-2
4.2	Safety Information	4-3
4.3	Operator Cab	4-3
4.4	Cab Components	4-3
4.5	Cab Removal	4-10
4.6	Cab Installation	4-11

Section	Subject	Page
Section 5		
Axles, Drive Shafts, Wheels and Tires		5-1
5.1	Axle, Drive Shaft and Wheel Component Terminology	5-2
5.2	Safety Information	5-3
5.3	General Information	5-3
5.4	Axle Assemblies	5-3
5.5	Drive Shafts	5-9
5.6	Wheels and Tires	5-10
5.7	Steering Angle Adjustment	5-11
5.8	Brakes	5-11
5.9	Towing a Disabled Machine	5-12
Section 6		
Transmission		6-1
6.1	Transmission Assembly Component Terminology	6-2
6.2	Safety Information	6-3
6.3	Transmission Description	6-3
6.4	Transmission Specifications	6-3
6.5	Transmission Replacement	6-3
Section 7		
Engine		7-1
7.1	Introduction	7-2
7.2	Engine Cooling System	7-4
7.3	Engine Electrical System	7-7
7.4	Fuel System	7-7
7.5	Engine Exhaust System	7-8
7.6	Air Cleaner Assembly	7-10
7.7	Engine Replacement	7-11
Section 8		
Hydraulic System		8-1
8.1	Hydraulic Component Terminology	8-3
8.2	Safety Information	8-4
8.3	General Information	8-4
8.4	Specifications	8-4
8.5	Hoses, Tube Lines, Fittings, Etc.	8-4
8.6	Hydraulic Pressure Diagnosis	8-5
8.7	Hydraulic Schematic	8-7
8.8	Hydraulic Reservoir	8-10
8.9	Hydraulic System Pump	8-11
8.10	Front Drive Motor	8-12
8.11	Control Valves	8-13
8.12	Hydraulic Cylinders	8-26

Section 9

Electrical System		9-1
9.1	Electrical Component Terminology	9-3
9.2	Safety Information	9-4
9.3	Fuses and Relays	9-4
9.4	Electrical System Schematics	9-7
9.5	Engine Start Circuit	9-15
9.6	Charging Circuit	9-17
9.7	Electrical System Components	9-18
9.8	Window Wiper/Washer	9-19
9.9	Cab Heater/AC and Fan	9-21
9.10	Switches, Solenoids and Senders	9-22
9.11	Load Stability Indicator System (2505H & 25.5)	9-26
9.12	Hand Held Analyzer (2505H & 25.5)	9-32
9.13	Diagnostic Trouble Codes (DTC) on Ground Module	9-34
9.14	Engine Diagnostic Trouble Code EMR4	9-39



Section 1

Safety Practices

Contents

PARAGRAPH	TITLE	PAGE
1.1	Introduction	1-2
1.2	Disclaimer	1-2
1.3	Operation & Safety Manual.....	1-2
1.4	Do Not Operate Tags.....	1-2
1.5	Safety Information.....	1-2
1.5.1	Safety Alert System and Signal Words.....	1-2
1.6	Safety Instructions	1-3
1.6.1	Personal Hazards	1-3
1.6.2	Equipment Hazards.....	1-3
1.6.3	General Hazards.....	1-3
1.6.4	Operational Hazards.....	1-4
1.7	Safety Decals.....	1-4

**Safety Practices****1.1 INTRODUCTION**

This service manual provides general directions for accomplishing service and repair procedures. Following the procedures in this manual will help assure safety and equipment reliability.

Read, understand and follow the information in this manual, and obey all locally approved safety practices, procedures, rules, codes, regulations and laws.

These instructions cannot cover all details or variations in the equipment, procedures, or processes described, nor provide directions for meeting every possible contingency during operation, maintenance, or testing. When additional information is desired consult the local **JLG** Dealer.

Many factors contribute to unsafe conditions: carelessness, fatigue, overload, inattentiveness, unfamiliarity, even drugs and alcohol, among others. For optimal safety, encourage everyone to think, and to act, safely.

Appropriate service methods and proper repair procedures are essential for the safety of the individual doing the work, for the safety of the operator, and for the safe, reliable operation of the machine. All references to the right side, left side, front and rear are given from the operator's seat looking in a forward direction.

Supplementary information is available from **JLG** in the form of Service Bulletins, Service Campaigns, Service Training Schools, the **JLG** website, other literature and through updates to the manual itself.

1.2 DISCLAIMER

All information in this manual is based on the latest product information available at the time of publication. **JLG** reserves the right to make changes and improvements to its products, and to discontinue the manufacture of any product, at its discretion at any time without public notice or obligation.

1.3 OPERATION & SAFETY MANUAL

The mechanic must not operate the machine until the Operation & Safety Manual has been read and understood, training has been accomplished and operation of the machine has been completed under the supervision of an experienced and qualified operator.

An Operation & Safety Manual is supplied with each machine and must be kept in the manual holder located in the cab. In the event that the Operation & Safety Manual is missing, consult the local **JLG** Dealer before proceeding.

1.4 DO NOT OPERATE TAGS

Place Do Not Operate Tags on the ignition key switch and the steering wheel before attempting to perform any service or maintenance. Remove key and disconnect battery leads.

1.5 SAFETY INFORMATION

To avoid possible death or injury, carefully read, understand and comply with all safety messages.

In the event of an accident, know where to obtain medical assistance and how to use a first-aid kit and fire extinguisher/fire suppression system. Keep emergency telephone numbers (fire department, ambulance, rescue squad/paramedics, police department, etc.) nearby. If working alone, check with another person routinely to help assure personal safety.

1.5.1 Safety Alert System and Signal Words

DANGER indicates an imminently hazardous situation which, if not avoided, will result in death or serious injury.



WARNING indicates a potentially hazardous situation which, if not avoided, could result in death or serious injury.



CAUTION indicates a potentially hazardous situation which, if not avoided, may result in minor or moderate injury.