

Anhang zum Werkstatthandbuch Supplement to Workshop Manuel Annexe au le Manuel d'atelier Anexo al Manual de taller

B/FL 413 R/FR/FRW

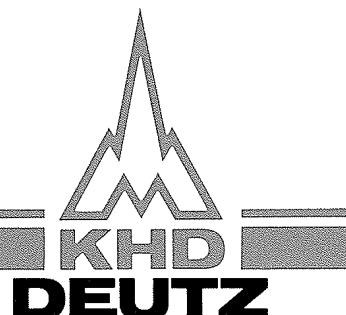

BF 6 L 513 R/RC

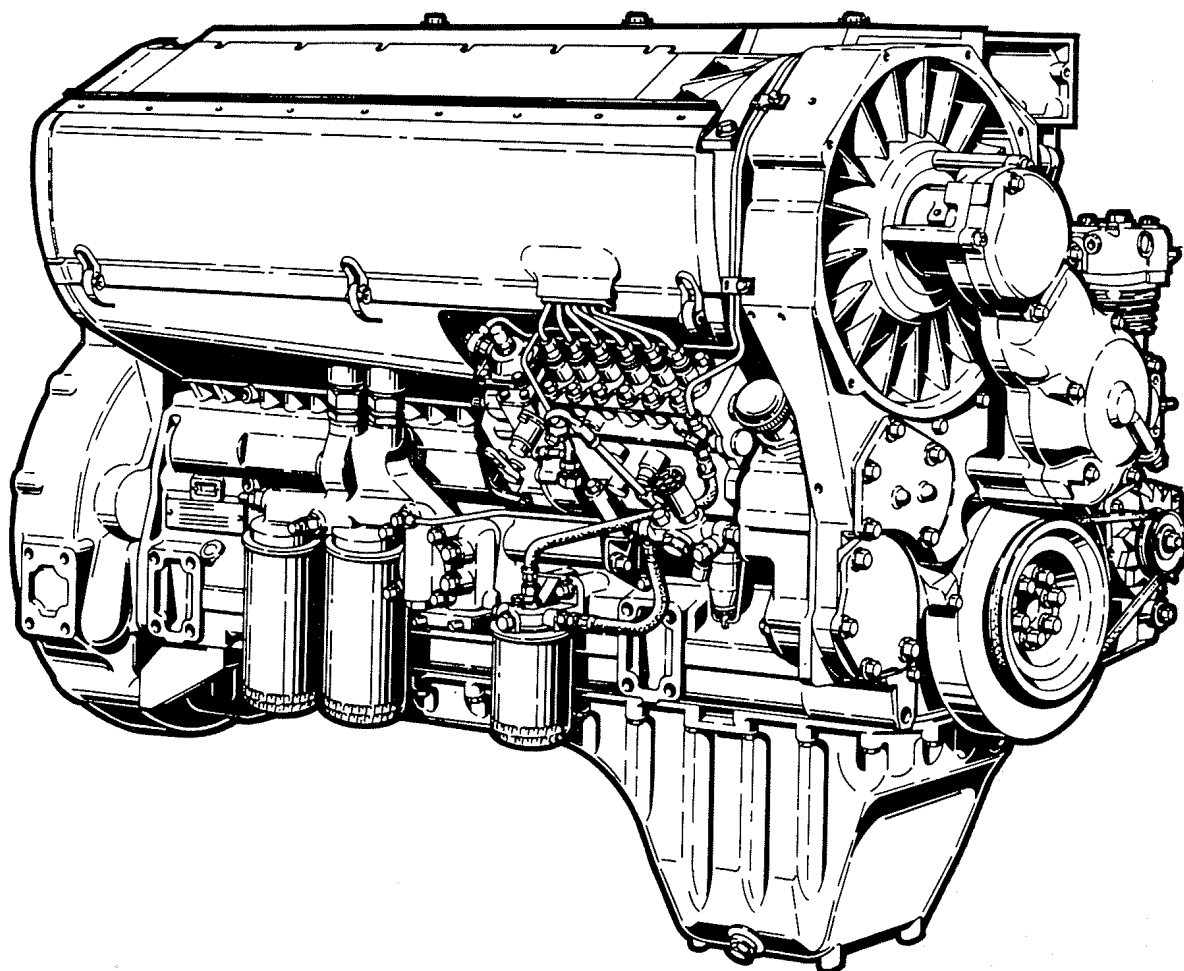

Anhang zum Werkstatthandbuch

Supplement to Workshop Manuel

Annexe au le Manuel d'atelier

Anexo al Manual de taller

BIFL 413R/FR/FRW

Nr. 291 1879 Ausgabe 12 / 1983

BF6L 513R/RC

<i>Drucksachen Nr.</i> <i>Printed material no.</i> <i>No. de l'imprime</i> <i>Impresso No</i>	291 1941
--	-----------------

<i>Ausgabe Datum</i> <i>Date of issue</i> <i>Date d'edition</i> <i>Fecha de edición</i>	05 / 1988
--	------------------

Herausgeber :
Klöckner - Humboldt - Deutz AG, Köln
Abteilung AZ-MD 3 , Kundendienst
5000 Köln, Postfach 80 05 09
Telefon 0221 - 8221, Telex 8812 - 0

Alle Rechte vorbehalten - Printed in Germany

Diese Druckschrift darf ohne unsere schriftliche Genehmigung
weder ganz noch auszugsweise vervielfältigt werden.
Änderungen und Irrtum vorbehalten.

Published by :
Klöckner - Humboldt - Deutz AG, Cologne
Dept. AZ-MD 3 , Service
5000 Köln, P.O. Box 80 05 09
Telephone 0221 - 8221, Telex 8812 - 0

All rights reserved - Printed in Germany

This publication may not be produced in any form, in whole or
in part, without our written approval.
Errors and omissions excepted.

Editeur :
Klöckner - Humboldt - Deutz AG, Cologne
Dept. AZ-MD 3 , Service Après Vente
5000 Köln, Boite postae 80 05 09
Téléphone 0221 - 8221, Telex 8812 - 0

Tous droits réservés - Imprimé en Allemagne

Toute reproduction intégrale ou partielle de notre Manuel
d'Atelier est interdite sans notre consentement écrit.
Sous réserve de modifications et d'erreurs.

Edita :
Klöckner - Humboldt - Deutz AG, Köln
Sección AZ-MD 3 , Servicio posventa
5000 Köln, Apartado 80 05 09
Teléfono 0221 - 8221, Télex 8812 - 0

Todos los derechos reservados - Printed in Germany

Sin nuestro expreso consentimiento por escrito no se podrá
facilitar el presente impreso, ni parcial, ni totalmente a
terceros, ni tampoco sacar copial del mismo.
Reservado el derecho de modificación. S.e.u.o.



VORWORT

Der Anhang zum Werkstatthandbuch informiert unsere Kunden und Service-Partner über Reparatur- und Einstellarbeiten am BF6L 513 R-Motor. Alle im Anhang nicht aufgeführten Arbeiten sind aus dem Werkstatthandbuch zu entnehmen. Dabei wird vorausgesetzt, daß die Arbeiten von Fachpersonal ausgeführt werden.

Die Gestaltung dieses Anhanges ermöglicht die schnelle visuelle Erfassung der Inhalte, hierzu sind neben dem Bild grafische Symbole - Bildzeichen - gesetzt worden. Die Bildzeichen stehen anstelle von Texten. Damit wird eine universelle Anwendbarkeit möglich, da die Bild- und Symbolaussage auch für Sprachunkundige weitgehend verständlich ist.

Betriebs- und Wartungshinweise sind im Anhang nicht enthalten; diese befinden sich in der zum Motor gehörenden Betriebsanleitung.

Der Anhang unterliegt keinem Änderungsdienst. Bei der Neuauflage werden Änderungen berücksichtigt. Wir verweisen in diesem Zusammenhang auf die Technischen Rundschreiben, mit denen Änderungen fortlaufend bekanntgegeben werden.

Allgemeine Hinweise:

Lesen und beachten Sie die Informationen dieses Anhanges und des Werkstatthandbuches. Sie vermeiden Unfälle und verfügen über einen funktionstüchtigen und einsatzbereiten Motor.

Stellen Sie sicher, daß dieser Anhang und das Werkstatthandbuch jedem an Reparatur- oder Einstellarbeiten Beteiligten zur Verfügung steht und daß der Inhalt verstanden wird.

Die Nichtbeachtung dieser Reparaturanleitungen kann zu Funktionsstörungen und Motorschäden sowie Verletzungen von Personen führen, für die vom Hersteller keine Haftung übernommen wird.

Voraussetzung für die fachgerechte Reparatur ist die Verfügbarkeit aller erforderlichen Ausrüstungen, Hand- und Spezialwerkzeuge sowie deren einwandfreier Zustand.

Höchste Wirtschaftlichkeit, Zuverlässigkeit und lange Lebensdauer ist nur bei Verwendung von Original DEUTZ Ersatzteilen sichergestellt.

Motorteile wie Federn, Klammern, elastische Halteringe etc. beinhalten bei unsachgemäßer Behandlung erhöhte Verletzungsgefahr.

Die Instandsetzung des Motors muß der bestimmungsgemäßen Verwendung - definiert durch den Gerätehersteller - entsprechen. Bei Umbauten dürfen nur von DEUTZ für den jeweiligen Verwendungszweck freigegebene Teile eingesetzt werden.

FOREWORD

This Annex to the Workshop Manual informs our customers and service partners about repair and adjustment work on the BF6L 513 R engine. Any work not described in this Annex can be found in the Workshop Manual. It is presumed that this work will be carried out by qualified personnel.

This Annex has been made up in a manner which ensures quick visual comprehension of the contents. This is achieved by illustrations and graphic symbols as substitute for the respective text. This layout permits universal use, because the illustrations and symbols are also largely understood by those being unable to read and write.

Aspects of operation and maintenance are not dealt with in this Annex; they are contained in the Engine Operation Manual.

This Annex is not regularly updated. Any engineering changes having been introduced in the meantime will be considered in the next issue. Therefore, please refer to the Technical Circulars where engineering changes are announced when appropriate.

General:

Please read and note carefully the information given in this Annex and the Workshop Manual. This will avoid accidents and will help to ensure that your engine always functions properly and reliably.

Make sure that this Annex and the Workshop Manual are readily available to everybody carrying out repair or adjustments and that the instructions are well understood.

Failure to comply with these repair instructions may result in engine malfunction and damage as well as personal injury for which the manufacturer will not accept any liability.

A prerequisite for successful repair is that all required equipment, hand and special tools are available and in perfect condition.

Economic operation, reliability and durability of the engine can be ensured only if genuine DEUTZ parts are used.

Remember that such engine components as springs, clips, snap rings, etc. involve the risk of injury if not handled with care.

Engine overhauls must be based on the relevant engine duty schedule - as defined by the equipment manufacturer. For conversions only such parts should be used which DEUTZ develops and supplies specifically for this purpose.

AVANT-PROPOS

L'Annexe du Manuel d'Atelier informe nos clients et partenaires du service après vente des travaux de réparation et de réglage à effectuer sur le moteur BF6L 513 R. Tous les travaux qui ne seraient pas mentionnés à l'Annexe figurent dans le Manuel d'Entretien. Nous supposons que ces travaux seront effectués par un personnel parfaitement qualifié.

La conception du présent Manuel d'Atelier permet une vision rapide du contenu grâce aux symboles - figures - disposés à côté de chaque photo. Les symboles remplacent le texte et permettent une utilisation universelle étant donné que les symboles et figures sont compréhensibles de tous.

Le Manuel d'Atelier ne contient pas les instructions de conduite et d'entretien; celles-ci figurent dans le Manuel d'Instructions de chaque moteur.

Le Manuel d'Atelier n'est pas mis à jour. Les modifications ne sont prises en considération que lors de sa réédition. Dans ce même ordre d'idées, nous attirons votre attention sur les Circulaires Techniques par lesquelles les modifications sont publiées continuellement.

Remarques générales:

Veuillez lire et tenir compte des informations contenues dans la présente Annexe du Manuel d'entretien et dans le Manuel même. Vous éviterez des accidents et disposerez d'un moteur fonctionnel et en parfait état de marche.

Assurez-vous que chaque personne chargée de travaux de réparation et de réglage dispose bien de la présente Annexe et du Manuel d'Atelier et en a bien compris le contenu.

Le non-respect de ces instructions de réparation peut entraîner des pannes, des avaries de moteur et accidents de personnes, pour lesquels le constructeur ne peut assumer aucune responsabilité.

La condition préalable de la bonne exécution des réparations est la mise à disposition de tous les équipements, outillages manuels et spéciaux requis, en parfait état de fonctionnement.

Seule l'utilisation de pièces de rechange d'origine DEUTZ garantit une rentabilité et une fiabilité optimales ainsi qu'une longue durée de vie.

Les éléments du moteur notamment les ressorts, attaches, bagues élastiques etc., peuvent entraîner, en cas de non-respect des prescriptions, des blessures graves.

La remise en état du moteur doit répondre à son utilisation propre, définie par le constructeur de l'engin. En cas de modification, seules les pièces autorisées par DEUTZ dans le cas de l'application concernée, peuvent être utilisées.



PREFACIO

El suplemento para el Manual de Taller informa a nuestros clientes y al personal de nuestros puntos de servicio autorizados sobre trabajos de reparación y puesta a punto en el motor BF6L 513 R. Todos los trabajos no indicados en el suplemento se pueden desprender del Manual de Taller. Se presupone que dichos trabajos son realizados por personal especializado.

La organización de este suplemento permite la rápida orientación visual del usuario sobre el contenido del mismo, gracias a los símbolos gráficos que acompañan a las figuras en sustitución de informaciones escritas y que son prácticamente comprensibles para todos pues no requieren conocimientos lingüísticos.

Indicaciones referentes a la operación y al mantenimiento de los motores no figuran en el presente suplemento pero sí en el Manual de Instrucciones correspondiente.

No existe servicio de notificación de modificaciones para este suplemento, teniéndose en cuenta en cada nueva edición las modificaciones que se produzcan. En este contexto, les remitimos a las Circulares Técnicas, en las cuales se dan a conocer continuamente las modificaciones introducidas.

Advertencias generales:

Le recomendamos la detenida lectura y observancia de las informaciones contenidas en este suplemento y el Manual de Taller. Así evitará accidentes y dispondrá de un motor que funciona perfectamente.

Haga lo necesario para que este suplemento y el Manual de Taller estén a disposición de toda persona que participe en trabajos de reparación y ajuste, y cuide de que se comprenda el contenido.

Al no tenerse en cuenta estas instrucciones de reparación, podrán surgir perturbaciones en el funcionamiento y averías en el motor así como lesiones de personas para las cuales el fabricante no asume responsabilidad alguna.

Es condición para la correcta reparación que estén disponibles todos los requeridos equipos, herramientas manuales y especiales en perfecto estado.















Máxima rentabilidad, fiabilidad y larga duración quedan garantizadas únicamente al emplearse repuestos originales DEUTZ.

Piezas del motor tales como resortes, garras, aros de sujeción elásticos, etc., aumentan en caso de tratamiento incorrecto el peligro de lesiones.













El reacondicionado del motor deberá corresponder al empleo previsto definido por el fabricante del equipo. En caso de transformaciones, se deberán emplear únicamente piezas admitidas por DEUTZ para el respectivo uso previsto.















Bildzeichenerklärung

	Zerlegen von Baugruppen
	Zusammenbauen zu einer Baugruppe
	Abbauen – Ausbauen behindernder Teile
	Einbauen – Anbauen Teile, die beim Ab-/ Ausbau hinderten
	Achtung, wichtiger Hinweis
	Prüfen – Einstellen z. B. Drehmomente, Maße, Drücke usw.
	Spezialwerkzeug.
	Einbaurichtung beachten
	Kontrollieren – Prüfen Sichtprüfung
	Bedingt wiederverwendbar Bei Bedarf auswechseln
	Beim Zusammenbau immer erneuern
	Entsichern – Sichern z. B. Splint, Sicherungsblech usw.
	Sichern – Kleben z. B. Dichtmittel flüssig













	Personenschaden verhüten Hinweis auf Gefahrenstelle
	Materialschaden verhüten Teilbeschädigung
	Unterbauen – Abstützen – Abfangen
	Einölen
	Einfetten
	Markieren vor dem Zerlegen, beachten beim Zusammenbau
	Wuchten Ausgleichen von Unwuchten
	Einfüllen – Auffüllen – Nachfüllen z. B. Öl, Kühlwasser usw.
	Ablassen z. B. Öl, Kühlwasser usw.
	Lösen z. B. Lockern einer Spanneinrichtung
	Spannen z. B. Anziehen einer Spanneinrichtung
	Entlüften
	Spanabhebende Bearbeitung
	Siehe Techn. Daten (Zeilenhinweis z. B. 67)















Key to Symbols

	Disassembly of assembly groups
	Reassemble to form assembly group
	Remove obstructing parts
	Reinstall – Remount parts which had obstructed disassembly
	Attention! Important notice!
	Check – Adjust e. g. torque, dimensions, pressures, etc.
	Special tool
	Note direction of installation
	Visual inspection
	Possibly still serviceable Renew if necessary
	Renew at each reassembly
	Unlock – Lock e. g. split pin, locking plate, etc.
	Lock – Adhere e. g. with liquid sealant









	Guard against personal injury Indication of hazard
	Guard against material damage Damage to parts
	Prop up – Support – Hold
	Oil
	Grease
	Mark before disassembly, observe marks when reassembling
	Balance Eliminate any imbalance
	Filling – Topping up – Refilling e. g. oil, cooling water, etc.
	Drain off e. g. oil, cooling water, etc.
	Loosen – Release e. g. loosening a clamping device
	Tighten – Clamp e. g. tightening a clamping device
	Vent
	Machining process
	See Technical Data (For inst. 67 as indication of the line)















Légende des symboles

	Désassemblage d'un ensemble constructif
	Assemblage des composants d'un ensemble constructif
	Démontage d'éléments entravant l'accès
	Remontage – Remise en place d'éléments qui entravaient l'accès
	Remarque importante!
	Vérifier – régler p. ex. : couple-moteur, cotes, pressions etc.
	Utilisation impérative d'un outil spécialisé
	Respecter l'ordre de montage
	Vérification – Contrôle à vue
	Réutilisation sous certaines conditions à remplacer, si besoin est
	A remplacer systématiquement lors du remontage
	Arracher la goupille – goupiller freiner par tôle-arrêt
	Freiner – coller p. ex. avec pâte hermétique, ou frein liquide

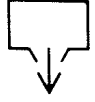
	Prévention aux accidents professionnels attirer l'attention sur un risque éventuel d'accident
	Prévention à la détérioration de matériels Risque d'endommager des pièces
	Monter sur tréteaux – freiner par sabots – immobiliser par un moyen quelconque
	Huiler
	Graisser employer lubrifiant plastique
	Repérage en cours de démontage permet un remontage correct!
	Equilibrer éliminer le balourd
	Premier garnissage – remplissage – garnissage d'appoint p. ex. : Huile, eau de refroidissement etc.
	Vidanger – soutirer p. ex. : Huile eau de refroidissement etc.
	Desserrer p. ex. desserrage d'un dispositif
	Serrer p. ex. : serrage entre un dispositif
	Faire la purge d'air
	Usinage par enlèvement de copeaux
	Voir caractéristiques techniques (par ex. 67 comme indication de ligne)

Leyenda de símbolos

	Desarmar grupos de construcción
	Rearmar un grupo de construcción
	Desmontar partes que estorbasen
	Montar – Incorporar partes que hubiesen estorbado en el desmontaje
	¡Atención! Indicación importante
	Verificar – Graduar – Ajustar (p. ej. pares, medidas, presiones, etc.)
	Herramienta especial
	Observar la dirección de montaje
	Control verificación visual
	Re-utilización condicional sustituir en caso necesario
	Sustituir a cada montaje
	Desafianzar – Afianzar (mecánicamente) (p. ej. pasador de aletas, chapa de seguridad, etc.)
	Afianzar – Pegar p. ej. con medio líquido

	Evitar accidentes indicar sobre puntos de peligro
	Evitar daños de materiales avería de piezas
	Calzar – Apoyar
	Aceitar
	Engrasar
	Marcar antes del desmontaje – controlar la marca- ción en el remontaje
	Equilibrar eliminar desequilibrios o excentricidad
	Llenar – Rellenar – Completar p. ej. aceite, agua refrigerante, etc.
	Evacuar – Vaciar p. ej. aceite, agua refrigerante, etc.
	Soltar p. ej. un sistema de fijación o tensado
	Tensar – Apretar p. ej. un sistema de fijación o tensado
	Purgar el aire
	Mecanización con arranque de virutas
	Véase (p. ej. línea 67) bajo Datos Técnicos

Inhaltsverzeichnis

Contents

Table des matières

Indice

1	Techische Daten	Caractéristiques techniques
	Specification data	Datos técnicos
2	Prüfung und Einstellung	Vérification et réglage
	Tests, Checks, Inspections, Settings	Verificación y ajuste
3	Bauteile - Instandsetzung	Remise en état des composants
	Repairing Components	Reacondicionado de elementos de construcción
4	Demontage und Montage Motor komplett	Démontage et montage moteur complet
	Dismantling and Reassembling, engine complete	Desmontaje y montaje, motor completo
5	Abgasturbolader	Turbocompresseur
	Turbochargers	Turbo - sobrealimentador
6	Spezialwerkzeug	Outils spécial
	Special Tools	Herramientas especiales

Inhaltsverzeichnis

1. TECHNISCHE DATEN

Seite

000	Allgemeine Motordaten	1/1	-	1/2
001	Motorgewichte			1/1
100	Einspritzanlage	1/3	-	1/5
110	Einspritzpumpe			1/3
120	Regler			1/3
130	Einspritzdüse			1/4
140	Förderbeginn			1/5
200 - 400	Zylindereinheit	1/6	-	1/18
200	Zylinderkopf	1/6	-	1/13
210	Ventilführung			1/6
220	Ventilsitzring			1/6
230	Ventil	1/7	-	1/9
250	Ventilfeder			1/10
260	Ventilspiel			1/11
270	Kontroll - Abstände			1/12
280	Zylinderkopfschrauben			1/13
300	Zylinder			1/14
400	Kolben	1/15	-	1/16
420	Kolbenringe	1/17	-	1/18
500 - 700	Triebwerk	1/19	-	1/28
500	Kurbelwelle			1/19
510	Hublagerzapfen			1/19
520	Hauptlagerzapfen			1/20
540	Paßlagerzapfen			1/21
550	Hauptlager			1/22
560	Hauptlagerbohrung			1/23
570	Paßlager			1/23
600	Pleuelstange	1/24	-	1/26
710	Nockenwelle	1/27	-	1/28
710	Nockenwelle			1/27
720	Steuerzeiten			1/28
800	Motorschmierung	1/29	-	1/30
800	Schmierölpumpe			1/29
810	Schmieröldruck			1/30
900	Tabelle der Schraubenanzugswerte	1/31	-	1/33

Table of Contents

1. SPECIFICATION DATA		Page	
000	General engine data	1/1	- 1/2
001	Engine weights		1/1
100	Fuel injection system	1/3	- 1/5
110	Fuel injection pump		1/3
120	Governor		1/3
130	Injection nozzle		1/4
140	Commencement of fuel delivery		1/5
200 - 400	Cylinder unit	1/6	- 1/18
200	Cylinder head	1/6	- 1/13
210	Valve guide		1/6
220	Valve seat insert		1/6
230	Valve	1/7	- 1/9
250	Valve spring		1/10
260	Valve clearance		1/11
270	Distances to be checked		1/12
280	Cylinder head studs		1/13
300	Cylinder		1/14
400	Piston	1/15	- 1/16
420	Piston rings	1/17	- 1/18
500 - 700	Motion parts	1/19	- 1/28
500	Crankshaft		1/19
510	Crankpins		1/19
520	Main bearing journals		1/20
540	Thrust bearing journal		1/21
550	Main bearing		1/22
560	Main bearing bore		1/23
570	Thrust bearing		1/23
600	Connecting rod	1/24	- 1/26
700	Camshaft	1/27	- 1/28
710	Camshaft		1/27
720	Valve timing		1/28
800	Lubrication system	1/29	- 1/30
800	Lube oil pump		1/29
810	Oil pressure		1/30
900	Tightening specifications	1/31	- 1/33

Sommaire

1. CARACTERISTIQUES TECHNIQUES		Page	
000	Caractéristiques techniques générales	1/1	- 1/2
001	Poids du moteur		1/1
100	Système d'injection	1/3	- 1/5
110	Pompe d'injection		1/3
120	Régulateur		1/3
130	Injecteur		1/4
140	Début d'injection		1/5
200 - 400	Unité-cylindre	1/6	- 1/18
200	Culasse	1/6	- 1/13
210	Guide de soupape		1/6
220	Siège rapporté de soupape		1/6
230	Soupape	1/7	- 1/9
250	Ressort de soupape		1/10
260	Jeu aux culbuteurs		1/11
270	Distances à contrôler		1/12
280	Vis de culasse		1/13
300	Cylindre		1/14
400	Piston	1/15	- 1/16
420	Segments	1/17	- 1/18
500 - 700	Equipage mobile	1/19	- 1/28
500	Vilebrequin		1/19
510	Manetons		1/19
520	Tourillons		1/20
540	Maneton du palier d'ajustage		1/21
550	Coussinets de ligne d'arbre		1/22
560	Alésage des logements de coussinets		1/23
570	Palier d'ajustage		1/23
600	Bielle	1/24	- 1/26
700	Arbre à cames	1/27	- 1/28
710	Arbre à cames		1/27
720	Calage de la distribution		1/28
800	Lubrification-moteur	1/29	- 1/30
800	Pompe à huile		1/29
810	Pression d'huile		1/30
900	Tableau des valeurs de serrage	1/31	- 1/33

Indice

1. DATOS TECNICOS

Página

000	Datos generales del motor1/1	-	1/2
001	Pesos del motor		1/1
100	Sistema de inyección1/3	-	1/5
110	Bomba de inyección		1/3
120	Regulador		1/3
130	Injector		1/4
140	Comienzo de alimentación		1/5
200 - 400	Unidad de cilindro.....1/6	-	1/18
200	Culata de cilindro.....1/6	-	1/13
210	Guía de válvula		1/6
220	Asiento de válvula		1/6
230	Válvula.....1/7	-	1/9
250	Resorte de válvula		1/10
260	Juego de válvula		1/11
270	Intervalos de control		1/12
280	Tornillos de culuta.....		1/13
300	Cilindro.....		1/14
400	Pistón.....1/15	-	1/16
420	Aros de pistón.....1/17	-	1/18
500 - 700	Tren alternativo1/19	-	1/28
500	Cigüeñal.....		1/19
510	Muñón de manivela.....		1/19
520	Muñón para cojinete de bancada.....		1/20
540	Muñón para cojinete de empuje.....		1/21
550	Cojinete de bancada.....		1/22
560	Alojamiento para cojinete de bancada.....		1/23
570	Cojinete de empuje.....		1/23
600	Biela.....1/24	-	1/26
700	Arbol de levas1/27	-	1/28
710	Arbol de levas.....		1/27
720	Tiempos de distribución.....		1/28
800	Lubricación del motor.....1/29	-	1/30
800	Bomba de aceite lubricante.....		1/29
810	Presión de aceite lubricante.....		1/30
900	Tabla de valores de apriete de tornillos1/31	-	1/33

000 Allgemeine Motordaten
 General engine data
 Fiche signalétique
 Datos generales de los motores

	Deutsch	English	Français	Español
001	Motorgewicht ohne Starter und Generator ca. kg. *	Engine weight w/o starter and generator approx. kg. *	Poids moteur sans démarrreur et génératrice approx. kg. *	Peso motor sin arrancador y generador approx. kg. *
002	Gesamthubvolumen cm ³	Engine swept volume cm ³	Cylindrée totale cm ³	Cilindrada total cm ³
003	Bohrung mm	Bore mm	Alésage mm	Calibre mm
004	Hub mm	Stroke mm	Course mm	Carrera mm
005	Drehrichtung	Direction of rotation	Sens de rotation	Sentido de giro
006	Nennndrehzahl max. 1/min	Rated speed max. rpm	Régime nominal maxi tr/mn	Régimen nom. máx. rpm
007	niedrigste Leerlaufdrehzahl 1/min	Minimum idle speed rpm	Ralenti extrême tr/mn	Régimen mín. en vacío rpm
008	Arbeitsweise	Working cycle	Principe de fonction- nement	Sistema de trabajo

* ca. Gewicht abhängig vom Lieferumfang
 approximate weight dependent on the scope of supply
 poids approximatif, dépend de l' étendue de fourniture
 peso aproximativo, depende del volumen de suministro

	BF6L 513R	BF6L 513RC
001	865	895
002	9572	
003	125	
004	130	
005	Auf Schwungrad gesehen links When facing flywheel left counter-clockwise Vu sur volant à gauche Mirándose sobre el volante izquierda	
006	2300	
007	600 + 50	
008	Viertakt-Diesel Four-stroke diesel Diesel 4 temps Diesel a 4 tiempos	

000 Allgemeine Motordaten
 General engine data
 Fiche signalétique
 Datos generales de los motores

	Deutsch	English	Français	Español
009	Verbrennungs- verfahren	Combustion system	Principe de combustion	Sistema de combustión
010	Verdichtungs- verhältnis	Compression ration	Taux de compression	Relación de compresión
011	Kompressionsdruck bar	Compression pressure bar	Compression bars	Presión en compresión bar
012	Zündfolge	Firing order	Ordre d' allumage	Orden en encendido
020	Abmessungen des Motors mit Schwungrad (normal)	Dimensions of engine incl. standard flywheel	Dimensions du moteur avec volant standard	Dimensiones del motor con volante (normal)
021	größte Länge mm	Max. length mm	Longueur HT mm	Longitud máx. mm
022	größte Breite mm	Max. width mm	Largeur HT mm	Anchura máx. mm
023	größte Höhe mm	Max. height mm	Hauteur HT mm	Antura máx. mm



BF6L 513R/RC

	BF6L 513R	BF6L 513RC
009	Direkteinspritzung Direct injection Injection directe Inyección directa	
010	15,8 : 1	
011	22 - 30	
012	1 - 5 - 3 - 6 - 2 - 4	
020		
021	1533	
022	773	830
023	1130	