

Service Training

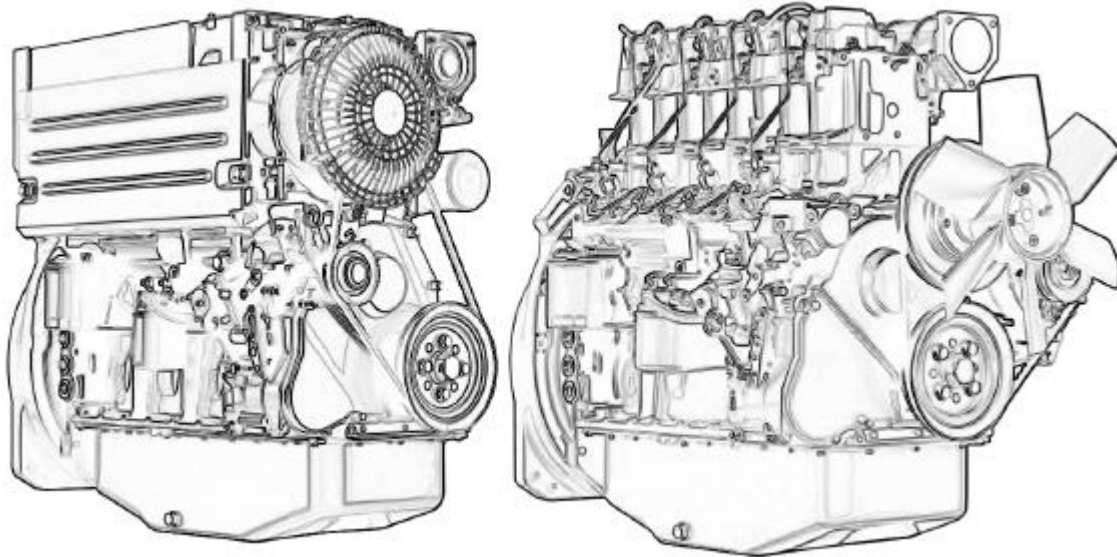

Engine Series DEUTZ 2011



Course-attendant trainee documentation for service training

Product-related engine technology

engine series DEUTZ 2011

Property of:

Attention:

This course attendant trainee documentation is conducive for effective explanation and illustration about the construction and function of engine, components and systems. The contents of figures are only according to the date of printing actual documentation and are not subject to be updated.

Obligatory upon operation, maintenance and repair are only the engineering data and instructions of the actual technical printed material such as operation manuals, workshop manuals, adjusting- and repair-instructions, technical circulars and service bulletins.

Table of contents

Table of contents.....	0-1
1. Engine plan.....	1-1
1.1 Model designation	1-1
1.2 Engine view BFL 2011	1-2
1.3 Engine view BFM 2011	1-4
1.4 Technical data.....	1-6
1.5 Nameplate and engine serial number.....	1-7
1.6 Cylinder numbering.....	1-7
1.7 Description of nameplate.....	1-8
2. Design structure.....	2-1
2.1 Crankcase.....	2-1
2.1.1 Cylinder.....	2-2
2.1.2 Cylinder repair.....	2-2
2.2 Drive system.....	2-3
2.2.1 Connecting rod.....	2-3
2.2.2 Piston	2-4
2.2.3 Determining the piston class (only naturally aspirated engines).....	2-6
2.2.4 Piston cooling.....	2-7
2.2.5 Crankshaft.....	2-8
2.3 Block cylinder head.....	2-10
2.3.1 Valves, valve guidings and valve seat rings.....	2-10
2.3.2 Valve clearance adjustment.....	2-12
2.3.3 Determining the cylinder head gasket	2-14
2.3.4 Mounting the cylinder head	2-16
2.4 Camshaft	2-19
2.5 Setting the control times	2-21
2.5.1 Mounting the toothed belt at unfixed central camshaft screws (basic setting)	2-22
2.5.2 Checking the control times	2-26
2.5.3 Changing the toothed belt at not unfixed central camshaft screw.....	2-27

3. Lube oil – cooling oil system	3-1
3.1 Lube oil – cooling oil circuit	3-1
3.2 Cylinder and cylinder head cooling.....	3-2
3.3 Circuit diagram lube oil – cooling oil circuit	3-4
3.4 Lube oil – cooling oil pump.....	3-6
3.5 Thermostat	3-7
3.6 Valve strip	3-8
4. Fuel system	4-1
4.1 Design structure.....	4-1
4.2 Mounting the injection pump.....	4-2
5. Speed regulator	5-1
5.1 Design structure.....	5-2
5.2 Regulator components.....	5-4
5.2.1 Adaptation.....	5-6
5.2.2 Manifold-pressure compensator (LDA)	5-8

1. Engine plan

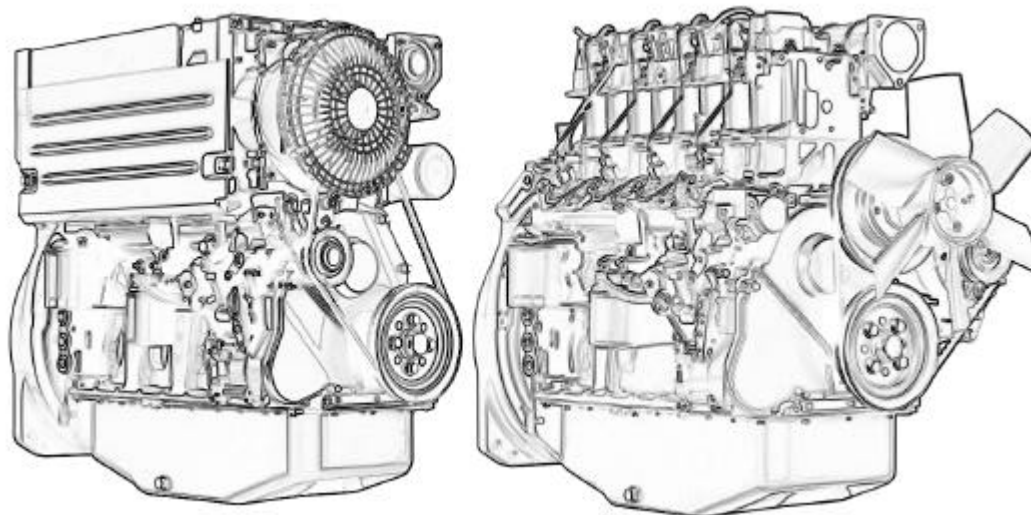

1.1 Model designation

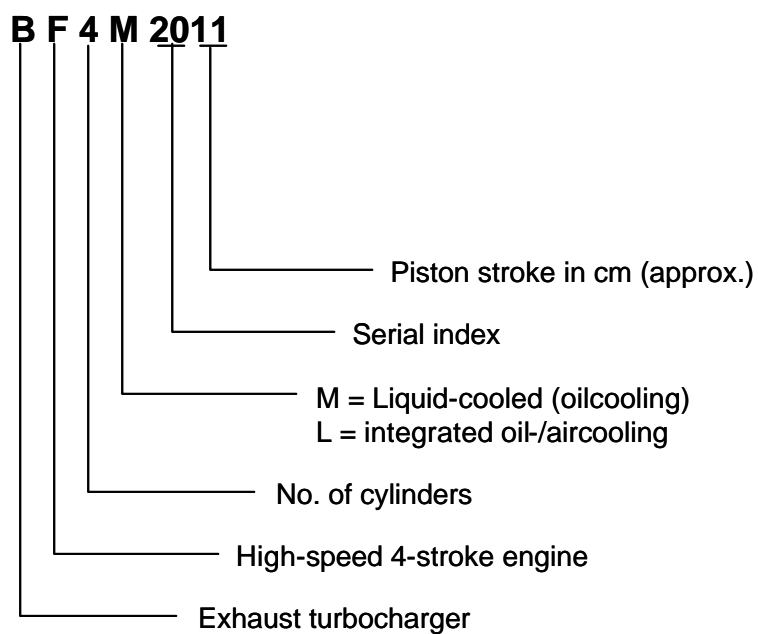

Service-Training

1.2 Engine view DEUTZ BFL 2011

Service side

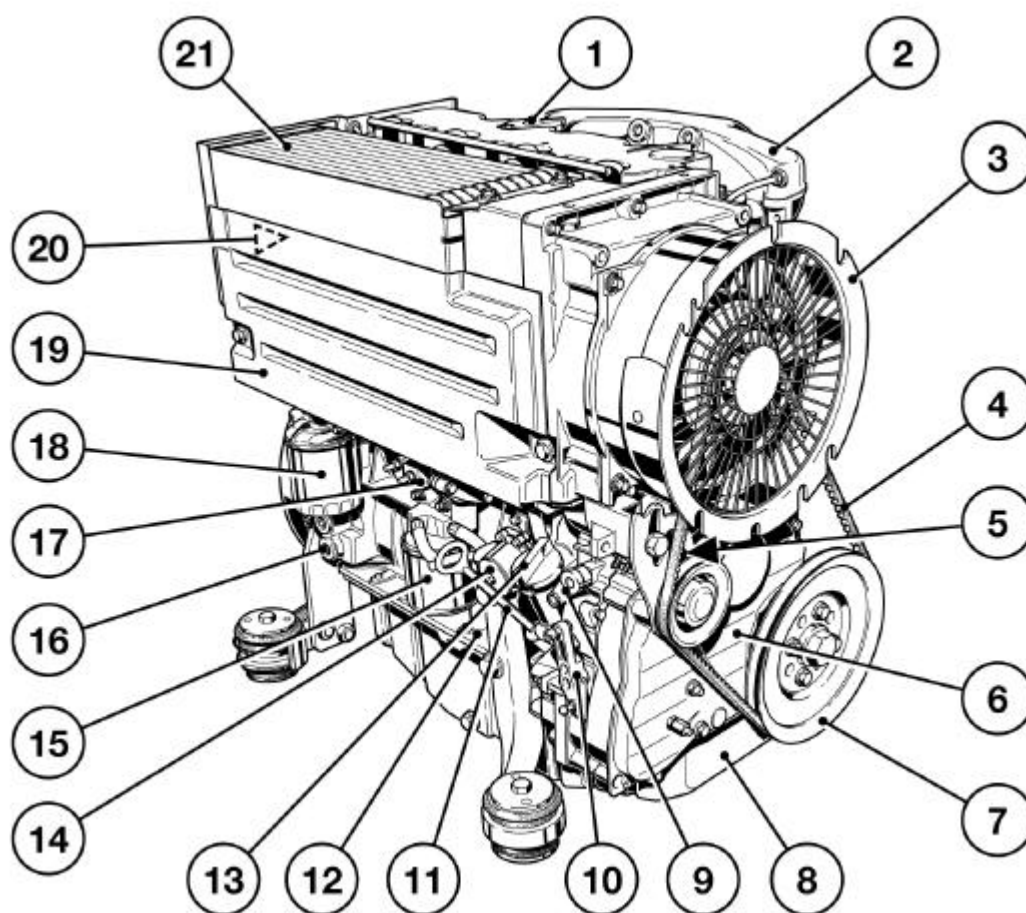

Bild 2011-0001

- | | |
|--|---|
| 1 - Crankcase breathing | 12 - Crankcase |
| 2 - Charge air manifold | 13 - Oil filling socket |
| 3 - Cooling fan with integrated alternator | 14 - Fuel feed pump |
| 4 - V-belt | 15 - Fuel filter |
| 5 - Solenoid (shutdown solenoid) | 16 - Connection for oil heating |
| 6 - Wheel box cover | 17 - Manifold-pressure compensator, LDA |
| 7 - V-belt pulley | 18 - Lube oil filter |
| 8 - Oil pan | 19 - Removable air cowling |
| 9 - Shutdown lever | 20 - Injection pumps |
| 10 - Speed control lever | 21 - Oil cooler |
| 11 - Oil dipstick | |