

WORKSHOP MANUAL

DAIHATSU **CHARADE** Chassis

FOREWORD

This workshop manual contains essential information regarding the construction, disassembly/reassembly procedures and servicing methods of the power train, suspension, brake system, steering system, body and electrical system of the DAIHATSU CHARADE.

We hope that this workshop manual is consulted to the fullest extent, in combination with the workshop manual of the Type CB Engine, Type CL Engine, and Trouble shooting for Engine control system of Type CB-80 Engine so that quality servicing may be assured at all times.

Furthermore, due to continuing improvements in the design, contents and specifications in this workshop manual may be partly revised without advance notice and without incurring any obligation to us.

Published in April, 1987

DAIHATSU MOTOR CO., LTD.

WR-00000



SECTION INDEX

NAME	SECTION
GENERAL INFORMATION	1
CLUTCH	2
MANUAL TRANSMISSION	3
AUTOMATIC TRANSMISSION	4
FRONT AXLE & SUSPENSION	5
REAR AXLE & SUSPENSION	6
STEERING	7
BRAKES	8
BODY	9
BODY ELECTRICAL	10
APPENDIX	11

DAIHATSU

CHARADE

Chassis

SECTION 1

GENERAL INFORMATION

HOW TO READ THIS BOOK	1-2
CONTENTS OF EXPLANATION	1-2
1. Schematic Diagram of Components	1-2
2. Servicing Procedure	1-2
3. Trouble Shooting	1-3
4. Table of SSTs Used	1-3
5. Table of Service Specifications	1-3
6. Table of Tightening Torque	1-3
7. Wiring Diagrams	1-3
DEFINITIONS OF TERMS	1-3
ABBREVIATION CODES	1-4
SERVICING OPERATIONS	1-5
JACKING POINTS AND SUPPORTING	
POINTS OF SAFETY STANDS	1-6
SUPPORTING POINTS OF TWO-POST LIFT	1-6

WR-01001

GENERAL INFORMATION

HOW TO READ THIS BOOK

CONTENTS OF EXPLANATION

1. Schematic Diagram of Components

- (1) The schematic diagram of components that appears at the beginning of each section describes the nomenclature and installed conditions of each component. Furthermore, the tightening torque is posted in the figure.
- (2) Those parts whose reuse is not permitted bear a "★" mark for an identification purpose. Be certain to replace these parts with new ones during the assembly.

(Example)

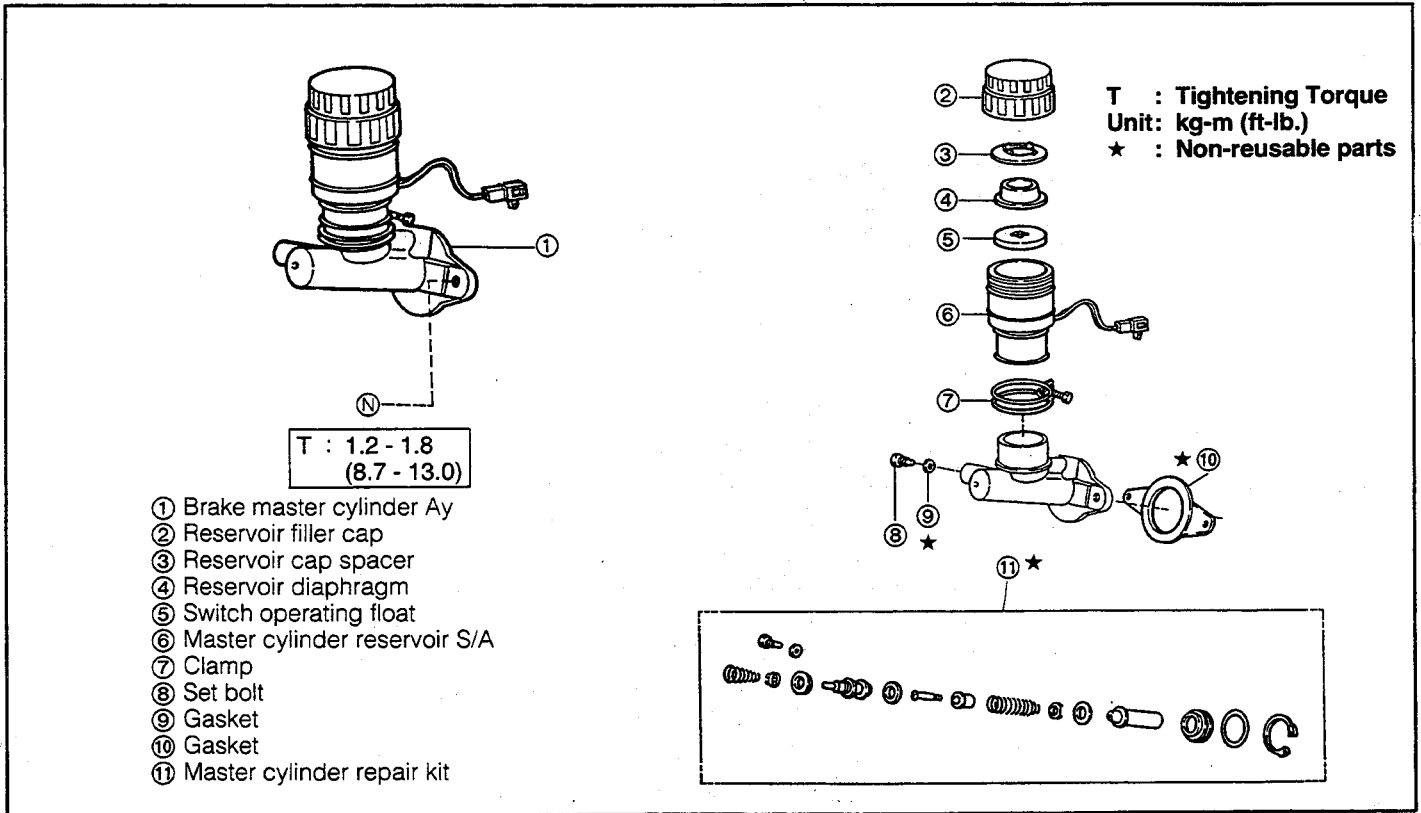

2. Servicing Procedure

- (1) In principle, the servicing procedure is described in the following sequence given below: Removal → Inspection → Installation, and Disassembly → Inspection → Assembly.
- (2) The explanation covers detailed servicing methods, specifications and notes.
- (3) The main point of each item explains the servicing section and servicing procedure, using illustrations.

(Example)

<i>What to do</i>	<i>How to do it</i>
<p>3. Brake tube installation</p> <p>(1) Install the brake tube to the wheel cylinder temporarily by hands.</p> <p>(2) Tighten the brake tube to the wheel cylinder, using the following SST.</p> <p>SST: 09751-36011-000</p>	<div style="border: 1px solid black; padding: 5px;"> <p style="text-align: center;"><i>What to do and where</i></p> <p style="text-align: center;">09751-36011-000</p> </div>

(4) The inspection section in this manual describes only checking operation. Therefore, if you find any malfunction, replace any defective parts with new ones.

3. Trouble Shooting

(1) As for the three-speed automatic transmission, the trouble shooting table is provided in this book so that you may readily locate causes of troubles.

4. Table of SSTs Used

(1) The SSTs appearing in this book are listed in the appendix of the book.

5. Table of Service Specifications

(1) The service specifications necessary for the service are summarized in the appendix of this book.

6. Table of Tightening Torque

(1) As for those sections where their tightening torque must be controlled during the service, the tightening torque is specified in the appendix of this book.

7. Wiring Diagrams

(1) The vehicle wiring diagrams are posted in the appendix of this book separately for Type CB and Type CL engines.

DEFINITIONS OF TERMS

Specified Value A value which represents the allowable range during the inspection and adjustment.

Limit A maximum or a minimum limit which the value should not exceed or fall below.

Note An item which requires special attention or an item which is prohibited during the service.

WR-01004

GENERAL INFORMATION

ABBREVIATION CODES

The abbreviation codes that appear in this workshop manual stand for the following, respectively.

Abbreviation code	Original word	Meaning
RH	Right Hand	Refers to right side.
R.H.D.	Right-Hand Drive	Right hand drive vehicle.
LH	Left Hand	Refers to left side.
L.H.D.	Left-Hand Drive	Left-hand drive vehicle.
STD	Standard	When referring to automotive parts, "standard" represents those parts which have been installed originally by the manufacturer and which have standard dimensions.
O/S	Over Size	In instances where fitting becomes too loose due to wear resulting from use for a long period of time or due to frequent removal/installation operations, if fitting part (e.g. piston) is replaced with a part having larger dimensions, the other mating part may be put into use again. "Over sized" parts denote those parts having larger dimensions compared standard parts.
U/S	Under Size	In the same manner as with the "oversized" parts, if fitting part (e.g. bush and bearing) is replaced with a part having smaller bore dimensions, the other mating part may be put into use again. "Under sized" parts denote those parts having smaller dimensions compared with standard parts.
PR	Ply Rating	Represents strength of tires. The larger the ply rating number, the stronger the tire strength.
SAE	Society of Automotive Engineers	For example, automotive oils are designated as SAE so and so number. These designation numbers have been set forth by the Society of Automotive Engineers in the United States of America (SAE). The larger the SAE number, the higher the oil viscosity. Conversely, the smaller the SAE number, the lower the oil viscosity.
API	American Petroleum Institute	The standards set forth by the American Petroleum Institute (abbreviated as API Classification) have been employed to evaluate and classify properties of various oils. Engine oils for gasoline engines are classified as SD, SE, SF and so on, whereas engine oils for diesel engines are classified as CC, CD and so on.
SST	Special Service Tool	Refers to a tool designed for a specific purpose.
T	Torque	Refers to tightening torque.
S/A	Sub-Assembly	Refers to a component comprising more than two single parts which are welded, staked, or studded to each other to form a single component.
Ay	Assembly	Refers to an assembled component comprising more than two single parts or sub-assembly parts.
W/	With	Denotes that the following part is attached.
L/	Less	Denotes that the following part is not attached.
M/T	Manual Transmission	Refers to manual transmission.
A/T	Automatic Transmission	Refers to automatic transmission
ISO	International Organization for Standardization	The standards set forth by the international Organization for Standardization (abbreviated as ISO classification) have been employed to evaluate and classify properties of various component parts and oils etc.

The abbreviation codes that appear in the figure stand for the following, respectively.

ⓑ	Bolt	Ⓢ	Screw
Ⓝ	Nut	Ⓦ	Washer

WR-01005

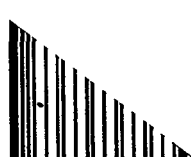

SERVICING OPERATIONS

1. Jacking up

- (1) When only the front section or rear section of the vehicle is jacked up, be sure to place chocks at the wheels so as to insure safe operations.
- (2) When the vehicle has been jacked up, be sure to support the vehicle at the specified sections using safety stands.

2. In the case of repairs on the electrical system or the removal/installation of the engine, first disconnect the negative \ominus terminal of the battery. Then, proceed to the operations. (On clock-equipped vehicles, set the time of the clock after the negative \ominus terminal of the battery is connected.)

3. Repairing fuel system of Type CB-80 engine

Type CB-80 engine employs a high fuel pressure. Therefore, the following notes should be observed.

- (1) When the union bolt is removed, take a measure to prevent the fuel from splashing with a cloth or the like. Slacken the union bolt gradually.
- (2) Tighten each connecting section to the specified torque.
- (3) Attach the specified clip to each connecting section.

4. For increased work efficiency and improved accuracy, be sure to utilize the SSTs (Special Service Tools) effectively.

5. Removal and disassembly

- (1) When disassembling complicated components, put stamped marks or mating marks on those sections where such marks do not affect their functions so that the assembling operation may be performed easily.
- (2) Each time a part is removed, check the part for the assembled condition, deformation, breakage, roughness and scratches.
- (3) Arrange the disassembled parts in the disassembling order. In addition, separate and arrange those parts to be replaced and those parts to be reused.
- (4) Thoroughly clean and wash those parts to be reused.
- (5) Inspection and measurement of part
Perform thorough inspection and measurement on those parts to be reused, as required.

6. Installation and assembly

- (1) Assemble those satisfactory parts, following the proper procedure and specified standards (adjusting values and tightening torque, etc.).
- (2) Ensure that seal packings and grease are applied to those sections where such application is needed.
- (3) Be sure to use new packings, gaskets, cotter pins and so forth.
- (4) Ensure that the specified bolts and nuts only be used. Moreover, where specified, make sure to employ a torque wrench to tighten bolts and nuts to the specified torque.
Make sure to use only genuine parts for every replacement.

7. Adjustment and operation check

Adjust the reassembled or replaced components to the servicing specifications, using gauges and testers, as required.

8. Handling of hose, etc.

- (1) Connect fuel hoses and water hoses, etc. securely so that they exhibit no leakage.
- (2) When disconnecting fuel hoses, make sure that no fuel is splashed around the hose. (Special care must be exercised as to the engine mount rubber, etc., for there is a possibility that the rubber is deteriorated by the petrol-based liquid.)

GENERAL INFORMATION

9. Touch-up painting

If paint finish surfaces of the body and bolts should be scratched when bolts, etc. are removed during the body alignment, etc., touch up the scratch with a paint having the same color as that of the body.

WR-01006

JACKING POINTS AND SUPPORTING POINTS OF SAFETY STANDS

• Jacking point

Front side Engine mounting center member (Place the jack below the member, exercising care of the exhaust pipe.)

Rear side Center of rear floor cross member

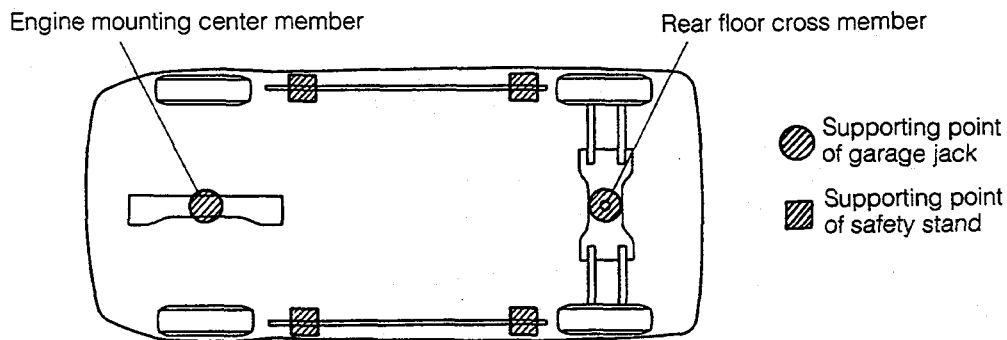

• Supporting points of safety stands

Four supporting points are located at the right and left sides. (The supporting points have been strengthened by spot-welding reinforcements. Never support the vehicle at points other than the specified points.)

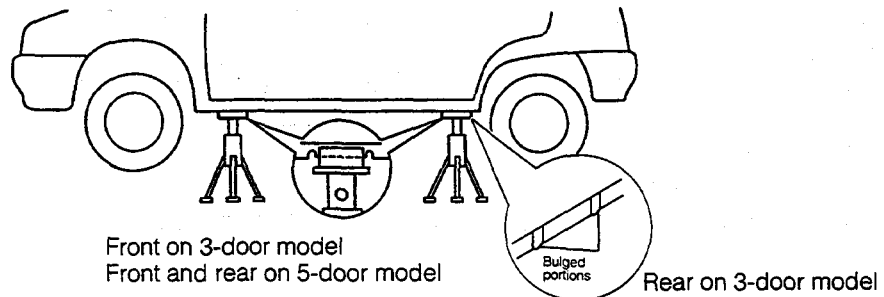

Fig. 1-1

WR-01007

SUPPORTING POINTS OF TWO-POST LIFT

Align the supporting pads of a two-post lift with the supporting points of safety stands, as indicated in the figure above.

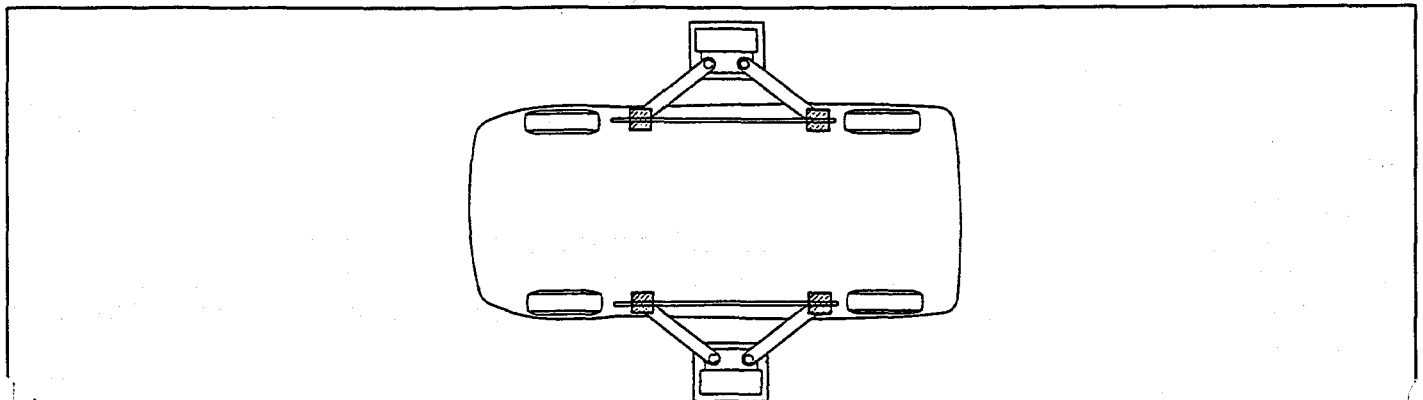

Fig. 1-2

WR-01008

DAIHATSU

CHARADE

Chassis

2

SECTION 2

CLUTCH

DESCRIPTION	2- 2
TROUBLE SHOOTING	2- 2
CLUTCH PEDAL ADJUSTMENT	2- 2
CLUTCH PEDAL AND	
CLUTCH RELEASE CABLE	2- 4
COMPONENTS	2- 4
REMOVAL	2- 4
INSPECTION	2- 5
INSTALLATION	2- 6
CLUTCH UNIT	2- 7
COMPONENTS	2- 7
REMOVAL	2- 7
INSPECTION	2- 8
INSTALLATION	2-10

WR-02001

CLUTCH

DESCRIPTION

TROUBLE SHOOTING

Symptom	Possible causes	Remedies	Page
Gear shifting is hard or impossible.	<ul style="list-style-type: none"> Excessive clutch pedal free travel. Excessive clutch disc runout, or damaged lining. Input shaft or disc splined section contaminated or sticking. Faulty clutch pressure plate. 	<ul style="list-style-type: none"> Adjust clutch pedal free travel. Check clutch disc. 	2-3
		<ul style="list-style-type: none"> Repair, as required. 	2-8
		<ul style="list-style-type: none"> Replace clutch cover. 	2-8
Slipping clutch	<ul style="list-style-type: none"> Improper clutch pedal free travel. Worn or oily clutch disc linings. Faulty pressure plate. Flattened diaphragm spring. 	<ul style="list-style-type: none"> Adjust clutch pedal free travel. Replace clutch disc. Replace clutch cover. Replace clutch cover. 	2-3 2-7 2-7 2-7
		<ul style="list-style-type: none"> Check clutch disc and replace, as required. Replace clutch cover. Replace clutch disc. Replace clutch cover. 	2-8 2-7 2-7 2-7
Grabbing and chattering clutch	<ul style="list-style-type: none"> Worn or oily clutch disc linings. Faulty pressure plate. Flattened disc torsion spring. Bent diaphragm spring. 	<ul style="list-style-type: none"> Repair, as required. Replace release bearing. 	2-7
		<ul style="list-style-type: none"> Repair, as required. 	2-7
Clutch noises	<ul style="list-style-type: none"> Parts in housing loose. Worn or contaminated release bearing. Release fork and linkage seized. 	<ul style="list-style-type: none"> Adjust clutch pedal free travel. Replace clutch cover. 	2-3 2-7
		<ul style="list-style-type: none"> Replace clutch cover. 	2-7

WR-02002

CLUTCH PEDAL ADJUSTMENT

- Check the clutch pedal for the installation height.
Pedal installation height
(Distance between pedal pad upper surface's center and dash panel)
 - R.H.D. vehicle 189.5 - 194.5 mm (7.46 - 7.66 inch)
 - L.H.D. vehicle 181.5 - 186.5 mm (7.15 - 7.34 inch)
- Adjust the pedal installation height, as required.
 - Slacken the lock nut. Turn the stopper bolt until the installation height conforms to the specification.
 - Tighten the lock nut.

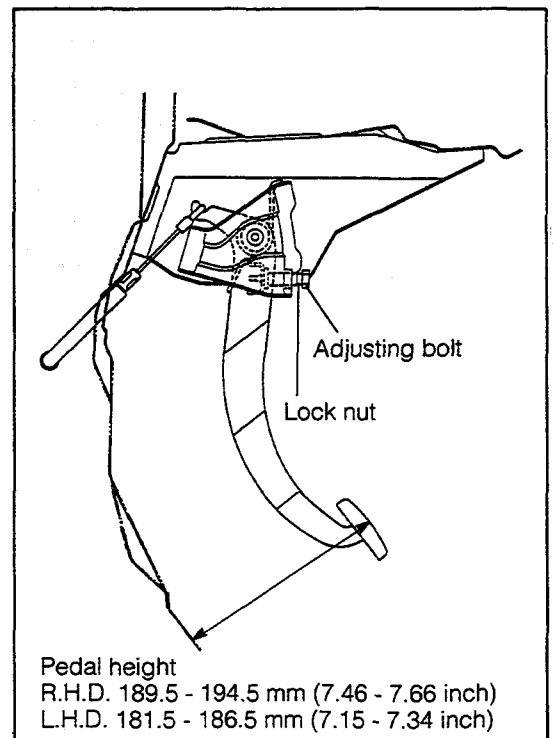

Fig. 2-1

WR-02003

3. Clutch cable adjustment

- (1) Pull the outer cable lightly with a force of 2 - 5 kg (4.4 - 11.0 lb). Check the clearance.
- (2) Ensure that the stopper (protruding portion) is fitted securely in the adjusting groove.
- (3) Adjusting position of clutch outer cable
3 - 6 mm (0.12 - 0.24 inch)

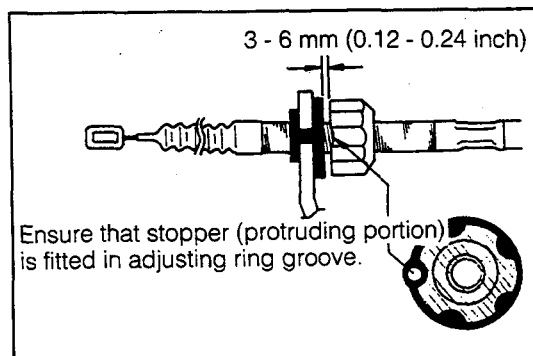

Fig. 2-2

WR-02004

4. Adjust the clutch pedal free travel.

- (1) Depress the clutch pedal gradually until you feel a resistance from the clutch. Measure the depressing distance up to this point.

Pedal Free Travel: 15 - 30 mm (0.59 - 1.18 inch)

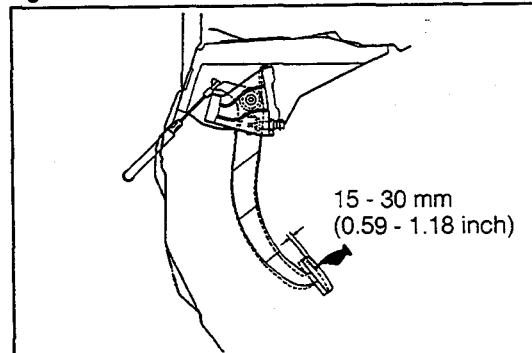

Fig. 2-3

WR-02005

5. Adjust the clearance between the clutch pedal and the floor with the pedal fully depressed. (Minimum clearance between the dash panel and the pedal arm)

Vehicles mounted with Type CB-80 engine:

not less than 20 mm (0.79 inch)

Vehicle other than those mounted with Type CB-80

engine: not less than 25 mm (0.98 inch)

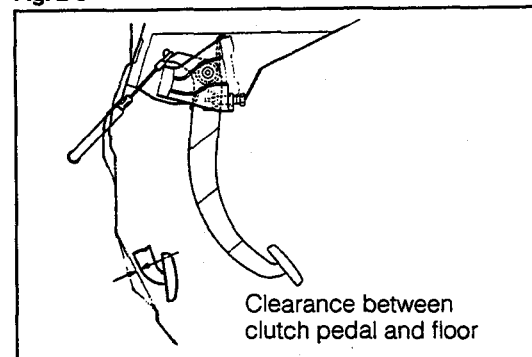

Fig. 2-4

WR-02006

CLUTCH

CLUTCH PEDAL AND CLUTCH RELEASE CABLE COMPONENTS

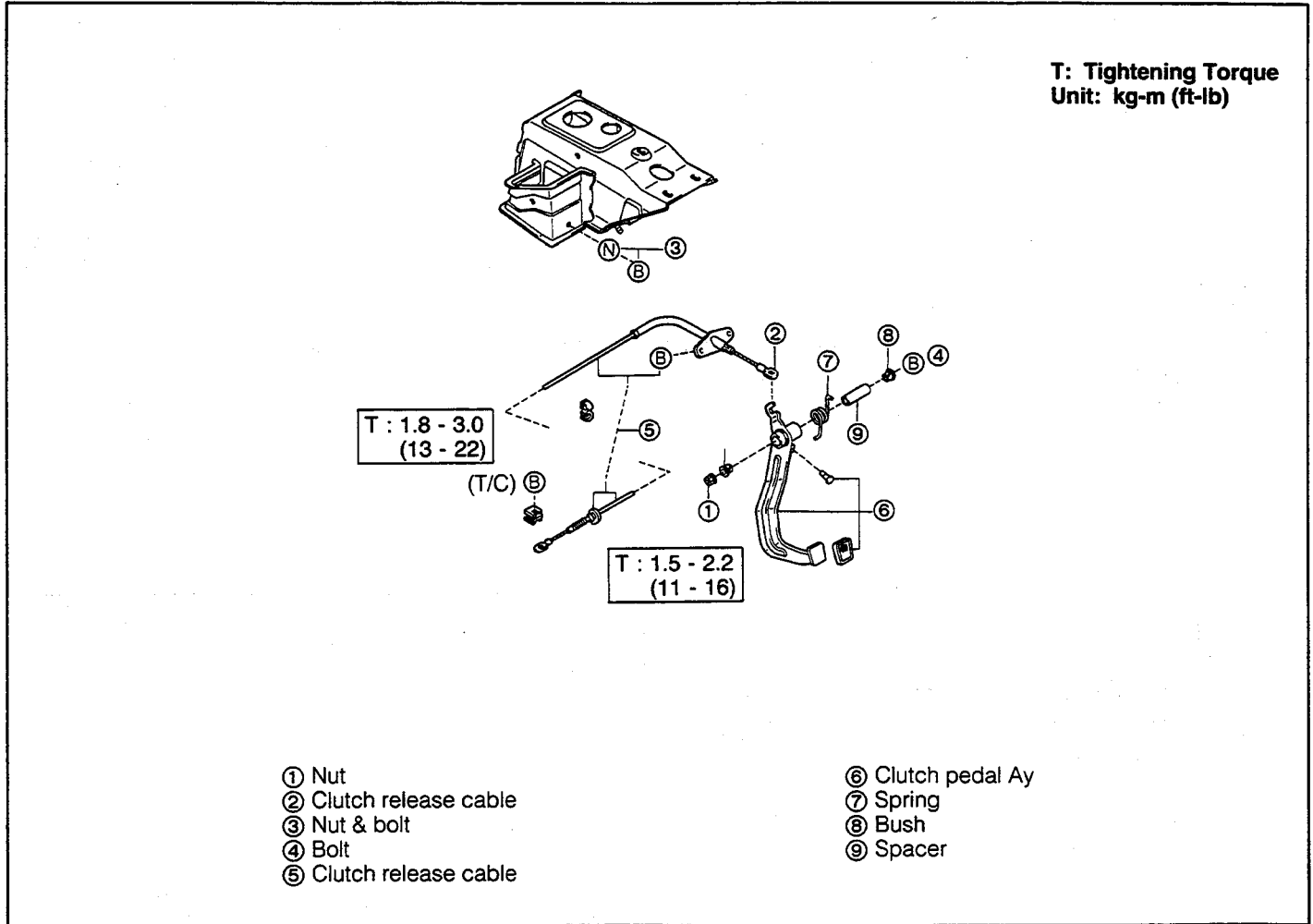

Fig. 2-5

WR-02007

REMOVAL

1. Remove the brake pedal Ay. (Only for L.H.D. vehicles. See page 8-7)
2. Remove the nut located at the clutch pedal installation section. Separate the end section of the clutch release cable.
3. Remove the adjusting bolt.

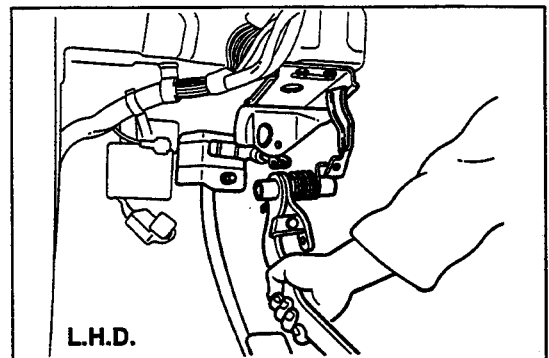

Fig. 2-6

WR-02008

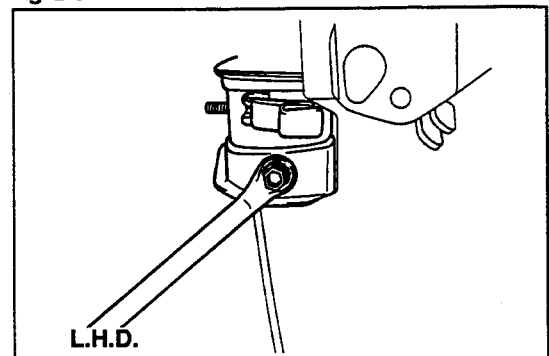

Fig. 2-7

WR-02009

4. Remove the bolt with washer.

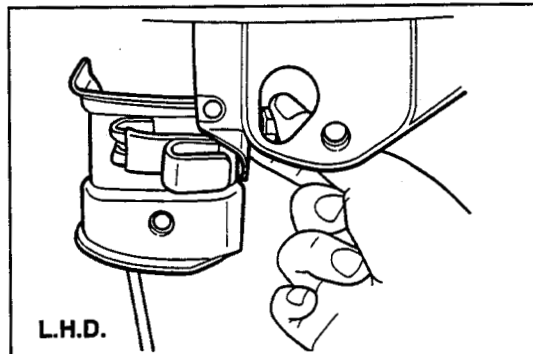

Fig. 2-8

WR-02010

5. Remove the cable bracket attaching bolt. Remove the clutch cable.

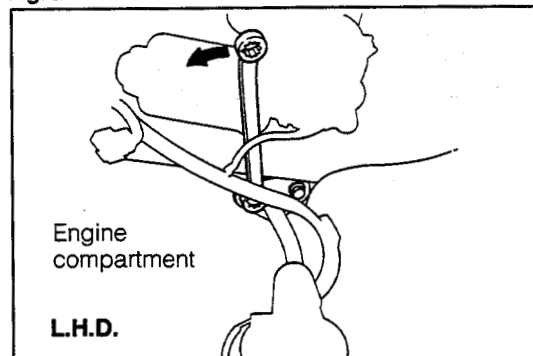

Fig. 2-9

WR-02011

6. Remove the clutch pedal assembly. Remove the spring, bush and spacer.

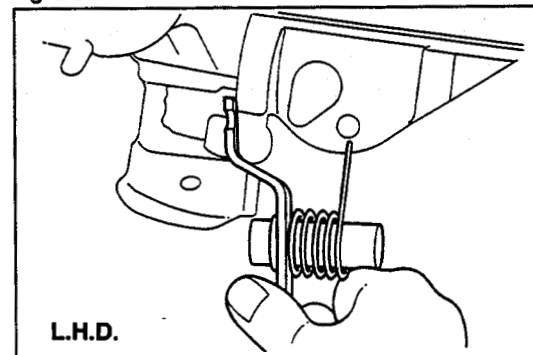

Fig. 2-10

WR-02012

INSPECTION

Inspect the following parts.

1. Bush for wear or damage.
2. Pedal spacer for wear or damage.
3. Pedal for damage or deformation.
4. Pedal pad for wear or damage.
5. Spring for flattened condition.

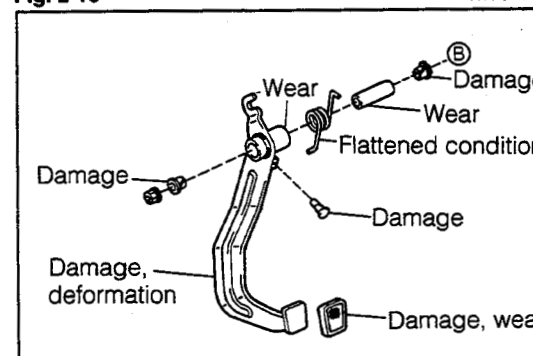

Fig. 2-11

WR-02013

6. Each section of clutch cable

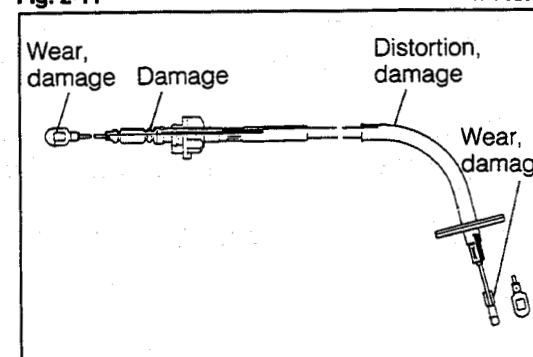

Fig. 2-12

WR-02014

CLUTCH

INSTALLATION

1. Apply MP grease to the following points.
 - (1) Inside of bush and spacer
 - (2) Connecting section of clutch pedal and release cable
2. Install the spring, bush and spacer to the clutch pedal assembly. Then, install the assembly to the pedal bracket.
3. Install the bolt with washer in position.
4. Install both ends of the clutch cable. Tighten the bracket with the bolts.

Tightening Torque: 0.4 - 0.7 kg-m (2.9 - 5.1 lb)
5. Install the adjusting bolt.
6. Tighten the nut.

Tightening Torque: 1.5 - 2.2 kg-m (11 - 16 lb)
7. Depress the clutch pedal two or three times. Proceed to adjust the clutch pedal, following the procedure at page 2-2.
8. Install the brake pedal Ay. (Only for L.H.D. vehicles. See page 8-8)

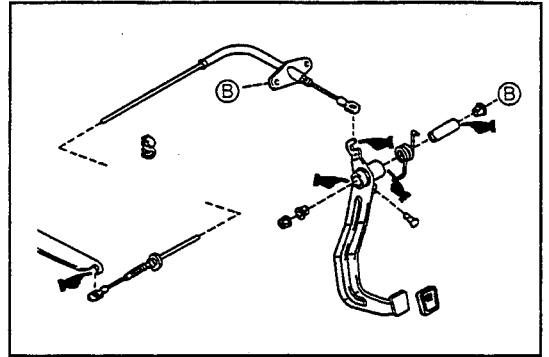

Fig. 2-13

WR-02015

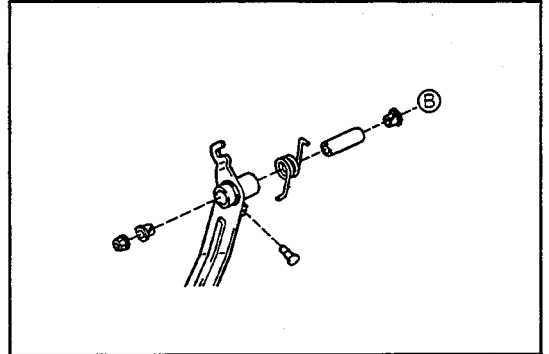

Fig. 2-14

WR-02016

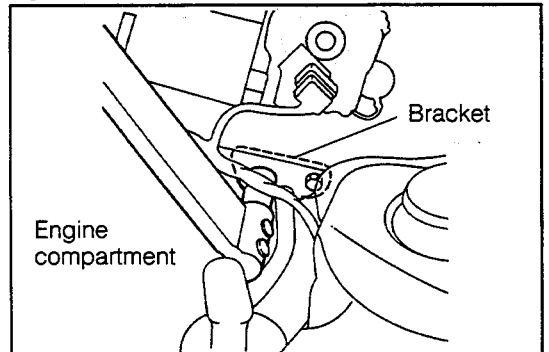

Fig. 2-15

WR-02017

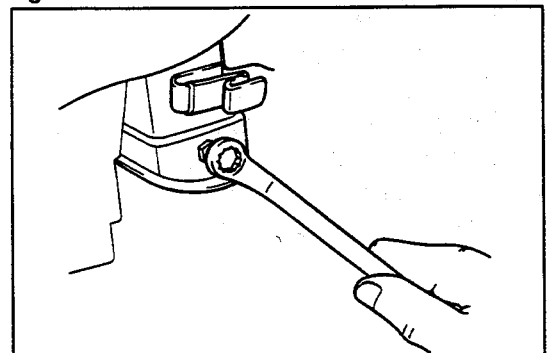

Fig. 2-16

WR-02018

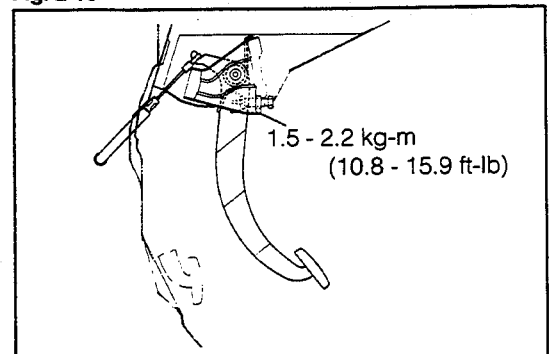
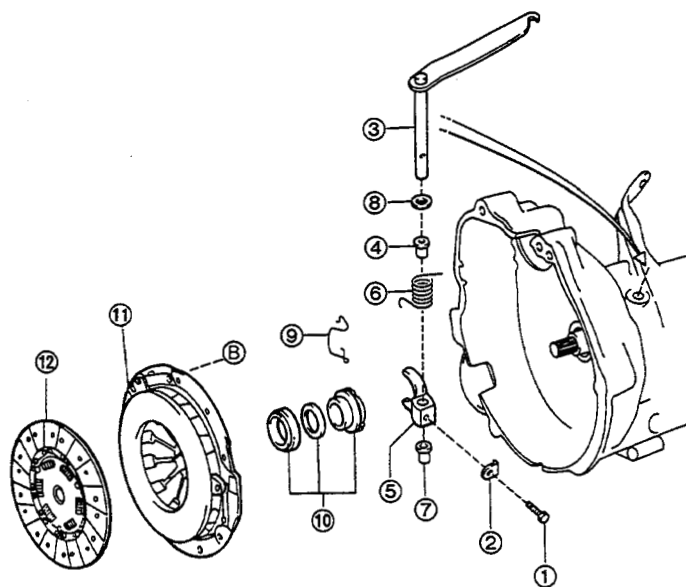

Fig. 2-17

WR-02019



**CLUTCH UNIT
COMPONENTS**



- ① W/Washer bolt
- ② Lock plate
- ③ Clutch release fork lever
- ④ Bush No. 1
- ⑤ Clutch release lever yoke
- ⑥ Torsion spring

- ⑦ Bush No. 1
- ⑧ Dust seal
- ⑨ Release bearing clip
- ⑩ Clutch release bearing hub
- ⑪ Clutch cover
- ⑫ Clutch disc

Fig. 2-18

WR-02020

REMOVAL

1. Remove the transmission assembly from the vehicle. (See page 3-3.)

**SEE
TRANSMISSION
REMOVAL SECTION
Page 3-3 to 3-7.**

2. Release the lock plate. Proceed to remove the lock plate along with the bolt.

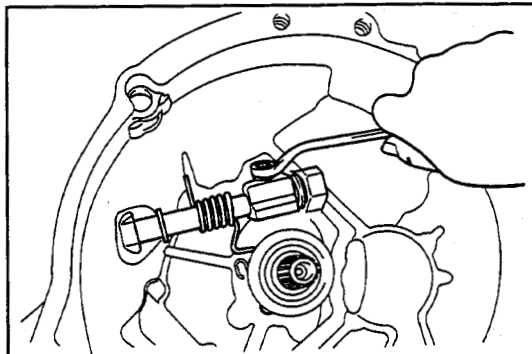

Fig. 2-19

WR-02022

CLUTCH

3. Pull out the clutch release fork lever. Remove the bush, release lever yoke, spring, release bearing clip and release bearing hub.

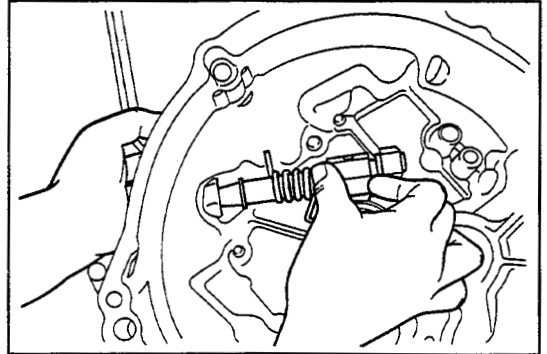

Fig. 2-20

WR-02023

4. Remove the clutch cover from the flywheel. Take out the clutch disc.

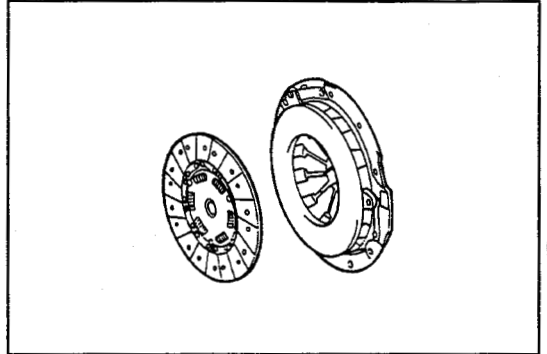

Fig. 2-21

WR-02024

INSPECTION

1. Check the pressure plate and flywheel surface for scores, cracks and discoloration.

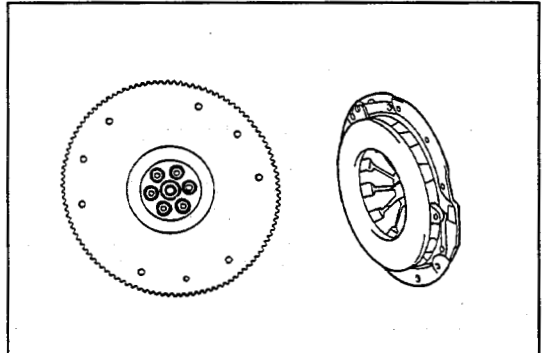

Fig. 2-22

WR-02025

2. Check the diaphragm spring tips for wear, rust and breakage.

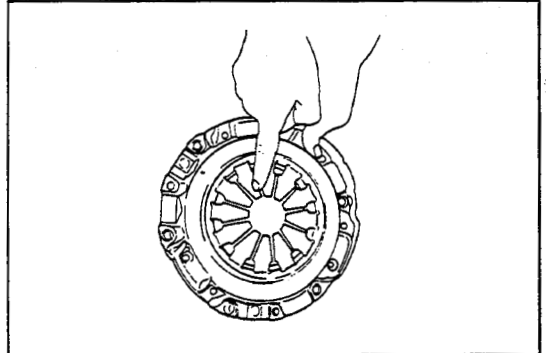

Fig. 2-23

WR-02026

3. Check the clutch disc for wear and runout.
Allowable Wear Limit (Rivet Depth):
0.3 mm (0.012 inch)

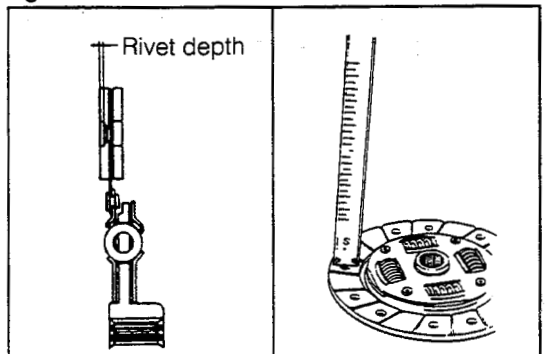
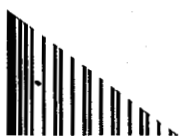

Fig. 2-24

WR-02027



Allowable Limit of Lateral Runout:
1.34 mm (0.0528 inch)

NOTE:

Measure the lateral runout with the clutch disc assembled onto a new input shaft.

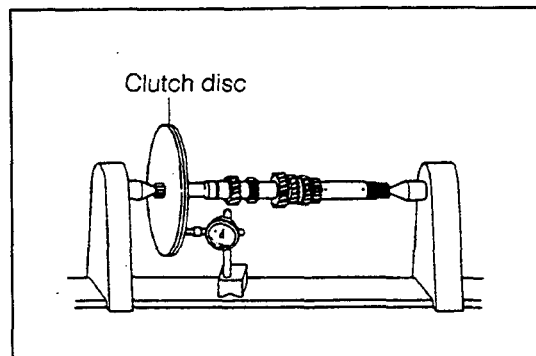

Fig. 2-25

WR-02028

4. Check to see if the release bearing rotates smoothly. Rotate the release bearing by your hand, while applying a pressure to the bearing in a thrust direction. Check to see if the bearing rotates without any abnormal feeling or binding.

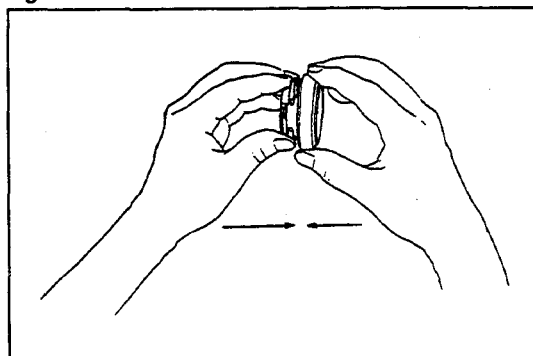

Fig. 2-26

WR-02029

5. Check the release bearing hub, clip-contacting surface and hub-to-housing sliding section for damage and wear.

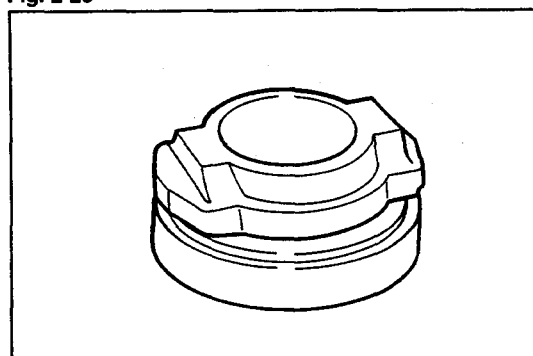

Fig. 2-27

WR-02030

6. Check to see if the clip has the configuration as shown in the figure in its horizontal plane.

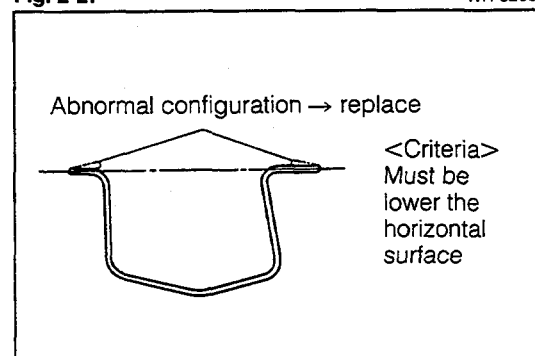

Fig. 2-28

WR-02031

CLUTCH

INSTALLATION

1. Install the clutch disc and clutch cover, using the following SST.

SST: 09301-87202-000

Bolt Tightening Torque: 1.5 - 2.2 kg-m (11 - 16 ft-lb)

NOTE:

- (1) Assemble the clutch disc in the direction as shown in the figure.
 - (2) Tighten the bolts evenly, starting with those bolts provided near the locating pin.
 - (3) Apply long-life chassis grease to the clutch disc splined section.
2. Check the clutch cover diaphragm spring tips for variation in height. Adjust the diaphragm spring tips, as required.

Check

Allowable Limit of Variation in Height:

0.7 mm (0.028 inch)

SST: 09302-87701-000

87702

Adjustment

Align the diaphragm spring tips at such a height that makes the number of tips to be adjusted at a minimum number.

SST: 09333-00011-000

3. Assemble the clutch release bearing hub and release bearing clip to the clutch release lever yoke.
 - (1) Bring the cut-out section of the release lever yoke in contact with the clip.
 - (2) Under the condition described in (1), assemble the lever yoke by turning it 180 degrees.

NOTE:

Apply long-life chassis grease to the yoke-to-hub sliding section and bearing-to-housing case sliding section.

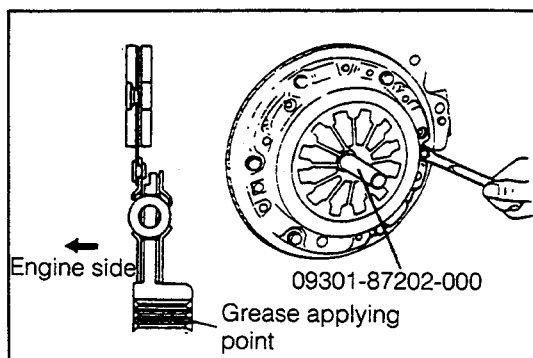

Fig. 2-29

WR-02032

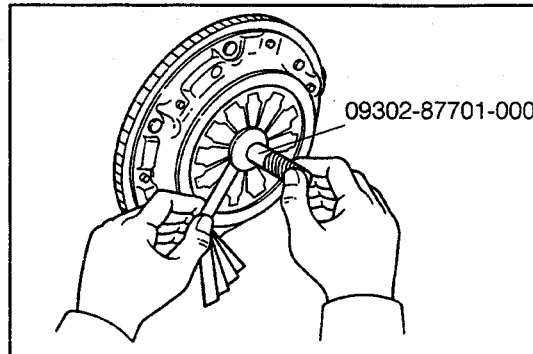

Fig. 2-30

WR-02032A

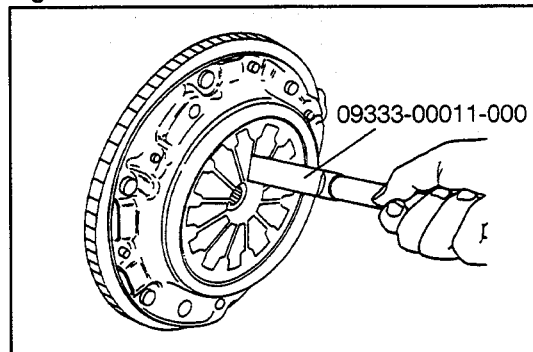

Fig. 2-31

WR-02033

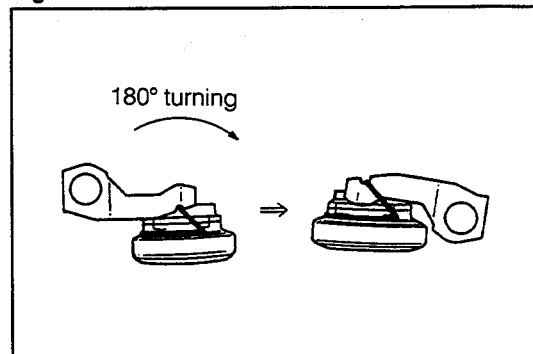

Fig. 2-32

WR-02034

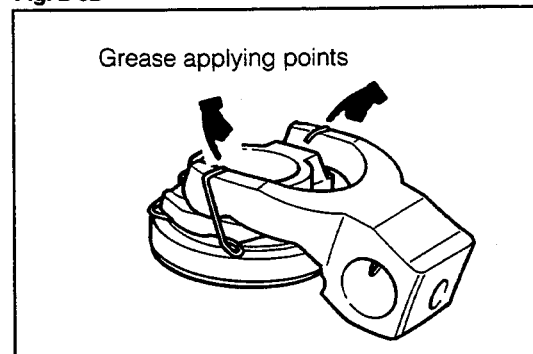

Fig. 2-33

WR-02035