

Cummins Shop Manual C Series Engines

Full download: <http://manualplace.com/download/cummins-shop-manual-c-series-engines/>

C Series Shop Manual

– Foreword –

This manual provides instructions for complete rebuild of the "C" Series Engine. This version of the manual was written for Models 6C8.3, 6CT8.3 and 6CTA8.3.

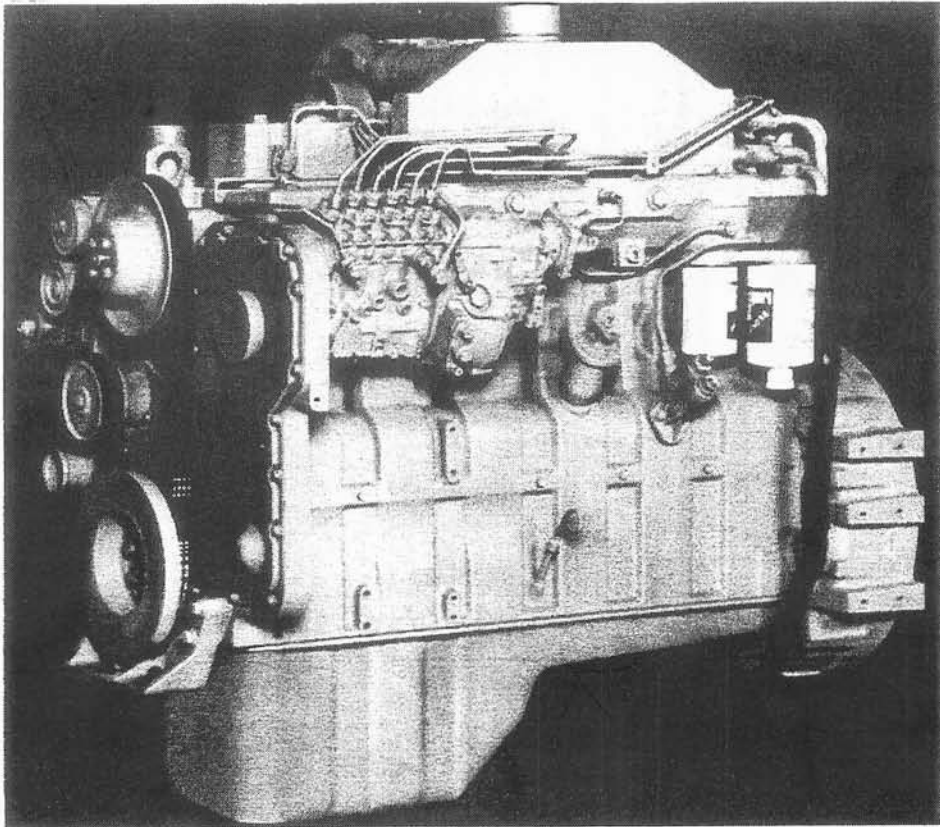

The content of this manual is based on the most current information at the time of publication approval and is subject to change without notice.

Cummins Small Engine C Series

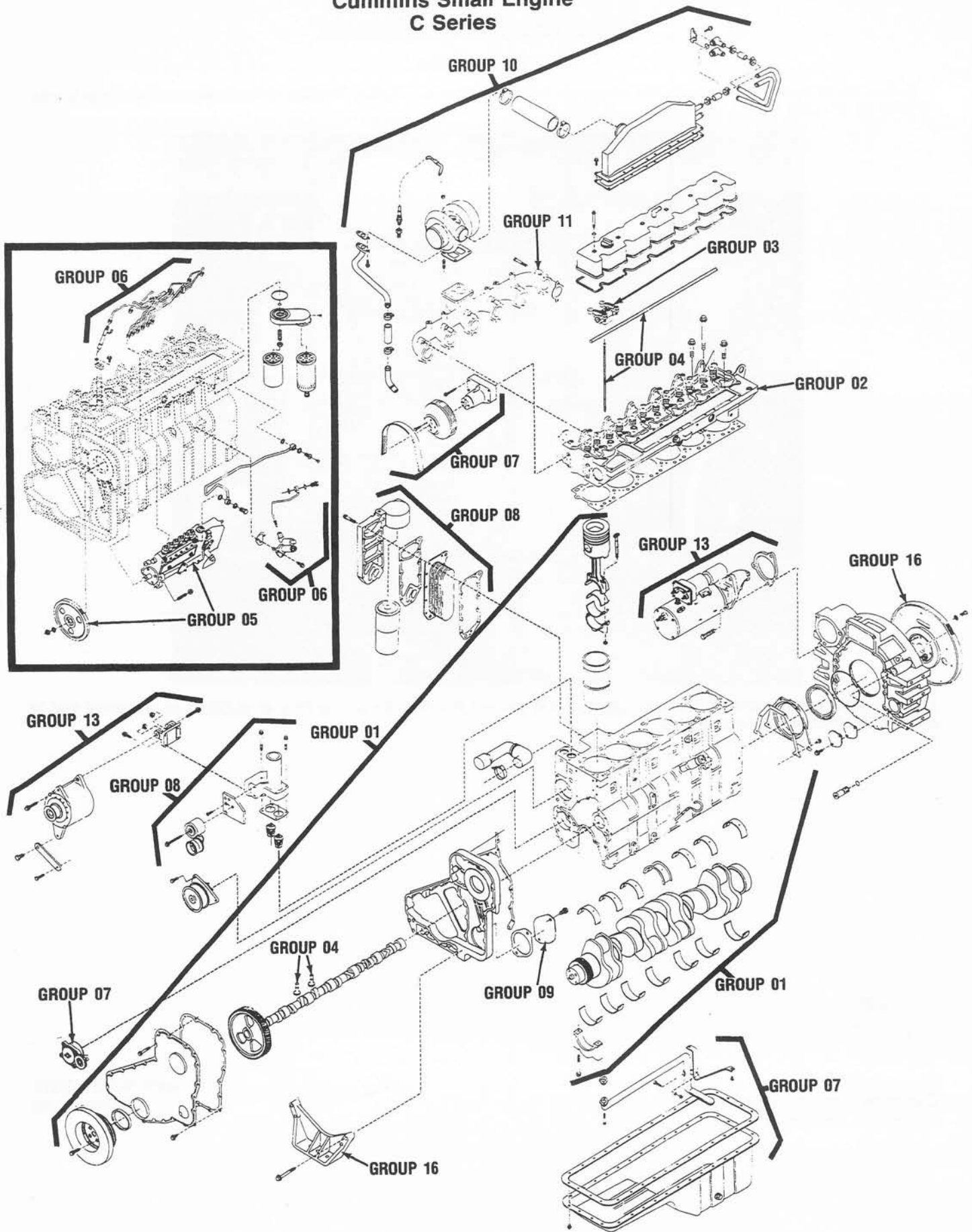

Shop Manual

Table of Contents

	Page
Introduction	i-5
Group 0 - Engine Disassembly and Assembly	0-1
Group 1 - Cylinder Block	1-1
Group 2 - Cylinder Head	2-1
Group 3 - Rocker Levers	3-1
Group 4 - Tappets and Push Rods.....	4-1
Group 5 - Fuel System	5-1
Group 6 - Injectors and Fuel Lines	6-1
Group 7 - Lubricating System	7-1
Group 8 - Cooling System.....	8-1
Group 9 - Drive Units	9-1
Group 10 - Air Intake System	10-1
Group 11 - Exhaust System.....	11-1
Group 12 - Air Equipment	12-1
Group 13 - Electrical Equipment.....	13-1
Group 14 - Engine Testing	14-1
Group 16 - Mounting Adaptations	16-1

Introduction

Table of Contents

	Page
Abbreviations Used in this Manual	i-25
About the Manual	i-6
Capscrew Markings and Torque Values - Metric	i-19
C Series Lubricants	i-24
C Series Sealants	i-23
C Series Torque Specifications.....	i-20
Engine Data Plate	i-15
External Engine Components.....	i-17
Fuel Pump Data Plate (Name Plate)	i-16
General Cleaning Instructions	i-26
• Solvent and Acid	
• Steam	
General Rebuild Instructions.....	i-7
General Safety Instructions	i-8
General Torque Specifications.....	i-19
Generic Symbols	i-10
How to Identify Your Engine	i-15
Illustrations	i-14
Tools Required to Rebuild the C Series Engine.....	i-27

About the Manual

The procedures in this manual were developed for a shop environment with engine disassembly and assembly being performed on a rollover stand. A Group System has been used to subdivide the instructions by major components and systems. Refer to the Table of Contents (page i-3) for the various groups. The information is presented in very basic terms to make sure the instructions are easily understood. Wrench sizes and shop tooling are identified in the procedure when needed.

Each group contains the following in sequence:

- An Alphabetical Table of Contents (Index).
- Exploded view(s) of all the components in the group.
- General Information Section(s) containing the basic service, maintenance, and design information necessary to assist in the rebuild of the engine or a component.
- Procedural instructions for the disassembly, inspection, repair, and assembly that can be required to rebuild an engine. Additional repairs that are not essential during every rebuild, but can be necessary, are included. These repairs depend on the length of time an engine has been in service and the condition of the parts.

General Rebuild Instructions

The C Series Engine incorporates the latest diesel technology, yet it is designed to be rebuilt using existing repair practices performed to quality standards.

Observe all of the safety precautions noted in the procedures.

Provide a clean environment and follow the cleaning instructions specified in the procedures.

Cleanliness is an important consideration during repair of a diesel engine. Built-in contamination can reduce the life of an engine.

Perform the inspections specified in the procedures.

Replacement of worn and damaged parts is also necessary for a successful rebuild - the engine cannot be better than its components.

The dimensions given for a part such as a cylinder bore include the minimum dimension of a new part and the maximum dimension of a part that can be reused. The dimensions of a part such as a crankshaft include the maximum dimension of a new part and the minimum dimension of a part that can be reused. Replace or recondition the parts worn beyond the limits given.

Use genuine Cummins new or ReCon® service parts and assemblies.

The assembly instructions have been written for reusing as many parts and assemblies as is practical. When it is necessary to replace a part or assembly, the procedure is based on the use of new or ReCon® parts. However, some of the major components such as the cylinder block and head can be restored to usable condition by machining. Refer to the Alternative Repair Manual or contact your nearest Cummins Distributor for the correct procedures. All of the rebuild service described in this manual is available from all Cummins Distributors and many Dealer locations.

Follow the specified disassembly and assembly procedures to avoid damaging the parts and to ensure the components are properly assembled and tightened.

In-chassis repair instructions are available in the Troubleshooting and Repair Manual Bulletin Number 3810261, which can be ordered or purchased from a local Cummins Distributor.

The contents of this manual are based on information in effect at the time of publications approval and are subject to change without notice.

Comply with the manufacturer's recommendations for cleaning solvents and other substances used in connection with the rebuild of the engine. Also, observe good safety practices regarding the use of tools and machines.

General Safety Instructions

Important Safety Notice

Read and understand all safety precautions and warnings before performing repairs.



This symbol appears in the manual when a potential safety hazard exists that can cause personal injury or death. These hazards are not always apparent to a trained mechanic.

It is not possible for Cummins Engine Co., Inc. to anticipate every possible circumstance that can involve a potential hazard.



Warning: Cummins Engine Company, Inc. does not recommend or authorize any modifications or repairs to engines or components except for those detailed in **CUMMINS SERVICE INFORMATION**.

In particular, unauthorized repair to safety-related components can cause personal injury. Below is a partial listing of components classified as safety-related:

- Air Compressor
- Air Controls
- Air Shutoff Assemblies
- Balance Weights
- Cooling Fan
- Fan Hub Assembly
- Fan Mounting Bracket(s)
- Fan Mounting Capscrews
- Fan Hub Spindle
- Flywheel
- Flywheel Crankshaft Adapter
- Flywheel Mounting Capscrews
- Fuel Shutoff Assemblies
- Fuel Supply Tubes
- Lifting Brackets
- Throttle Controls
- Turbocharger Compressor Casing
- Turbocharger Oil Drain Line(s)
- Turbocharger Oil Supply Line(s)
- Turbocharger Turbine Casing
- Vibration Damper Mounting Capscrews

Read and understand all of the safety precautions and warnings before performing any repair. This list contains the general safety precautions that must be followed to provide personal safety. Special safety precautions are included in the procedures when they apply.



Be sure the work area surrounding the product is safe. Be aware of hazardous conditions that can exist.



Always wear protective glasses and protective shoes when working.



Do not wear loose-fitting or torn clothing. Remove all jewelry such as rings, watches, etc., when working.



Disconnect the battery and discharge any capacitors before beginning any repair work. Disconnect the air starter if equipped to prevent accidental engine starting. Put a "Do Not Operate" tag in the operator's compartment or on the controls.

General Safety Instructions

Important Safety Notice



Use **ONLY** the proper engine barring techniques for manually rotating the engine. Do not attempt to rotate the engine by pulling or prying on the fan. This practice can cause serious personal injury, property damage, or damage to the fan blade(s) causing premature fan failure.



If an engine has been operating and the coolant is hot, allow the engine to cool before you slowly loosen the filler cap and relieve the pressure from the cooling system.



Do not work on anything that is supported **ONLY** by lift jacks or a hoist. Always use blocks or proper stands to support the product before performing any service work.



Relieve all pressure in the air, oil, and the cooling systems before any lines, fittings, or related items are removed or disconnected. Be alert for possible pressure when disconnecting any device from a system that utilizes pressure. Do not check for pressure leaks with your hand. High pressure oil or fuel can cause personal injury.



To prevent suffocation and frostbite, wear protective clothing and **ONLY** disconnect liquid refrigerant (freon) lines in a well ventilated area.



To avoid personal injury, use a hoist or get assistance when lifting components that weigh 23 kg [50 lbs] or more. Be sure all chains, hooks, slings, etc., are in good condition and are of the correct capacity. Be sure hooks are positioned correctly. Always use a spreader bar when necessary. The lifting hooks must not be side-loaded.



Corrosion inhibitor contains alkali. Do not get the substance in your eyes. Avoid prolonged or repeated contact with skin. Do not swallow internally. In case of contact, immediately wash skin with soap and water. In case of eye contact, immediately flood eyes with large amounts of water for a minimum of 15 minutes. **IMMEDIATELY CALL A PHYSICIAN. KEEP OUT OF REACH OF CHILDREN .**



Naptha and Methyl Ethyl Ketone (MEK) are flammable materials and must be used with caution. Follow the manufacturer's instructions to provide complete safety when using these materials. **KEEP OUT OF REACH OF CHILDREN.**



To avoid burns, be alert for hot parts on products that have just been turned **OFF**, and hot fluids in lines, tubes, and compartments.



Always use tools that are in good condition. Be sure you understand how to use them before performing any service work. Use **ONLY** genuine Cummins or Cummins Recon® replacement parts.



Always use the same fastener part number (or equivalent) when replacing fasteners. Do not use a fastener of less quality if replacements are necessary.

Generic Symbols

The following group of symbols have been used in this manual to help communicate the intent of the instructions. When one of the symbols appears, it conveys the meaning defined below.



WARNING - Serious personal injury or extensive property damage can result if the warning instructions are not followed.



CAUTION - Minor personal injury can result or a part, an assembly or the engine can be damaged if the caution instructions are not followed.



Indicates a **REMOVAL** or **DISASSEMBLY** step.



Indicates an **INSTALLATION** or **ASSEMBLY** step.



INSPECTION is required.



CLEAN the part or assembly.



PERFORM a mechanical or time **MEASUREMENT**.



LUBRICATE the part or assembly.



Indicates that a **WRENCH** or **TOOL SIZE** will be given.



TIGHTEN to a specific torque.



PERFORM an electrical **MEASUREMENT**.



Refer to another location in this manual or another publication for additional information.



The component weighs 23 kg [50 lb] or more. To avoid personal injury, use a hoist or get assistance to lift the component.

Illustrations

The illustrations used in this manual are intended to give an example of a problem, show what to look for and where to look for the problem. Most of the illustrations are generic and might not look exactly like the engine or parts used in your application. Some illustrations contain symbols to indicate an action required and an acceptable or unacceptable condition.

Unacceptable



Acceptable

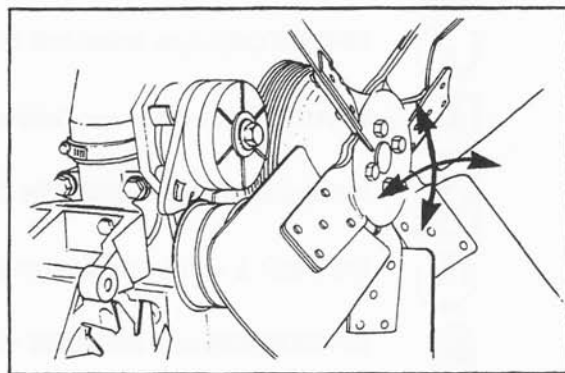
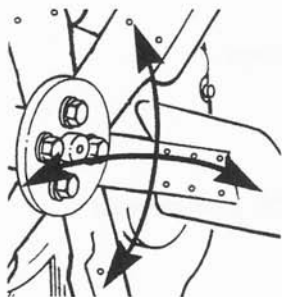
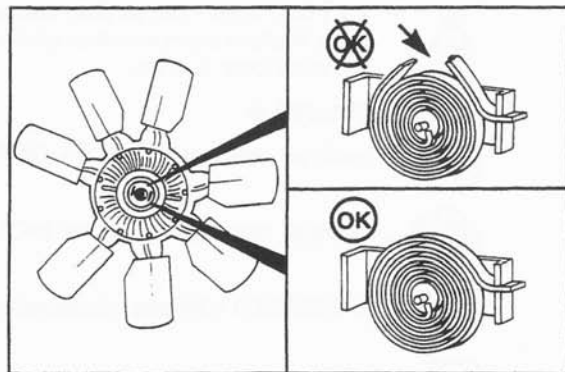

**Direction of Movement
(Action)**

Engine Dataplate

The engine dataplate shows specific information about your engine. The engine serial number (1) and Control Parts List (CPL) (2) provide information for ordering parts and service needs.

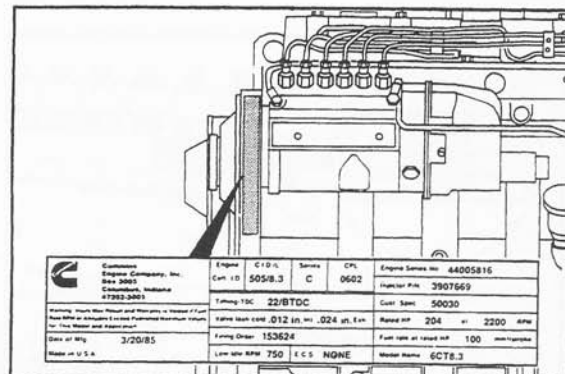

Cummins Engine Company, Inc. Box 3005 Columbus, Indiana 47202-3005	Engine Cert. I.D.	C.I.D./L. 305/8.3	Series C	CPL 0602	Engine Series No. 44005816
	Timing-TDC 22/BTDC				Injector P/N. 3907669
Warning: Injury May Result and Warranty is Voided if Fuel Rate RPM or Altitudes Exceed Published Maximum Values for This Model and Application.					Cust. Spec. 50030
Valve lash cold .010 in. Int. .020 in. Ex.					Rated HP 204 at 2200 RPM
Firing Order 153624					Fuel rate at rated HP 100 mm ³ /stroke
Date of Mfg. 3/20/85 Made in U.S.A.					Model Name 6CT8.3

How to Identify Your Engine

The model name provides the following engine data:

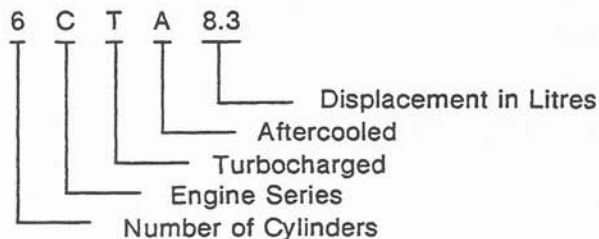

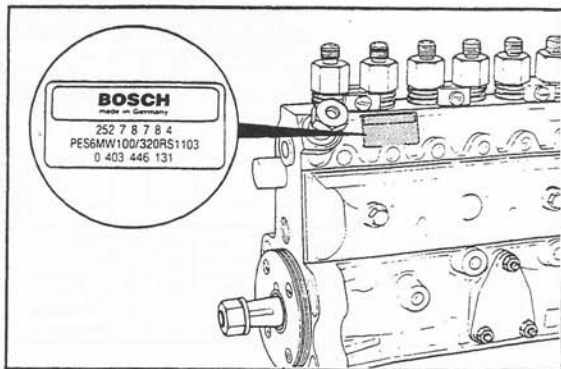

Fuel Pump Dataplate (Nameplate)

The fuel pump dataplate is located on the side of the fuel pump. It provides information for fuel pump calibration.

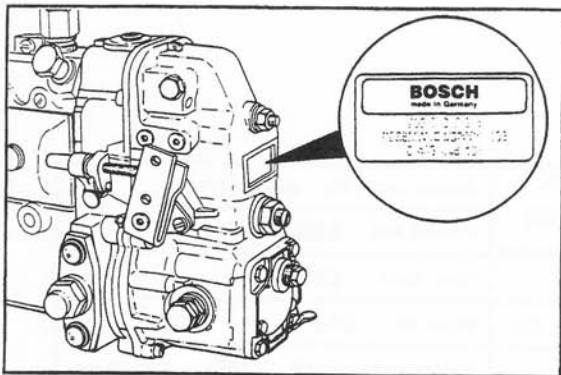

The Cummins part number for the fuel pump-governor combination is located on the governor dataplate.

External Engine Components

The pictures which follow show the locations of the major external engine components, the filters, and other service and maintenance points. Some external components will be at different locations for different engine models.

NOTE: The pictures are only a reference to show a typical engine.

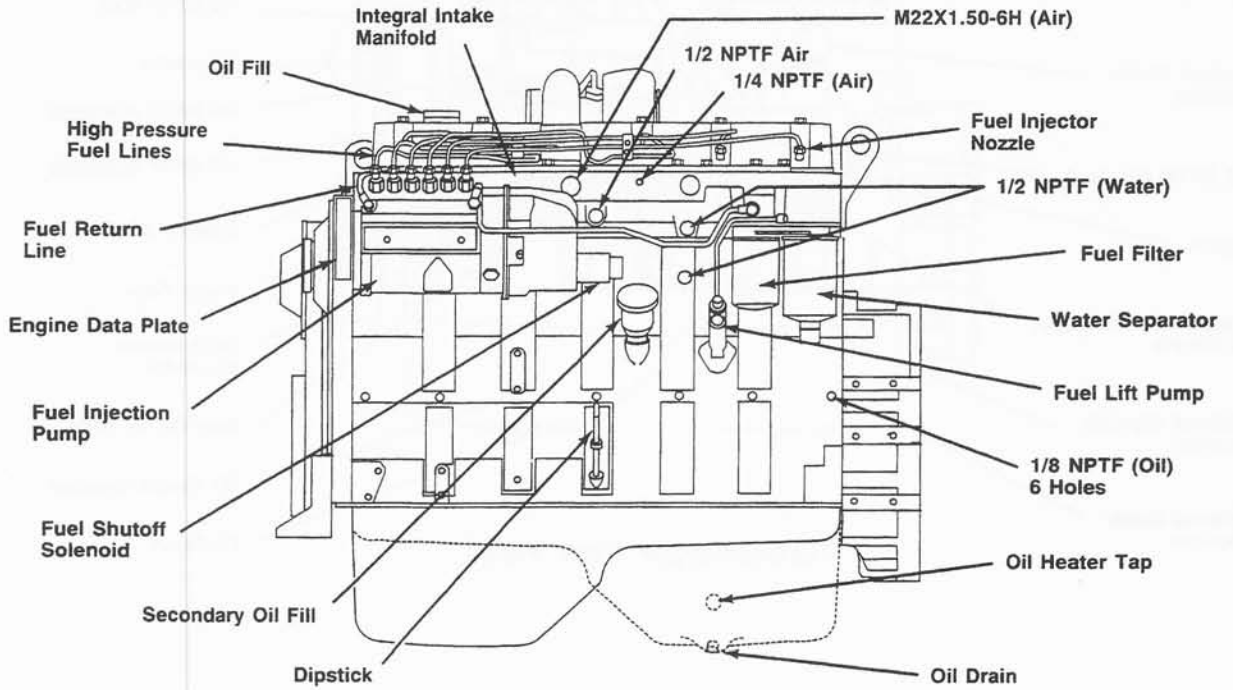

Fuel Pump Side View

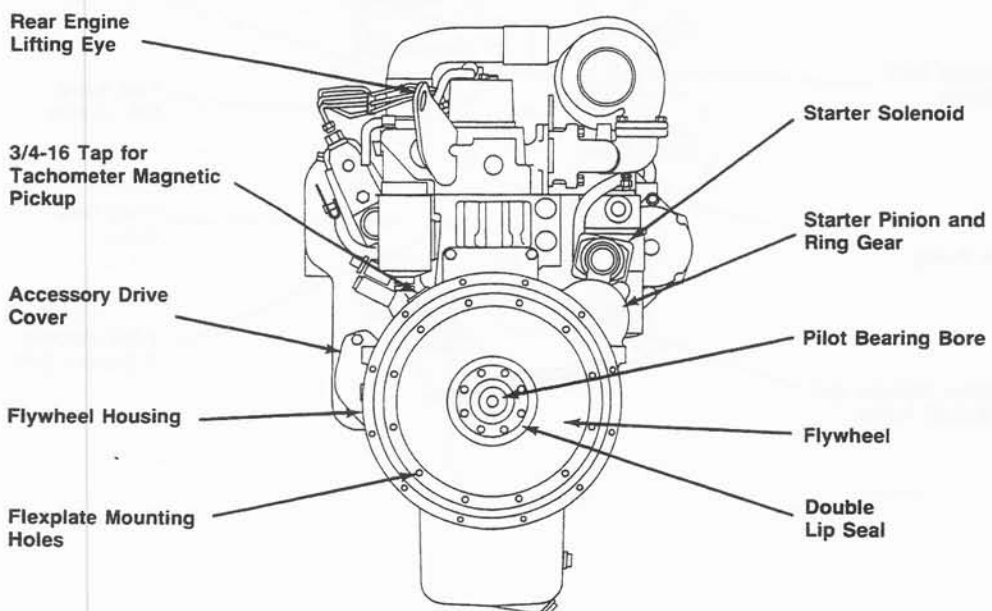

Rear View

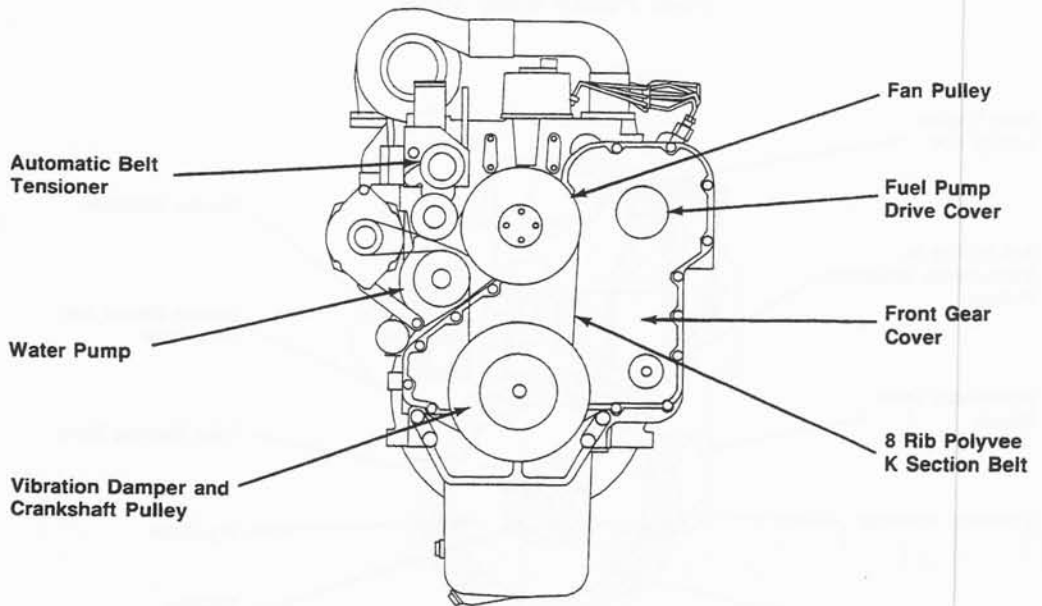
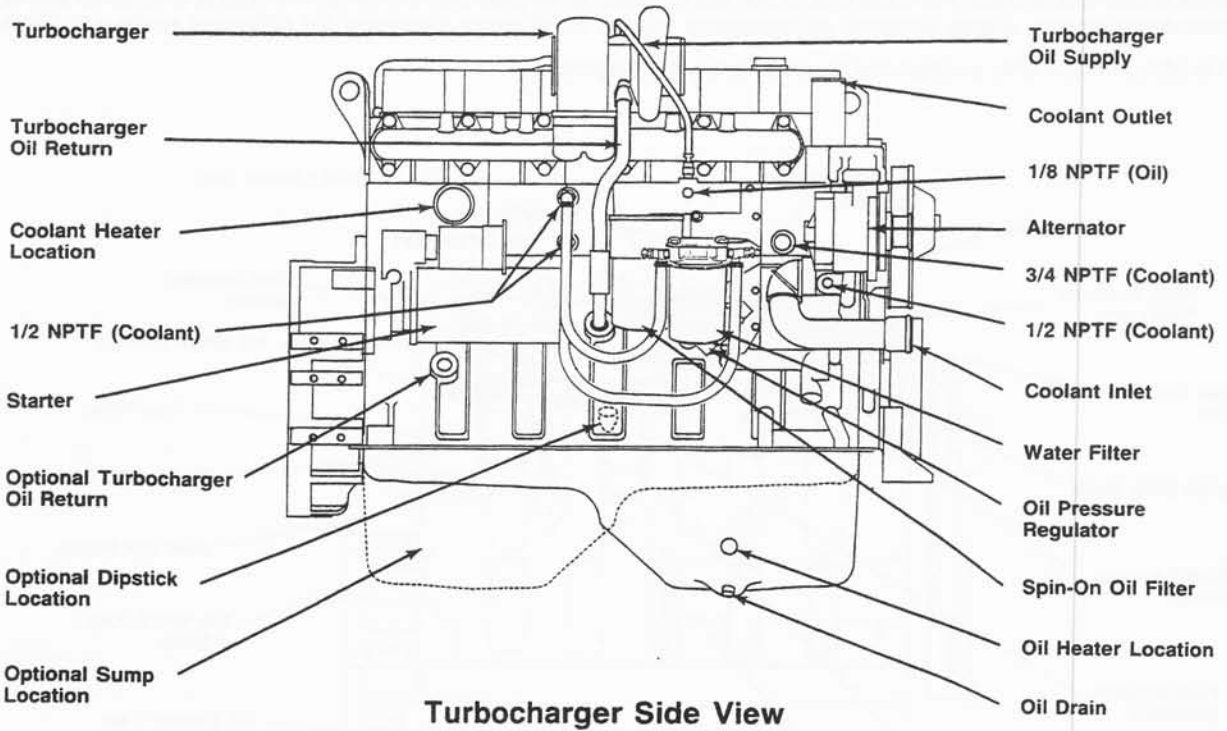

General Torque Specification

The C series engine uses parts that are of metric dimensions.

Always use caution to be sure that capscrews from the engine are put back in their proper locations.

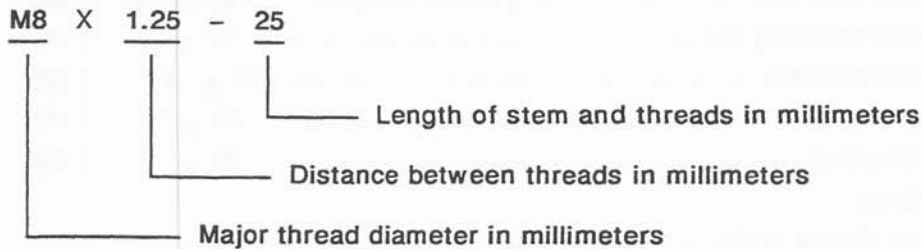

When replacing capscrews, always use a capscrew of the same measurement and strength as the capscrew being replaced. Incorrect capscrews can result in engine damage.

Metric Capscrew Nomenclature



Capscrew Markings and Torque Values - Metric

Metric capscrews are identified by the grade number stamped on the head of the capscrew or on the surface of metric nuts. The higher the number, the greater the strength of the capscrew.

Commercial Steel Class			
Thread Diameter	Torque	Torque	Torque
mm	N•m [ft-lb]	N•m [ft-lb]	N•m [ft-lb]
5	6 [5]	8 [6]	8 [6]
6	10 [5]	15 [10]	15 [10]
8	24 [18]	34 [25]	38 [28]
10	43 [32]	64 [47]	88 [57]
12	77 [57]	112 [83]	137 [101]
14	127 [94]	180 [133]	216 [159]
16	195 [144]	266 [196]	319 [235]

Notes:

1. Do not use these values when the torque values are specified in another section of the manual.
2. These values are based on clean, dry threads. Reduce the value by 10% when a lubricant is used. Reduce the value by 20% if new plated capscrews are used.

When the correct capscrew length is not known, apply the following general rule:

$$\text{Capscrew Length} = \text{Thread Engagement} + \text{Mounting Flange Width} + \text{Washer (Lock and Plain) Width.}$$

- The minimum Thread Engagement depends on the material the threads are machined in.
 - If the material is **cast iron or steel**, multiply the thread diameter by 1.5.
 - If the material is **aluminum**, multiply the thread diameter by 2.

C Series Torque Specifications

Socket Or Wrench Size mm (Inch)	Fastener	Torque ± N•m	(Ft-Lb)
10	Aftercooler Mounting	24 ± 3	(18)
8	Aftercooler Water Hose Clamp	5 ± 1	(4)
(15/16)	Air Compressor Gear Nut	125 ± 3	(93)
18	Air Compressor Mounting Nut	77 ± 7	(57)
19 & (9/16)	Air Compressor to Brace	43 ± 4	(32)
24	Air Compressor Water Line	35 ± 10	(25)
(15/16)	Alternator Pulley Nut	80 ± 8	(59)
8 Allen	(Alternator Shaft)		
13	Alternator Link (Delco 10 SI)	24 ± 3	(18)
16	Alternator Link (Delco 15 SI)	43 ± 4	(32)
19	Alternator Link (Delco 20-27 SI)	43 ± 4	(32)
13	Alternator Mounting Bolt (10-15 SI)	43 ± 4	(32)
15	Alternator Mounting Bolt (20-27 SI)	77 ± 7	(57)
10	Alternator Mounting Bracket	24 ± 3	(18)
13	Belt Tensioner to Bracket	43 ± 4	(32)
5 Allen	Belt Tensioner Bracket to Block	24 ± 3	(18)
13	Camshaft Thrust Plate	24 ± 3	(18)
12	Connecting Rod	40 ± 5	(30)
 Step 2	80 ± 5	(60)
 Step 3	120 ± 5	(88)
18	Crankshaft Damper	200 ± 12	(148)
8	Crossover Clamp	5 ± 1	(4)
15	Exhaust Manifold	43 ± 4	(32)
16	Exhaust Outlet Pipe Mounting	43 ± 4	(32)
11	Exhaust Outlet Pipe, "V" Band Clamp	5 ± 1	(4)
10	Fan Bracket Mounting	24 ± 3	(18)
13	Fan Hub (50mm Bolt Circle)	24 ± 3	(18)
16	Fan Hub (60 mm Bolt Circle)	43 ± 4	(32)
24	Flame Start Aid	40 ± 4	(30)
19	Flywheel	137 ± 7	(101)
18	Flywheel Housing	60 ± 6	(45)
10	Flywheel Housing Cover	24 ± 3	(18)
(1/2)	Flywheel Housing Drain Plug	43 ± 4	(32)
—	Front Cover Cap	—Hand Tighten—	
15	Front Engine Support Mounting	112 ± 10	(82)
	Front Engine Mounting Without Support	77 ± 7	(57)
17	Fuel Banjo Screw (In Filter Head)	32 ± 3	(24)
Slot	Fuel Vent Screw in Banjo	8 ± 1	(6)
75-80	Fuel Filter	3/4 Turn After Contact	
19	Fuel Low Pressure Supply at Pump	24 ± 3	(18)

C Series Torque Specifications

Socket Or Wrench Size mm (Inch)	Fastener	Torque ± N•m	(Ft-Lb)
19	Fuel Low Pressure Return at Pump.....	24 ± 2	(18)
24	Fuel Filter Adapter Nut.....	32 ± 3	(24)
17	Fuel Line Fitting (High Pressure).....	24 ± 3	(18)
22	Fuel Pump Drive Gear (A).....	93 ± 7	(68)
27	Fuel Pump Drive Gear (MW).....	105 ± 5	(77)
24	Fuel Pump Lock.....	15 ± 3	(11)
15	Fuel Pump Mounting Nut.....	43 ± 4	(32)
15	Fuel Solenoid Bracket.....	43 ± 4	(32)
10	Fuel Solenoid Mounting.....	10 ± 2	(7)
10	Gear Cover.....	24 ± 3	(18)
10	Gear Housing-to-Block.....	24 ± 3	(18)
(7/16)	Gear Housing Pipe Plugs.....	5 ± 1	(4)
18	Cylinder Head Mounting..... Step 1	50	(37)
 Step 2	150	(110)
 Step 3	200	(148)
10	Injector Fuel Drain Manifold.....	8 ± 1	(6)
10	Injector Retaining Capscrew.....	24 ± 3	(18)
10	Intake Manifold Cover.....	24 ± 3	(18)
10	Lift Pump Mounting/Cover Plate.....	24 ± 3	(18)
18	Lifting Bracket.....	77 ± 6	(57)
23	Main Bearing Cap..... Step 1	50	(37)
 Step 2	95	(70)
 Step 3	150	(110)
118-131	Oil Filter.....	3/4 Turn After Contact	
10	Oil Cooler Cover.....	24 ± 3	(18)
17	Oil Pan Drain Plug.....	80 ± 4	(60)
17	Oil Pan Heater Plug.....	80 ± 4	(60)
10	Oil Pan Mounting.....	24 ± 3	(18)
22	Oil Pressure Regulator Valve.....	80 ± 4	(60)
10	Oil Pump Mounting.....	24 ± 3	(18)
10	Oil Suction Tube (Flange).....	9 ± 1	(7)
10	Oil Suction Tube Brace.....	9 ± 1	(7)
15	PTO Adapter.....	77 ± 7	(57)
13	PTO Adapter Cover Plate A Drive.....	43 ± 4	(32)
15	PTO Adapter Cover Plate B Drive.....	77 ± 7	(57)
(3/4)	PTO Gear Nut A Drive.....	100 ± 10	(74)
(15/16)	PTO Gear Nut B Drive.....	134 ± 13	(100)
(11/16)	PTO Flange Companion.....	85 ± 8	(63)
10	Rocker Support.....	55 ± 3	(40.5)

C Series Torque Specifications

Socket Or Wrench Size mm (Inch)	Fastener	Torque \pm N•m	(Ft-Lb)
14	Rocker Lever Nut	24 \pm 3	(18)
15	Starter Mounting (12 Point).....	77 \pm 4	(57)
10	Tach Drive Retainer	3 \pm .5	(2)
10	Thermostat Housing	24 \pm 3	(18)
T-25 Torx	Timing Pin Flange Mounting.....	5 \pm 1	(4)
(1/2)	Turbine Housing.....	11 \pm 2	(8)
10	Turbocharger Compressor.....	8 \pm 1	(6)
15	Turbocharger Mounting Nut.....	32 \pm 3	(24)
10	Turbocharger Drain Tube	24 \pm 3	(18)
16	Turbocharger Oil Supply (Both Ends)	15 \pm 2	(11)
8	Water Hose Clamps	5	(4)
(3/8)	Water Inlet Plugs.....	34 \pm 3	(25)
10	Water Pump Mounting.....	24 \pm 3	(18)
15	Valve Cover.....	24 \pm 3	(18)
—	Valve Cover Oil Fill.....	Hand Tighten	
13	WABCO Air Compressor Gear.....	24 \pm 3	(18)
27	WABCO Gear Hub Mounting Nut	180 \pm 18	(133)

C Series Sealants

Use the sealants listed below or sealants containing equivalent properties.

Description	Sealing Method
1. Pipe Plugs	Precoated teflon or pipe sealer.
2. Gaskets	
a. Oil Pan	K&W Copper Coat [™] - Both Sides Apply Permatex [™] No. 2 to the four "T" joints and smear into the joints with finger until full.
b. Gear Cover	K&W Copper Coat [™] - Both Sides.
c. All Other Gaskets	No sealant required.
3. Cup Plugs	Loctite [™] 277 or Cummins Sealant 3375068.
4. O-rings	No sealant required.
5. Rear Camshaft Expansion Plug	Loctite [™] 277 or Cummins Sealant 3375068.
6. Fuel Pump Studs	Loctite [™] 609.
7. Turbocharger Drain (in block)	Loctite [™] 277 or Cummins Sealant 3375068.
8. Dipstick Tube (in block)	Loctite [™] 277 or Cummins Sealant 3375068.
9. Wet Flywheel Housing to Block	K&W Copper Coat [™] .
10. Front Seal (in gear cover)	Loctite [™] 277 or Cummins Sealant 3375068.
11. Rear Seal (in rear cover)	No sealant.
12. Timing Pin Housing Capscrews	Loctite [™] 59,241 liquid teflon.
13. Side Oil Fill	Loctite [™] 277 or Cummins Sealant 3375068.

C Series Lubricants

Use the lubricants listed below or lubricants containing equivalent properties.

Parts	Lubricant Required
Rod Bearings	Lubriplate™ 105
Main Bearings	Lubriplate™ 105
Cam Lobes and Journals	Lubriplate™ 105
Tappets	Lubriplate™ 105
Pistons	15W40 Engine Oil
Piston Rings	15W40 Engine Oil
Piston Pin	15W40 Engine Oil
Rocker Assemblies	15W40 Engine Oil
Push Tubes	Lubriplate™ 105 in cup
Liner O-Ring	15W40 Engine Oil
Cap screws - under head and on threads, as follows:	
● Main Bearing Cap screws	15W40 Engine Oil
● Cylinder Head Cap screws	15W40 Engine Oil
● Connecting Rod Cap screws	15W40 Engine Oil
● Flywheel Mounting Cap screws	15W40 Engine Oil
● Damper Mounting Cap screws	15W40 Engine Oil
● All Other Cap screws	Preservative Oil or 15W40 Engine Oil
Valve Stems (Cylinder Head Assembly)	90W or 140W Oil
Valve Stems (Engine Assembly)	Lubriplate™ 105
Front and Rear Seals to Crankshaft	Dry (use no lubricants)
Rear Seal	Soapy water to install seal in housing
Lube Oil Pressure Regulator	15W40 Engine