

Full download: <http://manualplace.com/download/cummins-power-generation-pcc3100-operation-service-manual/>

Caution: This document contains mixed page sizes (8.5 x 11 or 11 x 17), which may affect printing. Please adjust your printer settings according to the size of each page you wish to print.



Redistribution or publication of this document by any means, is strictly prohibited.

Operation/Service Manual

Digital Paralleling GenSet Model

DFAA, DFAB, DFAC, DFBC, DFBD, DFBE, DFBF,
DFCB, DFCC, DFCE, DFEB, DFEC, DFED, DFFA,
DFFB, DFGA, DFGB, DFGC, DFJA, DFJB, DFJC,
DFJD, DFLA, DFLB, DFLC, DFLD, DFLE, DFMB,
DQAA, DQAB, DQBA, DQBB

with PowerCommand[®] Control
PCC3100

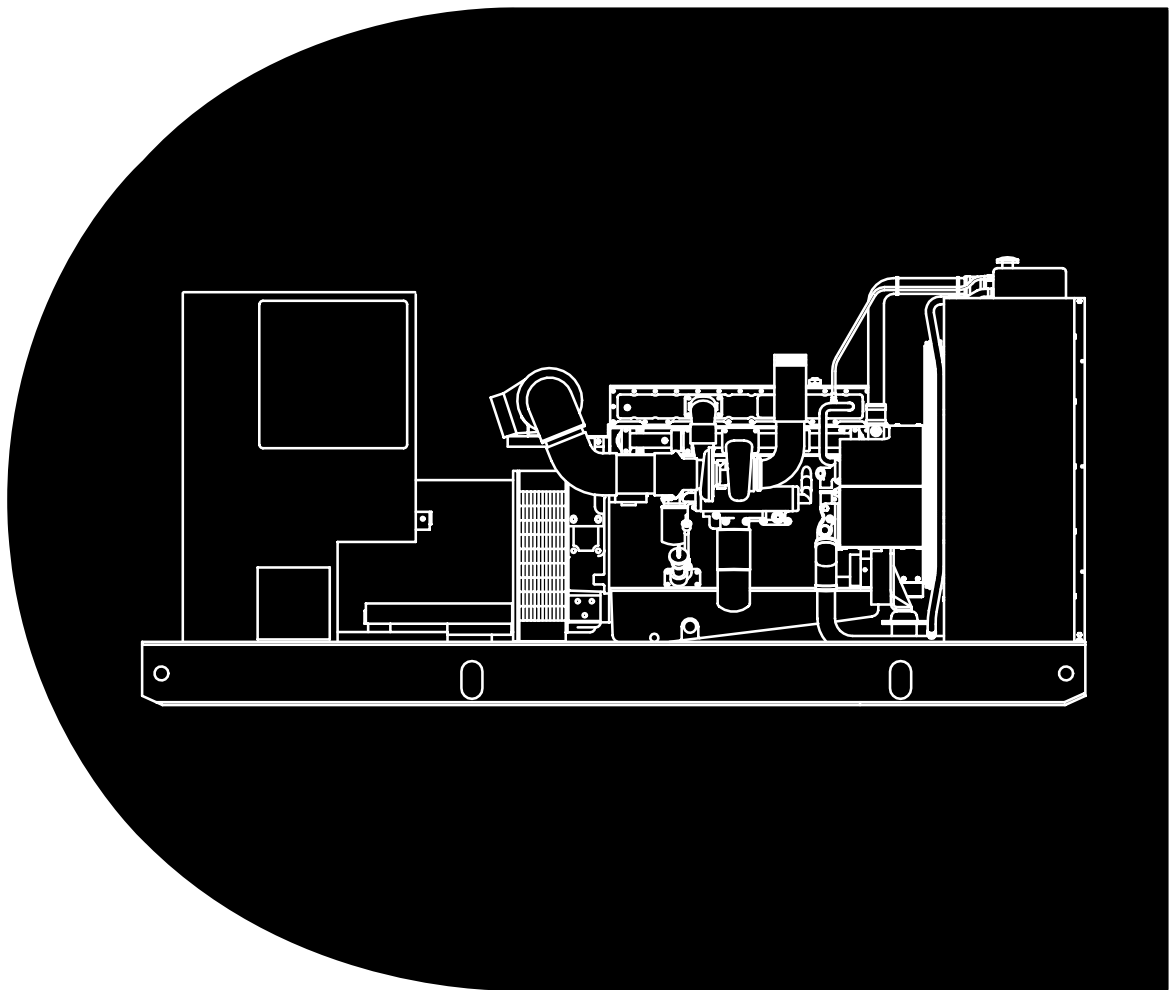

Table of Contents

SECTION	TITLE	PAGE
	SAFETY PRECAUTIONS	iii
1	INTRODUCTION	
	About this Manual	1-1
	Test Equipment	1-1
	How To Obtain Service	1-1
	System Overview	1-2
	Generator Set Control Function	1-2
2	CONTROL OPERATION	2-1
	General	2-1
	Safety Considerations	2-1
	Sequence of Operation	2-2
	PCC Power On/Standby Mode	2-2
	Front Panel	2-4
	Menu Display and Switches	2-6
	Main Menu	2-6
	Engine Menu	2-8
	Gen Menu	2-10
3	CIRCUIT BOARDS AND MODULES	
	General	3-1
	Digital Board (A32)	3-3
	Engine Interface Board (A31)	3-4
	Analog Board (A33)	3-6
	Digital Display Board (A35)	3-7
	Customer Interface Board (A34)	3-8
	PT/CT Board (A36)	3-10
	Bus PT Board (A39)	3-11
	Genset Communications Module (A41)	3-12
	Voltage Regulator Output Module (A37)	3-13
	Governor Output Module (A38)	3-14
	Master First Start Sensor	3-15
4	TROUBLESHOOTING	
	General	4-1
	Safety Considerations	4-1
	Status Indicators	4-2
	Resetting the Control	4-2
	Warning and Shutdown Codes	4-3
	PCC Oil Pressure Warning and Shutdown Limits	4-12
	Troubleshooting Procedure	4-13
	PCC Fuses	4-56
	Load Sharing Controls Troubleshooting Procedure	4-57

SECTION	TITLE	PAGE
5	CONTROL SERVICE AND CALIBRATION	
	General	5-1
	Circuit Board Removal/Replacement	5-1
	Initial Start Setup Menu	5-4
	Adjust Menu	5-6
	Setup and Calibration Menus	5-8
	Calibration Procedure	5-26
	Accessory Box Control Components	5-29
	Engine Sensors	5-42
	Magnetic Speed Pickup Unit (MPU) Installation	5-46
	Current Transformer (CT) Installation	5-47
6	SERVICING THE GENERATOR	
	Testing the Generator	6-1
	Generator/PCC Control Isolation Procedure	6-2
	Insulation Resistance (Megger) & Polarization Index (PI) Testing	6-3
	Drying the Windings	6-5
	Exciter Stator	6-6
	Exciter Rectifier Bridge (Rotating Rectifier Assembly)	6-7
	Exciter Rotor	6-8
	Main Rotor (Generator Field)	6-9
	Main Stator	6-10
	Test the PMG	6-12
	Bearing Inspection/Removal/Replacement	6-13
	Generator Disassembly	6-15
	Generator Reassembly	6-24
	Aligning Generator with Engine	6-28
7	DAY TANK FUEL TRANSFER PUMP AND CONTROL	
	Operation	7-2
	Wiring Connections	7-4
	Fuel Transfer Pump Motor Connections	7-6
	Testing the Float Switch Assembly	7-7
8	INITIAL SYSTEM STARTUP	
	General	8-1
	The Startup Process	8-1
	Equipment Application Review	8-2
	Individual Generator Set Startup	8-2
	Manual System Operation	8-4
	Automatic System Operation	8-7
	Black Start Testing	8-8
	Test Reports and Acceptance	8-8
	On Site Power System Application Review (Diesel/600VAC and Lower)	8-9
9	WIRING DIAGRAMS	
	General	9-1

IMPORTANT SAFETY INSTRUCTIONS

SAVE THESE INSTRUCTIONS – This manual contains important instructions that should be followed during installation and maintenance of the generator and batteries.

Before operating the generator set (genset), read the Operator's Manual and become familiar with it and the equipment. **Safe and efficient operation can be achieved only if the equipment is properly operated and maintained.** Many accidents are caused by failure to follow fundamental rules and precautions.

The following symbols, found throughout this manual, alert you to potentially dangerous conditions to the operator, service personnel, or the equipment.

⚠ DANGER *This symbol warns of immediate hazards which will result in severe personal injury or death.*

⚠ WARNING *This symbol refers to a hazard or unsafe practice which can result in severe personal injury or death.*

⚠ CAUTION *This symbol refers to a hazard or unsafe practice which can result in personal injury or product or property damage.*

FUEL AND FUMES ARE FLAMMABLE

Fire, explosion, and personal injury or death can result from improper practices.

- DO NOT fill fuel tanks while engine is running, unless tanks are outside the engine compartment. Fuel contact with hot engine or exhaust is a potential fire hazard.
- DO NOT permit any flame, cigarette, pilot light, spark, arcing equipment, or other ignition source near the generator set or fuel tank.
- Fuel lines must be adequately secured and free of leaks. Fuel connection at the engine should be made with an approved flexible line. Do not use zinc coated or copper fuel lines with diesel fuel.
- Be sure all fuel supplies have a positive shutoff valve.
- Be sure battery area has been well-ventilated prior to servicing near it. Lead-acid batteries emit a highly explosive hydrogen gas that can be ignited by arcing, sparking, smoking, etc.

EXHAUST GASES ARE DEADLY

- Provide an adequate exhaust system to properly expel discharged gases away from enclosed or sheltered areas and areas where individuals are likely to congregate. Visually and audibly inspect the exhaust daily for leaks per the maintenance schedule. Make sure that exhaust manifolds are secured and not warped. Do not use exhaust gases to heat a compartment.
- Be sure the unit is well ventilated.
- Engine exhaust and some of its constituents are known to the state of California to cause cancer, birth defects, and other reproductive harm.

MOVING PARTS CAN CAUSE SEVERE PERSONAL INJURY OR DEATH

- Keep your hands, clothing, and jewelry away from moving parts.
- Before starting work on the generator set, disconnect battery charger from its AC source, then disconnect starting batteries, negative (–) cable first. This will prevent accidental starting.
- Make sure that fasteners on the generator set are secure. Tighten supports and clamps, keep guards in position over fans, drive belts, etc.
- Do not wear loose clothing or jewelry in the vicinity of moving parts, or while working on electrical equipment. Loose clothing and jewelry can become caught in moving parts.
- If adjustment must be made while the unit is running, use extreme caution around hot manifolds, moving parts, etc.

DO NOT OPERATE IN FLAMMABLE AND EXPLOSIVE ENVIRONMENTS

Flammable vapor can cause an engine to overspeed and become difficult to stop, resulting in possible fire, explosion, severe personal injury and death. Do not operate a genset where a flammable vapor environment can be created by fuel spill, leak, etc., unless the genset is equipped with an automatic safety device to block the air intake and stop the engine. The owners and operators of the genset are solely responsible for operating the genset safely. Contact your authorized Cummins Power Generation distributor for more information.

ELECTRICAL SHOCK CAN CAUSE SEVERE PERSONAL INJURY OR DEATH

- Remove electric power before removing protective shields or touching electrical equipment. Use rubber insulative mats placed on dry wood platforms over floors that are metal or concrete when around electrical equipment. Do not wear damp clothing (particularly wet shoes) or allow skin surface to be damp when handling electrical equipment. Do not wear jewelry. Jewelry can short out electrical contacts and cause shock or burning.
- Use extreme caution when working on electrical components. High voltages can cause injury or death. DO NOT tamper with interlocks.
- Follow all applicable state and local electrical codes. Have all electrical installations performed by a qualified licensed electrician. Tag and lock open switches to avoid accidental closure.
- DO NOT CONNECT GENERATOR SET DIRECTLY TO ANY BUILDING ELECTRICAL SYSTEM. Hazardous voltages can flow from the generator set into the utility line. This creates a potential for electrocution or property damage. Connect only through an approved isolation switch or an approved paralleling device.

MEDIUM VOLTAGE GENERATOR SETS (601V to 15kV)

- Medium voltage acts differently than low voltage. Special equipment and training is required to work on or around medium voltage equipment. Operation and maintenance must be done only by persons trained and qualified to work on such devices. Improper use or procedures will result in severe personal injury or death.
- Do not work on energized equipment. Unauthorized personnel must not be permitted near energized equipment. Due to the nature of medium voltage electrical equipment, induced voltage remains even after the equipment is disconnected from the power source. Plan the time for maintenance with authorized personnel so that the equipment can be de-energized and safely grounded.

GENERAL SAFETY PRECAUTIONS

- Coolants under pressure have a higher boiling point than water. DO NOT open a radiator or heat ex-

changer pressure cap while the engine is running. To prevent severe scalding, let engine cool down before removing coolant pressure cap. Turn cap slowly, and do not open it fully until the pressure has been relieved.

- Used engine oils have been identified by some state or federal agencies as causing cancer or reproductive toxicity. When checking or changing engine oil, take care not to ingest, breathe the fumes, or contact used oil.
- Keep multi-class ABC fire extinguishers handy. Class A fires involve ordinary combustible materials such as wood and cloth; Class B fires, combustible and flammable liquid fuels and gaseous fuels; Class C fires, live electrical equipment. (ref. NFPA No. 10).
- Make sure that rags are not left on or near the generator set.
- Make sure generator set is mounted in a manner to prevent combustible materials from accumulating under or near the unit.
- Remove all unnecessary grease and oil from the unit. Accumulated grease and oil can cause overheating and engine damage which present a potential fire hazard.
- Keep the generator set and the surrounding area clean and free from obstructions. Remove any debris from the set and keep the floor clean and dry.
- Do not work on this equipment when mentally or physically fatigued, or after consuming any alcohol or drug that makes the operation of equipment unsafe.
- Substances in exhaust gases have been identified by some state or federal agencies as causing cancer or reproductive toxicity. Take care not to breathe or ingest or come into contact with exhaust gases.
- Do not store any flammable liquids, such as fuel, cleaners, oil, etc., near the generator set. A fire or explosion could result.
- Wear hearing protection when going near an operating generator set.
- To prevent serious burns, avoid contact with hot metal parts such as radiator system, turbo charger system and exhaust system.

KEEP THIS MANUAL NEAR THE GENSET FOR EASY REFERENCE

1. Introduction

ABOUT THIS MANUAL

This manual provides troubleshooting and repair information regarding the PowerCommand® Control 3100 (PCC) and generators for the generator set (genset) models listed on the front cover. Engine service instructions are in the applicable engine service manual. Operating and maintenance instructions are in the applicable Operator's Manual.

This manual does not have instructions for servicing printed circuit board assemblies. After determining that a printed circuit board assembly is faulty, replace it. Do not repair it. Attempts to repair a printed circuit board can lead to costly damage to the equipment.

This manual contains basic (generic) wiring diagrams and schematics that are included to help in troubleshooting. Service personnel must use the actual wiring diagram and schematic shipped with each unit. The wiring diagrams and schematics that are maintained with the unit should be updated when modifications are made to the unit.

Read **Safety Precautions** and carefully observe all instructions and precautions in this manual.

TEST EQUIPMENT

To perform the test procedures in this manual, the following test equipment must be available

- True RMS meter for accurate measurement of small AC and DC voltages. Fluke models 87 or 8060A are good choices.
- Grounding wrist strap to prevent circuit board damage due to electrostatic discharge (ESD).
- Battery Hydrometer
- Jumper Leads
- Tachometer or Frequency Meter
- Wheatstone Bridge or Digital Ohmmeter
- Variac
- Load Test Panel
- Megger or Insulation Resistance Meter
- PCC Service Tool Kit (Harness Tool and Sensor Tool)

HOW TO OBTAIN SERVICE

Always give the complete Model, Specification and Serial number of the generator set as shown on the nameplate when seeking additional service information or replacement parts. The nameplate is located on the side of the generator output box.

⚠WARNING *Incorrect service or replacement of parts can result in severe personal injury or death, and/or equipment damage. Service personnel must be trained and experienced to perform electrical and mechanical service. Read and follow Safety Precautions, on pages iii and iv.*

SYSTEM OVERVIEW

The PCC is a microprocessor-based control for Cummins generator sets. It provides fuel control and engine speed governing, main alternator voltage output regulation, and complete generator set control and monitoring. It also provides controls for automatic and semi-automatic synchronizing and automatic load sharing controls for both isolated bus or utility (mains) paralleling applications.

The operating software provides control of the generator set and its performance characteristics, and displays performance information on a digital display panel. It accepts menu-driven control and setup input from the push button switches on the front panel.

GENERATOR SET CONTROL FUNCTION

Figure 1-1 shows some of the control functions. A more complete block diagram is provided in Section 3. A system schematic is provided in Section 9.

The PCC monitors frequency from both the magnetic pick-up (MPU) and the main stator inputs. The control sends a low power pulse-width modulated (PWM) signal to the governor output module, which then sends an amplified signal to the engine fuel control.

The Bus PT module reduces the bus voltage to approximately 18 VAC and provides a signal to the control for reference in synchronizing the generator set to the system bus.

The external PT/CT module reduces generator voltage to approximately 18 VAC, and produces a representative AC voltage from CT output current. The voltage regulation function sends a low power PWM signal to the voltage regulator output module, which then sends an amplified signal to the exciter stator.

Oil, coolant, and exhaust temperatures are sensed by variable resistance element sensors. Oil pressure is sensed by a capacitive element active sensor.

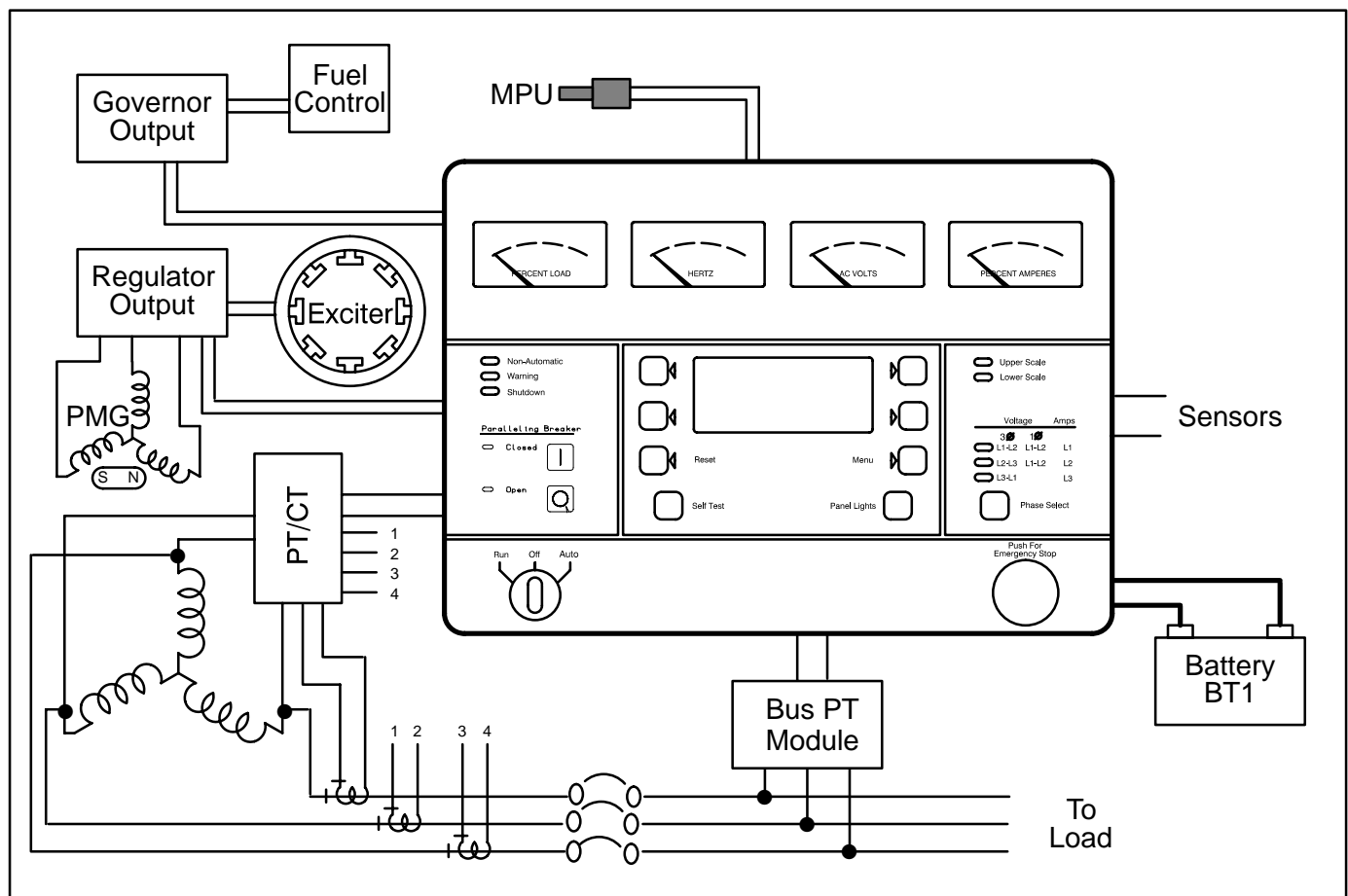

FIGURE 1-1. GENERATOR SET CONTROL FUNCTIONS

2. Control Operation

GENERAL

The following describes the function and operation of the PowerCommand generator set control. All indicators, displays, meters and control switches are located on the face of the control panel as illustrated in Figure 2-1.

The PCC control cabinet must be opened only by technically qualified personnel.

Normally, generator set configuration options are set at the factory. When a new control is installed on a generator set or when parts are replaced, the control must be configured for that generator set with the use of the “Initial Start Setup” portion of the internal software. Setup and calibration procedures are described in *Section 5*.

The automatic voltage regulator (AVR) and governor operation characteristic adjustments are also described in *Section 5*.

SAFETY CONSIDERATIONS

AC power is present when the set is running. Do not open the generator output box while the set is running.

⚠ WARNING *Contacting high voltage components can cause electrocution, resulting in severe personal injury or death. Do not open the generator output box while the set is running. Read and observe all WARNINGS and CAUTIONS in your generator set manuals.*

⚠ CAUTION *The PCC control cabinet must be opened only by technically qualified personnel. Lower level voltages (18 VAC to 24 VDC) are present in PCC control cabinet. These voltages can cause electrical shock, resulting in personal injury.*

Even with power removed, improper handling of components can cause electrostatic discharge and damage to circuit components.

SEQUENCE OF OPERATION

When the PowerCommand control is in the AUTO mode, it will cause the generator set to start on receiving a signal from a remote device. The PowerCommand control will initiate a starter cranking signal and verify that the engine is rotating. The PowerCommand control will provide sufficient fuel to the engine to accelerate to start disconnect speed. On reaching that speed, the control will ramp the generator set to rated speed and voltage.

On reaching rated speed and voltage, the PowerCommand control checks the system bus voltage. If no bus voltage is present, it will wait for a pulse from a remote Master First Start Sensor. On receiving that pulse, the control will signal the paralleling breaker to close.

If bus voltage is present, the PowerCommand control will check for proper phase rotation, adjust the generator set to the bus voltage and frequency level, and then synchronize the generator set to the system bus. When a synchronous condition is achieved, the control will send a signal to close the paralleling breaker.

When the paralleling breaker is closed, the generator set will assume its proportional share of the total load on the system bus.

PCC POWER ON / STANDBY MODE

Standby Mode

In the Standby (sleep) mode (selector switch S5 on the Digital Board is set to the right and the generator set is not running), the control's operating software is inactive and the LEDs and displays on front panel are all off.

The operating software is initialized and the front panel is turned on in response to a run signal or any

one of eight "wake up" inputs from remote sensing switches.

The wake up signals are:

- Emergency Stop
- Low Coolant Level
- Low Coolant Temperature
- Low Fuel
- Customer Fault Inputs 2 and 3
- Run Selected on Run/Off/Auto Switch
- Remote Start Signal in Auto Mode
- Self Test switch

To activate and view the menu displays, press and release the Self Test switch. The PCC will initialize the operating software and permit operation of the menu display panel. If no menu selections are made, the power to the control panel will shut down after 30 seconds.

Power On Mode

In the Power On (awake) mode (selector switch S5 on the Digital Board is set to the left), the PCC will initialize the operating software and permit operation of the menu display panel. (See Figure 3-1 for S5 location.) Power will stay on until switch (S5) is set to the Standby mode. It is recommended that switch S5 be left in the Power On mode in all applications, except those where auxiliary battery charging is not available.

⚠ CAUTION *Electrostatic discharge will damage circuit boards. Always wear a grounding wrist strap when touching or handling circuit boards or socket-mounted ICs and when disconnecting or connecting harness connectors.*

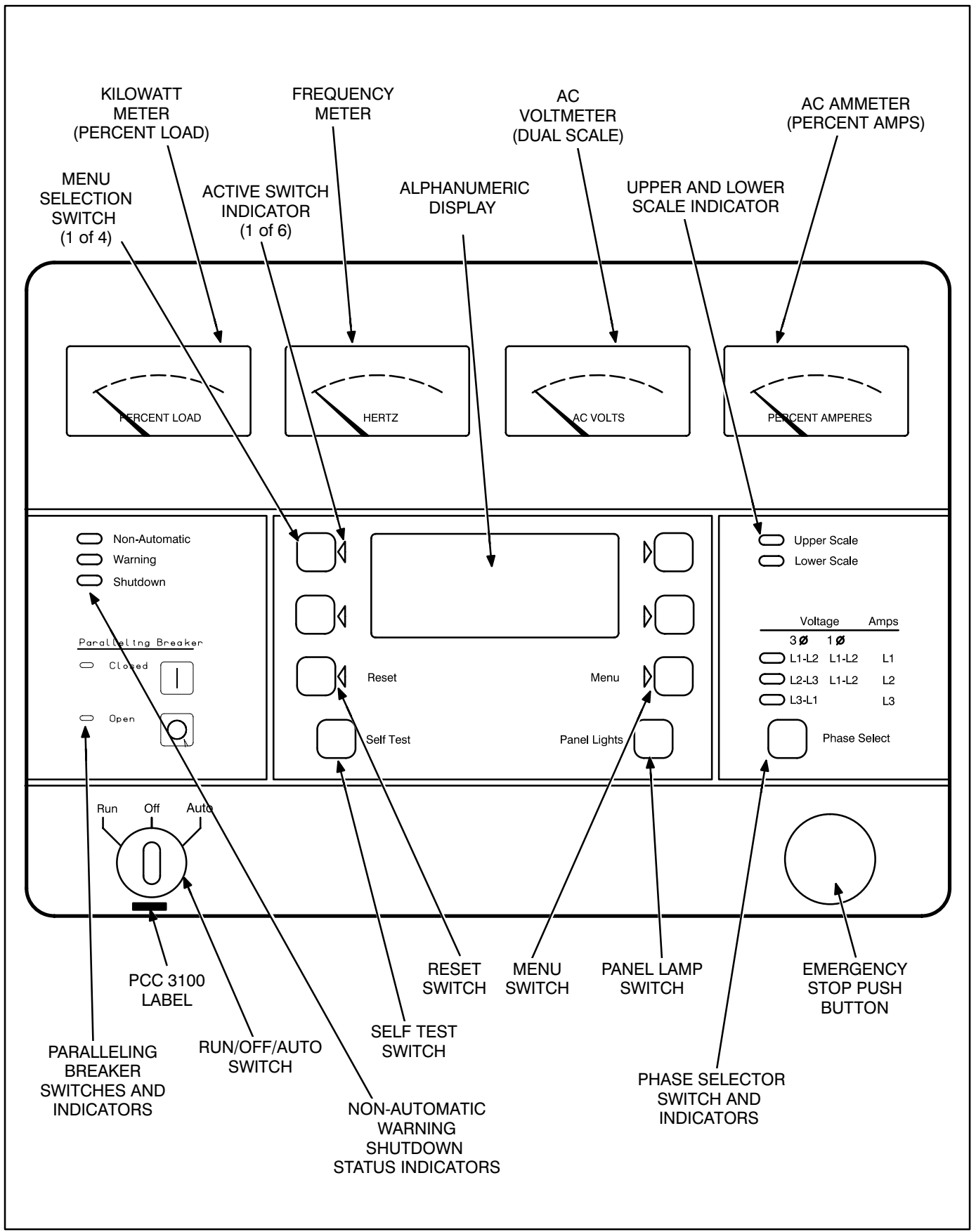

FIGURE 2-1. FRONT PANEL (PCC 3100)

FRONT PANEL

Figure 2-1 shows the features of the front panel.

AC Voltmeter: Dual scale instrument indicates AC voltage. Measurement scale in use is shown on scale indicator lamp.

AC Ammeter: Indicates current output in percent of maximum rated current. (Percent current is based on .8 PF.)

Kilowatt Meter: Indicates 3-phase AC power output as percent of rated load.

Frequency Meter: Indicates generator output frequency in hertz.

Upper and Lower Scale Indicator Lamps: Indicate AC voltmeter scale.

Digital Display: This two-line, 16-character per line alphanumeric display is used in the menu-driven operating system, in conjunction with the display menu selection switches and the Menu switch. Refer to the menu trees later in this section. The display is also used to show warning and shutdown messages.

Display Menu Selection Switches: Four momentary switches—two on each side of the digital display window—are used to step through the various menu options and to adjust generator set parameters. The green arrow adjacent to the switch is lit when the switch can be used (switch is “active”).

Menu Switch: Press this switch to return the digital display to the MAIN MENU. Refer to the menu trees later in this section.

Reset Switch: Press this switch to reset warning and shutdown messages after the condition has been corrected. To reset a shutdown message with the Reset switch, the Run/Off/Auto switch must be in the Off position.

With the Run/Off/Auto switch in the Auto mode, shutdown faults can be reset by removing the remote start input and then cycling the remote reset input.

Self Test Switch: Press and hold this switch to light all front panel LEDs and cycle through all shutdown and warning messages.

In the Standby (sleep) mode, with the generator set not running, the control's operating software is inactive and the LEDs and displays on front panel are all off.

To activate and view the menu displays without starting the generator set, press and hold the Self Test switch until the front panel LEDs light. The PCC will initialize the operating software and permit operation of the menu display panel. If no menu selections are made, a software timer will shut down the power after 30 seconds.

Panel Lights Switch: Press this switch to turn control panel illumination on and off. The illumination will shut off after about eight minutes.

Phase Selector Switch and Indicators: Press this momentary switch to select phases of generator output to be measured by the analog AC voltmeter and ammeter. LEDs indicate the selected phase.

Run/Off/Auto Switch: This switch starts and stops the set locally, or enables start/stop control of the engine from a remote location. (Ground to start.)

Emergency Stop Button: Push the button in for emergency shutdown of the engine.

Remote Reset switch will not reset emergency stop. Can only be reset at the PCC front panel.

To reset:

1. Pull the button out or turn the button clockwise (button with arrow) and allow it to pop out.
2. Move the Run/Off/Auto switch to Off.
3. Press the front panel Reset switch.
4. Select Run or Auto, as required.

Non-Automatic Status Indicator: This red lamp flashes continuously when the Run/Off/Auto switch is not in the Auto position.

Warning Status Indicator: This yellow lamp is lit whenever the control detects a warning condition. After the condition is corrected, warning indicators can be reset by pressing the Reset switch. (It is **not** necessary to stop the generator set.)

With the Run/Off/Auto switch in the Auto mode, warnings can also be reset by cycling the remote reset input after the condition is corrected.

Shutdown Status Indicator: This red lamp is lit whenever the control detects a shutdown condition. After the condition is corrected, shutdown indicators can be reset by turning the Run/Off/Auto switch to the Off position, and pressing the Reset switch. In Auto mode, shutdowns can be reset by removing the remote start input and then cycling the remote reset input.

Emergency Stop shutdown status (Code 102) can be reset only at the PCC front panel.

Paralleling Breaker Switches and Indicators: These two switches are used to manually open or close the paralleling breaker of the generator set. The lamps are used to indicate the opened or closed position of the paralleling breaker.

The Breaker Operation switches are operational only when the Run/Off/Auto switch is in the Run position. The breaker will close when the generator set is synchronized with the system bus, or if the system bus is de-energized.

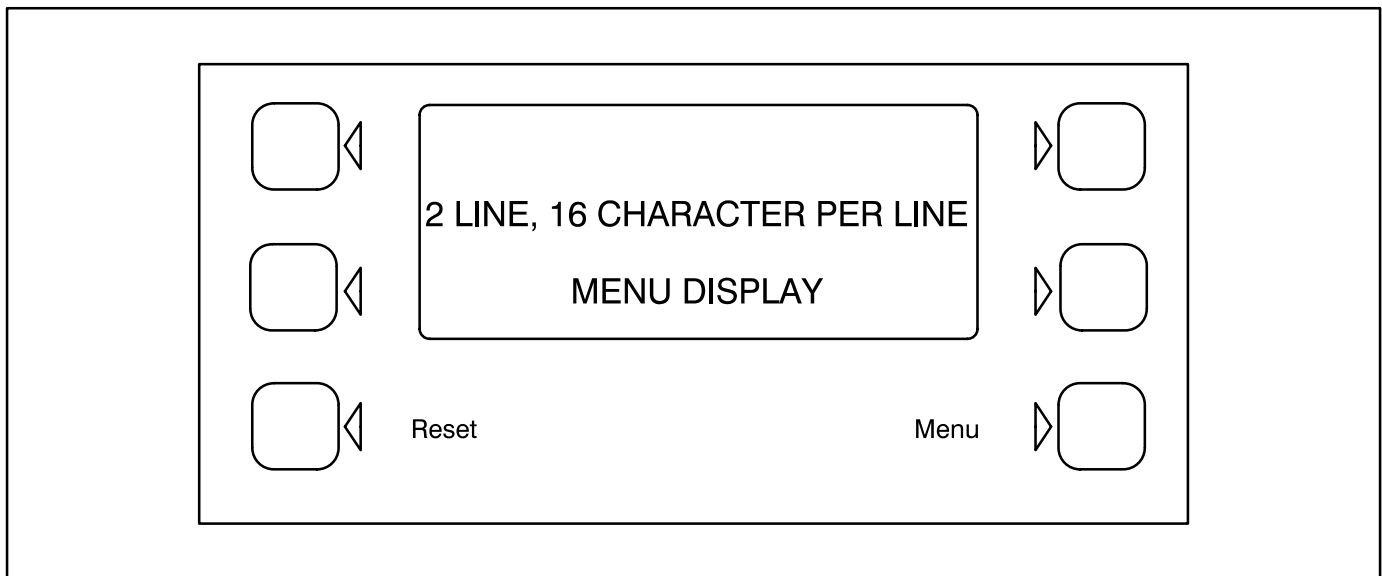

FIGURE 2-2. DIGITAL DISPLAY AND MENU SELECTION SWITCHES

MENU DISPLAY AND SWITCHES

Figure 2-2 shows the digital display and the menu selection switches. Refer to heading “*Front Panel*” which describes the menu display and switches.

In the Standby Mode, to activate and view the menu displays without starting the generator set, press and release the Self Test switch. This will initialize the PCC operating software and permit operation of the menu display panel. If no menu selections are made, a software timer will shut down the power after 30 seconds. In the Power On Mode, power is continuously supplied to the control panel. Display will always remain on.

In the digital display, the “>>” symbol indicates that selecting the adjacent button causes the operating program to branch to the next menu display—as shown in the menu diagrams.

In the digital display, the “<<” symbol indicates that selecting the adjacent button causes the operating program to go back to the previous menu display.

MAIN MENU

The facing page shows the main menu and a block representation of the available submenus.

As shown in the diagram, the main menu can branch into one of four directions.

To display engine parameters, such as oil pressure and temperature, water temperature, engine speed (RPM), and exhaust temperature, press the button next to the word “ENGINE” in the display. Refer to *ENGINE MENU* in this section.

To display generator parameters, such as volts, amps, power (kW), and frequency, press the button next to the word “GEN” in the display. Bus voltage, frequency and a digital synchroscope can also be viewed from this menu branch. Turn to the *GEN MENU* in this section.

To adjust output voltage and frequency, or start and stop delays, press the button next to the word “ADJUST” in the display. Refer to *ADJUST MENU* in *Section 5*.

To display the selected generator set model and the resident version software, press the button next to the “>>” in the display. Refer to *VERSION & DISPLAYS MENU* in *Section 5*.

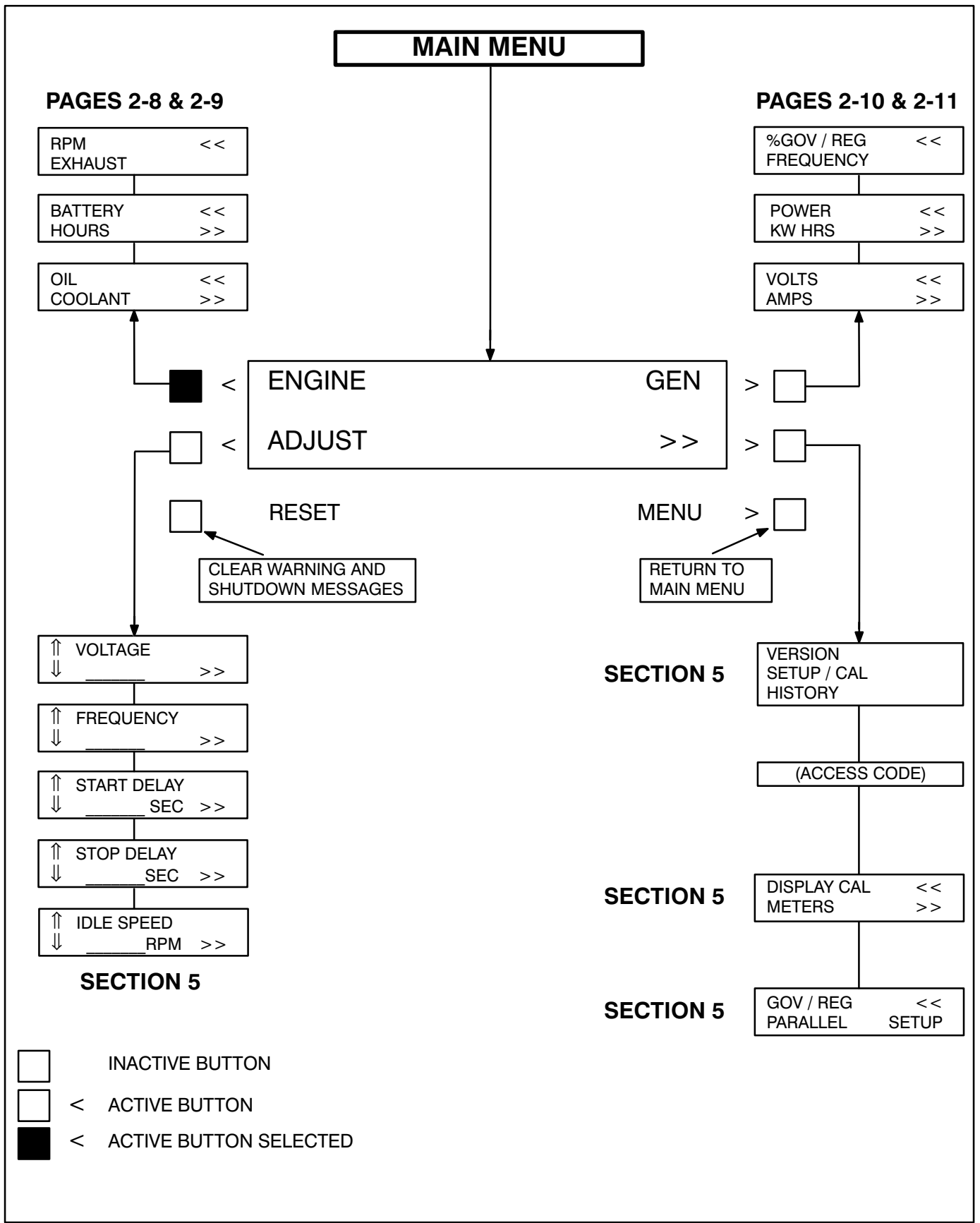

ENGINE MENU

The facing page shows a block representation of the ENGINE menu. If you press the button next to the word “ENGINE” in the display, the first ENGINE submenu will appear.

As shown in the diagram, the ENGINE menu has three submenus.

OIL/COOLANT submenu: This is the first submenu. Select OIL for a display of oil pressure and oil temperature. Select COOLANT for a display of coolant temperature. When oil or coolant parameters are displayed, pressing the button next to the “<<” will return the display (“BACK”) to the OIL/COOLANT submenu.

BATTERY/HOURS submenu: From the OIL/COOLANT submenu, press the button next to the “>>” in the display to move to the BATTERY/HOURS submenu. Select BATTERY for a display of battery voltage. Select HOURS for a display of the number of starts and the running hours. When battery or hours parameters are displayed, pressing the button next to the “<<” will return the display (“BACK”) to the BATTERY/HOURS submenu.

RPM/EXHAUST submenu: From the BATTERY/HOURS submenu, press the button next to the “>>” in the display to move to the RPM/EXHAUST submenu. Select RPM for a display of engine RPM. Select EXHAUST for a display of the (optional) exhaust temperature. When RPM or exhaust parameters are displayed, pressing the button next to the “<<” will return the display (“BACK”) to the RPM/EXHAUST submenu.

ENGINE

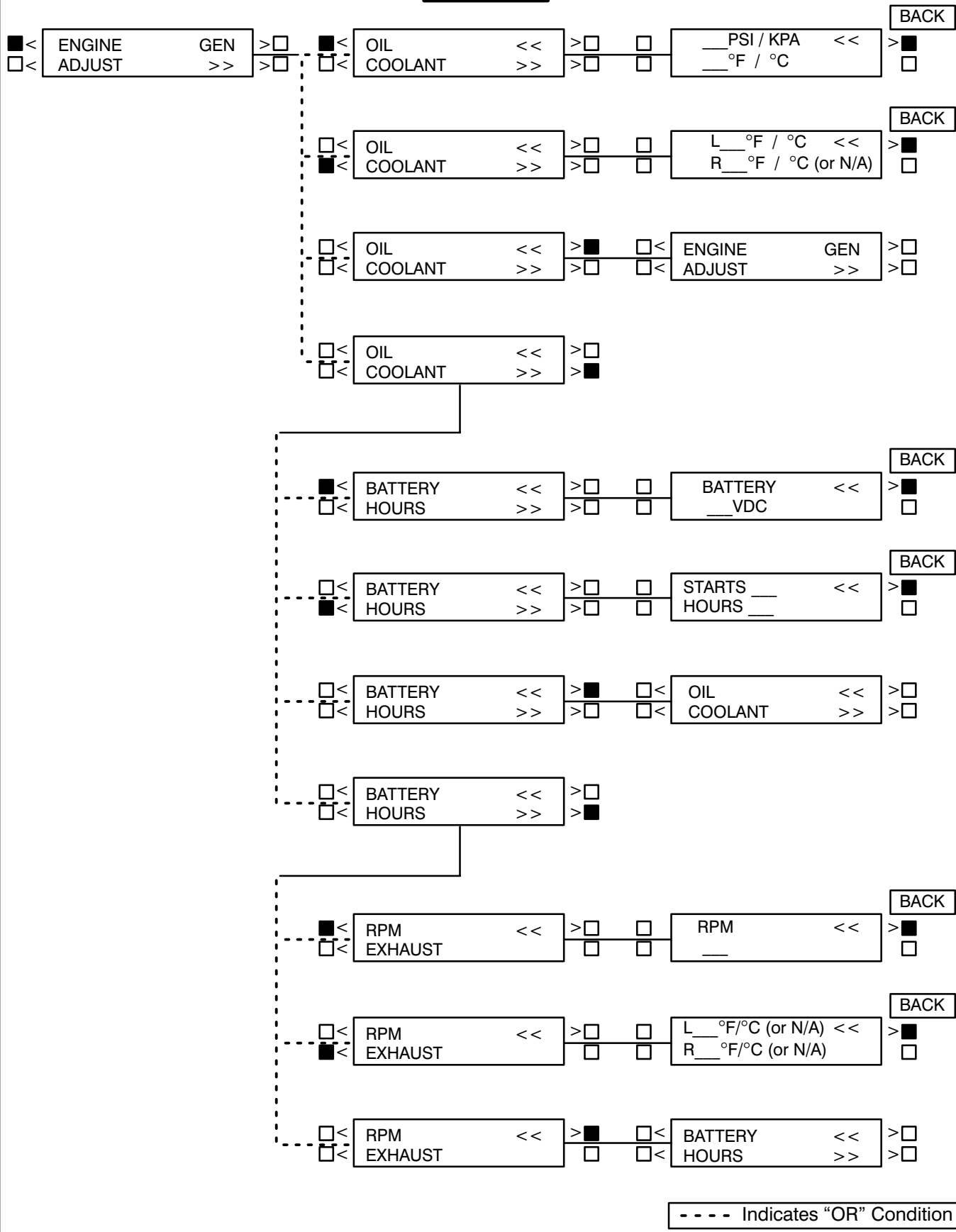

GEN MENU

The facing page shows a block representation of the GEN menu. If you press the button next to the word “GEN” in the display, the first GEN submenu will appear.

As shown in the diagram, the GEN menu has three submenus.

VOLTS/AMPS submenu: This is the first submenu. Select VOLTS for a display of a line-to-line or line-to-neutral selection, or for viewing of the system bus line-to-line voltage. Select line-line or line-neutral for the desired voltage display. Select AMPS for a display of L1, L2, and L3 current in amps. When voltage or current parameters are displayed, pressing the button next to the “<<” will return the display (“BACK”) to the L-L/L-N submenu.

If DELTA is selected in the Initial Start Setup submenu, when selecting VOLTS, the “line-line” or “line-neutral” submenus will not be displayed, only the L12, L23, L31 submenu will be displayed.

POWER / KW HOURS submenu: From the VOLTS/AMPS submenu, press the button next to the “>>” in the display to move to the POWER/KW HOURS submenu. Select POWER for a display of power output in kilowatts and a power factor value. Select KW HOURS for a display of kilowatt hours. When power or kW hours parameters are displayed, pressing the button next to the “<<” will re-

turn the display (“BACK”) to the POWER/KW HOURS submenu.

The PF reading will contain an asterisk if the power factor is leading (for example, *.3PF).

Beginning Version 1.06, N/A is displayed in the PF field when the generator set is not running.

%GOV/REG/FREQUENCY submenu: From the POWER/KW HOURS submenu, press the button next to the “>>” in the display to move to the %GOV/REG/FREQUENCY submenu. Select %GOV/REG for a display of voltage regulator and governor duty cycle (drive) levels in percentage of maximum. Select FREQUENCY for a display of the generator output frequency the bus frequency, or the digital synchroscope. When voltage regulator and governor or frequency parameters are displayed, pressing the button next to the “<<” will return the display (“BACK”) to the %GOV/REG/FREQUENCY submenu.

Bus Frequency (Digital Synchroscope) submenu: When the bus frequency (digital synchroscope) information is displayed, the operator can observe the generator set synchronizing with the system bus. The display indicates bus frequency and number of degrees from synchronous condition (+ indicates faster, – indicates slower). When the generator set is operating within the sync-check window, an asterisk will indicate that the paralleling breaker can be closed.

GEN

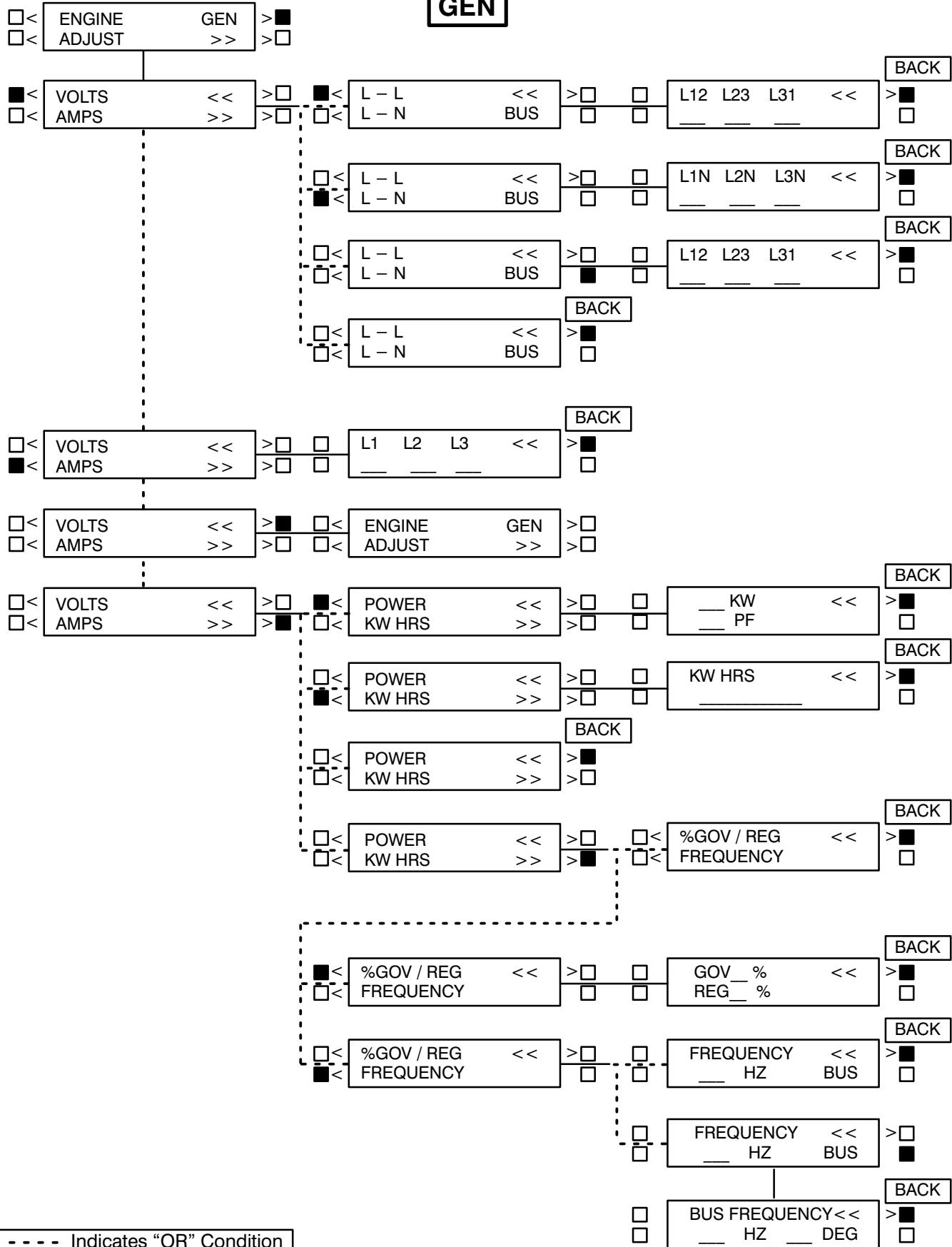

THIS PAGE LEFT INTENTIONALLY BLANK