

# SHOP MANUAL

**KOMATSU-CUMMINS**

**N-855 SERIES**

**DIESEL ENGINE**

ENGINE MODEL      APPLICABLE MACHINE

<b>N-855-C</b>	<b>PC300-1</b>
	<b>PC300-2</b>
	<b>PC300LC-1</b>
	<b>PC300LC-2</b>
<b>NT-855-C</b>	<b>D80A,E-18</b>
	<b>D85A,E,P-18</b>
	<b>D80F-18</b>
	<b>D95S-2</b>
	<b>PC400-1</b>
	<b>PC400LC-1</b>
	<b>W170-2</b>
	<b>W180-1</b>
<b>NTA-855-C</b>	<b>HD320-2</b>
	<b>HD320-3</b>
	<b>WS16S-2</b>
	<b>WS23-1</b>

# CONTENTS

	No. of page
<b>01 GENERAL</b> .....	01-001
<b>11 STRUCTURE AND FUNCTION</b> .....	11-001
<b>12 TESTING AND ADJUSTING</b> .....	12-001
<b>13 DISASSEMBLY AND ASSEMBLY</b> .....	13-001
<b>14 MAINTENANCE STANDARD</b> .....	14-001
<b>15 REPAIR AND REPLACEMENT</b> .....	15-001
<b>19 OTHERS</b> .....	19-001

**LIST OF REVISED PAGES**

The affected pages are indicated by the use of the following marks. It is requested that necessary actions be taken to these pages according to the table below.

Mark	Indication	Action required
○	Page to be newly added	Add
●	Page to be replaced	Replace
( )	Page to be deleted	Discard

Pages having no marks are those previously revised or made additions.

**LIST OF REVISED PAGES**

Mark	Page	Time of revision	Mark	Page	Time of revision	Mark	Page	Time of revision	Mark	Page	Time of revision	Mark	Page	Time of revision
●	00- 1	③	○	00-26	③	●	01-022	③	●	11-006	③	○	11-035	③
●	00- 2	③	○	00-27	③	●	01-023	③	●	11-007	③	○	11-036	③
●	00- 2-1	③	○	00-28	③	●	01-024	③	●	11-008	③	○	11-037	③
○	00- 2-2	③	○	00-29	③	●	01-025	③	●	11-009	③	○	11-038	③
○	00- 2-3	③	○	00-30	③	●	01-026	③	○	11-010	③	○	11-039	③
○	00- 3	③	○	00-31	③	●	01-027	③	○	11-011	③	○	11-041	③
○	00- 4	③				●	01-028	③	○	11-012	③	○	11-042	③
○	00- 5	③				●	01-029	③	○	11-013	③	○	11-043	③
○	00- 6	③	●	01-001	③	●	01-030	③	○	11-014	③	○	11-044	③
○	00- 7	③	●	01-003	③	●	01-031	③	○	11-015	③	○	11-045	③
○	00- 8	③	●	01-004	③		(01-031-1)		○	11-016	③	○	11-046	③
○	00- 9	③		01-005		●	01-032	③	○	11-017	③	○	11-047	③
○	00-10	③		01-006		●	01-033	③	○	11-018	③	○	11-048	③
○	00-11	③	○	01-007	③		(01-033-1)		○	11-019	③	○	11-049	③
○	00-12	③	●	01-008	③		(01-033-2)		○	11-020	③	○	11-050	③
○	00-13	③	●	01-009	③	●	01-034	③	○	11-021	③	○	11-051	③
○	00-14	③	●	01-010	③	●	01-035	③	○	11-022	③	○	11-052	③
○	00-15	③		(01-011)		●	01-036	③	○	11-023	③	○	11-053	③
○	00-16	③	●	01-012	③	○	01-037	③	○	11-024	③	○	11-054	③
○	00-17	③	●	01-013	③	○	01-038	③	○	11-025	③	○	11-055	③
○	00-18	③	●	01-014	③	○	01-039	③	○	11-026	③	○	11-056	③
○	00-19	③	●	01-015	③	○	01-040	③	○	11-027	③	○	11-057	③
○	00-20	③	●	01-016	③	○	01-041	③	○	11-028	③	○	11-058	③
○	00-21	③	●	01-017	③				○	11-029	③	○	11-059	③
○	00-22	③	●	01-018	③	●	11-001	③	○	11-030	③	○	11-060	③
○	00-23	③	●	01-019	③	●	11-003	③	○	11-031	③	○	11-061	③
○	00-24	③	●	01-020	③	○	11-004	③	○	11-032	③	○	11-062	③
○	00-25	③	●	01-021	③	●	11-005	③	○	11-034	③	○	11-063	③

**LIST OF REVISED PAGES**

Mark	Page	Time of revision	Mark	Page	Time of revision	Mark	Page	Time of revision	Mark	Page	Time of revision	Mark	Page	Time of revision
○	11-064	③		(11-211)			(11-503)		●	12-023	③	○	12-064	③
○	11-066	③		(11-212)			(11-504)		●	12-024	③	○	12-065	③
○	11-067	③		(11-213)			(11-505)		●	12-025	③	○	12-066	③
○	11-068	③		(11-214)			(11-506)		●	12-026	③	○	12-067	③
○	11-069	③		(11-215)			(11-507)		●	12-027	③	○	12-068	③
○	11-070	③		(11-216)			(11-508)		●	12-028	③	○	12-069	③
○	11-071	③		(11-301)			(11-509)			(12-028-1)		○	12-070	③
○	11-072	③		(11-302)			(11-510)		●	12-029	③	○	12-071	③
○	11-073	③		(11-303)			(11-511)		●	12-030	③	○	12-072	③
○	11-074	③		(11-304)			(11-512)		●	12-031	③	○	12-073	③
○	11-075	③		(11-305)			(11-513)		●	12-032	③			
○	11-076	③		(11-306)			(11-514)		○	12-033	③			
○	11-077	③		(11-307)			(11-515)		●	12-034	③			
○	11-078	③		(11-308)			(11-601)		●	12-035	③	●	13-001	③
○	11-079	③		(11-309)			(11-602)		●	12-036	③		13-003	
○	11-080	③		(11-310)					●	12-037	③		13-005	
○	11-081	③		(11-311)					○	12-038	③		13-006	
○	11-082	③		(11-312)		●	12-001	③	○	12-039	③		13-007	
○	11-083	③		(11-314)		●	12-003	③	○	12-040	③		13-008	
○	11-084	③		(11-315)		●	12-004	③	○	12-041	③		13-009	
○	11-085	③		(11-401)		●	12-005	③	○	12-042	③		13-010	
○	11-086	③		(11-402)		●	12-006	③	○	12-043	③		13-011	
	(11-101)			(11-403)			(12-007)		○	12-045	③		13-012	
	(11-102)			(11-404)			(12-007-1)		○	12-046	③		13-013	
	(11-103)			(11-405)			(12-007-2)		○	12-047	③		13-014	
	(11-104)			(11-406)		●	12-008	③	○	12-048	③		13-015	
	(11-105)			(11-407)		●	12-009	③	○	12-049	③		13-016	
	(11-106)			(11-408)		●	12-010	③	○	12-050	③		13-017	
	(11-107)			(11-409)		●	12-011	③	○	12-052	③		13-018	
	(11-108)			(11-410)		●	12-012	③	○	12-053	③		13-019	
	(11-201)			(11-411)		●	12-013	③	○	12-054	③		13-020	
	(11-202)			(11-412)		●	12-014	③	○	12-055	③		13-021	
	(11-203)			(11-412-1)		●	12-015	③	○	12-056	③		13-022	
	(11-204)			(11-413)		●	12-016	③	○	12-057	③		13-023	
	(11-205)			(11-414)		●	12-017	③	○	12-058	③		13-024	
	(11-206)			(11-415)		●	12-018	③	○	12-059	③		13-025	
	(11-207)			(11-416)		●	12-019	③	○	12-060	③		13-026	
	(11-208)			(11-417)		●	12-020	③	○	12-061	③		13-027	
	(11-209)			(11-501)		●	12-021	③	○	12-062	③		13-101	
	(11-210)			(11-502)		●	12-022	③	○	12-063	③		13-102	



LIST OF REVISED PAGES

Mark	Page	Time of revision	Mark	Page	Time of revision	Mark	Page	Time of revision	Mark	Page	Time of revision	Mark	Page	Time of revision
	13-103		●	14-001	③	○	15-010	③						
	13-104		●	14-003	③	○	15-011	③						
	13-105		○	14-004	③	○	15-012	③						
	13-106		●	14-005	③	○	15-013	③						
	13-107		●	14-006	③	○	15-014	③						
	13-108		●	14-007	③	○	15-015	③						
	13-109		○	14-008	③	○	15-016	③						
	13-110		●	14-009	③	○	15-017	③						
	13-111		●	14-010	③	○	15-018	③						
	13-112		●	14-011	③	○	15-019	③						
	13-113		●	14-012	③	○	15-020	③						
	13-114		●	14-013	③	○	15-021	③						
	13-115	①	●	14-014	③	○	15-022	③						
	13-116		●	14-015	③	○	15-023	③						
	13-117		●	14-016	③	○	15-024	③						
	13-118		●	14-017	③	○	15-025	③						
	13-119		●	14-018	③	○	15-026	③						
	13-120		●	14-019	③	○	15-027	③						
	13-121		●	14-020	③	○	15-028	③						
	13-122		●	14-021	③									
	13-123		●	14-022	③									
	13-124		○	14-023	③	●	19-001	③						
	13-125		●	14-024	③		19-003							
	13-126			(14-025)			19-004							
	13-127			(14-026)			19-005							
	13-128			(14-027)			19-006							
	13-129			(14-028)										
	13-130			(14-029)										
	13-131			(14-031)										
	13-132			(14-032)										
	13-133													
	13-134													
	13-135		○	15-001	③									
	13-202		○	15-003	③									
	13-203		○	15-004	③									
	13-204		○	15-005	③									
	13-205		○	15-006	③									
	13-206		○	15-007	③									
	13-207		○	15-008	③									
			○	15-009	③									



## IMPORTANT SAFETY NOTICE

Proper service and repair is extremely important for the safe operation of your machine. The service and repair techniques recommended by Komatsu and described in this manual are both effective and safe methods of operation. Some of these operations require the use of tools specially designed by Komatsu for the purpose.

To prevent injury to workers, the symbols  and  are used to mark safety precautions in this manual. The cautions accompanying these symbols should always be followed carefully. If any dangerous situation arises or may possibly arise, first consider safety, and take the necessary actions to deal with the situation.



## SAFETY

### GENERAL PRECAUTIONS

Mistakes in operation are extremely dangerous. Read the Operation and Maintenance Manual carefully BEFORE operating the machine.

1. Before carrying out any greasing or repairs, read all the precautions given on the decals which are fixed to the machine.
2. When carrying out any operation, always wear safety shoes and helmet. Do not wear loose work clothes, or clothes with buttons missing.
  - Always wear safety glasses when hitting parts with a hammer.
  - Always wear safety glasses when grinding parts with a grinder, etc.
3. If welding repairs are needed, always have a trained, experienced welder carry out the work. When carrying out welding work, always wear welding gloves, apron, glasses, cap and other clothes suited for welding work.
4. When carrying out any operation with two or more workers, always agree on the operating procedure before starting. Always inform your fellow workers before starting any step of the operation. Before starting work, hang UNDER REPAIR signs on the controls in the operator's compartment.
5. Keep all tools in good condition and learn the correct way to use them.

6. Decide a place in the repair workshop to keep tools and removed parts. Always keep the tools and parts in their correct places. Always keep the work area clean and make sure that there is no dirt or oil on the floor. Smoke only in the areas provided for smoking. Never smoke while working.

### PREPARATIONS FOR WORK

7. Before adding oil or making any repairs, park the machine on hard, level ground, and block the wheels or tracks to prevent the machine from moving.
8. Before starting work, lower blade, ripper, bucket or any other work equipment to the ground. If this is not possible, insert the safety pin or use blocks to prevent the work equipment from falling. In addition, be sure to lock all the control levers and hang warning signs on them.
9. When disassembling or assembling, support the machine with blocks, jacks or stands before starting work.
10. Remove all mud and oil from the steps or other places used to get on and off the machine. Always use the handrails, ladders or steps when getting on or off the machine. Never jump on or off the machine. If it is impossible to use the handrails, ladders or steps, use a stand to provide safe footing.

## PRECAUTIONS DURING WORK

11. When removing the oil filler cap, drain plug or hydraulic pressure measuring plugs, loosen them slowly to prevent the oil from spurting out.  
Before disconnecting or removing components of the oil, water or air circuits, first remove the pressure completely from the circuit.
12. The water and oil in the circuits are hot when the engine is stopped, so be careful not to get burned.  
Wait for the oil and water to cool before carrying out any work on the oil or water circuits.
13. Before starting work, remove the leads from the battery. Always remove the lead from the negative (—) terminal first.
14. When raising heavy components, use a hoist or crane.  
Check that the wire rope, chains and hooks are free from damage.  
Always use lifting equipment which has ample capacity.  
Install the lifting equipment at the correct places. Use a hoist or crane and operate slowly to prevent the component from hitting any other part. Do not work with any part still raised by the hoist or crane.
15. When removing covers which are under internal pressure or under pressure from a spring, always leave two bolts in position on opposite sides. Slowly release the pressure, then slowly loosen the bolts to remove.
16. When removing components, be careful not to break or damage the wiring. Damaged wiring may cause electrical fires.
17. When removing piping, stop the fuel or oil from spilling out. If any fuel or oil drips on to the floor, wipe it up immediately. Fuel or oil on the floor can cause you to slip, or can even start fires.
18. As a general rule, do not use gasoline to wash parts. In particular, use only the minimum of gasoline when washing electrical parts.
19. Be sure to assemble all parts again in their original places.  
Replace any damaged parts with new parts.
  - When installing hoses and wires, be sure that they will not be damaged by contact with other parts when the machine is being operated.
20. When installing high pressure hoses, make sure that they are not twisted. Damaged tubes are dangerous, so be extremely careful when installing tubes for high pressure circuits. Also, check that connecting parts are correctly installed.
21. When assembling or installing parts, always use the specified tightening torques. When installing protective parts such as guards, or parts which vibrate violently or rotate at high speed, be particularly careful to check that they are installed correctly.
22. When aligning two holes, never insert your fingers or hand. Be careful not to get your fingers caught in a hole.
23. When measuring hydraulic pressure, check that the measuring tool is correctly assembled before taking any measurements.
24. Take care when removing or installing the tracks of track-type machines.  
When removing the track, the track separates suddenly, so never let anyone stand at either end of the track.

---

## FOREWORD

---

This shop manual has been prepared as an aid to improve the quality of repairs by giving the serviceman an accurate understanding of the product and by showing him the correct way to perform repairs and make judgements. Make sure you understand the contents of this manual and use it to full effect at every opportunity.

This shop manual mainly contains the necessary technical information for operations performed in a service workshop.

For ease of understanding, the manual is divided into chapters for each main group of components; these chapters are further divided into the following sections.

### **STRUCTURE AND FUNCTION**

This section explains the structure and function of each component. It serves not only to give an understanding of the structure, but also serves as reference material for troubleshooting.

### **TESTING AND ADJUSTING**

This section explains checks to be made before and after performing repairs, as well as adjustments to be made at completion of the checks and repairs.

Troubleshooting charts correlating "Problems" to "Causes" are also included in this section.

### **DISASSEMBLY AND ASSEMBLY**

This section explains the order to be followed when removing, installing, disassembling or assembling each component, as well as precautions to be taken for these operations.

### **MAINTENANCE STANDARD**

This section gives the judgement standards when inspecting disassembled parts.

### **NOTICE**

**The specifications contained in this shop manual are subject to change at any time and without any advance notice. Contact your KOMATSU distributor for the latest information.**



# HOW TO READ THE SHOP MANUAL

## VOLUMES

Shop manuals are issued as a guide to carrying out repairs. They are divided as follows:

**Chassis volume:** Issued for every machine model

**Engine volume:** Issued for each engine series

**Electrical volume** : } Each issued as one  
**Attachments volume** : } volume to cover all  
models

These various volumes are designed to avoid duplicating the same information. Therefore to deal with all repairs for any model, it is necessary that chassis, engine, electrical and attachment volumes are ready.

## DISTRIBUTION AND UPDATING

Any additions, amendments or other changes will be sent to KOMATSU distributors. Get the most up-to-date information before you start any work.

## FILING METHOD

- See the page number on the bottom of the page. File the pages in correct order.
- Following examples show how to read the page number.

Example 1 (Chassis volume):

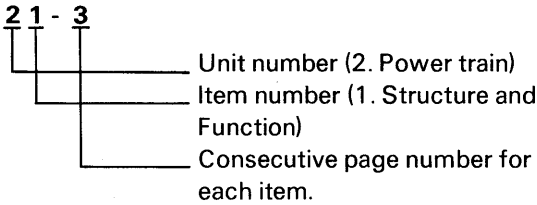

Example 2 (Engine volume):

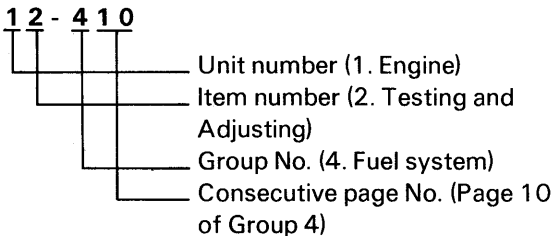

- Additional pages: Additional pages are indicated by a hyphen (-) and number after the page number. File as in the example.

Example:

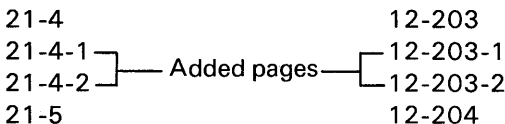

## REVISED EDITION MARK (①②③....)

When a manual is revised, an edition mark is recorded on the bottom outside corner of the pages.

## REVISIONS

Revised pages are shown at the LIST OF REVISED PAGES on the between the title page and SAFETY page.

## SYMBOLS

So that the shop manual can be of ample practical use, important places for safety and quality are marked with the following symbols.

Symbol	Item	Remarks
	Safety	Special safety precautions are necessary when performing the work.
		Extra special safety precautions are necessary when performing the work because it is under internal pressure.
	Caution	Special technical precautions or other precautions for preserving standards are necessary when performing the work.
	Weight	Weight of parts or systems. Caution necessary when selecting hoisting wire, or when working posture is important, etc.
	Tightening torque	Places that require special attention for the tightening torque during assembly.
	Coat	Places to be coated with adhesives and lubricants etc.
	Oil, water	Places where oil, water or fuel must be added, and the capacity.
	Drain	Places where oil or water must be drained, and quantity to be drained.

**NETWORK (Disassembly and assembly relationship drawings)**

In the shop manual the following network drawings show relationship between work items and sequence for assembly and disassembly.

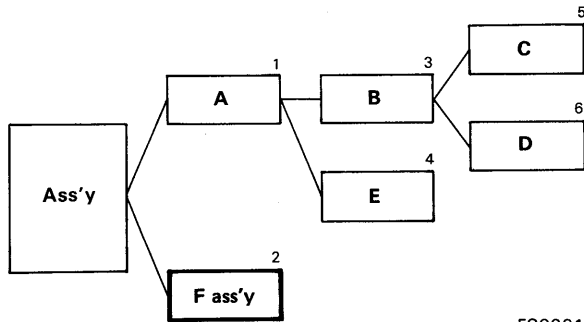

FS0001

In this network the sequence of disassembly is marked on the top right of each work item so that handling can be easily understood. For example, when taking **D** of the Ass'y follow the sequence **A** → **B** → **D**, when removing **E** follow the sequence **A** → **E**.

**F ass'y** indicates a further separate disassembly, and indicates the existence of a previous work network. For assembly the sequence is shown using the same kind of network.

**TROUBLESHOOTING CHART**

As shown below, the symptoms relating to a particular trouble are described in the line designated "Problems". The probable cause of the trouble is then marked under the "Causes" column.

Example:  
Symptom: Reduced tractive power or slow travel speed.

Problems	Causes		
	Oil leaks in torque converter	Air suction in the hydraulic pump	
Torque converter oil pressure gauge shows lower than normal pressure. (normal 3 – 4.8 kg/cm <sup>2</sup> )	○	○	○
Transmission oil pressure gauge shows lower than normal pressure. (normal 20 – 23 kg/cm <sup>2</sup> )		○	
	○		

**MAINTENANCE STANDARD**

**Standard size, Tolerance**

The dimensions of finished parts each differ a little. Therefore, when determining the finished dimensions of parts, a dimension that will be standard is determined provisionally, then the difference allowed from it is indicated. The former is called the standard size, and the latter the tolerance.

The way to show this is by a plus or a minus sign with the tolerance in smaller numerals to the right of the standard size.

Example:  $120 \begin{smallmatrix} -0.026 \\ -0.126 \end{smallmatrix}$   
(It equals 119.874 – 119.978 mm)

Moreover, when expressing the dimensions of a hole and the shaft that goes inside it, for the sake of convenience, the standard size for the hole and the shaft are usually taken as the same, and the tolerances changed to indicate the tightness of the fit. For example, the fit of a revolving shaft is indicated as follows, and is shown in the drawing.

Hole:  $60 \begin{smallmatrix} +0.046 \\ 0 \end{smallmatrix}$       Shaft:  $60 \begin{smallmatrix} -0.030 \\ -0.076 \end{smallmatrix}$

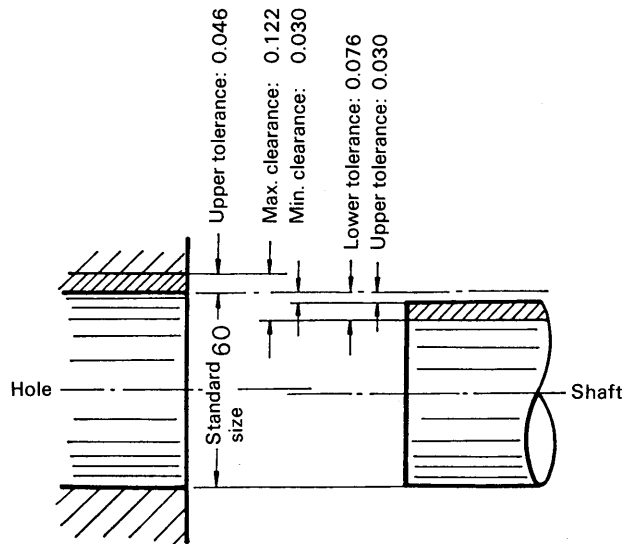

FS0002

**HOW TO READ THE SHOP MANUAL**

---

**Standard size**

This is the standard value at the time of design.

**Repair limit**

This is the limit in dimensions which the part can be used. When parts exceed the repair limit, they must be repaired or replaced as specified.

Example:

Unit: mm

No.	Check item	Criteria		Remedy
		Standard size	Repair limit	

**Standard clearance**

This is the clearance between new parts after assembly. It is recorded as a range between minimum clearance and maximum clearance. The clearance is adjusted to this value.

**Clearance limit**

This is the maximum clearance allowed. When the clearance exceeds the clearance limit, the parts must be repaired or replaced as specified.

Example:

Unit: mm

No.	Check item	Criteria				Remedy	
		Standard size	Tolerance		Standard clearance		Clearance limit
			Shaft	Hole			

## PRECAUTIONS FOR DISASSEMBLY AND ASSEMBLY

### 1. PREPARATIONS BEFORE DISASSEMBLY

#### 1. Washing before taking a machine into the repair shop

Thoroughly wash the machine to remove sand, mud and dust before taking it into the shop. Taking a dirty machine into the shop will decrease work efficiency, cause damage to parts, and increase the intrusion of dust and dirt into the machine when it is reassembled.

#### 2. Checking the machine before disassembly

Before disassembly, study the entire disassembly procedure from beginning to end in the reference materials, and carefully check and record the items listed below. This will help to save unnecessary disassembly and parts costs. It will also give clues on how to prevent recurrence of the trouble.

- Machine model, serial number and service meter reading.
- Reason for disassembly. (Symptoms, locations, and cause of trouble)
- Any dirty air cleaner elements or air leakage.
- Properties of fuel used, clogging of fuel filter elements, water mixed in fuel, and leaky or constricted fuel pipes.
- Oil capacities, dirtiness of oils (viscosity, color, and any impurities), water mixed in oil, oil leakage, and any clogging of oil filter elements.
- Tension of the V-belt and tracks.
- Any damaged parts or loose bolts.

#### 3. Preparation for disassembly

Prepare the required facilities, tools, and space for the disassembly work and rack space for storing the disassembled parts. Make sure that they are all clean.

### 2. PRECAUTIONS FOR DISASSEMBLY AND REASSEMBLY

#### 1. During disassembly

- 1) If the disassembly involves draining oil or lubricants, have containers of suitable capacity on hand. Do not spill any oil or lubricants on the floor.
- 2) Mark the parts clearly to prevent confusion at the time of reassembly.
- 3) For disassembly of certain designated parts, use only the special tool prescribed for that purpose.
- 4) When, after removal of fastening nuts and bolts, a part still can not be removed, never force it. Instead, investigate and correct the cause.
- 5) Maintain disassembled parts in good order for storage, paying special care not to confuse parts that appear similar. Tag them or mark with ink if necessary.
- 6) Store standard parts such as bolts and nuts with reference to where they are to be used and in a manner that will prevent loss.

#### 2. During reassembly

- 1) Thoroughly clean and examine all parts before reassembly. Repair any scratched or dented surfaces.
  - ★ Foreign matter is especially damaging to sliding surfaces, and will greatly decrease their service life.
- 2) Clean new parts to remove any rust preventative coating.  
**Solvent:** Light oil or trichloroethane
- 3) Carefully align any match marks provided.
- 4) Use a press or press-fitting tool to assemble bearings, bushings and oil seals.

#### 3. Checks and inspections during disassembly/reassembly

- 1) During disassembly, watch carefully for evidence of seizing, interference, or improper contact of sliding parts.
- 2) Measure and record end clearances, gear backlashes, protrusions, and the like during the disassembly/reassembly. Quite often they cannot be measured afterwards.

**PRECAUTIONS FOR DISASSEMBLY AND ASSEMBLY**

**3. DETERGENTS**

**1. Precautions for cleaning**

- 1) Thoroughly clean disassembled parts and group them by unit for storage. Be especially sure to remove sludge from oil holes and pipes.
- 2) Never use dirty solvents to clean important parts.
- 3) Take extreme care with special chemical agents. Observe the manufacturer's handling instructions and take measures to prevent the agent from coming into contact with your skin or eyes.

**2. Selection of detergents**

Parts	Detergents
Ordinary parts	Kerosene, light oil, or trichloroethane
Finely machined parts (Bearings etc.)	Clean kerosene or neutral dehydrated light oil
Large castings (Cylinder head, cylinder block etc.)	Alkaline detergent, PH10 – 12. (Immerse in 50 – 70°C detergent for 5 – 10 minutes. Then rinse thoroughly with water.)

**3. Detergents for washing rubber parts (O-rings, oil seals etc.)**

Detergents	Rubber			
	Nitrile rubber	Ester rubber	Silicon rubber	Fluorine rubber
Trichloroethane	○	○	○	○
Trichloroethylene	○	X	X	○
Gasoline	X	X	X	○
Thinner	X	X	X	X
Light oil	○	○	X	○
Steam	○	X	○	○

○: Immersion allowed for a short time only  
 X: Detergent detrimental to rubber

**4. NUTS AND BOLTS**

Unless otherwise specified in the DISASSEMBLY AND ASSEMBLY, tighten all bolts to a torque of page 00-29.

- 1) Use bolts having the exact length required for the parts they are to join.  
 If too long, the bolt presses against the bottom of the tapped hole; this pressure makes proper tightening impossible. If too short, the bolt lacks the number of threads necessary to hold the parts together.
- 2) Tighten each nut and bolt to the specified torque.
- 3) Tighten bolts evenly and in order.

Tighten mutually opposing bolts alternately.

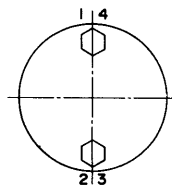

Tighten in turn on opposite sides.

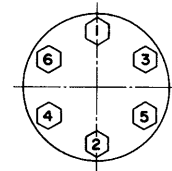

Tighten from the center outwards and on alternate sides.

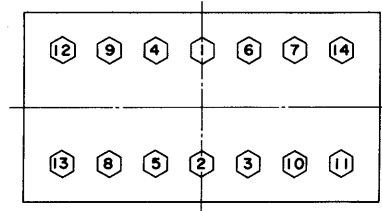

FS0003

- 4) The Template Method is prescribed for tightening bolts on certain specific parts of the engine.

The Template Method obtains good fittings of bolts with their seats and of bearings with their races to ensure uniform overall tightening. The bolts are tightened in stages, then loosened, and then tightened once more.

**5. HANDLING LOCKING DEVICES**

Nuts and bolts which cannot be checked visually from the outside or which are located in vital areas must be firmly locked into position with wires, cotter pins, and lock washers. Never reuse these locking devices.

**1. Lock wire**

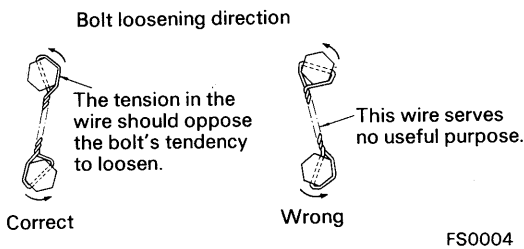

**2. Cotter pin**

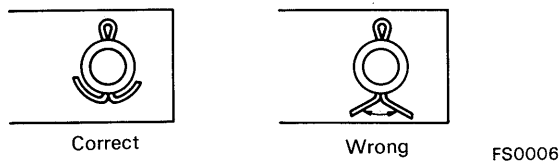
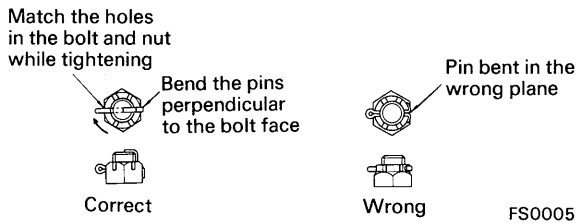

- Bend the head and ends of the cotter pin upwards as far as possible.

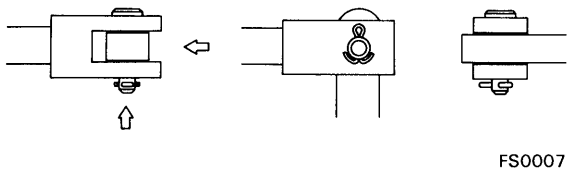

**3. Lock washer**

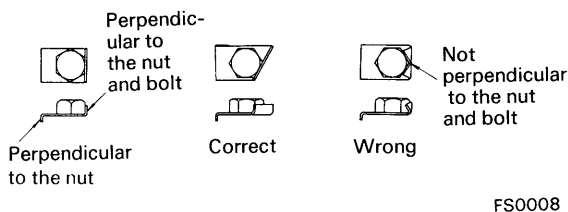

**4. Thread tightener**

- 1) Wash and degrease the bolt and bolt hole with trichloroethylene and dry. Coat the bolt threads with two or three drops of thread tightener and tighten the bolts.
- 2) After an hour had passed, the bolt cannot be loosened or tightened any further. If retightening becomes necessary, the bolt must be completely removed, the old thread tightener removed, and a new coat applied.

**6. PRECAUTIONS FOR PRESS-FITTING**

- Coat the surfaces of the parts to be press-fitted with anti-friction grease (molybdenum disulfide) – unless they are tapered.
- For taper spline-to-serration fittings
  - 1) Check that the splines and serrations are free from dust, burr, dents and indentations.
  - 2) Insert and align the splines and serrations by hand before press-fitting the shaft into the hole.
  - 3) If the spline-serration assembly is loose, disassemble and examine for wear. Replace worn parts with new ones.

**7. PRECAUTIONS FOR ASSEMBLING THE PIN AND SHAFT**

Before reassembling the pin and shaft, check the positions of the locking device and fastening device on the other side. This is especially important when the shaft is retracted from the inside of the hole as illustrated in the accompanying diagram. To ensure proper reassembly, make sure that the lock pin holes coincide.

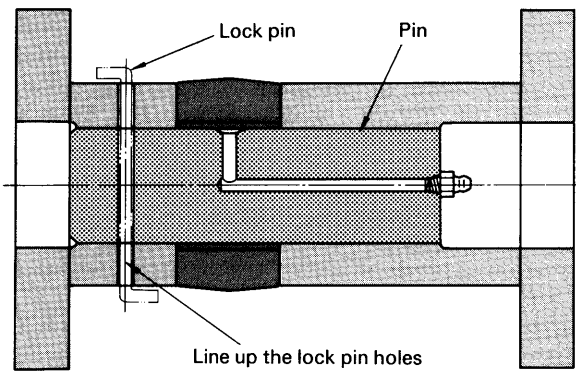

FS0009

**2. Push-puller**

When the screw of the push-puller does not reach the surface of the part to be pushed, insert a spacer. It is also a good idea to insert a plate to prevent the head of the screw from damaging the part.

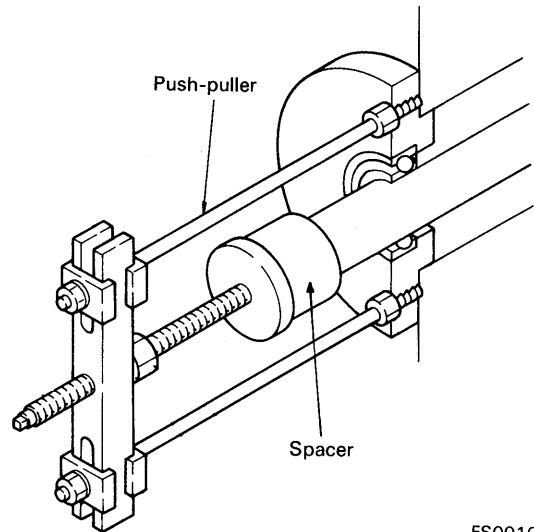

FS0010

**8. SERVICE TOOLS**

**1. Gear puller**

Fit the gear puller over the gear or bearing and tighten the bolt on the gear puller to remove the part from the shaft.

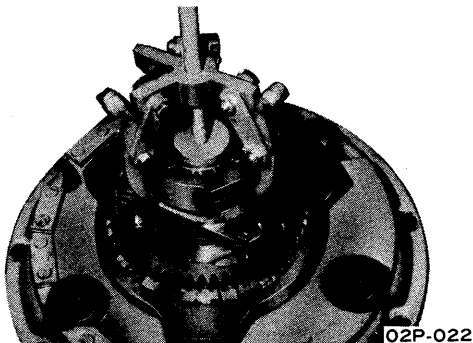

02P-022

**3. Bearing coupler**

This can be used two ways:

- 1) When the bottom of the hole is strong enough to withstand the applied force.
- 2) When the bottom of the hole is not strong enough to withstand the applied force.

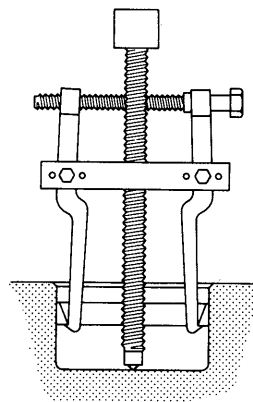

FS0011

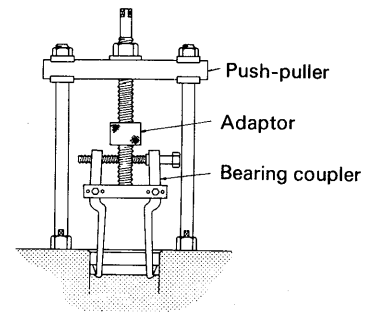

FS0012

**4. Bearing separator**

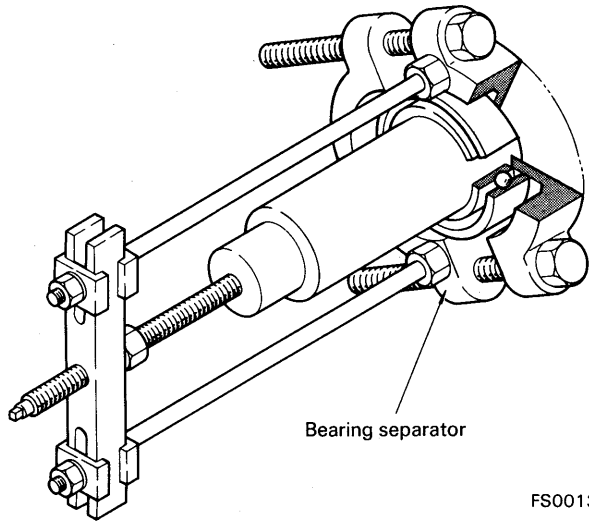

FS0013

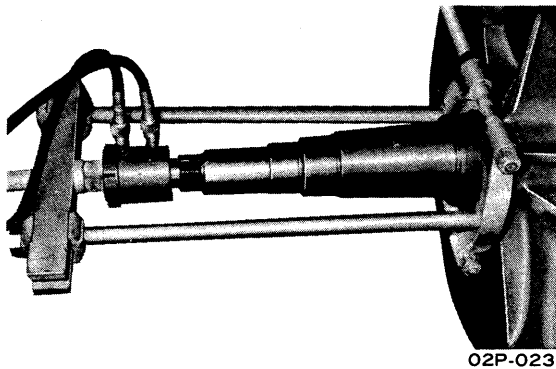

02P-023

**5. Hook wrench**

A hook wrench has a claw which hooks into the turning sockets of round nuts. The wrench size is defined by the outer diameter of the round nut turned. The accompanying figure shows a hook wrench designed for use with round nuts of two different sizes.

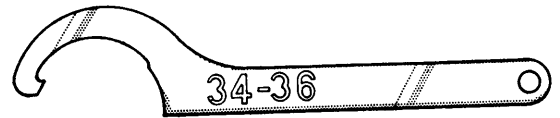

FS0014

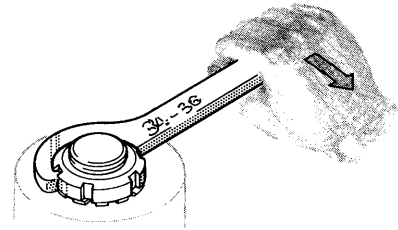

FS0015

**Removal and Installation of the Sprocket Wheel**

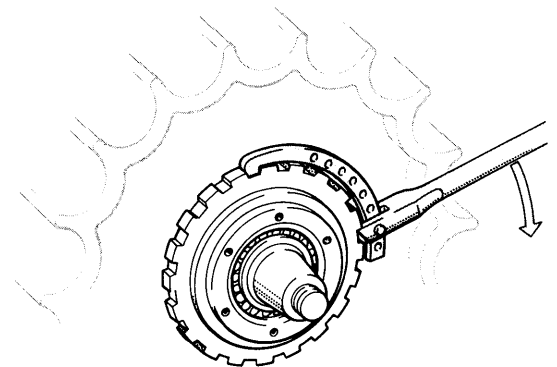

FS0016



**9. CLEARANCE ADJUSTMENTS**

Store each set of shims or washers so that they can be installed in their original condition at the time of reassembly.

**10. LINK RODS**

- 1) If it is necessary to change the length of the link rod in order to remove it, first record the original length so that the rod can be easily reassembled in its original condition.
- 2) Remove the link rod at the pins.

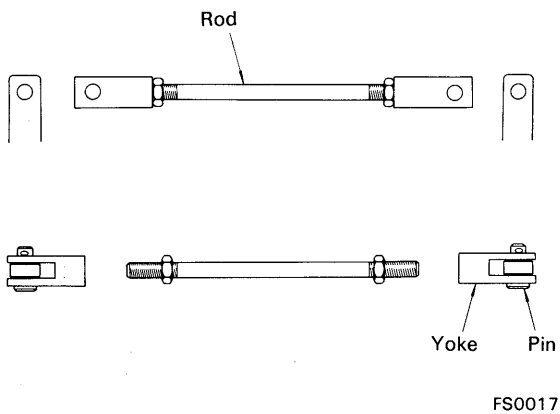

**12. CENTERING**

Centering is very important for interfaces in the power train — for example, between the engine and the transmission and between the bevel gear shaft and the final drives. Incorrect centering only increases the stresses acting on the turning parts, so always make sure that the deviation is within the specified limits.

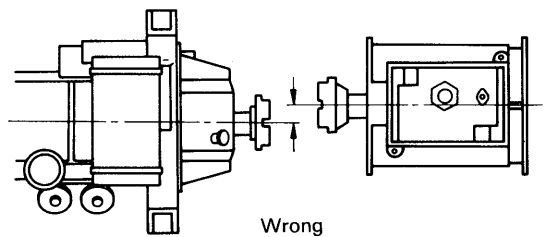
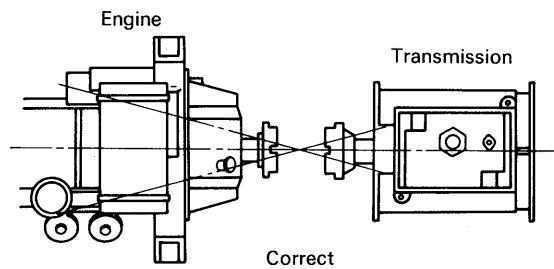
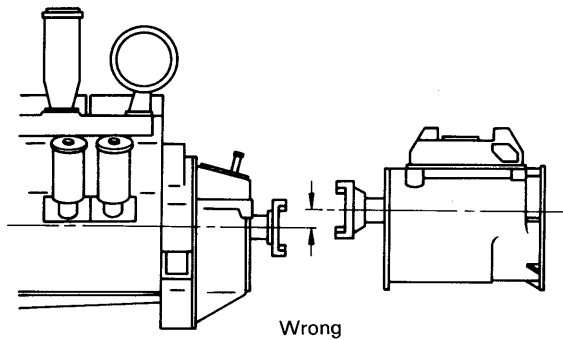
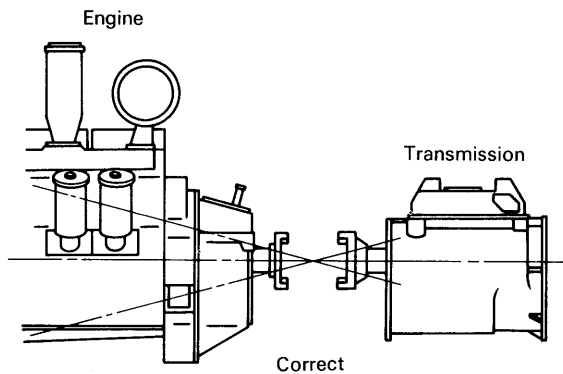

**11. SHIMS AND WASHERS**

- 1) Shims are used to center the engine and adjust the action of the bevel gears. Handle very carefully as they get deformed easily.
- 2) Record the numbers and positions to speed adjustment after reinstallation.
- 3) Do not reuse any shims or washers that are deteriorated, damaged, bent or deformed.
- 4) Insert thin shims between thicker ones.

FS0018

## MEASURING INSTRUCTIONS

### PREPARATIONS BEFORE CHECKING

#### 1. Cleaning of parts

Wash parts to be checked. Special care should be paid to thoroughly remove dust and dirt from the surfaces on which measurements are to be made so that possible errors can be eliminated.

#### 2. Minor repair of part surfaces

Remove scratches, dents and rust from parts to be checked. If the surface are rough, the measurements will be inaccurate. When smoothing any surface, be careful not to use an oilstone or sand paper coarser than the finished surface.

#### 3. Preparation of measuring tools

Clean the tools and thoroughly remove dust and dirt from the surfaces which contact parts. Check the tools for proper function and zero-point adjustment. Remedy any abnormality.

#### 4. Maintenance of measuring tools

Handle all tools with sufficient care and do not subject them to unreasonable force or shocks which can affect their delicate construction. Periodically check the tools for accuracy and, if necessary, calibrate them. Put the tools back into their cases and return them to their fixed storage locations whenever not in use. It is recommended to assign a person to be responsible for the proper storage of measuring tools.

### MEASURING TOOLS

- Repeat each measurement two or three times to eliminate possible errors. Further repetition will be necessary, if there is a large variation in the readings.
- When measuring the inside or outside diameter of a cylindrical object, take two readings with the measuring device put in two directions at right angles to each other. Repeat this at several points along the overall length of the object.
- Along eye-measurement below the unit of a scale may be used for making a comparison between two approximately equal measurements, the accuracy of such eye-measurements should not be considered as reliable.
- At the start of each measurement, select a measuring device having an accuracy appropriate for judging whether the measurement reaches its allowable limit.

### BLOCK GAUGES

- To bring two blocks into contact, wash each block with benzene to remove rust-preventing oil and wipe with a clean cotton cloth. Put one block on the other, causing a sliding or twisting movement between the two.
- If the contact between two blocks feels rough, apply a fine-grade oilstone to the blocks along their edges. (Do not try to rub the contact surface of the blocks.)
- Do not leave the blocks in contact for a long time. Long-time contact will make the blocks difficult to separate or cause black rust to appear on the contact surfaces.
- When separating two blocks, slide or twist them. Do not try to pull them apart, by force or strike them with a mallet.
- When storing a block gauge, wipe off moisture, dirt and fingerprints, coat with a rust-preventing lubricant such as vaseline, and put the gauge back in its case.

### VERNIER CALIPERS

- At the start of measurement, close the jaws and check that there is no clearance (due to wear) between the jaws and that the "zero" point of the graduation is in exact alignment with the "zero" point of the vernier scale.
- Measuring an outer diameter

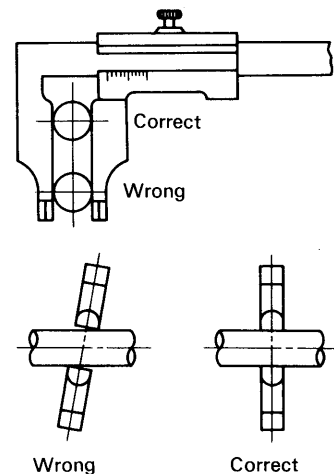

## MEASURING INSTRUCTIONS

### ● Measuring an inner diameter

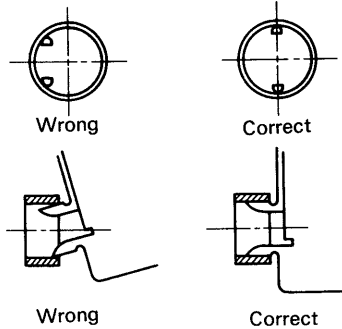

FS0020

### ● Measuring a depth

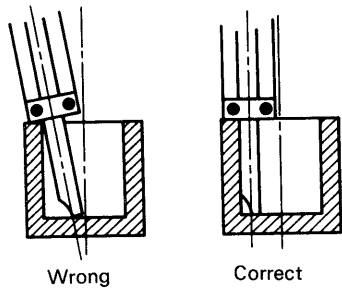

FS0021

## MICROMETERS

- Put the anvil onto an object at a right angle and turn in the spindle until it comes into contact with the object. Rotate the ratchet stop until there are two or three idle rotations, then read the measurement.
- When reading a measurement, keep your eyes at a right angle to the graduation on the sleeve.
- To turn back the spindle, rotate the thimble with your fingers.

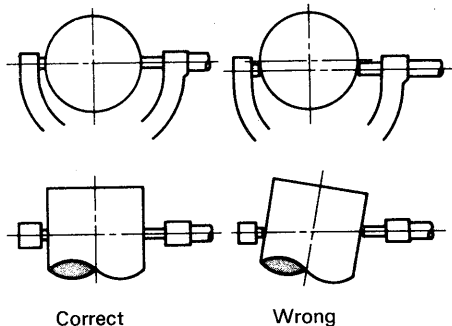

FS0022

- When storing a micrometer, leave a slight clearance between the anvil and the spindle.

## DIAL GAUGES

- Carefully put the gauge contact-point on a surface to be measured to protect the delicate gauge against shock.
- Set the zero-point of the gauge with care to keep the movement of the contact-point within its stroke during measurement.
- Careless setting of the zero-point may cause the spindle to retract or extend to its limit, thus making measurement impossible.
- The measurements of the dial gauge are accompanied by relatively large errors because minute variations of the contact-point (and accompanying errors) are indicated by the dial pointer through an expanding mechanism using gears. The reliability of eye measurements can not be assured below the minimum unit on the scale.
- **Measuring protrusions, depressions or steps**  
Set the zero-point so that vertical movement of the probe does not exceed its stroke limits, and slide the base of the gauge on a flat surface.

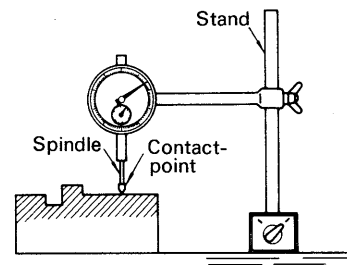

FS0023

### ● Measuring bending

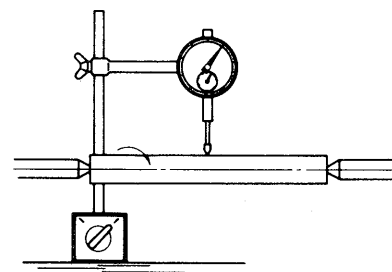

FS0024

Read the Total Indicator Reading (T.I.R.) while moving the object back and forth or vertically. Turn the object one complete rotation and read the difference between the maximum and minimum indications of the gauge pointer.

**MEASURING INSTRUCTIONS**

● **Measuring end play, looseness or deviation**

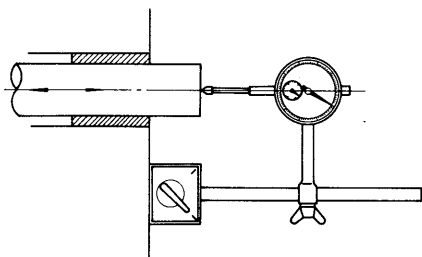

FS0025

Read the T.I.R. while moving the object back and forth or vertically.

● **Measuring face runout or radial runout**

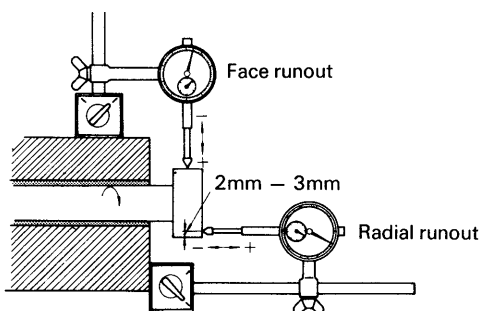

FS0026

- 1) Read runout at six or more positions during one complete rotation of the object.
- 2) At the start of each measurement, set the zero-point at the middle of the assumable range of the spindle movement. Be careful not to confuse positive and negative readings of runout.

	Face runout	Radial runout
When the pointer is to the right of "0"	+	-
When the pointer is to the left of "0"	-	+

- 3) When measuring face runout, place the contact-point on the object along a circle 2 or 3 mm smaller in diameter than the outside diameter of the object.

● **Measuring gear backlash**

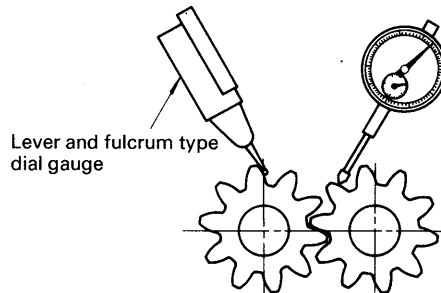

FS0027

- 1) Fully mesh one of two gears and place the dial gauge contact-point on a tooth of the other gear. Swing the free gear within the limits of its play in the rotational directions, and read the T.I.R.
- 2) Use of the lever and fulcrum type dial gauge is recommended for this purpose as the contact-point placed on the gear is moved tangentially to the gear pitch circle.
- 3) The lever and fulcrum type dial gauge is suitable for use in a narrow space or for a special measurement which requires placing the contact-point on an object at an angle to the spindle of the gauge.  
Since the contact-point of this type of gauge has a very narrow measuring range (usually 3 mm or less), the contact-point should be carefully checked for contact with the object during measurement.

**CYLINDER GAUGES**

- Install a contact-point having a length approximately equal to the cylinder bore to the measured on the cylinder gauge. Set the zero-point of the test indicator to the bore diameter of the standard cylinder measured with a reference ring gauge or a micrometer.

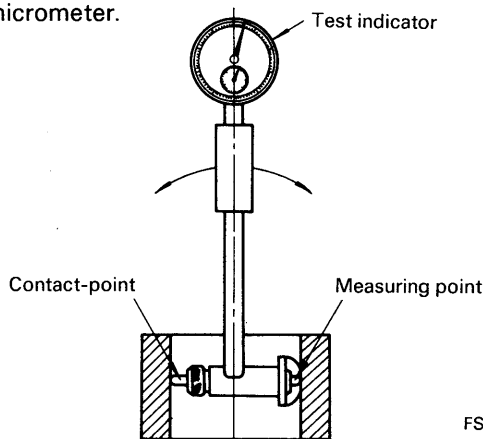

FS0028