

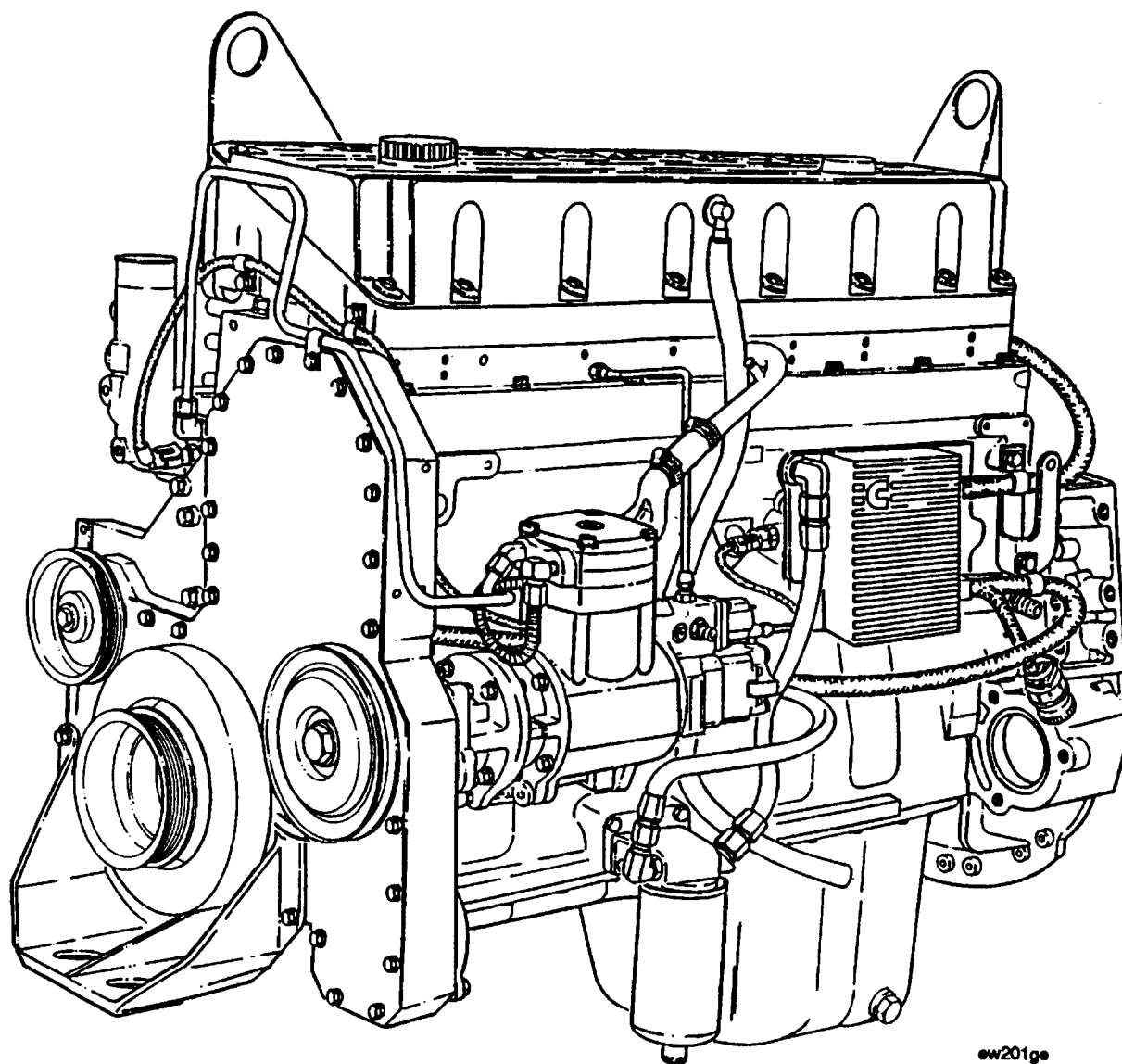

Shop Manual M11 Series Engines



ew201ge

Foreword

This manual contains complete rebuild specifications and information for the M11 model engines, and all associated components manufactured by Cummins Engine Company, Inc. A listing of accessory and component suppliers' addresses and telephone numbers is located in Section C. Suppliers can be contacted directly for any information **not** covered in this manual.

Read and follow all safety instructions. Refer to the WARNING in the General Safety Instructions in this section.

The repair procedures in this manual are based on the engine being installed on an approved engine stand. Some rebuild procedures require the use of special service tools. Make sure the correct tools are used as described in the procedures.

When a specific brand name, number, or special tool is referenced in this manual, an equivalent product can be used in place of the recommended item.

A series of specific service manuals (Troubleshooting and Repair, Specifications, Alternative Repair, and so on.) are available and can be ordered by filling out and mailing the Literature Order Form located in the Service Literature Section L.

Reporting of errors, omissions, and recommendations for improving this publication by the user is encouraged. Please use the postage paid, self-addressed Literature Survey Form in the back of this manual for communicating your comments.

The specifications and rebuild information in this manual is based on the information in effect at the time of printing. Cummins Engine Company, Inc. reserves the right to make any changes at any time without obligation. If differences are found between your engine and the information in this manual, contact a Cummins Authorized Repair Location, a Cummins Division Office, or the factory.

The latest technology and the highest quality components are used to manufacture Cummins engines. When replacement parts are needed, we recommend using only genuine Cummins or ReCon® exchange parts. These parts can be identified by the following trademarks:



Table of Contents

	Section
Introduction	i
Engine Identification.....	E
Engine Disassembly and Assembly – Group 00	0
Cylinder Block – Group 01	1
Cylinder Head – Group 02	2
Rocker Levers – Group 03.....	3
Cam Followers – Group 04.....	4
Fuel System – Group 05.....	5
Injectors and Fuel Lines – Group 06.....	6
Lubricating Oil System – Group 07.....	7
Cooling System – Group 08	8
Drive Units – Group 09.....	9
Air Intake System – Group 10.....	10
Exhaust System – Group 11.....	11
Air Equipment – Group 12.....	12
Electrical Equipment – Group 13	13
Engine Testing – Group 14.....	14
Instruments and Controls – Group 15.....	15
Mounting Adaptations – Group 16	16
Specifications – Group 18	V
Vehicle Braking – Group 20.....	20
Service Literature	L
Component Manufacturers: Names and Addresses	C
Index	X

Cummins' 22-Group System Exploded Diagram

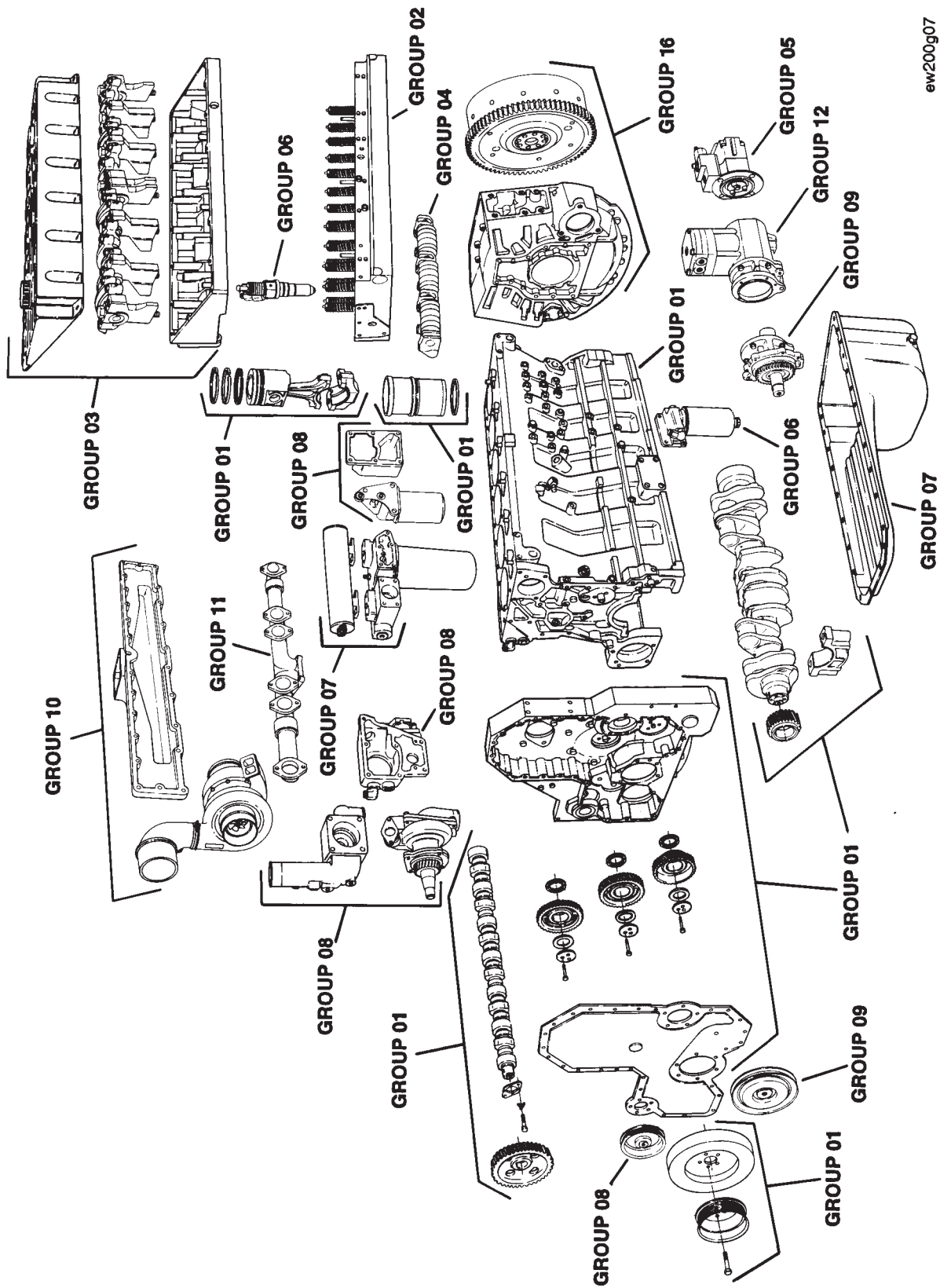

Section i - Introduction

Section Contents

	Page
About the Manual	i-2
Definition Of Terms	i-11
General Cleaning Instructions	i-10
Glass or Plastic Bead Cleaning	i-10
Solvent and Acid Cleaning	i-10
Steam Cleaning.....	i-10
General Repair Instructions	i-9
Welding on a CELECT™ Controlled Vehicle.....	i-9
General Safety Instructions	i-8
Important Safety Notice	i-8
How to Use the Manual	i-2
Illustrations	i-7
Simbolos	i-4
Symbole	i-5
Symboles	i-6
Symbols	i-3

About the Manual

This M11 Shop Manual is intended to aid mechanics in disassembly, inspecting parts for reuse, rebuilding and assembly of components on M11 engines. The manual is divided into sections. Section 0 outlines the disassembly and assembly of the engine while the other sections detail specific components.

How to Use the Manual

This manual is divided in the same group system used for Cummins' filmcard system. Each group is organized in a way that all mechanics, both those who are and are not familiar with the M11 engine models, can reference the manual. Refer to the Table of Contents at the front of the manual to determine the group that details the desired information.

Each group contains the following in sequence:

- Section contents at the beginning of each group to quickly aid in locating the information desired.
- Service tools list with recommended tools needed to rebuild the components.
- General information to aid in rebuilding the component, and an explanation of design change differences.
- Step-by-step rebuild instructions for disassembly, cleaning, inspection and assembly of the component.
- Symbols which represent the action outlined in the instructions. The definitions of the symbols, listed in four languages (English, Spanish, French and German), appear on pages i-3 through i-6.

Topics will be listed alphabetically on the "Section Contents" page. All procedures are described using the "text symbol picture" (TSP) format. In general, each component rebuild will be described through a 3-step sequence of: (1) cleaning and inspection for reuse; (2) rebuild; and (3) replacement. Reference numbers (procedure numbers) are assigned to each process. Reference numbers are constructed with a section number and a two-digit sequenced number.

Both metric and U.S. customary values are used in this manual. The metric value is listed first, followed by the U.S. customary in brackets. An example is 60°C [140°].

Symbols

The following symbols have been used in this manual to help communicate the intent of the instructions. When one of the symbols appears, it conveys the meaning defined below:



WARNING - Serious personal injury or extensive property damage can result if the warning instructions are **not** followed.



CAUTION - Minor personal injury can result, or a part, an assembly, or the engine can be damaged if the caution instructions are **not** followed.



Indicates a **REMOVAL** or **DISASSEMBLY** step.



Indicates an **INSTALLATION** or **ASSEMBLY** step.



INSPECTION is required.



CLEAN the part or assembly.



PERFORM a mechanical or time **MEASUREMENT**.



LUBRICATE the part or assembly.



Indicates that a **WRENCH** or **TOOL SIZE** will be given.



TIGHTEN to a specific torque.



PERFORM an electrical **MEASUREMENT**.



Refer to another location in this manual or another publication for additional information.



The component weighs 23 kg [50 lb] or more. To avoid personal injury, use a hoist or get assistance to lift the component.

Simbolos

Los símbolos siguientes son usados en este manual para clarificar el proceso de las instrucciones. Cuando aparece uno de estos símbolos, su significado se especifica en la parte inferior.



ADVERTENCIA - Serios daños personales o daño a la propiedad puede resultar si las instrucciones de Advertencia **no** se consideran.



PRECAUCION - Daños menores pueden resultar, o de piezas del conjunto o el motor puede averiarse si las instrucciones de Precaución **no** se siguen.



Indica un paso de **REMOCION** o **DESMONTAJE**.



Indica un paso de **INSTALACION** o **MONTAJE**.



Se requiere **INSPECCION**.



LIMPIESE la pieza o el montaje.



EJECUTESE una **MEDICION** mecánica o del tiempo.



LUBRIQUESE la pieza o el montaje.



Indica que se dará una **LLAVE DE TUERCAS** o el **TAMAÑO DE HERRAMIENTA**.



APRIETESE hasta un par torsor específico.



EJECUTESE una **MEDICION** eléctrica.



Para información adicional refiérase a otro emplazamiento de este manual o a otra publicación anterior.



El componente pesa 23 kg [50 lb] o mas. Para evitar dano corporal empleen una cabria u obtengan ayuda para elevar el componente.

Symbole

In diesem Handbuch werden die folgenden Symbole verwendet, die wesentliche Funktionen hervorheben. Die Symbole haben folgende Bedeutung:



WARNUNG - Wird die Warnung **nicht** beachtet, dann besteht erhöhte Unfall- und Beschädigungsgefahr.



VORSICHT - Werden die Vorsichtsmassnahmen **nicht** beachtet, dann besteht Unfall- und Beschädigungsgefahr.



AUSBAU bzw. **ZERLEGEN**.



EINBAU bzw. **ZUSAMMENBAU**.



INSPEKTION erforderlich.



Teil oder Baugruppe **REINIGEN**.



DIMENSION - oder **ZEITMESSUNG**.



Teil oder Baugruppe **ÖLEN**.



WERKZEUGGRÖSSE wird angegeben.



ANZUG auf vorgeschriebenes Drehmoment erforderlich.



Elektrische **MESSUNG DURCHFÜHREN**.



Weitere Informationen an anderer Stelle bzw. in anderen Handbüchern.



Das teil wiegt 23 kg [50 lb] oder mehr. Zur vermeidung von koerperverletzung winde benutzen oder hilfe beim heben des teils in anspruch nehmen.

Symboles

Les symboles suivants sont utilisés dans ce manuel pour aider à communiquer le but des instructions. Quand l'un de ces symboles apparaît, il évoque le sens défini ci-dessous:



AVERTISSEMENT - De graves lésions corporelles ou des dommages matériels considérables peuvent survenir si les instructions données sous les rubriques "Avertissement" **ne sont pas** suivies.



ATTENTION - De petites lésions corporelles peuvent survenir, ou bien une pièce, un ensemble ou le moteur peuvent être endommagés si les instructions données sous les rubriques "Attention" **ne sont pas** suivies.



Indique une opération de **DEPOSE**.



Indique une opération de **MONTAGE**.



L'INSPECTION est nécessaire.



NETTOYER la pièce ou l'ensemble.



EFFECTUER une **MESURE** mécanique ou de temps.



GRAISSER la pièce ou l'ensemble.



Indique qu'une **DIMENSION DE CLE** ou **D'OUTIL** sera donnée.



SERRER à un couple spécifique.



EFFECTUER une **MESURE** électrique.



Se reporter à un autre endroit dans ce manuel ou à une autre publication pour obtenir des informations plus complètes.



Le composant pèse 23 kg [50 lb] ou davantage. Pour éviter toute blessure, employer un appareil de levage ou demander de l'aide pour le soulever.

Illustrations

The illustrations used in the "Repair Sections" of this manual are intended to give an example of a problem, and to show what to look for and where the problem can be found. Some of the illustrations are "generic" and might **not** look exactly like the engine or parts used in your application. The illustrations can contain symbols to indicate an action required, and an acceptable or **not** acceptable condition.

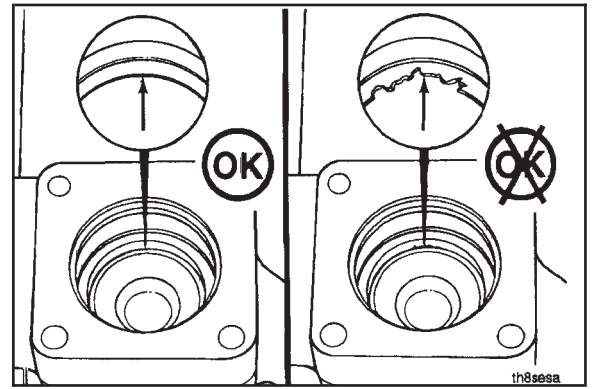

The illustrations are intended to show repair or replacement procedures. The illustration can differ from your application, but the procedure given will be the same.

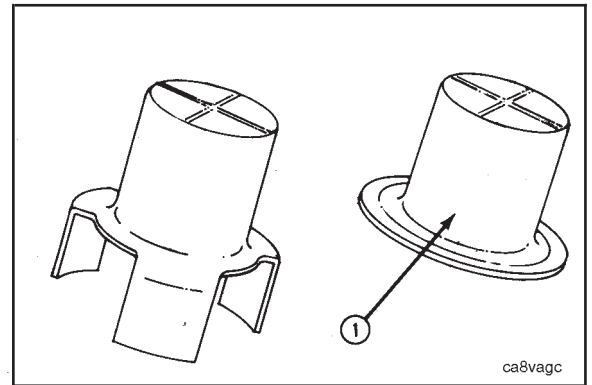

General Safety Instructions

Important Safety Notice



Improper practices or carelessness can cause burns, cuts, mutilation, asphyxiation or other bodily injury or death.

Read and understand all of the safety precautions and warnings before performing any repair. This list contains the general safety precautions that **must** be followed to provide personal safety. Special safety precautions are included in the procedures when they apply.

- Make sure the work area surrounding the product is dry, well lit, ventilated; free from clutter, loose tools, parts, ignition sources and hazardous substances. Be aware of hazardous conditions that can exist.
- **Always** wear protective glasses and protective shoes when working.
- Rotating parts can cause cuts, mutilation or strangulation.
- Do **not** wear loose-fitting or torn clothing. Remove all jewelry when working.
- Disconnect the battery (negative [-] cable first) and discharge any capacitors before beginning any repair work. Disconnect the air starting motor if equipped to prevent accidental engine starting. Put a “Do **Not** Operate” tag in the operator’s compartment or on the controls.
- Use **ONLY** the proper engine barring techniques for manually rotating the engine. Do **not** attempt to rotate the crankshaft by pulling or prying on the fan. This practice can cause serious personal injury, property damage, or damage to the fan blade(s) causing premature fan failure.
- If an engine has been operating and the coolant is hot, allow the engine to cool before you slowly loosen the filler cap and relieve the pressure from the cooling system.
- Do **not** work on anything that is supported **ONLY** by lifting jacks or a hoist. **Always** use blocks or proper stands to support the product before performing any service work.
- Relieve all pressure in the air, oil, and the cooling systems before any lines, fittings, or related items are removed or disconnected. Be alert for possible pressure when disconnecting any device from a system that utilizes pressure. Do **not** check for pressure leaks with your hand. High pressure oil or fuel can cause personal injury.
- To prevent suffocation and frostbite, wear protective clothing and **ONLY** disconnect liquid refrigerant (freon) lines in a well ventilated area. To protect the environment, liquid refrigerant systems **must** be properly emptied and filled using equipment that prevents the release of refrigerant gas (fluorocarbons) into the atmosphere. Federal law requires capture and recycling refrigerant.
- To avoid personal injury, use a hoist or get assistance when lifting components that weigh 23 kg [50 lb] or more. Make sure all lifting devices such as chains, hooks, or slings are in good condition and are of the correct capacity. Make sure hooks are positioned correctly. **Always** use a spreader bar when necessary. The lifting hooks **must not** be side-loaded.
- Corrosion inhibitor contains alkali. Do **not** get the substance in your eyes. Avoid prolonged or repeated contact with skin. Do **not** swallow internally. In case of contact, immediately wash skin with soap and water. In case of contact, immediately flood eyes with large amounts of water for a minimum of 15 minutes. **IMMEDIATELY CALL A PHYSICIAN. KEEP OUT OF REACH OF CHILDREN.**
- Naptha and Methyl Ethyl Ketone (MEK) are flammable materials and **must** be used with caution. Follow the manufacturer’s instructions to provide complete safety when using these materials. **KEEP OUT OF REACH OF CHILDREN.**
- To avoid burns, be alert for hot parts on products that have just been turned OFF, and hot fluids in lines, tubes, and compartments.
- **Always** use tools that are in good condition. Make sure you understand how to use them before performing any service work. Use **ONLY** genuine Cummins or Cummins Recon® replacement parts.
- **Always** use the same fastener part number (or equivalent) when replacing fasteners. Do **not** use a fastener of lesser quality if replacements are necessary.
- Do **not** perform any repair when fatigued or after consuming alcohol or drugs that can impair your functioning.
- Some state and federal agencies in the United States of America have determined that used engine oil can be carcinogenic and can cause reproductive toxicity. Avoid inhalation of vapors, ingestion, and prolonged contact with used engine oil.

General Repair Instructions

This engine incorporates the latest diesel technology at the time it was manufactured; yet, it is designed to be repaired using normal repair practices performed to quality standards.

- **Cummins Engine Company, Inc. does not recommend or authorize any modifications or repairs to engines or components except for those detailed in Cummins Service Information. In particular, unauthorized repair to safety-related components can cause personal injury or death. Below is a partial listing of components classified as safety-related:**

- **Air Compressor**
- **Air Controls**
- **Air Shutoff Assemblies**
- **Balance Weights**
- **Cooling Fan**
- **Fan Hub Assembly**
- **Fan Mounting Bracket(s)**
- **Fan Mounting Capscrews**
- **Fan Hub Spindle**
- **Flywheel**
- **Flywheel Crankshaft Adapter**
- **Flywheel Mounting Capscrews**
- **Fuel Shutoff Assemblies**
- **Fuel Supply Tubes**
- **Lifting Brackets**
- **Throttle Controls**
- **Turbocharger Compressor Casing**
- **Turbocharger Oil Drain Line(s)**
- **Turbocharger Oil Supply Line(s)**
- **Turbocharger Turbine Casing**
- **Vibration Damper Mounting Capscrews**

- **Follow All Safety Instructions Noted in the Procedures.**
 - Follow the manufacturer's recommendations for cleaning solvents and other substances used during the repair of the engine. Some solvents and used engine oil have been identified by government agencies as toxic or carcinogenic. Avoid excessive breathing, injection and contact with such substances. **Always** use good safety practices with tools and equipment.
- **Provide A Clean Environment and Follow the Cleaning Instructions Specified in the Procedures**
 - The engine and its components **must** be kept clean during any repair. Contamination of the engine or components will cause premature wear.
- **Perform the Inspections Specified in the Procedures.**
- **Replace all Components or Assemblies Which are Damaged or Worn Beyond the Specifications**
- **Use Genuine Cummins New or ReCon® Service Parts and Assemblies**
 - The assembly instructions have been written to use again as many components and assemblies as possible. When it is necessary to replace a component or assembly, the procedure is based on the use of new Cummins or Cummins ReCon® components. All of the repair services described in this manual are available from all Cummins Distributors and most Dealer locations.
- **Follow The Specified Disassembly and Assembly Procedures to Avoid Damage to the Components.**

Complete rebuild instructions are available in the shop manual which can be ordered or purchased from a Cummins Authorized Repair Location. Refer to Section L, Literature, for ordering instructions.

Welding on a CELECT™ Controlled Vehicle



Caution: When welding on a CELECT™ controlled vehicle, to protect the ECM computer circuits, the procedure below MUST be followed:

1. Remove all three connectors going to the ECM.
2. Disconnect the negative (-) and positive (+) battery cables from the battery.
3. Do **NOT** connect the welder ground cable to any part of the CELECT™ control system.

General Cleaning Instructions

Solvent and Acid Cleaning

Several solvent and acid-type cleaners can be used to clean the engine parts. **Cummins Engine Company, Inc. does not recommend any specific cleaners. Always** follow the cleaner manufacturer's instructions.

Experience has shown that the best results can be obtained using a cleaner that can be heated to 90 to 95 degrees Celsius [180 to 200 degrees Fahrenheit]. A cleaning tank that provides a constant mixing and filtering of the cleaning solution will give the best results.



Remove all the gasket material, o-rings, and the deposits of sludge, carbon, etc., with a wire brush or scraper before putting the parts in a cleaning tank. Be careful **not** to damage any gasket surfaces. When possible, steam clean the parts before putting them in the cleaning tank.



Warning: Acid is extremely dangerous, and can damage the machinery. Always provide a tank of strong soda water as a neutralizing agent.

Rinse all of the parts in hot water after cleaning. Dry completely with compressed air. Blow the rinse water from all of the capscrew holes and the oil drillings.

If the parts are **not** to be used immediately after cleaning, dip them in a suitable rustproofing compound. The rustproofing compound **must** be removed from the parts before installation on the engine.

Steam Cleaning

Steam cleaning can be used to remove all types of dirt that can contaminate the cleaning tank. It is a good way to clean the oil drillings.



Warning: Wear protective clothing to prevent personal injury from the high pressure and extreme heat.

Do **not** steam clean the following parts:



1. Electrical Components
2. Wiring
3. Injectors
4. Fuel Pump
5. Belts and Hoses
6. Bearings

Glass or Plastic Bead Cleaning

Glass or plastic bead cleaning can be used on many engine components to remove carbon deposits. The cleaning process is controlled by the size of the glass or plastic beads, the operating pressure, and the cleaning time.



Caution: Do not use glass or plastic bead cleaning on aluminum piston skirts. Do not use glass bead cleaning on aluminum ring grooves. Small particles of glass or plastic will embed in the aluminum and result in premature wear. Valves, turbocharger shafts, etc., can also be damaged. Follow the cleaning directions listed in the procedures.



NOTE: Plastic bead blasting media, Part No. 3822735, can be used to clean aluminum ring grooves. Do **not** use any bead blasting media on pin bores or aluminum skirts.

Follow the equipment manufacturer's cleaning instructions. The following guidelines can be used to adapt to manufacturer's instructions:

1. Bead size: - Use U.S. size No. 16-20 for piston cleaning with plastic bead media, Part No. 3822735.
- Use U.S. size No. 70 for piston domes with glass media.
- Use U.S. size No. 60 for general purpose cleaning with glass media.
2. Operating Pressure: - Glass: Use 620 kPa [90 psi] for general purpose cleaning.
- Plastic: Use 270 kPa [40 psi] for piston cleaning.
3. Steam clean or wash the parts with solvent to remove all of the foreign material and glass or plastic beads after cleaning. Rinse with hot water. Dry with compressed air.
4. Do **not** contaminate the wash tanks with glass or plastic beads.

Definition Of Terms

A.C.:	Alternating Current
ACT Harness:	The wiring harness used to connect the actuators to the ECM
AFC:	Air Fuel Control; a device in the fuel pump that limits the fuel delivery until there is sufficient intake manifold pressure to allow for complete combustion.
Alligator Clip:	An electrical test clip attached to the end of a wire
API:	American Petroleum Institute
ASA:	Air Signal Attenuator
ASTM:	American Society of Testing and Materials
ATDC:	After Top Dead Center; refers to the position of the piston or the crankshaft rod journal. The piston is moving downward on the power stroke or intake stroke.
BDC:	Bottom Dead Center; refers to the position of the piston or the crankshaft rod journal. The piston is at its lowest position in the cylinder.
BTDC:	Before Top Dead Center; refers to the position of the piston or the crankshaft rod journal. The piston is moving upward on the power stroke or exhaust stroke.
C:	Celsius
CAC:	Charge Air Cooler
CARB:	California Air Resources Board
CELECT™:	<p>A fuel control system that electronically controls the fuel injection to improve fuel economy and to reduce the exhaust emissions. The system does this by controlling the torque and horsepower curve, AFC (smoke) function, engine high speed, engine low idle speed and the road speed.</p> <p>The CELECT™ system also can control fan clutch operation, engine brake enabling and turbocharger wastegating.</p> <p>Additional electronic features include cruise control, PTO, gear down protection, progressive shifting, automotive or VS governor and idle shutoff.</p>
C.I.D.:	Cubic Inch Displacement
Circumferential Direction:	In the direction of a circle in respect to the centerline of a round part or a bore.
Cm:	Centimeter
Compulink™:	A Cummins service tool used for electronic system analysis and to reprogram the system
Concentricity:	A measurement of the difference between the centers of either two or more parts, or the bores in one part.
CPL:	Control Parts List; this listing identifies the specific parts that must be installed on the engine to meet agency certification.
cSt:	Centistokes
Cummins Sealant:	<p>This is a one part Room Temperature Vulcanizing (RTV) silicone rubber, adhesive and sealant material having high heat and oil resistance, and low compression set.</p> <p>Some of the equivalent products are Marston Lubricants, Hylosil, Dow Corning, Silastic 732, Loctite Superflex, General Electric 1473, and General Electric 1470.</p>
D.C.:	Direct Current

Deutsch Connector:	An electrical connector
Dye Penetrant Method:	A method used to check for cracks in a part by using a dye penetrant and a developer. Use Part No. 3375432 Crack Detection Kit, or equivalent.
End Clearance:	The clearance in an assembly determined by pushing the shaft in an axial direction one way , and then pushing the shaft the other way .
ECM:	Electronic Control Module.
E.C.S.:	Emission Control System
EFC:	Electric Fuel Control
EPA:	Environmental Protection Agency
EPS:	Engine Position Sensor
E.S.N.:	Engine Serial Number
ESS:	Engine Speed Sensor
F:	Fahrenheit
ft-lb:	Foot Pound
GPM:	Gallons Per Minute
GVW:	Gross Vehicle Weight
Hammer:	A hand tool consisting of a hard steel head on a handle.
Hg:	Mercury
HP:	Horsepower
H ₂ O:	Water
ID:	Inside Diameter
in-lb:	Inch Pound
kg:	Kilograms
km:	Kilometers
km/l:	Kilometers per Liter
kPa:	Kilopascal
l:	Liter
Loctite 290:	A single component, anaerobic, polyester resin, liquid sealant compound that hardens between closely fitted metal surfaces producing a tough, hard bond with good characteristics. An equivalent product is Perma-Lok HL 126.
Loctite 609:	A single component anaerobic, liquid adhesive that meets or exceeds the requirements of MIL-R-46082A (MR) TYPE 1. Some of the equivalent products are Loctite 601 and Permabond HL 138.
Lubriplate 105:	A mineral oil base grease with calcium soap (2 percent to 6 percent), and zinc oxide (2 percent to 4 percent) additives.
m:	Meter
Magnetic Particle Inspection:	A method of checking for cracks in either steel or iron parts. This method requires a Magnaflux machine, or an equivalent machine that imparts a magnetic field on the part being checked.
Mallet:	A hand tool consisting of a soft head; either wood, plastic, lead, brass, or rawhide on a handle.
MAX:	Maximum allowed
MIN:	Minimum allowed
Mini-Gen:	Speed Sensor

mm:	Millimeter
MPa:	Megapascal
MPH:	Miles Per Hour
MPQ:	Miles Per Quart
N•m:	Newton-meter
No.:	Number
OD:	Outside Diameter
OEM:	Original Equipment Manufacturer
OEM Harness:	The wiring harness used to connect the ECM to the vehicle
OS:	Oversize
PCU:	PACER Control Unit
ppm:	Parts Per Million
Protrusion:	The difference in the height between two parts in the assembled state.
psi:	Pounds Per Square Inch
PTO:	Power Takeoff
REPTO:	Rear Engine Power Takeoff
RPM:	Revolutions Per Minute
S.A.E.:	Society of Automotive Engineers
SCA:	Supplemental Coolant Additive
SEN Harness:	The wiring harness used to connect the engine system sensors to the ECM
STD:	Standard
TC:	Torque Converter; used when referring to the torque converter cooler.
TDC:	Top Dead Center; refers to the position of the piston or the crankshaft rod journal. The piston is at its highest position in the cylinder. The rod journal is pointing straight up toward the piston.
TIR:	Total Indicator Reading; used when measuring the concentricity or the run out. The TIR refers to the total movement of the needle on a dial indicator, from the most negative reading to the most positive reading.
VOM:	Volt Ohm Meter
VS:	Variable Speed
VSS:	Vehicle Speed Sensor
Water Pump Grease:	<p>A premium high temperature grease that will lubricate antifriction bearings continually from minus 40 C [minus 40 F] to plus 150 C [plus 350 F].</p> <p>Some of the greases meeting this requirement are Aeroshell No. 5, Chevron SRI, Amoco Rykon Premium No. 2, Texaco Premium RB, and Shell Dolium R.</p> <p>Caution: Aeroshell No. 5 is not compatible with the other greases and must not be mixed. Cummins Engine Co., Inc., uses Aeroshell No. 5 on new engines and components.</p>

Section E - Engine Identification

Section Contents

	Page
Engine Diagrams	E-6
Engine Identification	E-2
Electronic Control Module (ECM) Dataplate	E-2
Engine Dataplate	E-2
Engine Specifications	E-3
Air Intake System	E-4
Batteries (Specific Gravity)	E-5
Cooling System	E-4
Electrical System	E-5
Exhaust System	E-4
Fuel System	E-5
General Engine Data	E-3
Lubricating Oil System	E-4

Engine Identification

The model name provides the following data:

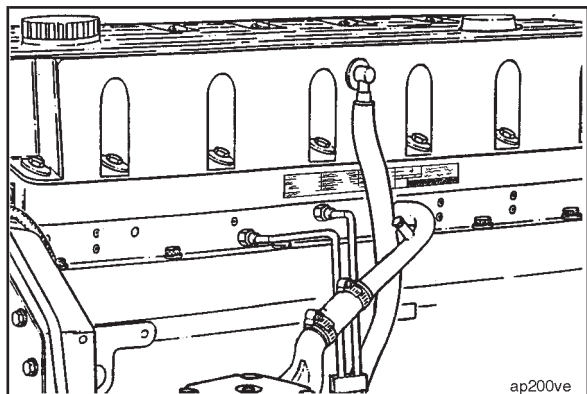
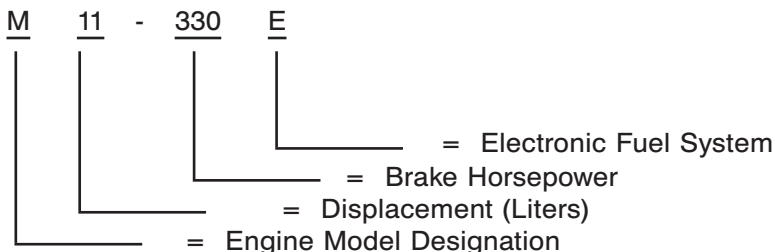

Engine Dataplate

The engine dataplate is located on the fuel pump side of the rocker housing.

The engine dataplate provides model identification as well as other important information about the engine.

Have the following engine data available when communicating with a Cummins Authorized Repair Location. The information on the dataplate is **mandatory** when sourcing service parts.

1. Engine Serial Number (E.S.N.)
2. Control Parts List (CPL)
3. Model
4. Horsepower and RPM Rating

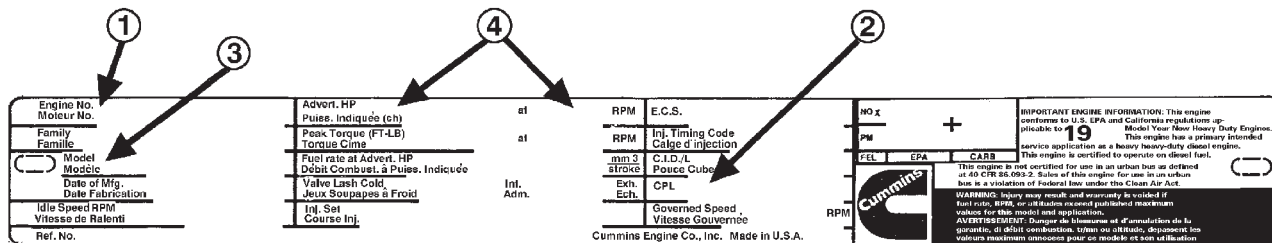

ap200va

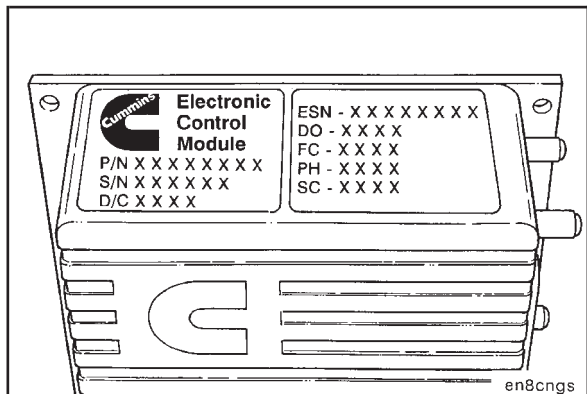

Electronic Control Module (ECM) Dataplate

On SELECT™ engines, there are two dataplates on the top of the electronic control module (ECM).

The dataplate on the left contains the part number (P/N), serial number (S/N) and the date code (D/C) of the ECM.

The dataplate on the right contains the engine serial number, fuel code and engine calibration information.