

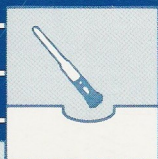

Shop Manual

L10 Series Engines

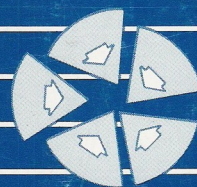

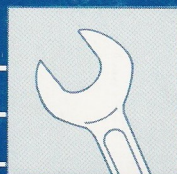
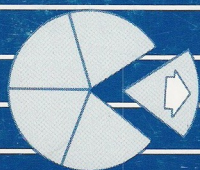

Shop Manual L10 Series Engines Internal Damper Models

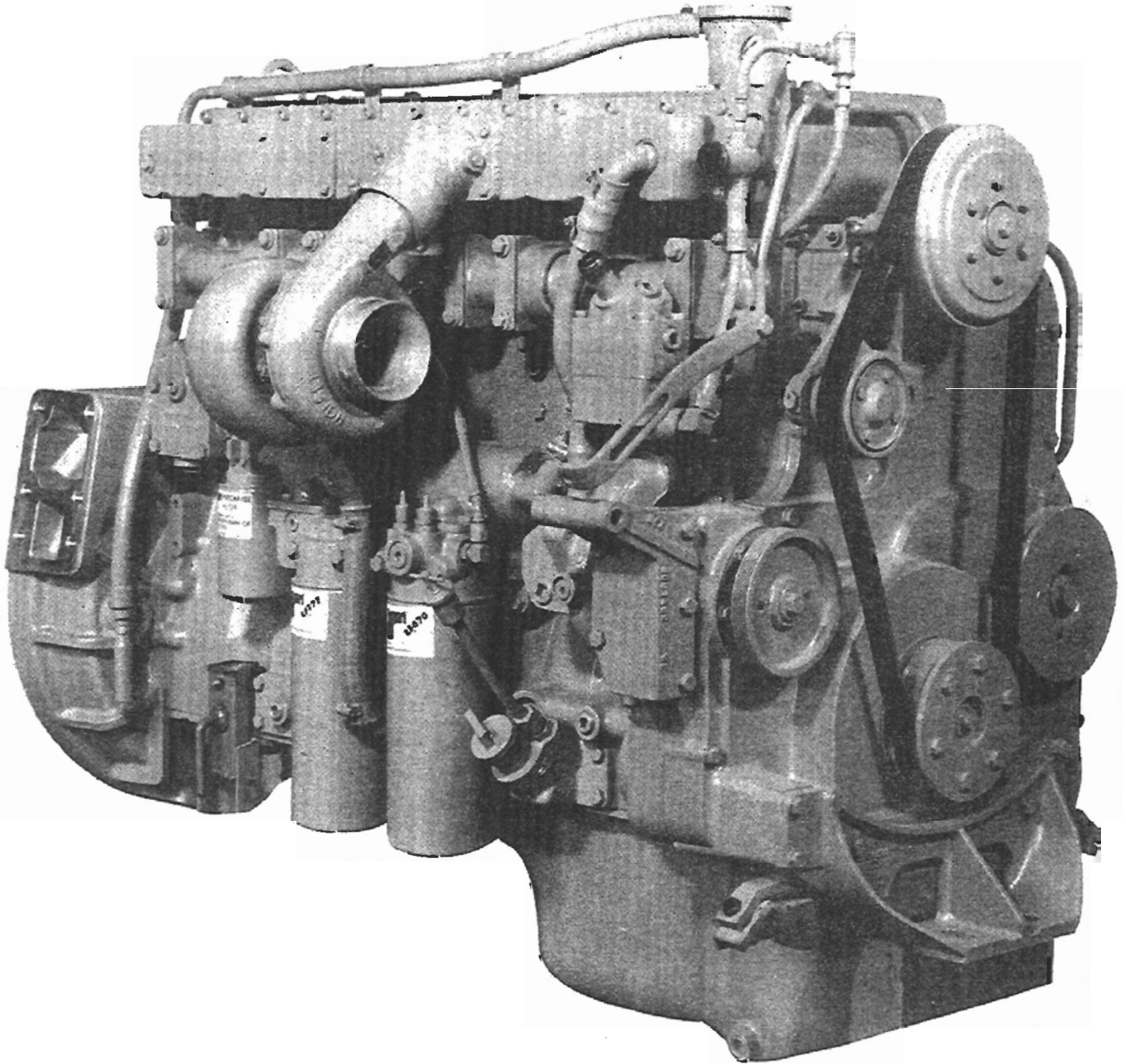

Copyright © 1994
Cummins Engine Company, Inc.
All Rights Reserved

Bulletin No. 3379347-07
Printed 7/94

Foreword

This manual contains complete rebuild specifications and information for the L10 engine and all associated components manufactured by Cummins Engine Company, Inc. A listing of accessory and component suppliers' addresses and telephone numbers is located in Section C-1. Suppliers can be contacted directly for any information **not** covered in this manual.

The repair procedures in this manual are based on the engine being installed on an approved engine stand. Some rebuild procedures require the use of special service tools. Make sure the correct tools are used as described in the procedures.

When a specific brand name, number, or special tool is referenced in this manual, an equivalent product can be used in place of the recommended item.

A series of specific L10 service manuals (Troubleshooting and Repair, Specifications, Alternative Repair, etc.) are available and can be ordered by filling out and mailing the Literature Order Form located in the Service Literature Section L-1.

Reporting of errors, omissions, and recommendations for improving this publication by the user is encouraged. Please use the postage paid, self-addressed Literature Survey Form in the back of this manual for communicating your comments.

The specifications and rebuild information in this manual is based on the information in effect at the time of printing. Cummins Engine Company, Inc. reserves the right to make any changes at any time without obligation. If differences are found between your engine and the information in this manual, contact a Cummins Authorized Repair Location, a Cummins Division Office, or the factory.

The latest technology and the highest quality components are used to manufacture Cummins engines. When replacement parts are needed, we recommend using only genuine Cummins or ReCon® exchange parts. These parts can be identified by the following trademarks:



TABLE OF CONTENTS

	Page
Introduction.....	i-1
Group 0 - Engine Disassembly and Assembly.....	0-1
Group 1 - Cylinder Block.....	1-1
Group 2 - Cylinder Head.....	2-1
Group 3 - Rocker Levers.....	3-1
Group 4 - Cam Followers.....	4-1
Group 5 - Fuel System.....	5-1
Group 6 - Injectors and Fuel Lines.....	6-1
Group 7 - Lubricating Oil System.....	7-1
Group 8 - Cooling System.....	8-1
Group 9 - Drive Units.....	9-1
Group 10 - Air Intake System.....	10-1
Group 11 - Exhaust System.....	11-1
Group 12 - Air Equipment.....	12-1
Group 13 - Electrical Equipment.....	13-1
Group 14 - Engine Testing.....	14-1
Group 15 - Instruments and Controls.....	15-1
Group 16 - Mounting Adaptations.....	16-1
Group 18 - Specifications.....	18-1
Group 20 - Vehicle Braking.....	20-1
Component Manufacturers: Names and Addresses.....	C-1
Service Literature.....	L-1
Index.....	X-1
Literature Survey Form.....	back

Introduction

Contents

Manual Organization	i-2
Safety, General Instructions	i-3
Symbols Used in This Manual.....	i-5
- English	
- Spanish	
- French	
- German	
Illustrations.....	i-9
Glossary of Terms.....	i-10
Engine Identification	i-12
Engine Diagrams	i-13
Cleaning, General Instructions	
Glass and Plastic Beads.....	i-15
Solvent and Acid	i-15
Steam.....	i-15
Repair, General Instructions	i-16

Manual Organization

All references to engine components in this manual are divided into 22 specific groups. The organization is consistent with the service bulletins, service parts topics, and the parts catalogs for your convenience in updating the shop manual.

Table of Contents

The Table of Contents in the front of the manual contains a quick page reference for each group number.

Group Contents

Each group contains the following information:

- A Contents page at the beginning of each group to quickly aid in locating the information desired.
- A Service Tools list with recommended tools needed to rebuild the components.
- General information to aid in rebuilding the component and an explanation of design change differences.
- Step-by-step rebuild instructions for disassembly, cleaning, inspection, and assembly of the component.
- Symbols which represent the action outlined in the instructions. The definitions of the symbols, listed in four languages (English, Spanish, French, and German), appear on pages i-5 through i-8.

Index

An alphabetical Index is in the back of the manual to aid in locating specific information.

Metric Information

Both metric and U.S. customary values are used in this manual. The metric value is listed first, followed by the U.S. customary in brackets. An example is 60°C [140°F].

General Safety Instructions

Important Safety Notice

Read and understand all safety precautions and warnings before performing repairs.

 This symbol appears in the manual when a potential safety hazard exists that can cause personal injury or death. These hazards are not always apparent to a trained mechanic.

It is not possible for Cummins Engine Co., Inc. to anticipate every possible circumstance that can involve a potential hazard.

 **Warning:** Cummins Engine Company, Inc. does not recommend or authorize any modifications or repairs to engines or components except for those detailed in **CUMMINS SERVICE INFORMATION**.

In particular, unauthorized repair to safety-related components can cause personal injury. Components classified as safety-related include the following:

- Air Compressor
- Air Controls
- Air Shutoff Assemblies
- Balance Weights
- Cooling Fan
- Fan Hub Assembly
- Fan Mounting Bracket(s)
- Fan Mounting Capscrews
- Fan Hub Spindle
- Flywheel
- Flywheel Crankshaft Adapter
- Flywheel Mounting Capscrews
- Fuel Shutoff Assemblies
- Fuel Supply Tubes
- Lifting Brackets
- Throttle Controls
- Turbocharger Compressor Casing
- Turbocharger Oil Drain Line(s)
- Turbocharger Oil Supply Line(s)
- Turbocharger Turbine Casing
- Vibration Damper Mounting Capscrews

Read and understand all of the safety precautions and warnings before performing any repair. This list contains the general safety precautions that **must** be followed to provide personal safety. Special safety precautions are included in the procedures when they apply.

 Be sure the work area surrounding the product is safe. Be aware of hazardous conditions that can exist.

 Always wear protective glasses and protective shoes when working.

 Do not wear loose-fitting or torn clothing. Remove all jewelry such as rings, watches, etc., when working.

 Disconnect the battery and discharge any capacitors before beginning any repair work. Disconnect the air starter if equipped to prevent accidental engine starting. Put a "Do Not Operate" tag in the operator's compartment or on the controls.

General Safety Instructions

Important Safety Notice



Use **ONLY** the proper engine barring techniques for manually rotating the engine. Do not attempt to rotate the engine by pulling or prying on the fan. This practice can cause serious personal injury, property damage, or damage to the fan blade(s) causing premature fan failure.



If an engine has been operating and the coolant is hot, allow the engine to cool before you slowly loosen the filler cap and relieve the pressure from the cooling system.



Do not work on anything that is supported **ONLY** by lift jacks or a hoist. Always use blocks or proper stands to support the product before performing any service work.



Relieve all pressure in the air, oil, and the cooling systems before any lines, fittings, or related items are removed or disconnected. Be alert for possible pressure when disconnecting any device from a system that utilizes pressure. Do not check for pressure leaks with your hand. High pressure oil or fuel can cause personal injury.



To prevent suffocation and frostbite, wear protective clothing and **ONLY** disconnect liquid refrigerant (freon) lines in a well ventilated area.



To avoid personal injury, use a hoist or get assistance when lifting components that weigh 23 kg [50 lbs] or more. Be sure all chains, hooks, slings, etc., are in good condition and are of the correct capacity. Be sure hooks are positioned correctly. Always use a spreader bar when necessary. The lifting hooks must not be side-loaded.



Corrosion inhibitor contains alkali. Do not get the substance in your eyes. Avoid prolonged or repeated contact with skin. Do not swallow internally. In case of contact, immediately wash skin with soap and water. In case of contact, immediately flood eyes with large amounts of water for a minimum of 15 minutes. **IMMEDIATELY CALL A PHYSICIAN. KEEP OUT OF REACH OF CHILDREN .**



Naptha and Methyl Ethyl Ketone (MEK) are flammable materials and must be used with caution. Follow the manufacturer's instructions to provide complete safety when using these materials. **KEEP OUT OF REACH OF CHILDREN.**



To avoid burns, be alert for hot parts on products that have just been turned **OFF**, and hot fluids in lines, tubes, and compartments.



Always use tools that are in good condition. Be sure you understand how to use them before performing any service work. Use **ONLY** genuine Cummins or Cummins Recon® replacement parts.



Always use the same fastener part number (or equivalent) when replacing fasteners. Do not use a fastener of less quality if replacements are necessary.

Symbols Used in this Manual

The following group of symbols have been used in this manual to help communicate the intent of the instructions. When one of the symbols appears, it conveys the meaning defined below.



WARNING - Serious personal injury or extensive property damage can result if the warning instructions are not followed.



CAUTION - Minor personal injury can result or a part, an assembly or the engine can be damaged if the caution instructions are not followed.



Indicates a **REMOVAL** or **DISASSEMBLY** step.



Indicates an **INSTALLATION** or **ASSEMBLY** step.



INSPECTION is required.



CLEAN the part or assembly.



PERFORM a mechanical or time **MEASUREMENT**.



LUBRICATE the part or assembly.



Indicates that a **WRENCH** or **TOOL SIZE** will be given.



TIGHTEN to a specific torque.



PERFORM an electrical **MEASUREMENT**.



Refer to another location in this manual or another publication for additional information.



The component weighs 23 kg [50 lb] or more. To avoid personal injury, use a hoist or get assistance to lift the component.

Simbolos Usados En Este Manual

Los símbolos siguientes son usados en este manual para clarificar el proceso de las instrucciones. Cuando aparece uno de estos símbolos, su significado se especifica en la parte inferior.



ADVERTENCIA - Serios daños personales o daño a la propiedad puede resultar si las instrucciones de Advertencia **no** se consideran.



PRECAUCION - Daños menores pueden resultar, o de piezas del conjunto o el motor puede averiarse si las instrucciones de Precaución **no** se siguen.



Indica un paso de **REMOCION** o **DESMONTAJE**.



Indica un paso de **INSTALACION** o **MONTAJE**.



Se requiere **INSPECCION**.



LIMPIESE la pieza o el montaje.



EJECUTESE una **MEDICION** mecánica o del tiempo.



LUBRIQUESE la pieza o el montaje.



Indica que se dará una **LLAVE DE TUERCAS** o el **TAMAÑO DE HERRAMIENTA**.



APRIETESE hasta un par torsor específico.



EJECUTESE una **MEDICION** eléctrica.



Para información adicional refiérase a otro emplazamiento de este manual o a otra publicación anterior.



El componente pesa 23 kgs [50 lb] o mas. para evitar dano corporal empleen una cabria u obtengan ayuda para elevar el componente.

Symboles Utilisés Dans Ce Manuel

Les symboles suivants sont utilisés dans ce manuel pour aider à communiquer le but des instructions. Quand l'un de ces symboles apparaît, il évoque le sens défini ci-dessous:



AVERTISSEMENT - De graves lésions corporelles ou des dommages matériels considérables peuvent survenir si les instructions données sous les rubriques "Avertissement" ne sont pas suivies.



ATTENTION - De petites lésions corporelles peuvent survenir, ou bien une pièce, un ensemble ou le moteur peuvent être endommagés si les instructions données sous les rubriques "Attention" ne sont pas suivies.



Indique une opération de **DEPOSE**.



Indique une opération de **MONTAGE**.



L'INSPECTION est nécessaire.



NETTOYER la pièce ou l'ensemble.



EFFECTUER une **MESURE** mécanique ou de temps.



GRAISSER la pièce ou l'ensemble.



Indique qu'une **DIMENSION DE CLE** ou **D'OUTIL** sera donnée.



SERRER à un couple spécifique.



EFFECTUER une **MESURE** électrique.



Se reporter à un autre endroit dans ce manuel ou à une autre publication pour obtenir des informations plus complètes.



Le composant pèse 23 kg [50 lb] ou davantage. Pour éviter toute blessure, employer un appareil de levage ou demander de l'aide pour le soulever.

Symbole

In diesem Handbuch werden die folgenden Symbole verwendet, die wesentliche Funktionen hervorheben. Die Symbole haben folgende Bedeutung:



WARNUNG - Wird die Warnung nicht beachtet, dann besteht erhöhte Unfall- und Beschädigungsgefahr.



VORSICHT - Werden die Vorsichtsmassnahmen nicht beachtet, dann besteht Unfall- und Beschädigungsgefahr.



AUSBAU bzw. **ZERLEGEN**.



EINBAU bzw. **ZUSAMMENBAU**.



INSPEKTION erforderlich.



Teil oder Baugruppe **REINIGEN**.



DIMENSION - oder **ZEITMESSUNG**.



Teil oder Baugruppe **ÖLEN**.



WERKZEUGGRÖSSE wird angegeben.



ANZUG auf vorgeschriebenes Drehmoment erforderlich.



Elektrische **MESSUNG DURCHFÜHREN**.



Weitere Informationen an anderer Stelle bzw. in anderen Handbüchern.



Das teil wiegt 23 kg [50 lb] oder mehr. Zur Vermeidung von Körperverletzung Winde benutzen oder Hilfe beim Heben des Teils in Anspruch nehmen.

Illustrations

The illustrations used in this manual are intended to give an example of how to perform the action or the repair being described. Many of the illustrations are common and will not look exactly like the engine or the parts used in your application. Most of the illustrations contain symbols to indicate an action required or to indicate an acceptable (OK) or unacceptable (not OK) condition.

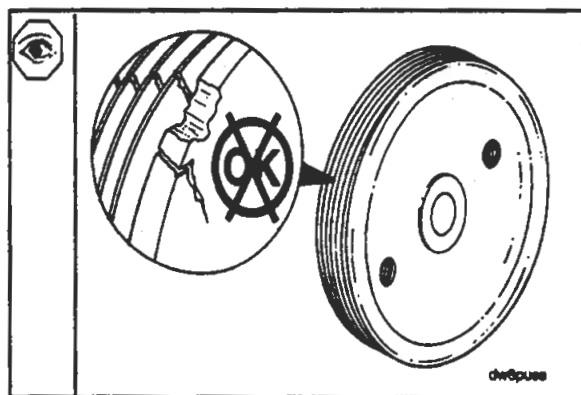
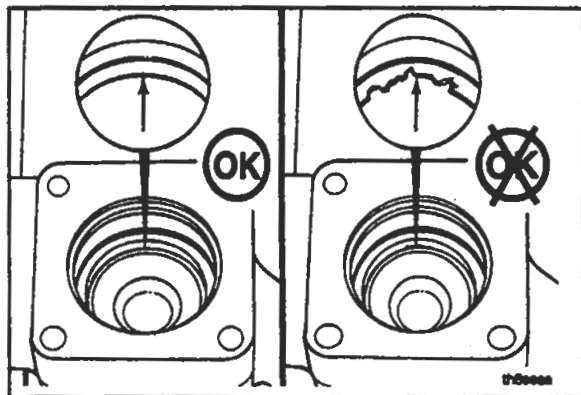

Glossary Of Terms

A.C.:	Alternating Current
AFC:	Air Fuel Control; a device in the fuel pump that limits the fuel delivery until there is sufficient intake manifold pressure to allow for complete combustion.
ATDC:	After Top Dead Center; refers to the position of the piston or the crankshaft rod journal. The piston is moving downward on the power stroke or intake stroke.
BDC:	Bottom Dead Center; refers to the position of the piston or the crankshaft rod journal. The piston is at its lowest position in the cylinder.
BTDC:	Before Top Dead Center; refers to the position of the piston or the crankshaft rod journal. The piston is moving upward on the power stroke or exhaust stroke.
Circumferential Direction:	In the direction of a circle in respect to the centerline of a round part or a bore.
Concentricity:	A measurement of the difference between the centers of either two or more parts, or the bores in one part.
CPL:	Control Parts List; this listing identifies the specific parts that must be installed on the engine to meet agency certification.
Cummins Sealant:	<p>This is a one part Room Temperature Vulcanizing (RTV) silicone rubber, adhesive and sealant material having high heat and oil resistance, and low compression set.</p> <p>Some of the equivalent products are Marston Lubricants, Hylosil, Dow Corning, Silastic 732, Loctite Superflex, General Electric 1473, and General Electric 1470.</p>
D.C.:	Direct Current
Dye Penetrant Method:	A method used to check for cracks in a part by using a dye penetrant and a developer. Use Part No. 3375432 Crack Detection Kit, or equivalent.
End Clearance:	The clearance in an assembly determined by pushing the shaft in an axial direction one way , and then pushing the shaft the other way .
E.S.N.:	Engine Serial Number
Hammer:	A hand tool consisting of a hard steel head on a handle.
ID:	Inside Diameter
Loctite 290:	A single component, anaerobic, polyester resin, liquid sealant compound that hardens between closely fitted metal surfaces producing a tough, hard bond with good characteristics. An equivalent product is Perma-Lok HL 126.

Loctite 609:	A single component anaerobic, liquid adhesive that meets or exceeds the requirements of MIL-R-46082A (MR) TYPE 1. Some of the equivalent products are Loctite 601 and Permabond HL 138.
Lubriplate 105:	A mineral oil base grease with calcium soap (2 percent to 6 percent), and zinc oxide (2 percent to 4 percent) additives.
Magnetic Particle Inspection:	A method of checking for cracks in either steel or iron parts. This method requires a Magnaflux machine, or an equivalent machine that imparts a magnetic field on the part being checked.
Mallet:	A hand tool consisting of a soft head; either wood, plastic, lead, brass, or rawhide on a handle.
MAX:	Maximum allowed
MIN:	Minimum allowed
No.:	Number
O.D.:	Outside Diameter
OS:	Oversize
Protrusion:	The difference in the height between two parts in the assembled state.
STD:	Standard
TC:	Torque Converter; used when referring to the torque converter cooler.
TDC:	Top Dead Center; refers to the position of the piston or the crankshaft rod journal. The piston is at its highest position in the cylinder. The rod journal is pointing straight up toward the piston.
TIR:	Total Indicator Reading; used when measuring the concentricity or the run out. The TIR refers to the total movement of the needle on a dial indicator, from the most negative reading to the most positive reading.
Water Pump Grease:	A premium high temperature grease that will lubricate antifriction bearings continually from minus 40 C [minus 40 F] to plus 150 C [plus 350 F]. Some of the greases meeting this requirement are Aeroshell No. 5, Chevron SRI, Amoco Rykon Premium No. 2, Texaco Premium RB, and Shell Dolium R. Aeroshell No. 5 is not compatible with the other greases and must not be mixed. Cummins Engine Co., Inc., uses Aeroshell No. 5 on new engines and components.

Engine Diagrams

The following drawings contain information about engine components, filter locations, drain points and access locations for instrumentation and engine controls:

The information and configuration of components shown in these drawings are of a general nature. Some component locations will vary depending on applications and installations.

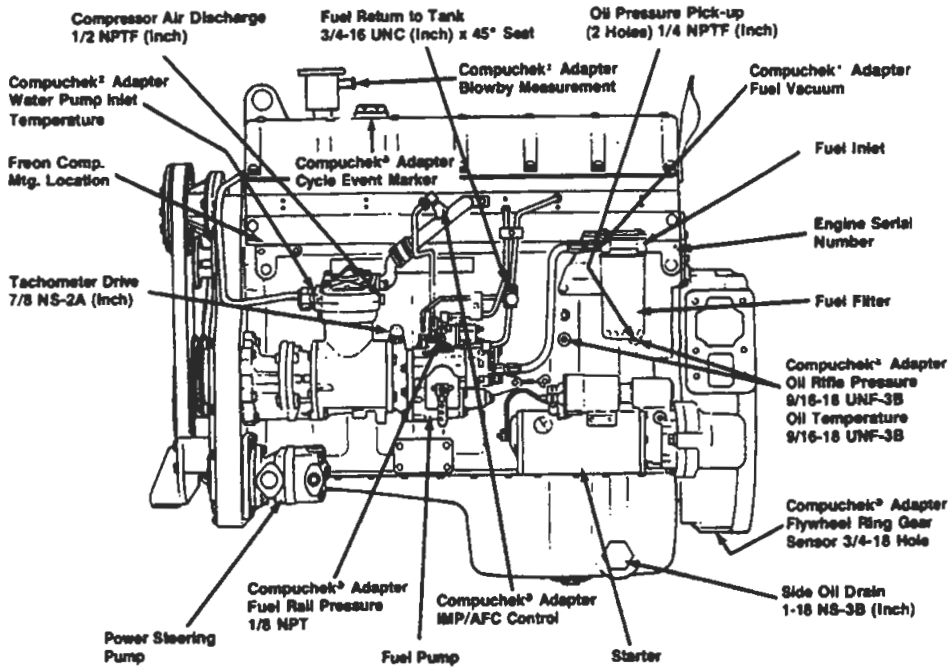

CONVENTIONAL AFTERCOOLING

ew200gx

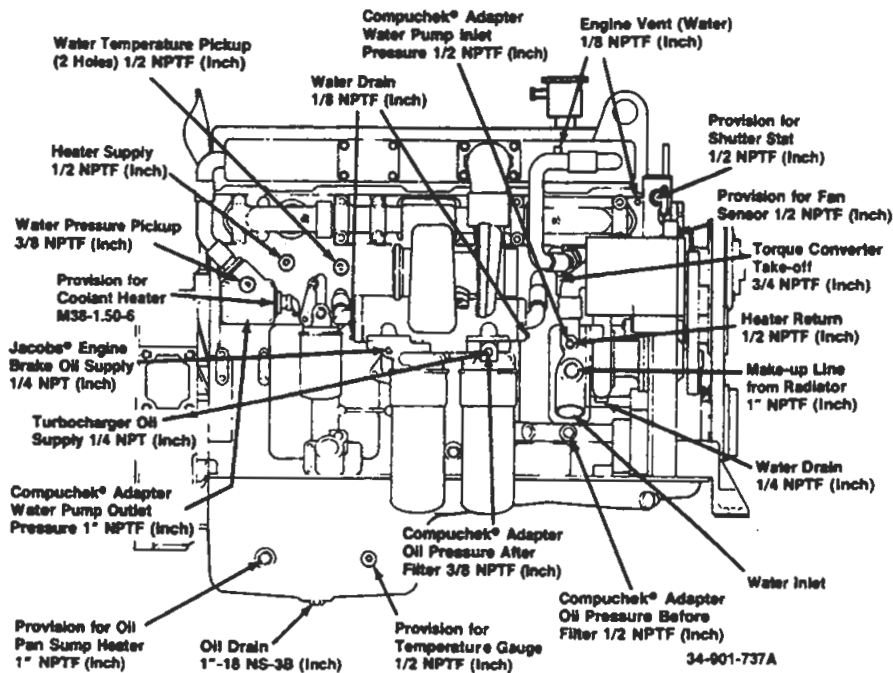

CONVENTIONAL AFTERCOOLING

ew200gy

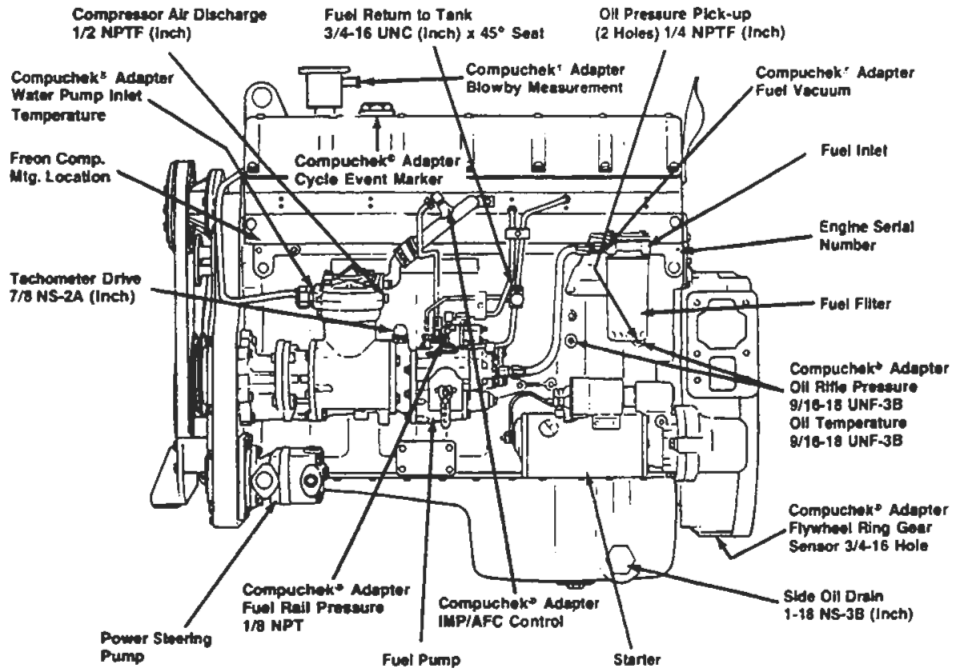

OPTIMIZED AFTERCOOLING

ew200gw

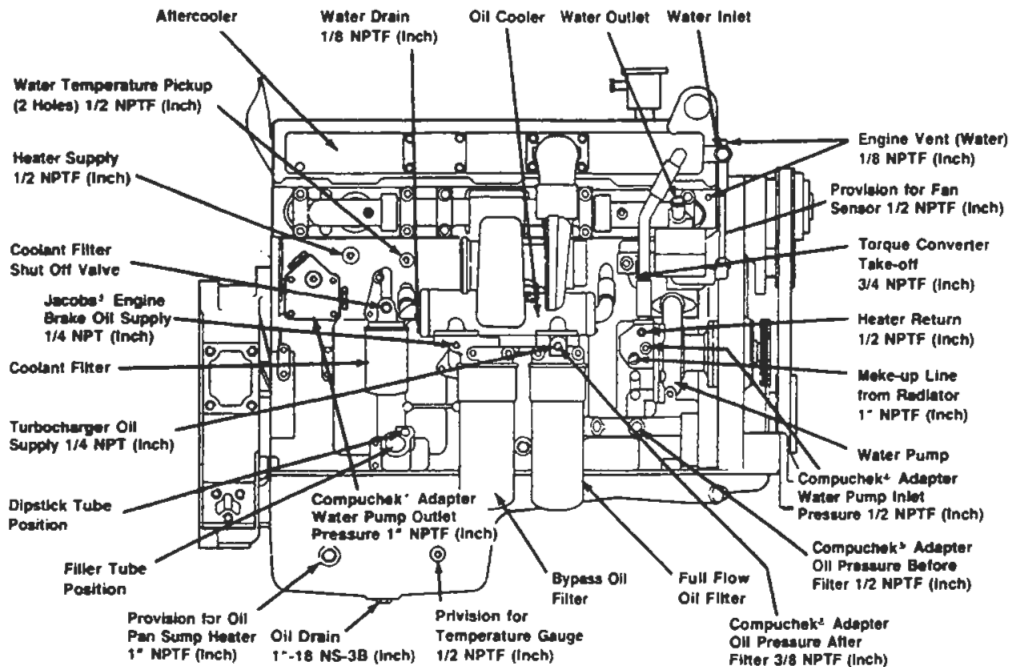

OPTIMIZED AFTERCOOLING

ew200gz

General Cleaning Instructions

Solvent And Acid Cleaning

Several solvent and acid type cleaners can be used to clean the engine parts. **Cummins Engine Co., Inc. does not recommend any specific cleaners.** Always follow the cleaner manufacturer's instructions.

Experience has shown that the best results can be obtained using a cleaner that can be heated to 90 to 95 degrees Celsius [180 to 200 degrees Fahrenheit]. A cleaning tank that provides a constant mixing and filtering of the cleaning solution will give the best results.

Remove all the gasket material, o-rings, and the deposits of sludge, carbon, etc., with a wire brush or scraper before putting the parts in a cleaning tank. Be careful not to damage any gasket surfaces. When possible, steam clean the parts before putting them in the cleaning tank.

 **Warning: The use of acid can be extremely dangerous to personnel and can damage the machinery. Always provide a tank of strong soda water as a neutralizing agent.**

Rinse all of the parts in hot water after cleaning. Dry completely with compressed air. Blow the rinse water from all of the capscrew holes and the oil drillings.

If the parts are not to be used immediately after cleaning, dip them in a suitable rustproofing compound. The rustproofing compound must be removed from the parts before installation on the engine.

Steam Cleaning

Steam cleaning can be used to remove all types of dirt that can contaminate the cleaning tank. It is a good way to clean the oil drillings.

 **Warning: Wear protective clothing to prevent personal injury from the high pressure and extreme heat.**

Do not steam clean the following parts:

1. Electrical Components
2. Wiring
3. Injectors
4. Fuel Pump
5. Belts and Hoses
6. Bearings

Glass Bead Cleaning

Glass bead cleaning can be used on many engine components to remove carbon deposits. The cleaning process is controlled by the size of the glass beads, the operating pressure, and the cleaning time.

 **Caution: Do not use glass bead cleaning on aluminum piston skirts or ring grooves. Small particles of glass will embed in the aluminum and result in premature wear. Valves, turbocharger shafts, etc., can also be damaged. Follow the cleaning directions listed in the procedures.**

Plastic Bead Cleaning

A new plastic bead media, Part No. 3822735, has been released for piston cleaning. This media can be used to clean the piston dome or crown, the ni-resist ring grooves and the aluminum ring grooves. As with walnut shell or glass bead blasting, plastic bead blasting must be done at the minimum pressure that is effective (276 kPa [40 psi]) and the spray must not be concentrated in any one area for an extended period of time.