

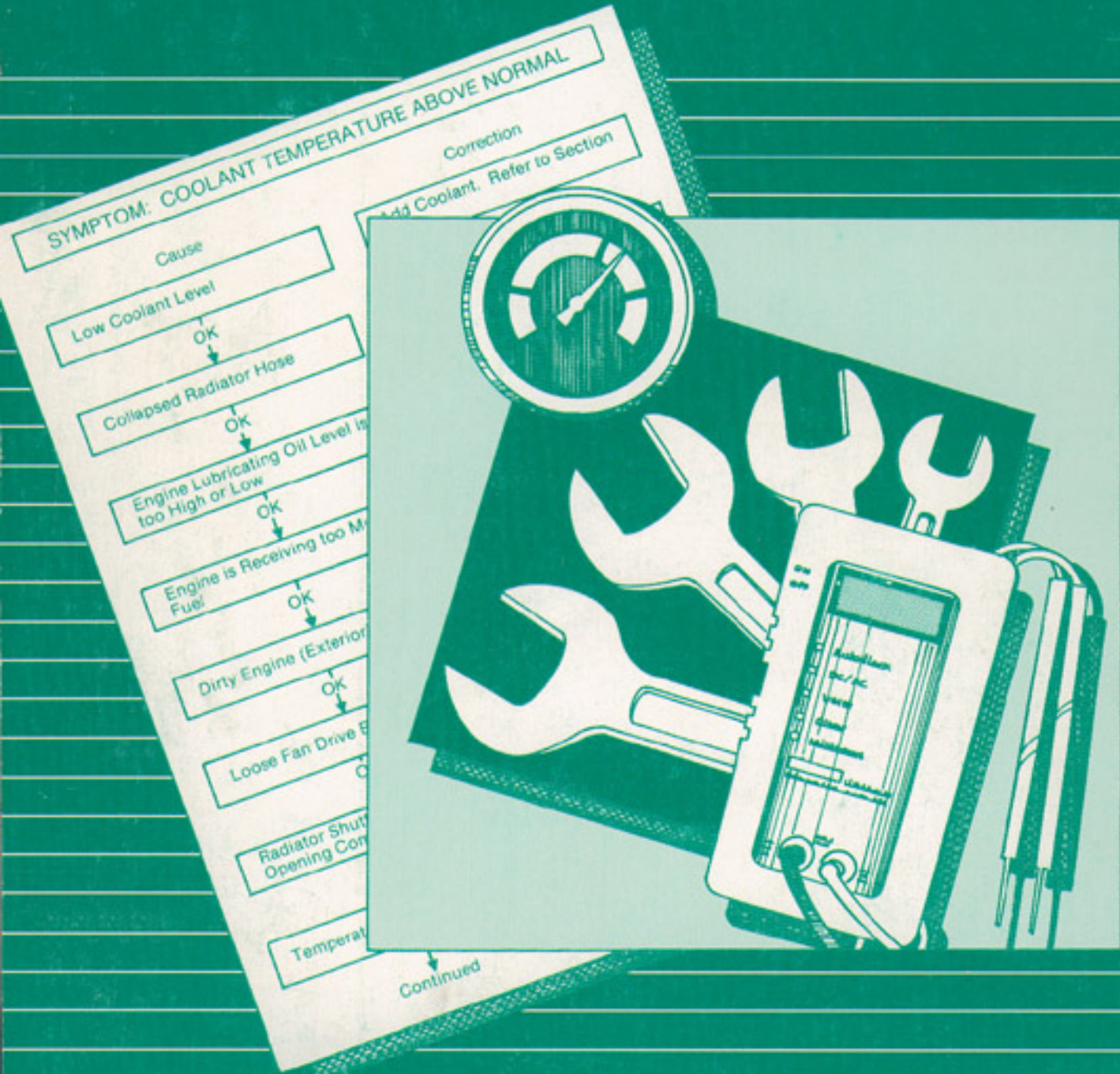

# Troubleshooting and Repair Manual B Series Engines 1991 and 1994 Certification Levels





# Troubleshooting and Repair Manual B Series Engines

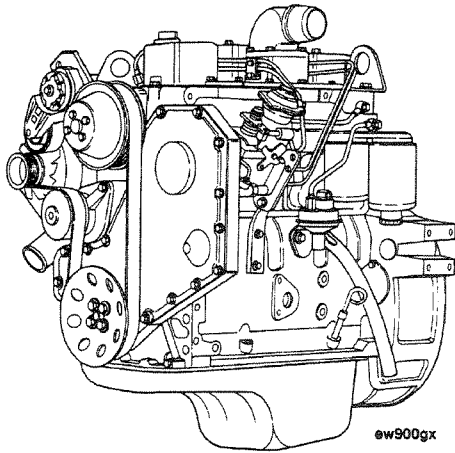

**Four Cylinder**

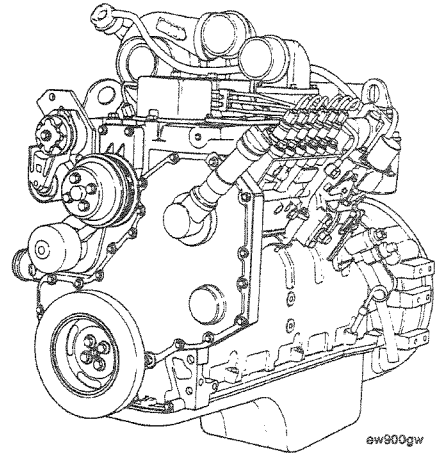

**Six Cylinder**

## Foreword

This manual provides instructions for troubleshooting and repairing the B Series Engine in the chassis. Component and assembly rebuild procedures are provided in the B Series Engine Shop Manual. Refer to Page i-2 in the Introduction for instructions on how to use this manual. The procedures given in this manual are applicable for the B Series engines produced in 1991 and newer. Refer to Bulletin No. 3810207 to find the procedures applicable to B Series engines introduced prior to 1991.

The manual is organized to guide a service technician through the logical steps of identifying and correcting problems related to the engine.

This manual does **not** cover vehicle or equipment problems. Consult the vehicle or equipment manufacturer for repair procedures.

A series of specific service manuals (Shop, Specifications, Alternative Repair, and so on.) are available and can be ordered by filling out and mailing the Literature Order Form located in the Service Literature Section L.

The repair procedures used in this manual are recommended by Cummins Engine Co., Inc. Some service procedures require the use of special service tools. Use the correct tools as described.

Reporting of errors, omissions, and recommendations for improving this publication by the user is encouraged. Please use the postage paid, self-addressed Literature Survey Form in the back of this manual for communicating your comments.

The specifications and rebuild information in this manual is based on the information in effect at the time of printing. Cummins Engine Company, Inc. reserves the right to make any changes at any time without obligation. If differences are found between your engine and the information in this manual, contact a Cummins Authorized Repair Location, a Cummins Division Office, or the factory.

The latest technology and the highest quality components are used to manufacture Cummins engines. When replacement parts are needed, we recommend using only genuine Cummins or ReCon® exchange parts. These parts can be identified by the following trademarks:



# Table of Contents

	Section
Introduction .....	i
Engine Identification .....	E
Troubleshooting .....	T
Cooling System Repair .....	1
Lubricating Oil System Repair .....	2
Air Combustion System Repair .....	3
Compressed Air System Repair .....	4
Fuel System Repair .....	5
Electrical System Repair .....	6
Base Engine Components System Repair .....	7
Engine Testing and Run-In .....	8
Engine Removal and Installation .....	9
Specifications and Torque Values .....	V
Component Manufacturers .....	C
Additional Service Literature .....	L
Index .....	X



# Section i - Introduction

## Section Contents

	<b>Page</b>
About the Manual.....	i-2
Definition of Terms .....	i-8
<b>General Cleaning Instructions</b> .....	i-10
Glass or Plastic Bead Cleaning .....	i-10
Solvent and Acid Cleaning .....	i-10
Steam Cleaning .....	i-10
<b>General Repair Instructions</b> .....	i-11
<b>General Safety Instructions</b> .....	i-9
Important Safety Notice .....	i-9
<b>How to Use the Manual</b> .....	i-2
<b>Illustrations</b> .....	i-7
<b>Symbols</b> .....	i-3

## About the Manual

This B Series Troubleshooting and Repair Manual is intended to aid in determining the cause of engine-related problems and to provide recommended repair procedures. The manual is divided into sections by system. Each section provides general information, specifications, diagrams, and service tools, where applicable. The specific repair procedures are referenced in the Troubleshooting Logic Charts.

## How to Use the Manual

The manual is organized to provide an easy flow from problem identification to problem correction. A list of troubleshooting symptoms containing the most common engine problems is on Page T-2 in the Troubleshooting Section. Complete the following steps to locate and correct the problem:

- (STEP 1.) Locate the symptom on the list.  
Reference is made to the procedure number where the "Troubleshooting Logic Chart" is found.
- (STEP 2.) The left column of the "Troubleshooting Logic Chart" indicates a probable cause, starting at the top with the simplest and easiest to repair, and continuing downward to the most difficult.  
The right column provides a brief description of the corrective action with the reference number for the repair.
- (STEP 3.) Locate the probable cause in the left column, and then turn to the procedure number in the right column.  
The repair procedures are listed by system (Cooling, Lubricating Oil, Combustion Air, Compressed Air, Fuel, Electrical, and Base Engine Components).
- (STEP 4.) The Troubleshooting Logic Charts are based on the following assumptions:
1. The engine has been installed according to the manufacturer's specifications.
  2. The easiest repairs are done first.
  3. "Generic" solutions to cover problems with the most common applications and Original Equipment Manufacturers (OEM's).

## Symbols

The following symbols have been used in this manual to help communicate the intent of the instructions. When one of the symbols appears, it conveys the meaning defined below:



**WARNING** - Serious personal injury or extensive property damage can result if the warning instructions are **not** followed.



**CAUTION** - Minor personal injury can result or a part, an assembly, or the engine can be damaged if the caution instructions are **not** followed.



Indicates a **REMOVAL** or **DISASSEMBLY** step.



Indicates an **INSTALLATION** or **ASSEMBLY** step.



**INSPECTION** is required.



**CLEAN** the part or assembly.



**PERFORM** a mechanical or time **MEASUREMENT**.



**LUBRICATE** the part or assembly.



Indicates that a **WRENCH** or **TOOL SIZE** will be given.



**TIGHTEN** to a specific torque.



**PERFORM** an electrical **MEASUREMENT**.



Refer to another location in this manual or another publication for additional information.



The component weighs 23 kg [50 lb] or more. To avoid personal injury, use a hoist or get assistance to lift the component.



## Simbolos

Los símbolos siguientes son usados en este manual para clarificar el proceso de las instrucciones. Cuando aparece uno de estos símbolos, su significado se especifica en la parte inferior.



**ADVERTENCIA** - Serios daños personales o daño a la propiedad puede resultar si las instrucciones de Advertencia **no** se consideran.



**PRECAUCION** - Daños menores pueden resultar, o de piezas del conjunto o el motor puede averiarse si las instrucciones de Precaución **no** se siguen.



Indica un paso de **REMOCION** o **DESMONTAJE**.



Indica un paso de **INSTALACION** o **MONTAJE**.



Se requiere **INSPECCION**.



**LIMPIESE** la pieza o el montaje.



**EJECUTESE** una **MEDICION** mecánica o del tiempo.



**LUBRIQUESE** la pieza o el montaje.



Indica que se dará una **LLAVE DE TUERCAS** o el **TAMAÑO DE HERRAMIENTA**.



**APRIETESE** hasta un par torsor específico.



**EJECUTESE** una **MEDICION** eléctrica.



Para información adicional refiérase a otro emplazamiento de este manual o a otra publicación anterior.



El componente pesa 23 kg [50 lb] o mas. Para evitar dano corporal empleen una cabria u obtengan ayuda para elevar el componente.

## Symbole

In diesem Handbuch werden die folgenden Symbole verwendet, die wesentliche Funktionen hervorheben. Die Symbole haben folgende Bedeutung:



**WARNUNG** - Wird die Warnung **nicht** beachtet, dann besteht erhöhte Unfall- und Beschädigungsgefahr.



**VORSICHT** - Werden die Vorsichtsmassnahmen **nicht** beachtet, dann besteht Unfall- und Beschädigungsgefahr.



**AUSBAU** bzw. **ZERLEGEN**.



**EINBAU** bzw. **ZUSAMMENBAU**.



**INSPEKTION** erforderlich.



Teil oder Baugruppe **REINIGEN**.



**DIMENSION** - oder **ZEITMESSUNG**.



Teil oder Baugruppe **ÖLEN**.



**WERKZEUGGRÖSSE** wird angegeben.



**ANZUG** auf vorgeschriebenes Drehmoment erforderlich.



Elektrische **MESSUNG DURCHFÜHREN**.



Weitere Informationen an anderer Stelle bzw. in anderen Handbüchern.



Das teil weigt 23 kg [50 lb] oder mehr. Zur vermeidung von koerperverletzung winde benutzen oder hilfe beim heben des teils in anspruch nehmen.

## Symboles

Les symboles suivants sont utilisés dans ce manuel pour aider à communiquer le but des instructions. Quand l'un de ces symboles apparaît, il évoque le sens défini ci-dessous:



**AVERTISSEMENT** - De graves lésions corporelles ou des dommages matériels considérables peuvent survenir si les instructions données sous les rubriques "Avertissement" ne sont pas suivies.



**ATTENTION** - De petites lésions corporelles peuvent survenir, ou bien une pièce, un ensemble ou le moteur peuvent être endommagés si les instructions données sous les rubriques "Attention" ne sont pas suivies.



Indique une opération de **DEPOSE**.



Indique une opération de **MONTAGE**.



**L'INSPECTION** est nécessaire.



**NETTOYER** la pièce ou l'ensemble.



**EFFECTUER** une **MESURE** mécanique ou de temps.



**GRAISSER** la pièce ou l'ensemble.



Indique qu'une **DIMENSION DE CLE** ou **D'OUTIL** sera donnée.



**SERRER** à un couple spécifique.



**EFFECTUER** une **MESURE** électrique.



Se reporter à un autre endroit dans ce manuel ou à une autre publication pour obtenir des informations plus complètes.



Le composant pèse 23 kg [50 lb] ou davantage. Pour éviter toute blessure, employer un appareil de levage ou demander de l'aide pour le soulever.

## Illustrations

The illustrations used in the "Repair Sections" of this manual are intended to give an example of a problem, and to show what to look for and where the problem can be found. Some of the illustrations are "generic" and will **not** look exactly like the engine or parts used in your application. Some illustrations contain symbols to indicate an action required, and an acceptable or **not** acceptable condition.

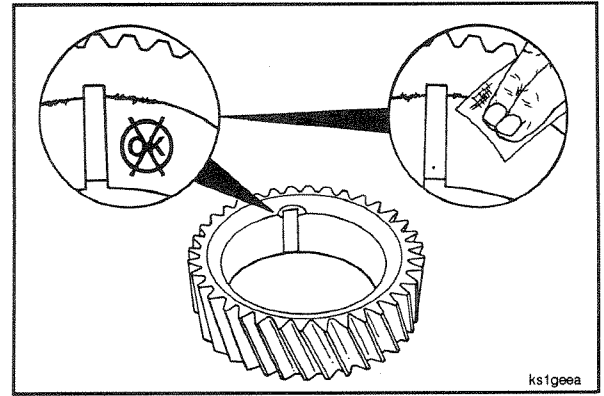

The illustrations are intended to show repair or replacement procedures with the engine "in-chassis." The illustration can differ from your application, but the procedure given will be the same.

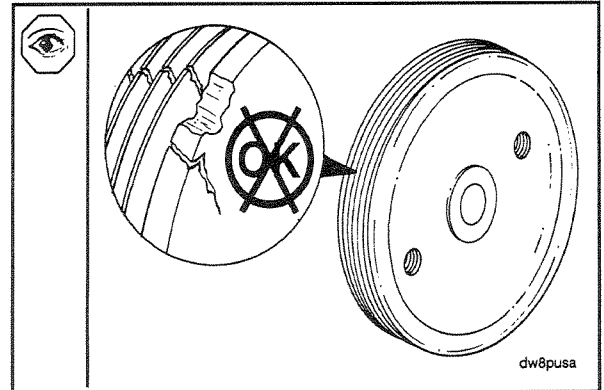

## Definition of Terms

<b>AFC</b>	Air Fuel Control	<b>in-lb</b>	Inch Pound
<b>API</b>	American Petroleum Institute	<b>kg</b>	Kilograms
<b>ASA</b>	Air Signal Attenuator	<b>km</b>	Kilometers
<b>ASTM</b>	American Society of Testing and Materials	<b>km/l</b>	Kilometers per Liter
<b>C</b>	Celsius	<b>kPa</b>	Kilopascal
<b>CARB</b>	California Air Resources Board	<b>l</b>	Liter
<b>C.I.D.</b>	Cubic Inch Displacement	<b>m</b>	Meter
<b>Cm</b>	Centimeter	<b>mm</b>	Millimeter
<b>CPL</b>	Control Parts List	<b>MPa</b>	Megapascal
<b>cSt</b>	Centistokes	<b>MPH</b>	Miles Per Hour
<b>DCA</b>	Diesel Coolant Additive	<b>MPQ</b>	Miles Per Quart
<b>ECM</b>	Electronic Control Module	<b>N•m</b>	Newton-meter
<b>E.C.S.</b>	Emission Control System	<b>OEM</b>	Original Equipment Manufacturer
<b>EPA</b>	Environmental Protection Agency	<b>ppm</b>	Parts Per Million
<b>EPS</b>	Engine Position Sensor	<b>psi</b>	Pounds Per Square Inch
<b>F</b>	Fahrenheit	<b>PTO</b>	Power Takeoff
<b>ft-lb</b>	Foot Pound	<b>RPM</b>	Revolutions Per Minute
<b>GVW</b>	Gross Vehicle Weight	<b>S.A.E.</b>	Society of Automotive Engineers
<b>Hg</b>	Mercury	<b>STC</b>	Step Timing Control
<b>HP</b>	Horsepower	<b>VS</b>	Variable Speed
<b>H<sub>2</sub>O</b>	Water	<b>VSS</b>	Vehicle Speed Sensor

## General Safety Instructions

### Important Safety Notice



Read and understand all of the safety precautions and warnings before performing any repair. This list contains the general safety precautions that **must** be followed to provide personal safety. Special safety precautions are included in the procedures when they apply.

- Make sure the work area surrounding the product is safe. Be aware of hazardous conditions that can exist.
- **Always** wear protective glasses and protective shoes when working.
- Do **not** wear loose-fitting or torn clothing. Remove all jewelry when working.
- Disconnect the battery and discharge any capacitors before beginning any repair work. Disconnect the air starting motor if equipped to prevent accidental engine starting. Put a "Do Not Operate" tag in the operator's compartment or on the controls.
- Use **ONLY** the proper engine barring techniques for manually rotating the engine. Do **not** attempt to rotate the engine by pulling or prying on the fan. This practice can cause serious personal injury, property damage, or damage to the fan blade(s) causing premature fan failure.
- If an engine has been operating and the coolant is hot, allow the engine to cool before you slowly loosen the filler cap and relieve the pressure from the cooling system.
- Do **not** work on anything that is supported **ONLY** by lifting jacks or a hoist. **Always** use blocks or proper stands to support the product before performing any service work.
- Relieve all pressure in the air, oil, and the cooling systems before any lines, fittings, or related items are removed or disconnected. Be alert for possible pressure when disconnecting any device from a system that utilizes pressure. Do **not** check for pressure leaks with your hand. High pressure oil or fuel can cause personal injury.
- To prevent suffocation and frostbite, wear protective clothing and **ONLY** disconnect liquid refrigerant (freon) lines in a well ventilated area.
- To avoid personal injury, use a hoist or get assistance when lifting components that weigh 23 kg [50 lb] or more. Make sure all lifting devices such as chains, hooks, or slings are in good condition and are of the correct capacity. Make sure hooks are positioned correctly. **Always** use a spreader bar when necessary. The lifting hooks **must not** be side-loaded.
- Corrosion inhibitor contains alkali. Do **not** get the substance in your eyes. Avoid prolonged or repeated contact with skin. Do **not** swallow internally. In case of contact, immediately wash skin with soap and water. In case of contact, immediately flood eyes with large amounts of water for a minimum of 15 minutes. **IMMEDIATELY CALL A PHYSICIAN. KEEP OUT OF REACH OF CHILDREN.**
- Naptha and Methyl Ethyl Ketone (MEK) are flammable materials and **must** be used with caution. Follow the manufacturer's instructions to provide complete safety when using these materials. **KEEP OUT OF REACH OF CHILDREN.**
- To avoid burns, be alert for hot parts on products that have just been turned OFF, and hot fluids in lines, tubes, and compartments.
- **Always** use tools that are in good condition. Make sure you understand how to use them before performing any service work. Use **ONLY** genuine Cummins or Cummins Recon® replacement parts.
- **Always** use the same fastener part number (or equivalent) when replacing fasteners. Do **not** use a fastener of lesser quality if replacements are necessary.

## General Cleaning Instructions

### Solvent and Acid Cleaning

Several solvent and acid-type cleaners can be used to clean the engine parts. **Cummins Engine Company, Inc. does not recommend any specific cleaners. Always** follow the cleaner manufacturer's instructions.

Experience has shown that the best results can be obtained using a cleaner that can be heated to 90 to 95 degrees Celsius [180 to 200 degrees Fahrenheit]. A cleaning tank that provides a constant mixing and filtering of the cleaning solution will give the best results.



Remove all the gasket material, o-rings, and the deposits of sludge, carbon, etc., with a wire brush or scraper before putting the parts in a cleaning tank. Be careful **not** to damage any gasket surfaces. When possible, steam clean the parts before putting them in the cleaning tank.

**Warning:** The use of acid can be extremely dangerous to personnel, and can damage the machinery. Always provide a tank of strong soda water as a neutralizing agent.

Rinse all of the parts in hot water after cleaning. Dry completely with compressed air. Blow the rinse water from all of the capscrew holes and the oil drillings.

If the parts are **not** to be used immediately after cleaning, dip them in a suitable rustproofing compound. The rustproofing compound **must** be removed from the parts before installation on the engine.

### Steam Cleaning

Steam cleaning can be used to remove all types of dirt that can contaminate the cleaning tank. It is a good way to clean the oil drillings.

**Warning:** Wear protective clothing to prevent personal injury from the high pressure and extreme heat.

Do **not** steam clean the following parts:



1. Electrical Components
2. Wiring
3. Injectors
4. Fuel Pump
5. Belts and Hoses
6. Bearings

### Glass or Plastic Bead Cleaning

Glass or plastic bead cleaning can be used on many engine components to remove carbon deposits. The cleaning process is controlled by the size of the glass or plastic beads, the operating pressure, and the cleaning time.

**Caution:** Do not use glass or plastic bead cleaning on aluminum piston skirts. Do not use glass bead cleaning on aluminum ring grooves. Small particles of glass or plastic will embed in the aluminum and result in premature wear. Valves, turbocharger shafts, etc., can also be damaged. Follow the cleaning directions listed in the procedures.



**NOTE:** Plastic bead blasting media, Part No. 3822735, can be used to clean aluminum ring grooves. Do not use any bead blasting media on pin bores or aluminum skirts.

Follow the equipment manufacturer's cleaning instructions. The following guidelines can be used to adapt to manufacturer's instructions:

1. Bead size:
  - Use U.S. size No. 16-20 for piston cleaning with plastic bead media, Part No. 3822735.
  - Use U.S. size No. 70 for piston domes with glass media.
  - Use U.S. size No. 60 for general purpose cleaning with glass media.
2. Operating Pressure:
  - Glass: Use 620 kPa [90 psi] for general purpose cleaning.
  - Plastic: Use 270 kPa [40 psi] for piston cleaning.
3. Steam clean or wash the parts with solvent to remove all of the foreign material and glass or plastic beads after cleaning. Rinse with hot water. Dry with compressed air.
4. Do **not** contaminate the wash tanks with glass or plastic beads.

## General Repair Instructions

This engine incorporates the latest diesel technology; yet, it is designed to be repaired using normal repair practices performed to quality standards.

- **Cummins Engine Company, Inc. does not recommend or authorize any modifications or repairs to engines or components except for those detailed in Cummins Service Information. In particular, unauthorized repair to safety-related components can cause personal injury. Below is a partial listing of components classified as safety-related:**

- Air Compressor
- Air Controls
- Air Shutoff Assemblies
- Balance Weights
- Cooling Fan
- Fan Hub Assembly
- Fan Mounting Bracket(s)
- Fan Mounting Capscrews
- Fan Hub Spindle
- Flywheel
- Flywheel Crankshaft Adapter
- Flywheel Mounting Capscrews
- Fuel Shutoff Assemblies
- Fuel Supply Tubes
- Lifting Brackets
- Throttle Controls
- Turbocharger Compressor Casing
- Turbocharger Oil Drain Line(s)
- Turbocharger Oil Supply Line(s)
- Turbocharger Turbine Casing
- Vibration Damper Mounting Capscrews

- **Follow All Safety Instructions Noted in the Procedures.**
  - Follow the manufacturer's recommendations for cleaning solvents and other substances used during the repair of the engine. **Always** use good safety practices with tools and equipment.
- **Provide A Clean Environment and Follow the Cleaning Instructions Specified in the Procedures**
  - The engine and its components **must** be kept clean during any repair. Contamination of the engine and components will cause premature wear.
- **Perform the Inspections Specified in the Procedures.**
- **Replace all Components or Assemblies Which are Damaged or Worn Beyond the Specifications**
- **Use Genuine Cummins New or ReCon® Service Parts and Assemblies**
  - The assembly instructions have been written to use again as many components and assemblies as possible. When it is necessary to replace a component or assembly, the procedure is based on the use of new Cummins or Cummins ReCon® components. All of the repair services described in this manual are available from all Cummins Distributors and most Dealer locations.
- **Follow The Specified Disassembly and Assembly Procedures to Avoid Damage to the Components.**

Complete rebuild instructions are available in the shop manual which can be ordered or purchased from a Cummins Authorized Repair Location. Refer to Section L, Literature, for ordering instructions.





# Section E - Engine Identification

## Section Contents

	Page
<b>Automotive Engine Specifications</b> .....	E-4
<b>Engine Diagrams</b> .....	E-8
Front View .....	E-9
Fuel Pump Side View.....	E-8
Rear View.....	E-8
Turbocharger Side View .....	E-9
<b>Engine Identification</b> .....	E-2
Engine Dataplate .....	E-2
Engine Nomenclature.....	E-2
<b>Fuel Pump Dataplate (Nameplate)</b> .....	E-3
<b>Non-Automotive Engine Specifications</b> .....	E-7

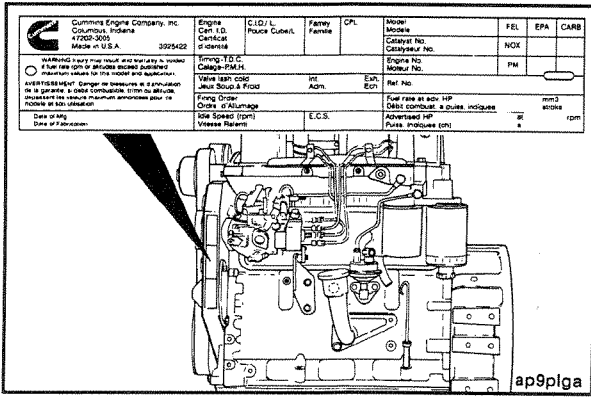

## Engine Identification

### Engine Dataplate

The engine dataplate shows specific information about your engine. The engine serial number (1) and Control Parts List (CPL) (2) provide information for ordering parts and service needs.

<p>Cummins Engine Company, Inc. Columbus, Indiana 47202-3005 Made in U.S.A. 3925422</p> <p><b>WARNING</b> Injury may result and warranty is voided if fuel rate rpm or altitudes exceed published maximum values for this model and application.</p> <p><b>AVERTISSEMENT:</b> Danger de blessures et d'annulation de la garantie, si débit combustible, tr/mn ou altitude, dépassent les valeurs maximum annoncées pour ce modèle et son utilisation.</p> <p>Date of Mfg. Date of Fabrication</p>	<p>Engine Cert. I.D. Certificat d'identité</p>	<p>C.I.D./ L. Pouce Cube/L</p>	<p>Family Famille</p>	<p>CPL</p>	<p>Model Modele</p>	<p>FEL</p>	<p>EPA</p>	<p>CARB</p>
	<p>Timing-T.D.C. Calage-P.M.H.</p>	<p>Valve lash cold Jeux Soup.à Froid</p>	<p>Int. Adm.</p>	<p>Exh. Ech</p>	<p>Engine No. Moteur No.</p>	<p>NOX</p>		
	<p>Firing Order Ordre d'Allumage</p>	<p>Idle Speed (rpm) Vitesse Ralenti</p>	<p>E.C.S.</p>	<p>Fuel rate at adv. HP Débit combust. à puiss. indiquée</p>	<p>Ref. No.</p>	<p>PM</p>		
				<p>Advertised HP Puiss. Indiquée (ch)</p>	<p>at a</p>	<p>mm3 stroke</p>		<p>rpm</p>

2

1

ap9plgb

## Engine Nomenclature

The model name for engines in automotive applications provides the data shown in the example.

### Example

**B 3.9-105**

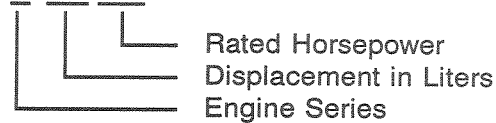

The following example shows a model name of an engine for non-automotive applications.

### Example

**4 B T A 3.9**

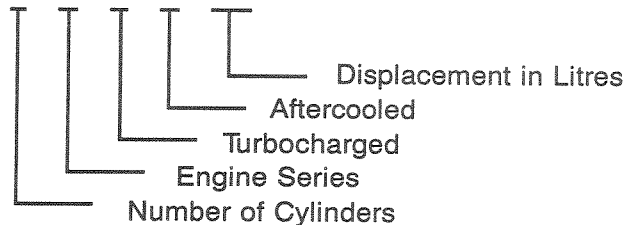

### Fuel Pump Dataplate (Nameplate)

The fuel pump dataplate is located on the side of the fuel pump. It provides information for fuel pump calibration. This illustration shows the dataplate location on a Bosch rotary injection pump.

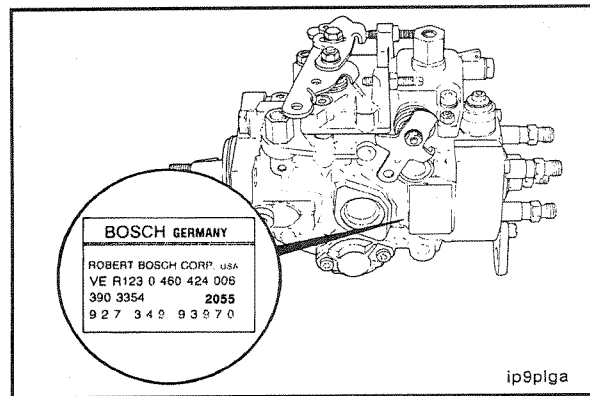

This illustration shows the dataplate location and a Lucas CAV rotary injection pump.

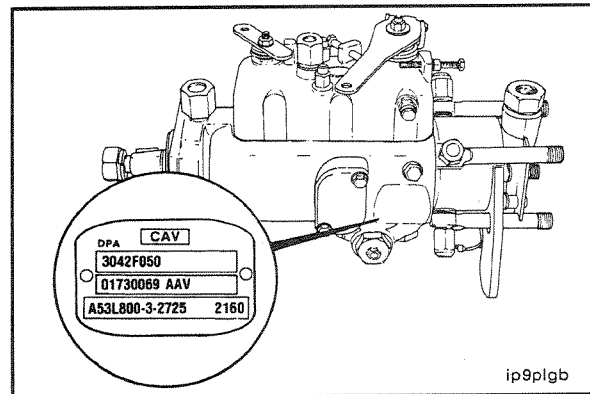

This illustration shows the dataplate location on a Bosch in-line injection pump. The Nippondenso EP-9 dataplate is located in approximately the same location as the illustrated Bosch dataplate.

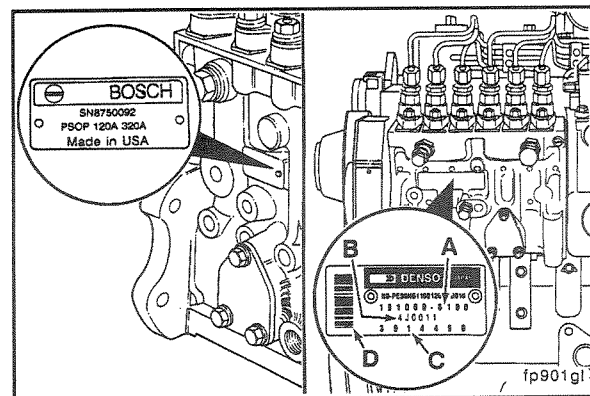

The Cummins part number for the in-line pump and governor combination is located on the governor dataplate.

