

SELF-PROPELLED
ELEVATING WORK PLATFORM

MODEL V2648XL, V2648

Serial Number X51597001

MODEL V2653XL, V2653

Serial Number X53597001

OPERATOR'S, MAINTENANCE.
ILLUSTRATED PARTS MANUAL

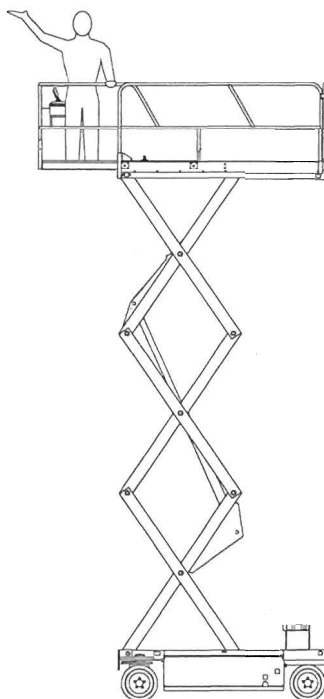

SHIPPING ADDRESS

CONDOR®

TIME CONDOR Corporation
8300 IMPERIAL DRIVE
WACO, TEXAS 76712
(254) 420-5200

MAILING ADDRESS

CONDOR®

TIME CONDOR Corporation
P.O. Box 21447
WACO, TEXAS 76702-1447
(254) 420-5200

CONDOR

TIME CONDOR Corporation



SELF-PROPELLED
ELEVATING WORK PLATFORM

MODEL V2648XL, V2648

Serial Number X51597001

MODEL V2653XL, V2653

Serial Number X53597001

OPERATOR'S MANUAL

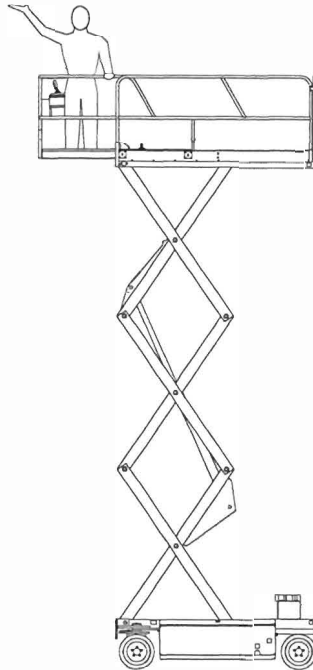

SHIPPING ADDRESS

CONDOR®

TIME CONDOR Corporation
8300 IMPERIAL DRIVE
WACO, TEXAS 76712
(254) 420-5200

MAILING ADDRESS

CONDOR®

TIME CONDOR Corporation
P.O. Box 21447
WACO, TEXAS 76702-1447
(254) 420-5200

INTRODUCTION

The primary purpose of this manual is to provide the user with a thorough understanding of the proper operating procedures necessary to comply with the intended use of the **CONDOR®**.

THIS MANUAL MUST BE RETAINED ON THE CONDOR® AT ALL TIMES.

Do not attempt to operate this CONDOR® until you have read and understood all information provided in this manual. Familiarize yourself with the functions and operations of the upper and lower controls. A good understanding of the controls, their limitations, and their capabilities will maximize operating efficiency. The various decals attached to this CONDOR® contain vital information. Read all decals before operating this CONDOR®.

It is YOUR RESPONSIBILITY to follow procedures while operating this **CONDOR®**. The manufacturer of this **CONDOR®** cannot control the wide range of applications that may be used in carrying out a variety of jobs. Therefore, IT IS THE USER'S RESPONSIBILITY to consider all of the personnel when making decisions regarding the intended use of this **CONDOR®**.

It is also YOUR RESPONSIBILITY to understand and obey all federal, state, and local regulations regarding the operation and use of aerial work platforms. A copy of the ANSI/SIA A92.6-1990 Manual of Responsibilities is attached for your use.

TIME CONDOR Corporation reserves the right to modify, improve, add, and/or delete certain design features of its products without any obligation to incorporate new features into products previously sold. Manuals are continually updated to reflect these changes.

DO NOT ALTER OR MODIFY THIS CONDOR® WITHOUT PRIOR WRITTEN APPROVAL FROM THE MANAGEMENT OF TIME CONDOR CORPORATION.

SERVICE & MAINTENANCE

Many of the parts used in the manufacture of this **CONDOR®** have specific properties, and the manufacturer recommends that replacement parts be purchased through TIME CONDOR Corporation in order to ensure the original integrity of the product. Repairs and adjustments should only be made by trained and qualified personnel. Please refer to the maintenance and parts sections of the TIME CONDOR Corporation Operation, Parts & Maintenance Manual for information on service and maintenance of this **CONDOR®**.



TIME CONDOR Corporation
CONDOR® SERVICE INFORMATION

1. If you need assistance or have any service or maintenance questions, TIME CONDOR Corporation service and parts personnel are always available by phone or fax. The telephone numbers are:

(254) 420-5200 Telephone
(254) 420-5298 Voice Mail
(800) 443-5803 FAX
2. There are numerous written Maintenance Procedures available for this CONDOR®. These procedures are available through the TIME CONDOR Corporation Service Department to anyone who requests them.
3. Service and maintenance are not a substitute for trained, qualified service technicians. TIME CONDOR Corporation conducts service schools on a continuing basis. Call any of our service or sales persons for a schedule. Remember, training of mechanics is the responsibility of their employer, but TIME CONDOR Corporation Service Schools help you provide this training.
4. TIME CONDOR Corporation Service School Training Manuals are available for purchase through the parts department. The part numbers for these manuals are: #92333 for self-propelled models; and #92334 for truck-mounted models.

TABLE OF CONTENTS

INTRODUCTION i
SERVICE INFORMATION ii
TABLE OF CONTENTS iii

I. PREPARATION, INSPECTION, AND MAINTENANCE 1

A. Overall Machine Condition 1
B. Lower Control Station 1
C. Emergency Lowering 1
D. Platform and Upper Control Station 2
E. Hydraulic System 2
F. Batteries 2

II. MACHINE OPERATION 2

A. Rated Work Load 2
B. Lower Controls 2
C. Upper Controls 3
D. Emergency Lowering 3
E. Lift-up Entry Gate 3
F. Deck Extension 5
G. Removable Upper Control Box 5

III. MOVING FROM JOB-SITE TO JOB-SITE 5

A. Loading and Unloading 5
B. Ramp Method 5
C. Forklift Loading and Unloading Method 5
D. Transporting 6
E. Freewheel Operation 6

IV. STORAGE 6

APPENDIX: DECALS ILLUSTRATION 8

ANSI/SIA A92.6 - 1990 MANUAL OF RESPONSIBILITIES

IMPORTANT: A COPY OF THE ANSI/SIA A92.6 - 1990 MANUAL OF RESPONSIBILITIES IS ATTACHED TO THIS OPERATOR'S MANUAL. IT CONTAINS IMPORTANT OPERATING INFORMATION FOR THIS CONDOR®. READ IT BEFORE OPERATING THIS CONDOR®.

I. PREPARATION, INSPECTION, AND MAINTENANCE

The condition of this CONDOR® is very important, as it directly affects the operator as well as others. The operator must perform a thorough walk-around inspection each day prior to operating the CONDOR®. Any damage or faulty operation should be reported immediately.

A **DO NOT OPERATE** tag outlining the problem should be attached to the lower control station and any discrepancies should be corrected before operating this CONDOR®.

KNOW THIS CONDOR® AND ITS CAPABILITIES. REPORT ANY UNUSUAL OPERATION, SUCH AS ERRATIC SWAY OR MOTION OF THE ARMS OR PLATFORM.

Some major areas to check daily are:

A. OVERALL MACHINE CONDITION

MISSING, BROKEN, OR DAMAGED PARTS:

- Check cylinder mounting pins, pivot pins, pin retainers, bearing pads, bolts, and nuts.

STRUCTURAL:

- Check for damaged or cracked welds on structural components-arms, platform, chassis.

TIRES AND WHEELS:

- Check for cracks, tears, cuts, or missing or loose lug nuts (a rust line running down the rim from the lug nut indicates a loose lug nut).

STEERING:

- Check steering link to knuckle connections and steering cylinder for proper and secure mounting.

BRAKES:

- Check for abnormal wear between deadbolts and hubs, and for loose or missing bolts, nuts, and pins.

DECALS:

- Check that all decals and warning signs are in place and are clearly legible.

CAUTION

Defective components, structural damage, missing parts, and equipment malfunction jeopardize the operator and other personnel and may cause excessive damage to the unit. A poorly maintained CONDOR® could become the greatest operational hazard you may encounter.

B. LOWER CONTROLS

- Check that all functions operate properly, that switches return freely to neutral position. Do not operate the CONDOR® with sticking controls

C. EMERGENCY LOWERING

- Check emergency lowering function by pulling red T-handle.

D. PLATFORM AND UPPER CONTROL STATION

- Check that lift-up entry gate is functional and that chain is secure.
- Re-check the structural condition of the platform—pins, railings, and floor.
- Check for missing bolts & nuts - Replace before operating.
- Check that extension deck is locked in place.
- Check function of red button. It disconnects power to the controls and, when pushed, stops all powered functions.
- Check that drive control lever returns freely to neutral.

E. HYDRAULIC SYSTEM

- Check the hydraulic tank fluid level with the platform all the way down. Fluid must be visible in sight glass. Add Shell Tellus T-32 Hydraulic Fluid if required. Ensure that the breather cap is clean and in place on the tank.
- Check for hydraulic leaks at all fittings and valves.
- Check all hydraulic hoses and tubes for damage and kinks.

F. BATTERIES

CAUTION

Keep flame, sparks and metal away from the batteries.

- Check Electrolyte level daily in each cell. If necessary, add clear, odorless, mineral free water to bring the level to $\frac{1}{2}$ " above the top of the separators, or to the Level Indicator (if equipped), in each cell. Only add water after charging cycle is complete.

- Keep battery tops clean and dry.
- Keep vent caps tightly in place.
- Check that battery cable connections are tight and clean and free of corrosion.
- Make sure the battery charger and the indicator lights and meter are not damaged.

II. CONDOR® OPERATION

CAUTION

CONDOR® MUST BE OPERATED ON FIRM, LEVEL GROUND ONLY.

A. RATED WORK LOAD

The platform will support a combined weight equal to the unit's rated work load—including personnel, tools, and equipment—throughout the working envelope of the CONDOR®.

Rated work load, on extension deck only, is not to exceed 250 lbs. (113 kg) including one occupant. Total rated work load is not to exceed 1,000 lbs. (454 kg) including two occupants.

B. LOWER CONTROLS

CAUTION

ARM STAND MUST BE USED WHEN MAINTENANCE PERFORMED ON CONDOR® REQUIRES SCISSOR ARM'S TO BE RAISED.

1. To engage arm stand, raise platform, then rotate stand until it hangs vertically. Lower the platform until the arm stand rests on the cross tube on the frame. Maintenance can now begin.

2. To store arm stand, raise platform so that arm stand can be rotated until it rests on the stop provided on the scissor arms.

Turn "controls" switch to "lower" position, to operate from ground.

In an emergency, push red button. To operate, button must be pulled out. (Also, if applicable, battery disconnect switch must be "on" to operate.)

Push "raise" or "lower" switches to move platform.

Turn switch to "upper" position, to operate from platform.

C. UPPER CONTROLS

Turn "controls" switch, on lower control panel, to "upper" position to operate from platform.

NOTE:

Chain should be snapped in place across entry. Gate should be lowered and closed when operating **CONDOR®** from upper controls.

In an emergency, push red button. To operate from platform, both red buttons, on lower and upper controls, must be pulled out.

To raise and lower platform, push and hold the green "power" button, and push the "raise" or "lower" button. Release buttons to stop movement.

Select desired drive speed with the "high/low/creep" switch. (A limit switch automatically cuts drive speed to "creep" as the platform is raised.)

To drive forward or reverse, squeeze lever switch on handle, and push or pull handle in the intended direction of travel. Release lever switch to stop movement. Letting go of handle also will stop movement.

Brakes are automatically released whenever the drive handle is moved. Let go of the handle to automatically set the brakes.

To improve drive traction, depress and hold "positraction" switch. (This will automatically cut-out high drive speed.)

To steer left or right, squeeze lever switch on handle, and depress rocker switches on top of handle in the intended direction of travel. Steering is not automatically self-centering. Be sure the steering wheels point in the direction you want before letting go of the steer switch.

D. EMERGENCY LOWERING

For emergency lowering, grasp the Tee-handle located below the rear bumper. Gently pull to lower the platform. Release handle to stop lowering.

E. LIFT-UP ENTRY GATE

To load 4' wide sheets, lift entry gate up until lockpins snap in place. After loading, pull at both lockpins, to let gate fall into place. Keep gate down, except for loading and unloading.

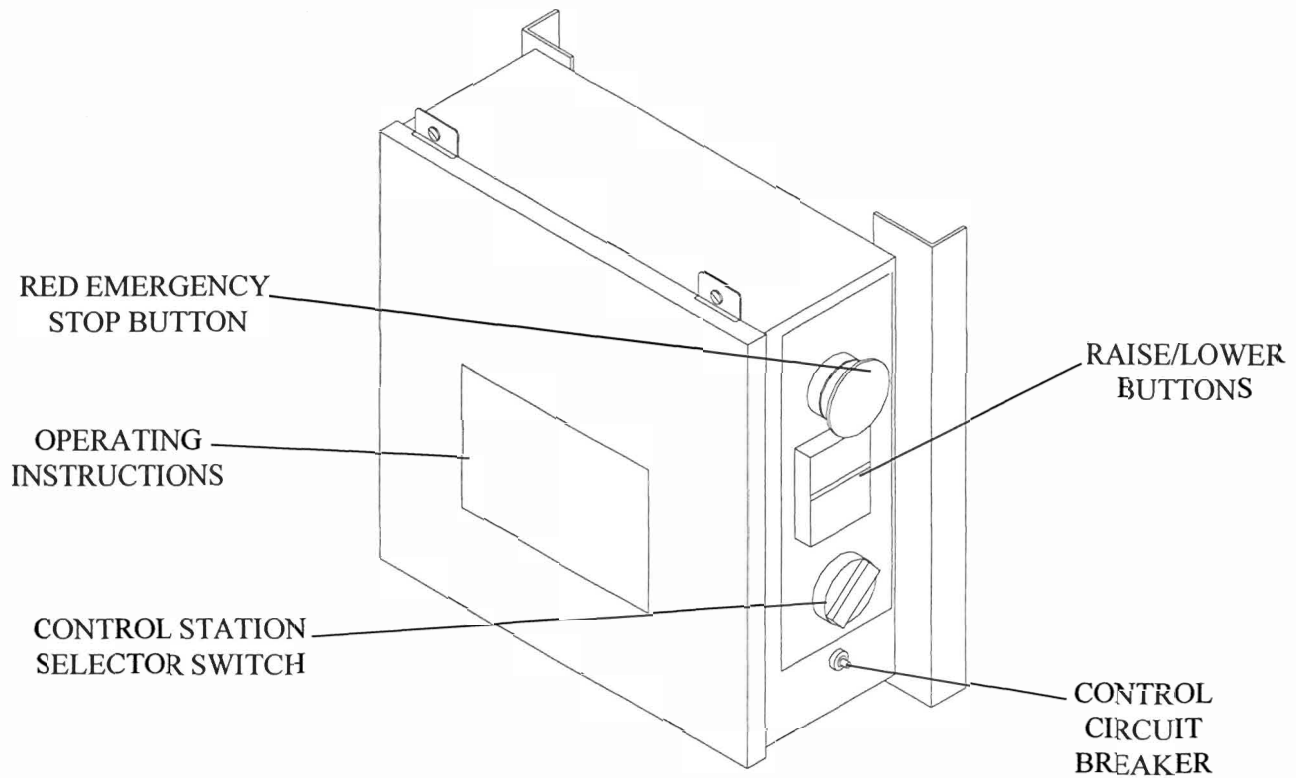
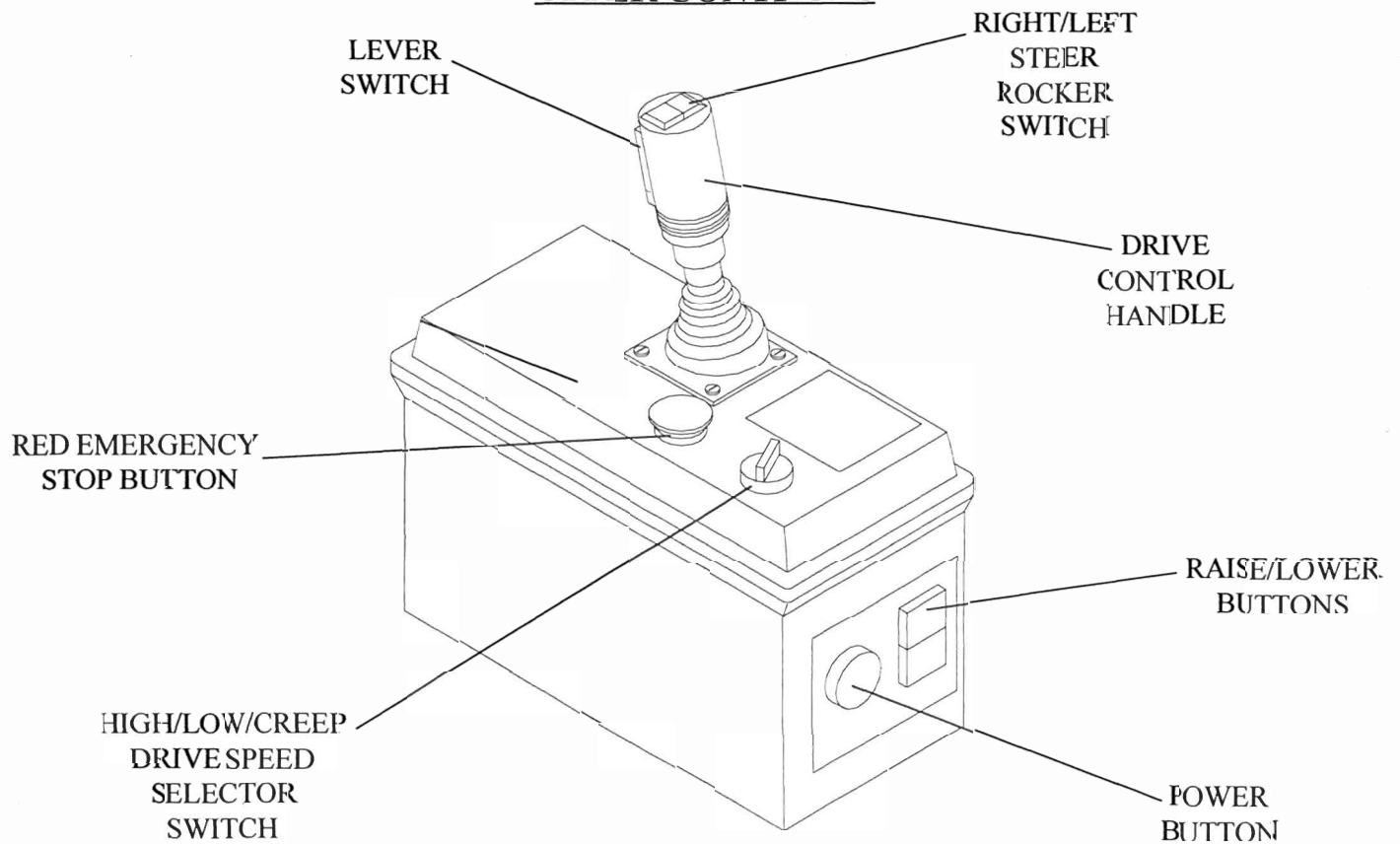
LOWER CONTROLS**UPPER CONTROLS**

F. DECK EXTENSION

Lift lockpin, at right side of deck, and push extension deck forward (or out). When fully extended, lockpin will automatically lock. To retract, lift lockpin and pull extension deck all the way back until lockpin automatically locks extension deck in place.

CAUTION
Do not lower extension deck onto people or any objects!

G. 'REMOVABLE' UPPER CONTROL BOX

Unsnap overcenter latch at bottom of upper control box and pull plug out of receptacle. Bend cable so that plug faces down. Snap cover onto receptacle at bottom of box. Lift box and store it in a secure place to prevent unauthorized use of the CONDOR®.

III. MOVING FROM JOB-SITE TO JOB-SITE

A. LOADING AND UNLOADING

Although this CONDOR® is somewhat small compared with larger construction equipment, it requires the same care and attention in loading, transporting, and unloading. At no time should its size, or weight be under estimated. Before loading or unloading, inspect the CONDOR® for any physical damage or defects.

The means by which you load or unload the CONDOR® should be of sufficient strength to withstand its weight.

| MODEL | WEIGHT(#) | WEIGHT(KG) |
|---------|-----------|------------|
| V2648 | 4400 lbs. | 1860kg |
| V2648XL | 4500 lbs. | 1905kg |
| V2653 | 4600 lbs. | 1950kg |
| V2653XL | 4700 lbs. | 1996 kg |

B. RAMP METHOD

Ensure that the ramp is sufficiently strong to support the weight of the CONDOR®.

The ramp should be set, not steeper than this CONDOR®'s rated gradeability, which for Model V2648/53/XL is 14° or 25%, or a rise of 30 inches in a run of 10 feet.

Before driving the CONDOR® on a ramp, lower the platform completely, test the drive/steer controls and the brake system.

CAUTION
Select "low" drive speed, not "high" and not "creep".

The front of the CONDOR® should be uphill, meaning: Drive forward uphill and reverse down.

Keep CONDOR® in alignment with the ramp during loading and unloading procedures.

C. FORKLIFT LOADING AND UNLOADING METHOD

Ensure that the forklift has sufficient capacity to handle the weight of this CONDOR®. (SEE III. A.)

This CONDOR® can be lifted from the rear, using the forklift pockets provided.

NOTE THAT THE CENTER OF GRAVITY IS 50 INCHES FROM THE END OF THE CONDOR®.

The CONDOR® should only be raised to a height sufficient to clear any obstructions.

Keep forklift travel to a minimum, carry CONDOR® as close as possible to the ground, and set it down gently.