



SELF-PROPELLED
ELEVATING WORK PLATFORM

MODEL V1433XL, V1433

MODEL V1833XL, V1833

OPERATORS, MAINTENANCE,
PARTS MANUAL

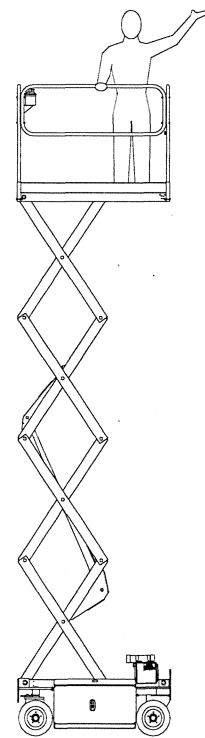
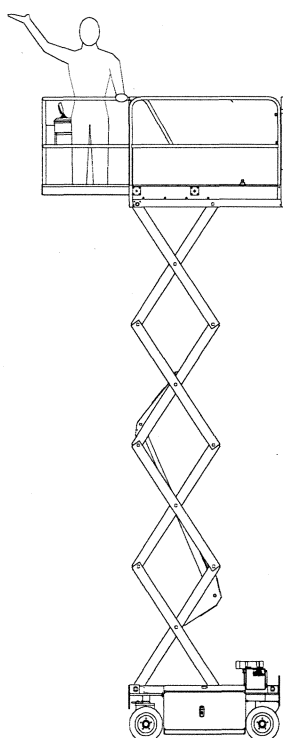

SHIPPING ADDRESS

CONDOR®

TIME CONDOR Corporation
8300 IMPERIAL DRIVE
WACO, TEXAS 76712
(254) 420-5200

MAILING ADDRESS

CONDOR®

TIME CONDOR Corporation
P.O. Box 21447
WACO, TEXAS 76702-1447
(254) 420-5200



SELF-PROPELLED
ELEVATING WORK PLATFORM

MODEL V1433XL, V1433

MODEL V1833XL, V1833

OPERATOR SECTION

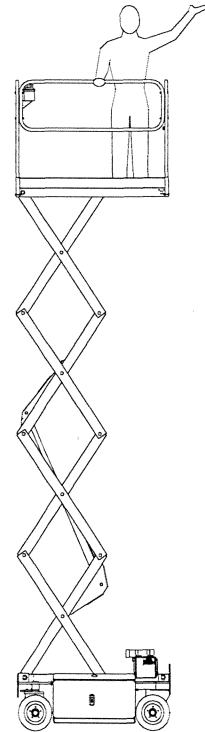
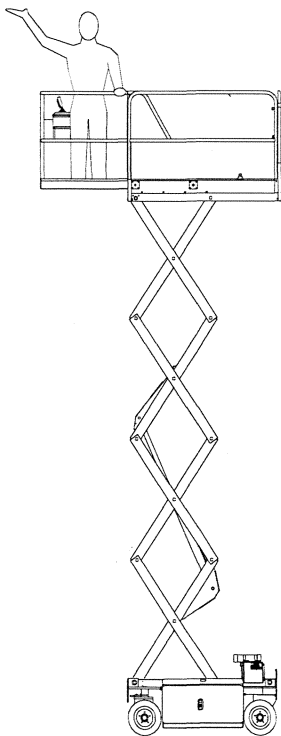

SHIPPING ADDRESS

CONDOR®

TIME CONDOR Corporation
8300 IMPERIAL DRIVE
WACO, TEXAS 76712
(254) 420-5200

MAILING ADDRESS

CONDOR®

TIME CONDOR Corporation
P.O. Box 21447
WACO, TEXAS 76702-1447
(254) 420-5200

INTRODUCTION

The primary purpose of this manual is to provide the user with a thorough understanding of the proper operating procedures necessary to comply with the intended use of the CONDOR®.

THIS MANUAL MUST BE RETAINED ON THE CONDOR® AT ALL TIMES.

Do not attempt to operate this CONDOR® until you have read and understood all information provided in this manual. Familiarize yourself with the functions and operations of the upper and lower controls. A good understanding of the controls, their limitations, and their capabilities will maximize operating efficiency. The various decals attached to this CONDOR® contain vital information. Read all decals before operating this CONDOR®.

It is YOUR RESPONSIBILITY to follow procedures while operating this CONDOR®. The manufacturer of this CONDOR® cannot control the wide range of applications that may be used in carrying out a variety of jobs. Therefore, IT IS THE USER'S RESPONSIBILITY to consider all of the personnel when making decisions regarding the intended use of this CONDOR®.

It is also YOUR RESPONSIBILITY to understand and obey all federal, state, and local regulations regarding the operation and use of aerial work platforms. A copy of the ANSI/SIA A92.6-1990 Manual of Responsibilities is attached for your use.

Condor Div. reserves the right to modify, improve, add, and/or delete certain design features of its products without any obligation to incorporate new features into products previously sold. Manuals are continually updated to reflect these changes.

DO NOT ALTER OR MODIFY THIS CONDOR® WITHOUT PRIOR WRITTEN APPROVAL FROM THE MANAGEMENT OF CONDOR Div.

SERVICE & MAINTENANCE

Many of the parts used in the manufacture of this CONDOR® have specific properties, and the manufacturer recommends that replacement parts be purchased through Condor Div. in order to ensure the original integrity of the product. Repairs and adjustments should only be made by trained and qualified personnel. Please refer to the maintenance and parts sections of the Condor Operation, Parts & Maintenance Manual for information on service and maintenance of this CONDOR®.



CONDOR® SERVICE INFORMATION

1. If you need assistance or have any service or maintenance questions, CONDOR® service and parts personnel are always available by phone or fax. The telephone numbers are:

(254) 420-5200 Telephone
(254) 420-5298 Voice Mail
(800) 443-5803 FAX

2. There are numerous written Maintenance Procedures available for this CONDOR®. These procedures are available through the CONDOR® Service Department to anyone who requests them.

3. Service and maintenance are not a substitute for trained, qualified service technicians. CONDOR® conducts service schools on a continuing basis. Call any of our service or sales persons for a schedule. Remember, training of mechanics is the responsibility of their employer, but CONDOR® Service Schools help you provide this training.

4. CONDOR® Service School Training Manuals are available for purchase through the parts department. The part numbers for these manuals are: #92333 for self-propelled models; and #92334 for truck-mounted models.

TABLE OF CONTENTS

INTRODUCTION i
SERVICE INFORMATION ii
TABLE OF CONTENTS iii

I. PREPARATION, INSPECTION, AND MAINTENANCE 1

- A. Overall Machine Condition 1
- B. Lower Control Station 1
- C. Emergency Lowering 1
- D. Platform and Upper Control Station 2
- E. Hydraulic System 2
- F. Batteries 2

II. MACHINE OPERATION 2

- A. Rated Work Load 2
- B. Lower Controls 2
- C. Upper Controls 3
- D. Emergency Lowering 3
- E. Lift-up Entry Gate 3
- F. Deck Extension 5
- G. Removable Upper Control Box 5

III. MOVING FROM JOB-SITE TO JOB-SITE 5

- A. Loading and Unloading 5
- B. Ramp Method 5
- C. Forklift Loading and Unloading Method 5
- D. Transporting 6
- E. Freewheel Operation 6

IV. STORAGE 6

APPENDIX: DECALS ILLUSTRATION 8

ANSI/SIA A92.6 - 1990 MANUAL OF RESPONSIBILITIES

IMPORTANT: A COPY OF THE ANSI/SIA A92.6 - 1990 MANUAL OF RESPONSIBILITIES IS ATTACHED TO THIS OPERATOR'S MANUAL. IT CONTAINS IMPORTANT OPERATING INFORMATION FOR THIS CONDOR®. READ IT BEFORE OPERATING THIS CONDOR®.

I. PREPARATION, INSPECTION, AND MAINTENANCE

The condition of this CONDOR® is very important, as it directly affects the operator as well as others. The operator must perform a thorough walk-around inspection each day prior to operating the CONDOR®. Any damage or faulty operation should be reported immediately. A **DO NOT OPERATE** tag outlining the problem should be attached to the lower control station and any discrepancies should be corrected before operating this CONDOR®.

KNOW THIS CONDOR® AND ITS CAPABILITIES. REPORT ANY UNUSUAL OPERATION, SUCH AS ERRATIC SWAY OR MOTION OF THE ARMS OR PLATFORM.

Some major areas to check daily are:

A. OVERALL MACHINE CONDITION

MISSING, BROKEN, OR DAMAGED PARTS:

- Check cylinder mounting pins, pivot pins, pin retainers, bearing pads, bolts, and nuts.

STRUCTURAL:

- Check for damaged or cracked welds on structural components-arms, platform, chassis.

TIRES AND WHEELS:

- Check for cracks, tears, cuts, or missing or loose lug nuts (a rust line running down the rim from the lug nut indicates a loose lug nut).

STEERING:

- Check steering link to knuckle connections and steering cylinder for proper and secure mounting.

BRAKES:

- Check for abnormal wear between deadbolts and hubs, and for loose or missing bolts, nuts, and pins.

DECALS:

- Check that all decals and warning signs are in place and are clearly legible.

CAUTION

Defective components, structural damage, missing parts, and equipment malfunction jeopardize the operator and other personnel and may cause excessive damage to the unit. A poorly maintained CONDOR® could become the greatest operational hazard you may encounter.

B. LOWER CONTROLS

- Check that all functions operate properly, that switches return freely to neutral position. Do not operate the CONDOR® with sticking controls

C. EMERGENCY LOWERING

- Check emergency lowering function by pulling red T-handle.

D. PLATFORM AND UPPER CONTROL STATION

- Check that lift-up entry gate is functional and that chain is secure.
- Re-check the structural condition of the platform—pins, railings, and floor.
- Check for missing bolts & nuts - Replace before operating.
- Check that extension deck is locked in place.
- Check function of red button. It disconnects power to the controls and, when pushed, stops all powered functions.
- Check that drive control lever returns freely to neutral.

E. HYDRAULIC SYSTEM

- Check the hydraulic tank fluid level with the platform all the way down. Fluid must be visible in sight glass. Add Shell Tellus T-32 Hydraulic Fluid if required. Ensure that the breather cap is clean and in place on the tank.
- Check for hydraulic leaks at all fittings and valves.
- Check all hydraulic hoses and tubes for damage and kinks.

F. BATTERIES

CAUTION
Keep flame, sparks and metal away from the batteries.

- Check Electrolyte level daily in each cell. If necessary, add clear, odorless, mineral free water to bring the level to 1/2" above the top of the separators, or to the Level Indicator (if equipped), in each cell. Only add water after charging cycle is complete.

- Keep battery tops clean and dry.
- Keep vent caps tightly in place.
- Check that battery cable connections are tight and clean and free of corrosion.
- Make sure the battery charger and the indicator lights and meter are not damaged.

II. CONDOR® OPERATION

CAUTION
CONDOR® MUST BE OPERATED ON FIRM, LEVEL GROUND ONLY.

A. RATED WORK LOAD

The platform will support a combined weight equal to the unit's rated work load—including personnel, tools, and equipment—throughout the working envelope of the CONDOR®.

Rated work load, on extension deck only, is not to exceed 250 lbs. (113 kg) including one occupant. Total rated work load is not to exceed 600 lbs. for the V1433, 500 lbs. for the V1833.

B. LOWER CONTROLS

CAUTION
ARM STAND MUST BE USED WHEN MAINTENANCE PERFORMED ON CONDOR® REQUIRES SCISSOR ARM'S TO BE RAISED.

1. To engage arm stand, raise platform, then rotate stand until it hangs vertically. Lower the platform until the arm stand rests on the cross tube on the frame. Maintenance can now begin.

2. To store arm stand, raise platform so that arm stand can be rotated until it rests on the stop provided on the scissor arms.

Turn "controls" switch to "lower" position, to operate from ground.

In an emergency, push red button. To operate, button must be pulled out. (Also, if applicable, battery disconnect switch must be "on" to operate.)

Push "raise" or "lower" switches to move platform.

Turn switch to "upper" position, to operate from platform.

C. UPPER CONTROLS

Turn "controls" switch, on lower control panel, to "upper" position to operate from platform.

NOTE:

Chain should be snapped in place across entry. Gate should be lowered and closed when operating **CONDOR®** from upper controls.

In an emergency, push red button. To operate from platform, both red buttons, on lower and upper controls, must be pulled out.

To raise and lower platform, push and hold the green "power" button, and push the "raise" or "lower" button. Release buttons to stop movement.

Select desired drive speed with the "high/low/creep" switch. (A limit switch automatically cuts drive speed to "creep" as the platform is raised.)

"XL" MODELS:

To drive forward or reverse, squeeze lever switch on handle, and push or pull handle in the intended direction of travel. Release lever switch to stop movement. Letting go of handle also will stop movement.

NON "XL" MODELS:

To drive forward or reverse, depress foot switch, and engage "Forward/Reverse" toggle switch in the intended direction of travel.

Brakes are automatically released whenever the drive handle is moved. Let go of the handle to automatically set the brakes.

To steer left or right, squeeze lever switch on handle, and depress rocker switches on top of handle in the intended direction of travel. Steering is not automatically self-centering. Be sure the steering wheels point in the direction you want before letting go of the steer switch.

D. EMERGENCY LOWERING

For emergency lowering, grasp the Tee-handle located below the rear bumper. Gently pull to lower the platform. Release handle to stop lowering.

E. LIFT-UP ENTRY GATE

To load 4' wide sheets, lift entry gate up until lockpins snap in place. After loading, pull at both lockpins, to let gate fall into place. Keep gate down, except for loading and unloading.

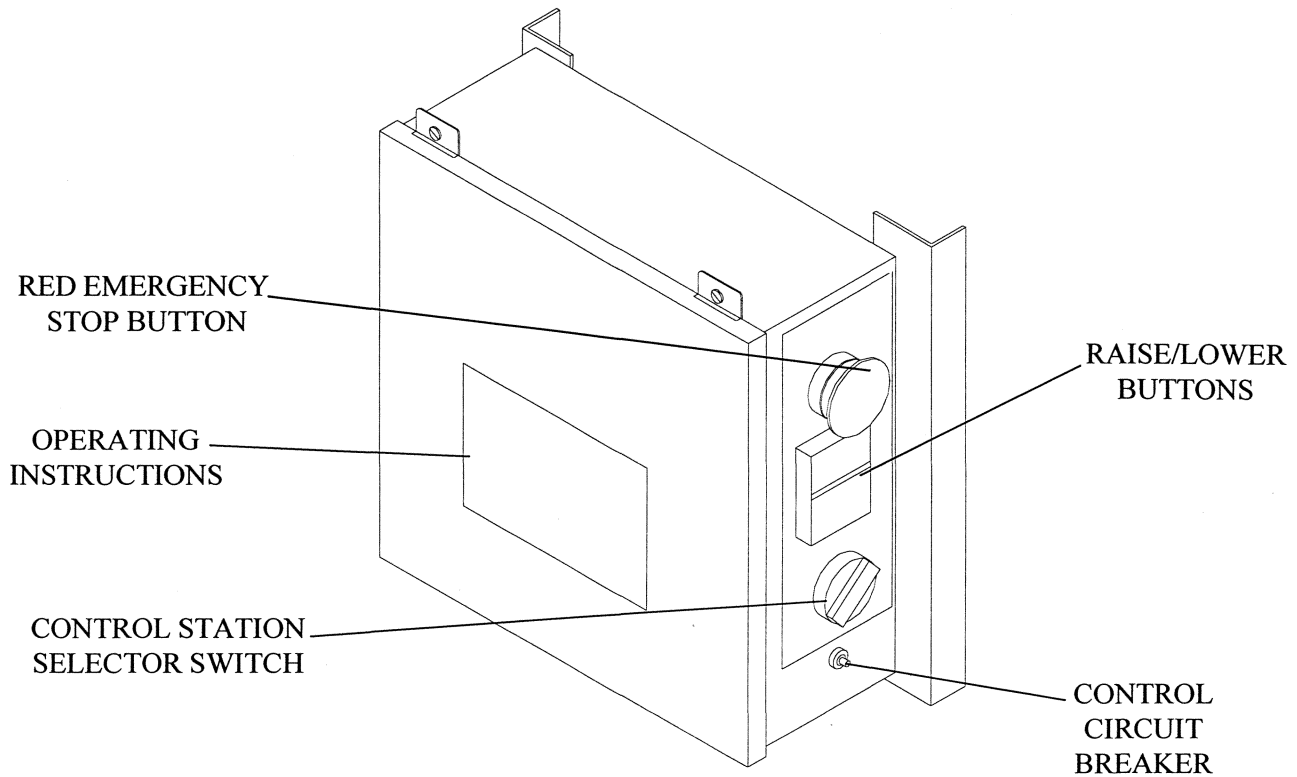
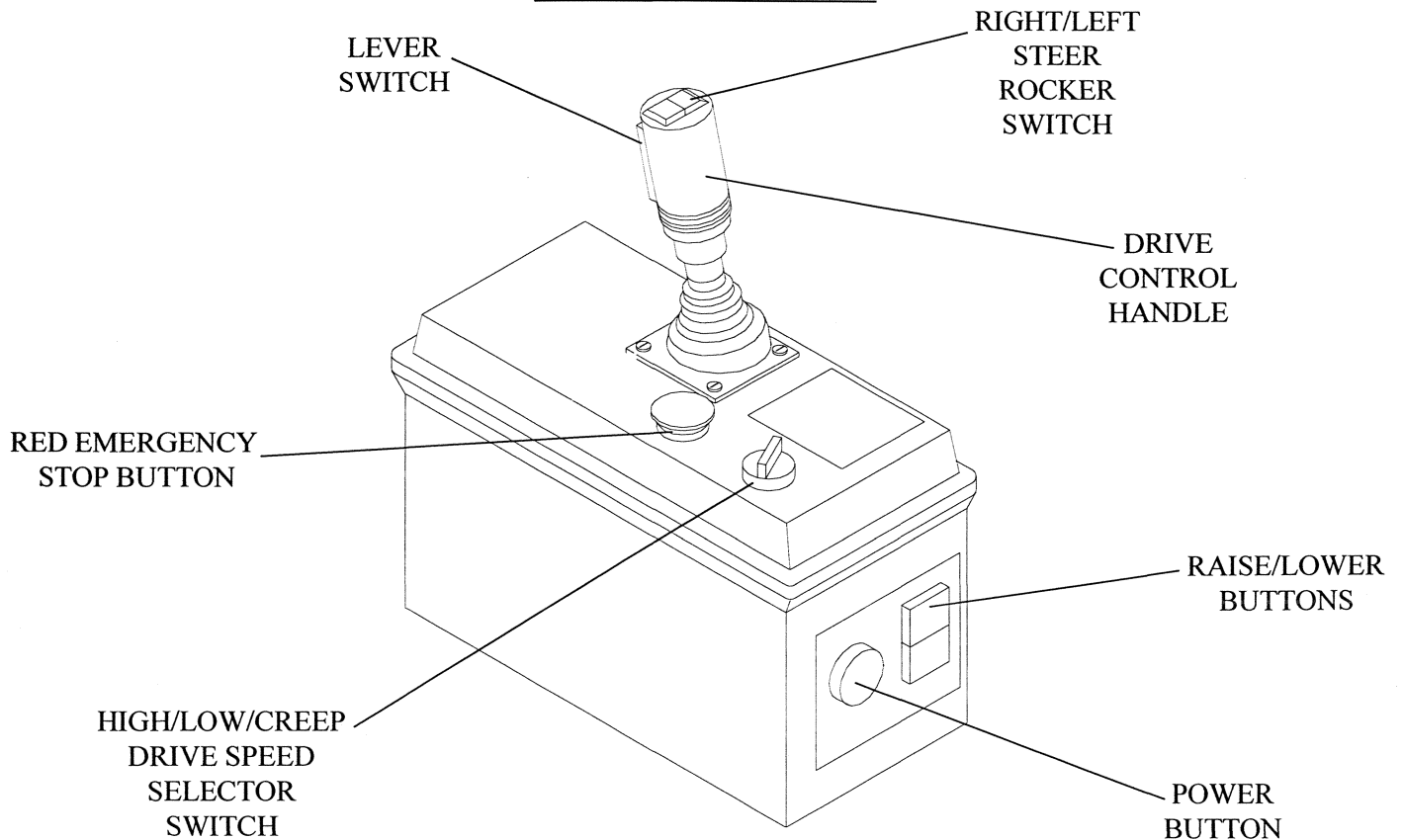
LOWER CONTROLS**UPPER CONTROLS**

F. DECK EXTENSION

Lift lockpin, at right side of deck, and push extension deck forward (or out). When fully extended, lockpin will automatically lock. To retract, lift lockpin and pull extension deck all the way back until lockpin automatically locks extension deck in place.

CAUTION
Do not lower extension deck onto people or any objects!

G. 'REMOVABLE' UPPER CONTROL BOX

Unsnap overcenter latch at bottom of upper control box and pull plug out of receptacle. Bend cable so that plug faces down. Snap cover onto receptacle at bottom of box. Lift box and store it in a secure place to prevent unauthorized use of the CONDOR®.

III. MOVING FROM JOB-SITE TO JOB-SITE

A. LOADING AND UNLOADING

Although this CONDOR® is somewhat small compared with larger construction equipment, it requires the same care and attention in loading, transporting, and unloading. At no time should its size, or weight be under estimated. Before loading or unloading, inspect the CONDOR® for any physical damage or defects.

The means by which you load or unload the CONDOR® should be of sufficient strength to withstand its weight.

MODEL	WEIGHT(#)	WEIGHT(KG)
V1433/XL	2,200 lbs.	998 kg
V1833/XL	2,400 lbs.	1089 kg

B. RAMP METHOD

Ensure that the ramp is sufficiently strong to support the weight of the CONDOR®.

The ramp should be set, not steeper than this CONDOR®'s rated gradeability, which for Model V1433/XL, V1833/XL is 14° or 25%, or a rise of 30 inches in a run of 10 feet.

Before driving the CONDOR® on a ramp, lower the platform completely, test the drive/steer controls and the brake system.

CAUTION
Select "low" drive speed, not "high" and not "creep".

The front of the CONDOR® should be uphill, meaning: Drive forward uphill and reverse down.

Keep CONDOR® in alignment with the ramp during loading and unloading procedures.

C. FORKLIFT LOADING AND UNLOADING METHOD

Ensure that the forklift has sufficient capacity to handle the weight of this CONDOR®.

This CONDOR® can be lifted from the rear, using the forklift pockets provided.

NOTE THAT THE CENTER OF GRAVITY IS 50 INCHES FROM THE END OF THE CONDOR®.

The CONDOR® should only be raised to a height sufficient to clear any obstructions.

Keep forklift travel to a minimum, carry CONDOR® as close as possible to the ground, and set it down gently.

D. TRANSPORTING

This **CONDOR®** can be easily transported between job-sites if the following rules and procedures are followed:

Block all wheels to prevent forward and reverse motion.

Tie down the **CONDOR®** with chains or cables, running them through the tie-down holes only. Do not tie down over the guardrails or entry steps.

Always turn the power off at the lower control station.

E. FREEWHEEL OPERATION

CAUTION

This **CONDOR®** must be on firm, level ground when releasing the parking brakes. To put the **CONDOR®** into freewheel mode, use the brake release handles on the rear axle. One handle is on the front side of the axle and the other is on the rear side of the axle. Turn each release handle 90° and at the same time, slightly rotate it. The brakes are now released. (Released brakes will automatically reset the next time forward or reverse drive is used, then will engage when drive is stopped.)

Never exceed 5 mph when moving the **CONDOR®** in the freewheel mode.

IV. STORAGE

When you get out of the platform, leave it all the way down.

CAUTION

Never park the **CONDOR® with platform raised.**

NOTES

APPENDIX: DECALS ILLUSTRATION

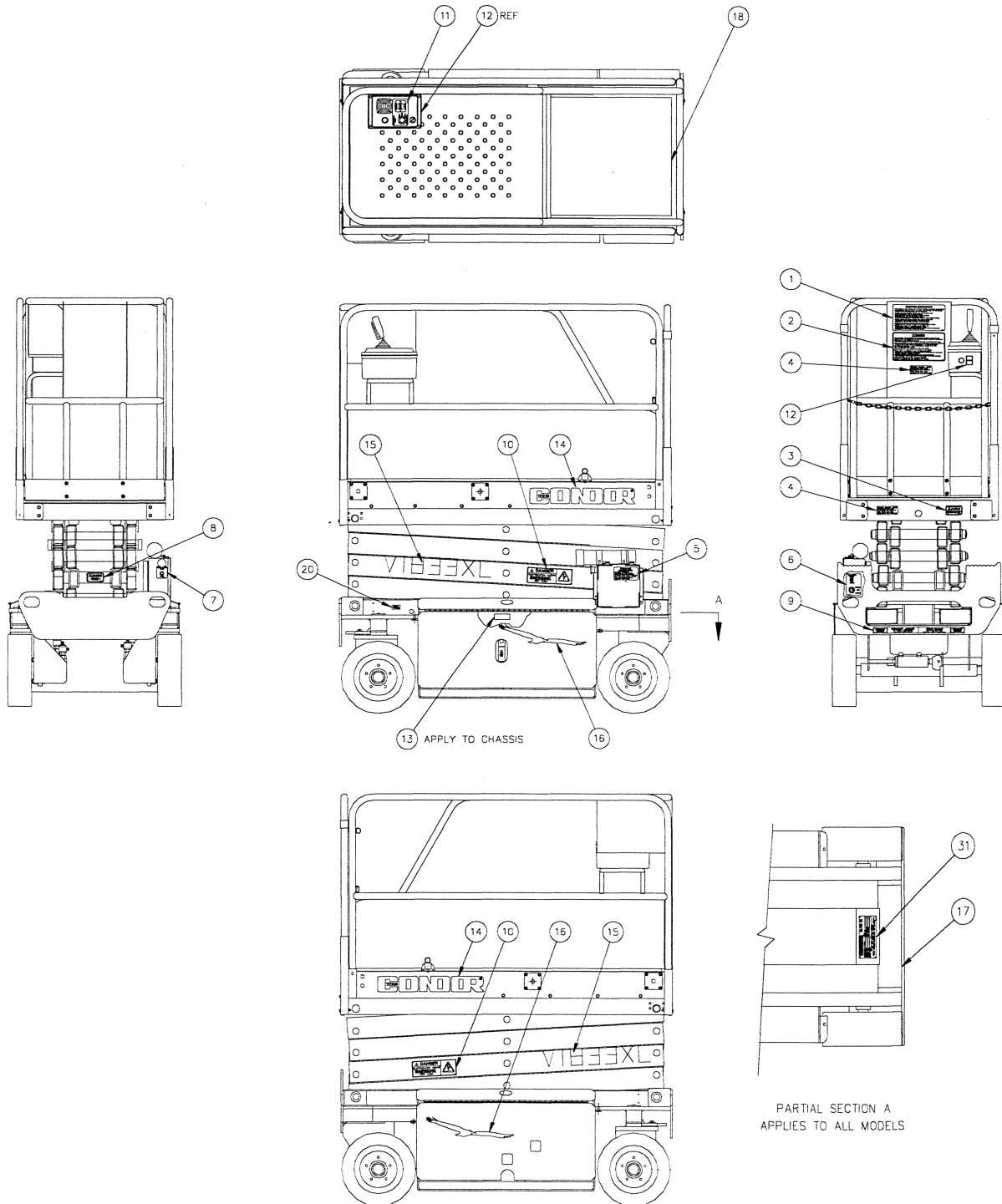

NOTES:

MODEL V1833XL IS ILLUSTRATED, OTHER MODELS ARE SIMILAR.

APPENDIX: DECALS ILLUSTRATION

ITEM	PART NUMBER	DESCRIPTION	QTY
Ref	*55892-104	Decal Kit, V1833XL Essential	Ref.
	*55892-103	Decal Kit, V1833 Essential	Ref.
	*55892-102	Decal Kit, V1433XL	Ref.
	*55892-101	Decal Kit, V1433	Ref.
*1	55890	Decal, V Upper Operator Instructions	1
	55889	Decal, V XL Upper Operator Instructions	1
*2	55894	Decal, V General Caution	1
*3	54652-003	Decal, Guardrail/Chain Caution	1
*4	55944-600	Decal, 250/600 Rated Load V1433/XL	2
	55944-500	Decal, 250/500 Rated Load V1833/XL	2
*5	55877-003	Decal, V14/18 Lower Operating Instructions	1
*6	55877-001	Decal, V14/18 Lower Controls	1
*7	55877-002	Decal, V14/18 Stop/Fuse	1
*8	54652-002	Decal, Arm Strand Caution	1
*9	54984-005	Decal, Rear Bumper	1
*10	55882	Decal, Electrocutation Hazard	2
*11	55871-001	Decal, V14/18 Upper Electrical Box Top	1
	55856-001	Decal, V XL Upper Control Box Top	1
*12	55871-002	Decal, V14/18 Upper Electrical Box Front	1
	55856-002	Decal, V XL Upper Control Box	1
13	54984-007	Decal, Hydraulic Fluid	1
14	55940-023	Decal, CONDOR 3.45 x 23	2
15	55935	Decal, V1433XL	2
	55936	Decal, V1833XL	2
16	55941-017	Decal, Condor Bird	2
17	53259	Tape, Non-Skid Jet Black	1.50LF
18	66921	Coating, Non-Skid Jet Black	.25GL
19	55892-DWG	Dwg. V1418 Decal Installation	1
20	54984-006	Decal, 110 Volt Extention To Platform V14/18XL	1
31	51340	Namplate Scissors Identification	Ref.

- Indicates Items Not Shown

*Indicates Included In Essential Decals

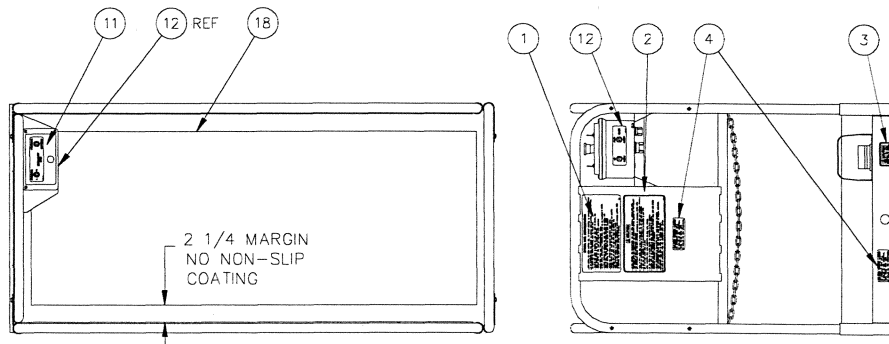

PLANVIEW OF
MODELS V1433 & V1833

PARTIAL REAR VIEW OF
MODELS V1433 & V1833

APPENDIX: DECALS ILLUSTRATION

1

OPERATING INSTRUCTIONS

- TURN SWITCH, ON LOWER CONTROL BOX, TO "UPPER" POSITION, TO OPERATE FROM PLATFORM.
- IN AN EMERGENCY, PUSH RED BUTTON. TO OPERATE FROM PLATFORM, BOTH RED BUTTONS, ON LOWER AND ON UPPER CONTROLS, MUST BE PULLED OUT.
- TO RAISE AND LOWER PLATFORM, PUSH AND HOLD THE GREEN "ENABLE" BUTTON, AND PUSH THE "UP" OR "DOWN" BUTTON.
RELEASE BUTTONS TO STOP MOVEMENT.
- SELECT DRIVE SPEED WITH "FAST/SLOW/CREEP" SWITCH.
A LIMIT SWITCH AUTOMATICALLY REDUCES DRIVE SPEED AS THE PLATFORM IS RAISED.
- TO DRIVE FORWARD OR REVERSE, SQUEEZE GRIP SWITCH ON HANDLE, AND PUSH OR PULL HANDLE IN INTENDED DIRECTION OF TRAVEL.
RELEASE LEVER SWITCH OR LET GO OF HANDLE TO STOP MOVEMENT.
- BRAKES ARE AUTOMATICALLY RELEASED WHENEVER DRIVE MOVES.
RELEASE GRIP SWITCH OR LET GO OF HANDLE TO AUTOMATICALLY SET BRAKES.
- TO STEER LEFT OR RIGHT, SQUEEZE GRIP SWITCH ON HANDLE, AND DEPRESS ROCKER SWITCHES ON TOP OF HANDLE IN INTENDED DIRECTION OF TRAVEL.
STEERING IS NOT AUTOMATICALLY SELF-CENTERING. BE SURE STEERING WHEELS POINT IN DIRECTION YOU WANT BEFORE LETTING GO OF SWITCHES.

55890

OPERATING INSTRUCTIONS

- TURN SWITCH, ON LOWER CONTROL BOX, TO "UPPER" POSITION, TO OPERATE FROM PLATFORM.
- IN AN EMERGENCY, PUSH RED BUTTON. TO OPERATE FROM PLATFORM, BOTH RED BUTTONS, ON LOWER AND ON UPPER CONTROLS, MUST BE PULLED OUT.
- TO RAISE AND LOWER PLATFORM, PUT AND KEEP FOOT ON SWITCH, AND PUSH TOGGLE SWITCH IN "UP" OR "DOWN" DIRECTION.
RELEASE SWITCH OR TAKE FOOT OFF SWITCH TO STOP MOVEMENT.
- SELECT DRIVE SPEED WITH "FAST/SLOW/CREEP" SWITCH.
A LIMIT SWITCH AUTOMATICALLY REDUCES DRIVE SPEED AS THE PLATFORM IS RAISED.
- TO DRIVE FORWARD OR REVERSE, PUT AND KEEP FOOT ON SWITCH, AND PUSH OR PULL TOGGLE SWITCH IN INTENDED DIRECTION OF TRAVEL.
RELEASE SWITCH, OR TAKE FOOT OFF SWITCH TO STOP MOVEMENT.
- BRAKES ARE AUTOMATICALLY RELEASED WHENEVER DRIVE MOVES.
RELEASE SWITCH OR TAKE FOOT OFF SWITCH TO AUTOMATICALLY SET BRAKES.
- TO STEER LEFT OR RIGHT, PUT AND KEEP FOOT ON SWITCH, AND MOVE "STEERING" SWITCH IN INTENDED DIRECTION OF TRAVEL.
STEERING IS NOT AUTOMATICALLY SELF-CENTERING. BE SURE STEERING WHEELS POINT IN DIRECTION YOU WANT BEFORE LETTING GO OF SWITCH.

55890

2

 CAUTION

- DO NOT OPERATE THIS CONDOR[®] UNTIL YOU HAVE BEEN PROPERLY TRAINED AND HAVE COMPLETELY READ AND UNDERSTOOD THE OPERATOR'S MANUAL LOCATED ON THIS CONDOR[®].
- THIS CONDOR[®] IS NOT ELECTRICALLY INSULATED.
SEE OPERATOR'S MANUAL FOR SAFE APPROACH DISTANCES TO ENERGIZED POWER LINES.
- PRIOR TO EACH DAY'S USE, CHECK TO MAKE SURE ALL FUNCTIONS ARE OPERATING PROPERLY. PERFORM ALL INSPECTIONS REQUIRED BY SECTION 6 OF THE ANSI 92.6 STANDARD.
- DO NOT USE THE CONDOR[®], IF IT IS MALFUNCTIONING OR DAMAGED IN ANY WAY, OR IF THE WIND BLOWS OVER 15 MPH.
- RAISE PLATFORM ONLY WHEN CONDOR[®] IS ON FIRM, LEVEL GROUND.
- DO NOT DRIVE ON A SLOPE UNLESS THE PLATFORM IS FULLY LOWERED.
- ALWAYS LOOK IN THE DIRECTION IN WHICH THE PLATFORM IS MOVING.
WATCH FOR, AND AVOID, OVERHEAD OBSTRUCTIONS AND ANYTHING ELSE THAT MAY STRIKE PLATFORM, PERSONNEL, CONTROLS, OR CONDOR[®].
- FOLLOW INSTRUCTIONS IN OPERATOR'S MANUAL WHEN SERVICING BATTERIES.
EACH REPLACEMENT BATTERY MUST WEIGH AT LEAST AS MUCH AS ORIGINAL EQUIPMENT.
- REPLACEMENT TIRES MUST BE SAME AS ORIGINAL EQUIPMENT.
- IN CASE OF EMERGENCY, PUSH RED "EMERGENCY STOP" BUTTON.

55894

APPENDIX: DECALS ILLUSTRATION

3



4

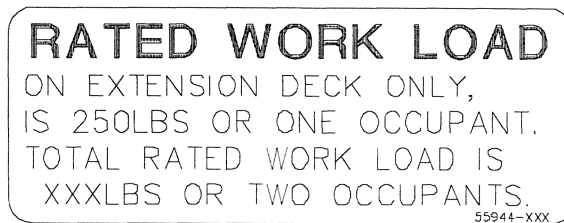

5

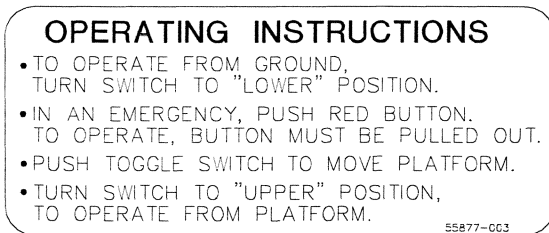

6

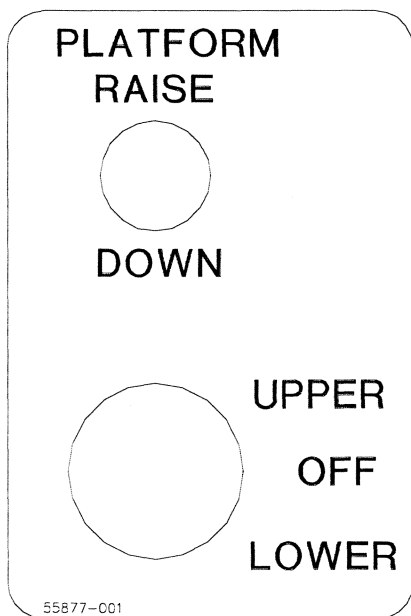

7

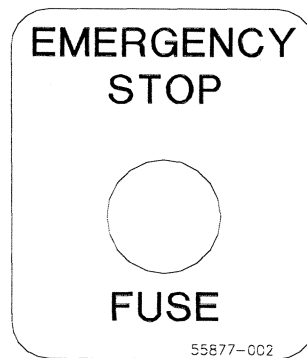

APPENDIX: DECALS ILLUSTRATION

8

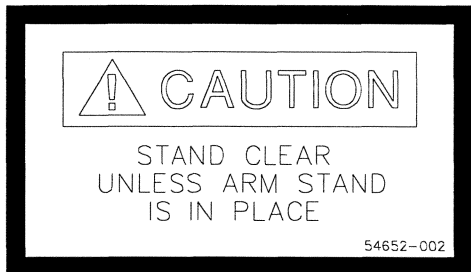

9

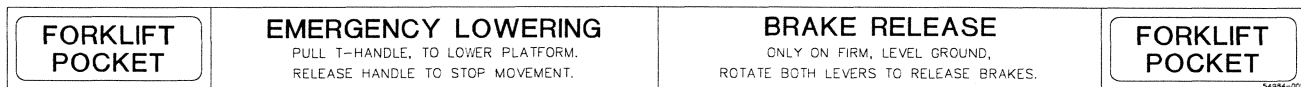

10

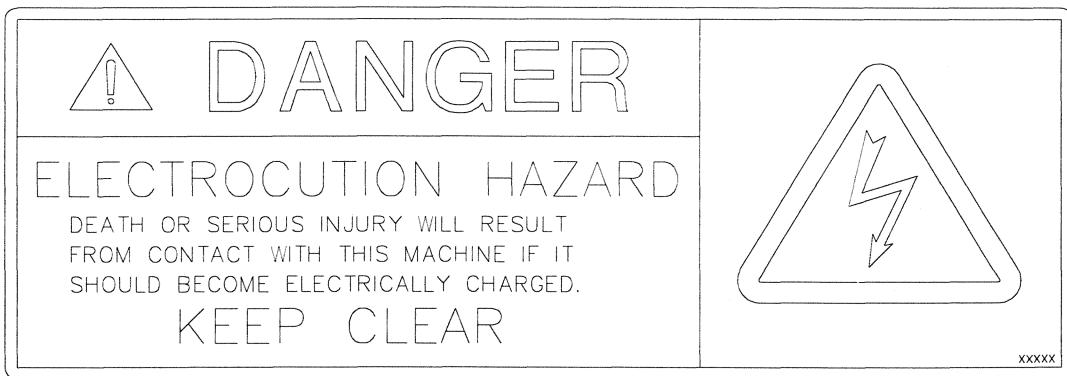

13

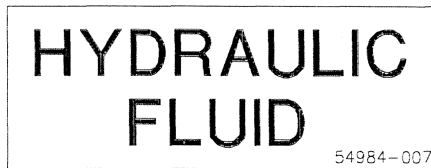

APPENDIX: DECALS ILLUSTRATION

20

<p>110 VOLT EXTENSION TO PLATFORM</p> <p>54984-006</p>
--

31

		8300 IMPERIAL DRIVE WACO, TEXAS 76712	
CALAVAR CORPORATION			
MANUFACTURED IN U.S.A.	SERIAL NO.		
CONDOR MODEL	RATED WORK LOAD 750#		
PLATFORM HEIGHT 20'-0"	HYD. PRESSURE 2,700 PSI		
SYSTEM VOLTAGE 24 V. DC			
<p>THIS UNIT IS NOT ELECTRICALLY INSULATED. THIS SELF-PROPELLED ELEVATING WORK PLATFORM CONFORMS TO ALL APPLICABLE REQUIREMENTS OF ANSI A92.6-1990</p>			
51340			



SELF-PROPELLED
ELEVATING WORK PLATFORM

MODEL V1433XL, V1433

MODEL V1833XL, V1833

MAINTENANCE SECTION

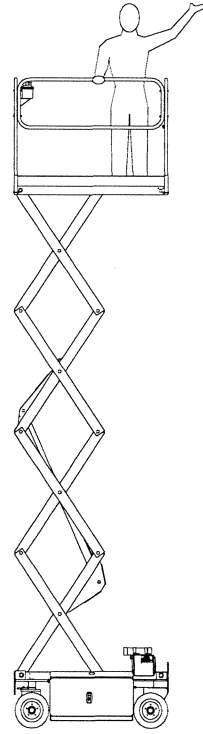
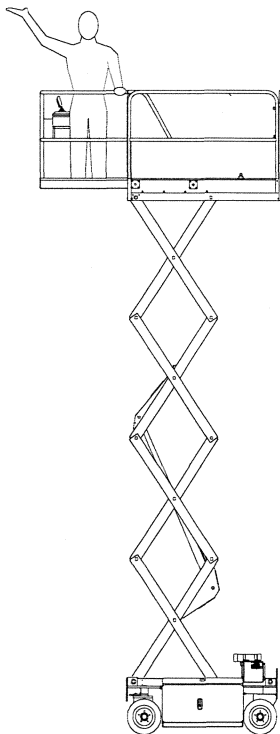

SHIPPING ADDRESS

CONDOR®

TIME CONDOR Corporation
8300 IMPERIAL DRIVE
WACO, TEXAS 76712
(254) 420-5200

MAILING ADDRESS

CONDOR®

TIME CONDOR Corporation
P.O. Box 21447
WACO, TEXAS 76702-1447
(254) 420-5200

INTRODUCTION

The primary purpose of this manual is to provide the user with a thorough understanding of the proper operating procedures necessary to comply with the intended use of the CONDOR®, and to provide the information necessary to maintain and service the CONDOR®.

THE OPERATOR'S MANUAL MUST BE RETAINED ON THE CONDOR® AT ALL TIMES.

Do not attempt to operate or service the CONDOR® until you have read and understood all information provided in this manual. Familiarize yourself with the functions and operations of the upper and lower controls. A good understanding of the controls, their limitations, and their capabilities will maximize operating efficiency. The various decals attached to this CONDOR® also contain vital operational instructions. Read the decals before operating this CONDOR®.

It is YOUR RESPONSIBILITY to follow procedures while operating the CONDOR®.

The manufacturer of this CONDOR® cannot control the wide range of applications that may be used in carrying out a variety of jobs. Therefore, it is THE USER'S RESPONSIBILITY to consider all personnel when making decisions regarding the CONDOR®'s intended use.

It is also YOUR RESPONSIBILITY to understand and obey all federal, state, and local regulations regarding the operation and use of aerial work platforms. A copy of the ANSI/SIA Manual of Responsibilities is attached for your use: ANSI/SIA A92.5-1992 is provided for Boom-Supported Elevating Work Platforms, and ANSI/SIA A92.6-1990 is provided for Self-Propelled Elevating Work Platforms.

TIME CONDOR Corporation reserves the right to modify, improve, add, and/or delete certain design features of its products without any obligation to incorporate new features into products previously sold. Our manuals are continually updated to reflect these changes.

***DO NOT ALTER OR MODIFY THIS CONDOR® WITHOUT PRIOR WRITTEN APPROVAL
FROM THE MANAGEMENT OF TIME CONDOR CORPORATION***

SERVICE & MAINTENANCE

Many of the parts used in the manufacture of the CONDOR® have specific properties, and the manufacturer recommends that replacement parts be purchased through TIME CONDOR Corporation in order to ensure the original integrity of the product. Repairs and adjustments should only be made by trained and qualified personnel. Please refer to the maintenance and parts sections of the TIME CONDOR Operation, Maintenance, & Parts Manual for information on service and maintenance of the CONDOR®.

NOTE: Please refer to the TIME CONDOR section of the Operation, Maintenance, & Parts Manual for information pertaining to your CONDOR®.