

# EPG20-30 ECG20-32 ECG20-30X

---

## SERVICE MANUAL

RATED CAPACITY : 2000 – 3200 kg

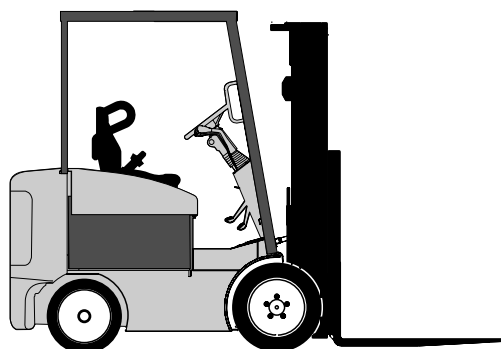

Part No. 8027886

Book No. SM-677

Rev. 2

---

Manufactured by

**CLARK** Material Handling  
Asia

Copyrighted Material  
Intended for CLARK dealers only  
Do not sell or distribute

#40-1, Ungnam-Dong,  
Changwon-City, Kyungnam,  
Korea

## Truck Models Covered by this Manual

This manual consists of a “base” module that pertains to ECG 20-32, EPG 20-30 models and other modules that pertain only to specific models. Manuals shipped with the truck contain the base module and the module specific to the purchased truck.

You may, however, purchase specific modules and expand your manual to fully cover multiple models. To do so, order the desired modules as you would any other Clark part.

## Arrangement and Use of this Manual

Clark arranges parts and service procedures by standardized *Groups*. In this manual, Groups are similar to “chapters”. Groups are listed in the indexes on the next page.

Each Group begins with a table of contents that shows the *Sections* contained within the Group. Lengthy Sections also begin with a table of contents.

Each Group and Section has an identifying name and number, or “ID”.

Each page also has a unique ID. The page ID consists of three numbers separated by hyphens. The three numbers represent the Group number, the Section number, and the page number. For example, “00-1-2” on the lower corner of the page indicates Group 00, Section 1, page 2.

The Group number sometimes has a letter added to it in parentheses if one or more variations of the Group exist. For example, if the truck has a standard transaxle, Group 06 is expressed as “06(S)”; if the truck has a hydrostatic transmission, Group 06 is expressed as “06(H)”.

You can quickly locate a specific point in the manual by using the headers and footers that appear on every Section page. The following illustration points out these areas.

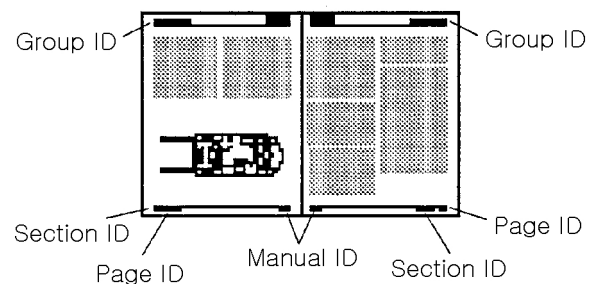

### IMPORTANT

**This manual is intended for the use of trained service personnel. Please read Group SA, “Safe Maintenance”, and the *Operator’s Manual* before working on or operating the truck.**

Nov. 2003

When new or revised information is published to update this manual the action to be taken with the pages is indicated in the table.

Pages not marked are not currently revised, but are included for page numbering continuity.

Mark	Indication	Action required
○	Page to be newly added	Add
●	Page to be replaced	Replace
( )	Page to be deleted	Discard

Mark	Page	Revision number	Mark	Page	Revision number	Mark	Page	Revision number	Mark	Page	Revision number
	SA-1-1			12-1-3			16-3-3			17-2-3	
	SA-1-2			12-1-4	①	●	16-3-4	①		17-2-4	
	SA-1-3			12-1-5	①		16-3-5			17-2-5	
	SA-1-4			12-1-6			16-3-6			17-2-6	
	SA-1-5			12-2-1			16-3-7			17-2-7	
	SA-2-1			12-2-2			16-3-8	①		17-2-8	
	SA-2-2						16-3-9			17-2-9	
	SA-2-3	①		13-1-1			16-3-10			17-2-10	
	SA-2-4	①		13-1-2			16-4-1			17-2-11	
	SA-2-5	①	●	13-1-3	①		16-4-2			17-2-12	
	SA-3-1			13-1-4			16-4-3			17-2-13	
	SA-3-2			13-2-1			16-4-4			17-2-14	①
	SA-3-3			13-2-2			16-4-5			17-2-15	①
			●	13-2-3	①	●	16-4-6	①			
	PS-1-1	①		13-3-1			16-4-7			19-1-1	
	PS-1-2			13-3-2			16-4-8			19-1-2	
●	PS-1-3	②		13-3-3			16-4-9			19-1-3	
○	PS-1-3-1			13-4-1			16-4-10			19-1-4	
	PS-1-4			13-4-2			16-4-11	①		19-1-5	
	PS-1-5			13-4-3	①		16-4-12			19-1-6	
	PS-2-1								●	19-2-1	①
	PS-2-2	①		16-1-1		●	17-1-1	②		19-2-2	
	PS-2-3	①		16-1-2			17-1-2	①		19-2-3	
	PS-2-4	①		16-1-3			17-1-3			19-2-4	
	PS-2-5			16-1-4	①		17-1-4	①		19-2-5	
●	PS-2-6	②		16-1-5			17-1-5			19-2-6	①
	PS-2-7	①		16-1-6		●	17-1-6	②		19-2-7	
	PS-2-8			16-1-7			17-1-7			19-2-8	①
	PS-2-9	①		16-2-1		●	17-1-8	②		19-2-9	①
	PS-2-10	①		16-2-2			17-1-9			19-2-10	①
	PS-2-11			16-2-3			17-1-10			19-2-11	
	PS-2-12			16-2-4			17-1-11			19-2-12	①
	PS-2-13			16-2-5		●	17-1-12	①		19-2-13	
	PS-2-14	①		16-2-6			17-1-13			19-2-14	
	PS-3-1			16-2-7		○	17-1-14			19-2-15	
	PS-3-2			16-2-8		○	17-1-15			19-2-16	
				16-2-9		○	17-1-16			19-2-17	
	12-1-1			16-3-1			17-2-1			19-2-18	
●	12-1-2	①		16-3-2			17-2-2			19-2-19	

# REVISION HISTORY

# CLARK

Mark	Page	Revision number	Mark	Page	Revision number	Mark	Page	Revision number	Mark	Page	Revision number
	19-2-20			19-5-10			19-6-22		○	19-8-1	
	19-2-21			19-5-11			19-6-23		○	19-8-2	
	19-2-22			19-5-12			19-6-24		○	19-8-3	
	19-2-23			19-5-13			19-6-25		○	19-8-4	
	19-2-24			19-5-14			19-6-26		○	19-8-5	
	19-2-25			19-5-15			19-6-27		○	19-8-6	
	19-2-26	①		19-5-16			19-6-28		○	19-8-7	
	19-2-27			19-5-17			19-6-29		○	19-8-8	
	19-2-28	①		19-5-18			19-6-30		○	19-8-9	
	19-2-29			19-5-19			19-6-31		○	19-8-10	
	19-2-30			19-5-20			19-6-32		○	19-8-11	
	19-2-31		●	19-5-21	①		19-6-33		○	19-8-12	
	19-2-32		○	19-5-22			19-7-1	○	○	19-8-13	
	19-2-33			19-5-23			19-7-2	○	○	19-8-14	
	19-3-1			19-5-24			19-7-3	○	○	19-8-15	
	19-3-2	①		19-5-25			19-7-4	○	○	19-8-16	
	19-3-3			19-5-26			19-7-5	○	○	19-8-17	
	19-3-4			19-5-27			19-7-6	○	○	19-8-18	
	19-3-5			19-5-28			19-7-7	○	○	19-8-19	
	19-3-6			19-5-29			19-7-8	○	○	19-8-20	
	19-3-7			19-5-30			19-7-9	○	○	19-8-21	
	19-3-8			19-5-31			19-7-10	○	○	19-8-22	
	19-3-9	①		19-5-32			19-7-11	○	○	19-8-23	
	19-4-1	①	○	19-5-33			19-7-12	○	○	19-8-24	
●	19-4-2	①	●	19-6-1	①		19-7-13	○	○	19-8-25	
●	19-4-2-1	①		19-6-2			19-7-14	○	○	19-8-26	
●	19-4-3	①		19-6-3			19-7-15	○	○	19-8-27	
●	19-4-4	②		19-6-4			19-7-16	○	○	19-8-28	
	19-4-5			19-6-5			19-7-17	○	○	19-8-29	
	19-4-6	①		19-6-6			19-7-18	○	○	19-8-30	
	19-4-7	①		19-6-7			19-7-19	○	○	19-8-31	
	19-4-8	①		19-6-8			19-7-20	○	○	19-8-32	
●	19-4-9	①		19-6-9			19-7-21	○	○	19-8-33	
●	19-4-10	①		19-6-10			19-7-22	○			
○	19-4-11			19-6-11			19-7-23	○		20-1-1	
○	19-4-12			19-6-12			19-7-24	○		20-1-2	①
	19-5-1			19-6-13			19-7-25	○		20-1-3	①
	19-5-2			19-6-14			19-7-26	○		20-2-1	
	19-5-3			19-6-15			19-7-27	○	●	20-2-2	①
	19-5-4			19-6-16			19-7-28	○		20-3-1	
	19-5-5			19-6-17			19-7-29	○		20-3-2	①
	19-5-6			19-6-18			19-7-30	○	●	20-4-1	①
	19-5-7			19-6-19			19-7-31	○		20-4-2	①
	19-5-8			19-6-20			19-7-32	○	●	20-4-3	②
	19-5-9			19-6-21			19-7-33	○		20-4-4	①

Mark	Page	Revision number	Mark	Page	Revision number	Mark	Page	Revision number	Mark	Page	Revision number
●	20-4-5	②		23-5-4	①	○	25-5-18	①		29-4-3	
	20-4-6	①		23-5-5	①					29-4-4	
●	20-4-7	①		23-5-6			26-1-1	①		29-4-5	
●	20-4-8	②		23-5-7			26-1-2	①			
	20-4-9			23-5-8		●	26-1-3	①	●	30-1-1	②
	20-4-10			23-6-1			26-2-1			30-1-2	
	20-4-11	①	●	23-6-2	①		26-2-2	①	●	30-2-1	①
●	20-4-12	①		23-6-3			26-2-3		○	30-2-2	
●	20-4-13	②		23-6-4			26-2-4		○	30-2-3	
●	20-4-14	②	●	23-6-5	①		26-3-1			30-3-1	
	20-5-1	①		23-6-6			26-3-2			30-3-2	
	20-5-2			23-7-1		●	26-3-3	②	●	30-4-1	②
●	20-5-3	②	●	23-7-2	①		26-3-4	①		30-4-2	
●	20-5-4	①					26-4-1		●	30-4-3	①
				25-1-1	①		26-4-2	①		30-5-1	
	22-1-1			25-1-2	①		26-4-3	①	●	30-5-2	①
	22-1-2		●	25-2-1	①		26-5-1		●	30-5-3	①
	22-2-1		●	25-2-2	①		26-5-2			30-5-4	
	22-2-2			25-3-1	①		26-6-1	①		30-6-1	
	22-2-3			25-3-2	①		26-6-2			30-6-2	
	22-2-4			25-3-3			26-6-3			30-6-3	
●	22-3-1	①	●	25-3-4	①		26-6-4			30-6-4	
	22-3-2		●	25-3-5	①	●	26-7-1	①			
	22-3-3			25-3-6			26-7-2			32-1-1	①
●	22-3-4	①		25-3-7			26-7-3			32-2-1	
	22-3-5			25-3-8		●	26-8-1	①		32-2-2	
	22-3-6			25-4-1	①		26-8-2			32-2-3	
	22-3-7		●	25-4-2	②		26-8-3	①		32-3-1	
	22-3-8		●	25-5-1	①		26-8-4			32-3-2	
●	22-3-9	①	●	25-5-2	②		26-8-5			32-3-3	
●	22-3-10	①		25-5-3	①					32-3-4	
	22-3-11		●	25-5-4	②		29-1-1			32-4-1	
				25-5-5		●	29-1-2	①		32-4-2	①
	23-1-1			25-5-6		●	29-1-3	①		32-4-3	①
	23-1-2			25-5-7	①		29-1-4				
●	23-1-3	①	○	25-5-8	①	●	29-1-5	①		34-1-1	①
	23-2-1		○	25-5-9	①	●	29-1-6			34-1-2	①
●	23-2-2	②	○	25-5-10	①		29-2-1			34-1-3	
●	23-3-1	①	○	25-5-11	①		29-2-2			34-1-4	①
●	23-3-2	②	○	25-5-12	①		29-2-3			34-1-5	①
	23-3-3		○	25-5-13	①		29-3-1			34-1-6	①
	23-4-1	①	○	25-5-14	①		29-3-2	①		34-2-1	①
●	23-5-1	①	○	25-5-15	①		29-3-3	①		34-2-2	①
	23-5-2		○	25-5-16	①		29-4-1			34-2-3	①
	23-5-3	①	○	25-5-17	①		29-4-2			34-2-4	

# REVISION HISTORY

# CLARK

Mark	Page	Revision number	Mark	Page	Revision number	Mark	Page	Revision number	Mark	Page	Revision number
	34-3-1			38-1-2	①						
	34-3-2	①		38-2-1							
	34-3-3	①		38-2-2							
	34-3-4	①		38-2-3							
	34-3-5	①		38-3-1							
	34-3-6	①		38-3-2							
	34-3-7	①		38-4-1							
	34-3-8	①		38-4-2							
	34-3-9	①		38-4-3	①						
	34-3-10	①									
	34-4-1	①		40-1-1							
	34-4-2	①		40-1-2	①						
	34-4-3	①		40-1-3							
	34-4-4	①		40-1-4							
	34-4-5	①		40-1-5							
	34-4-6	①		40-1-6							
	34-4-7	①		40-1-7							
	34-4-8			40-2-1							
	34-4-9	①		40-2-2	①						
	34-4-10			40-2-3	①						
	34-5-1	①		40-2-4	①						
	34-5-2	①		40-2-5	①						
	34-5-3	①		40-3-1							
	34-5-4	①									
	34-5-5	①									
	34-5-6	①									
	34-5-7	①									
	34-6-1										
	34-6-2	①									
	34-6-3	①									
	34-6-4	①									
	34-6-5	①									
	34-6-6	①									
	34-6-7	①									
	34-6-8	①									
	34-7-1	①									
	34-7-2	①									
	34-7-3	①									
	34-7-4	①									
	34-8-1										
	34-8-2										
	34-8-3	①									
	34-8-4										
	38-1-1										

## Foreword

This service publication provides information covering normal service, maintenance and repair of the Clark industrial lift trucks noted on the cover. It has been specifically prepared to help owners and service personnel maintain these trucks in efficient and safe operating condition.

This manual is intended for use by persons who are trained and authorized to do lift truck maintenance. It is designed to provide essential information about the correct and safe service maintenance and repair of the truck by trained mechanics or service technicians.

**The Pictorial Contents** lists components or systems by Basic Group Number of Major Parts. Additional content listings are placed at the beginning of each Section in the manual.

**General and detailed service and repair procedures** are outlined (as required) for each component or subsystem. Some procedures include explanations that are common to several components or subsystems. Not every configuration can be pictured. Only "base" module and original designs are shown.

Procedures have been made easier to use by providing specific steps only when necessary and general instructions required to explain the activity, component, assembly, or process being worked on. The technician is expected to include obvious additional steps of standard procedure for removal, disassembly, cleaning, inspection, reassembly, installation, etc., as needed.

To be better prepared to do the necessary service work, take time to completely read the entire procedure, including any special instructions, before starting any work.

**Before beginning to work, the technician is cautioned and expected to:**

- Do all necessary service work.
- Take time to read entire procedures, including any special instructions.
- Contact Clark dealer or, Clark with any questions or procedures not addressed in this manual.

## NOTICE

The descriptions and specifications included in this manual were in effect at the time of printing. Clark reserves the right to discontinue models at any time, or make improvements and changes in specifications or design without notice and without incurring obligation. Specifications, torques, pressures, measurements, adjustments, illustrations and other items may change at any time. Contact your authorized CLARK dealer for information on possible updates or revisions.

---

**NOTE :**



**CONTENTS**

- Group SA - Safe Maintenance**
- Group PS - Periodic Service**
- Group 12 - Battery**
- Group 13 - Electrical Switches**
- Group 16 - Electrical Motors**
- Group 17 - Electrical Schematics**
- Group 19 - Electrical Controls**
- Group 20 - Drive Axle**
- Group 22 - Wheels and Tires**
- Group 23 - Brake System**
- Group 25 - Steering Gear**
- Group 26 - Steering Axle**
- Group 29 - Hydraulic Pump, Sump and Filters**
- Group 30 - Hydraulic Control Valves**
- Group 31- Hydraulic Supply System**
- Group 32 - Cylinders**
- Group 33 - Selector Solenoid Valve**
- Group 34 - Upright**
- Group 40 - Specifications**

---

**NOTE :**

**GROUP SA****SAFE MAINTENANCE**

<b>Safety .....</b>	<b>Section 1</b>
<b>Lifting, Jacking, and Blocking .....</b>	<b>Section 2</b>
<b>Towing .....</b>	<b>Section 3</b>

NOTE :

**Section 1****Safety**

<b>Safety Signs and Messages .....</b>	<b>2</b>
<b>Safe Maintenance Practices .....</b>	<b>2</b>
General Shop Precautions .....	4

## Safety Signs and Messages

Safety signs and messages in this manual and on the lift truck provide instructions and identify specific areas where potential hazards exist and special precautions should be taken. Be sure you know and understand the meaning of these instructions, signs, and messages. Damage to the truck, death, or serious injury to you or other persons may result if these messages are not followed.

### NOTE

This message is used when special information is required relating to procedures, equipment, tools, pressures, capacities, and other special data.

### IMPORTANT

This message is used when special precautions should be taken to ensure a correct action or to avoid damage to, or malfunction of, the truck or a component.



### CAUTION

This message is used as a reminder of safety hazards that can result in personal injury if proper precautions are not taken.



### WARNING

This message is used when a hazard exists that can result in injury or death if proper precautions are not taken.



### DANGER

This message is used when an extreme hazard exists that can result in injury or death or serious injury if proper precautions are not taken.

The above terms have been adopted by Clark Material Handling Company. The same terms may be used in different context in service literature supplied directly or indirectly by vendors or truck components.

## Safe Maintenance Practices

The following instructions have been prepared from current industry and government safety standards applicable to industry truck operation and maintenance. These recommended procedures specify conditions, methods, and accepted practices that aid in the safe maintenance of industrial trucks. They are listed here for the reference and safety of all workers during maintenance operations. **Carefully read and understand these instructions and the specific maintenance procedures before attempting to do any repair work.**

When in doubt of any maintenance procedure, please contact your local Clark dealer.

1. Powered industrial trucks can become hazardous if maintenance is neglected. Therefore, suitable maintenance facilities, trained personnel, and procedures must be provided.
2. Maintenance and inspection of all powered industrial trucks shall be done in conformance with the manufacturer's recommendations.
3. A scheduled planned maintenance, lubrication, and inspection program shall be followed.
4. Only trained and authorized personnel shall be permitted to maintain, repair, adjust, and inspect industrial trucks. Work should be performed in accordance with the manufacturer's specifications.
5. Properly ventilate work area, vent exhaust fumes, and keep shop clean and floor dry.
6. Avoid fire hazards and have fire protection equipment present in the work area. Do not use an open flame to check for level or leakage of fuel, electrolyte, or coolant. Do not use open pans of fuel or flammable cleaning fluids for cleaning parts.
7. Before starting work on truck:
  - a. Wear eye protection and remove all jewelry.
  - b. Raise drive wheels off of floor or disconnect power source. Use blocks or other positive truck positioning devices
  - c. Disconnect battery before working on the electrical system.
8. Before working on engine fuel system of gasoline or diesel-powered trucks, be sure the fuel shut-off valve is closed.
9. Operation of the truck to check performance must be conducted in an authorized, safe, clear area.

10. Before starting to drive truck:
  - a. Be in operating position.
  - b. Be sure parking brake is engaged.
  - c. Put direction control in neutral.
  - d. Start engine.
  - e. Check functioning of direction and speed controls, steering, brakes, warning devices, and any load handling attachments.
11. Before leaving truck
  - a. Stop truck.
  - b. Put directional control in neutral.
  - c. Apply the parking brake.
  - d. Turn key switch OFF.
  - e. Put blocks at the wheels if truck is on an incline.
12. Brakes, steering mechanisms, control mechanisms, warning devices, lights, governors, guards, safety devices, and frame members must be carefully and regularly inspected and maintained in a safe operating condition.
13. Special trucks or devices designed and approved for hazardous area operation must receive special attention to ensure that maintenance preserves the original, approved, safe-operating features.
14. Fuel systems must be checked for leaks and condition of parts. Extra special consideration must be given in the case of a leak in the fuel system. Action must be taken to prevent the use of the truck until the leak has been corrected.
15. The truck manufacturer's capacity, operation, and maintenance instruction plates, tags, or decals must be maintained in legible condition.
16. Batteries, motors, controllers, limit switches, protective devices, electrical conductors, and connections must be inspected and maintained in conformance with good practices. Special attention must be paid to the condition of electrical insulation.
17. To avoid injury to personnel or damage to the equipment, consult the manufacturer's procedures in replacing contacts on any battery connection.
18. Industrial trucks must be kept in a clean condition to minimize fire hazards and help in the detection of loose or defective parts.
19. Modifications and additions that affect capacity and safe truck operation must not be done without the manufacturer's prior written approval. Capacity, operation and maintenance instruction plates, tags, or decals must be changed accordingly. This is an OSHA requirement.
20. Care must be taken to assure that all replacement parts, including tires, are interchangeable with the original parts and of a quality at least equal to that provided in the original equipment. Parts, including tires, are to be installed per the manufacturer's procedures. Always use genuine CLARK or CLARK approved parts.
21. Use special care when removing heavy components from the truck, such as counterweight, seat deck, upright, etc. Be sure that lifting and handling equipment is of the correct capacity and in good condition. Also, this removal may upset stability of the truck. The frame must always be safely blocked for major component removal.

**NOTE**

**Become familiar with additional operating and maintenance safety instructions contained in the following publications:**

ASME B56.1 - Safety Standard for Low Life and High Lift Trucks. Published by: American Society of Mechanical Engineers, Three Park Avenue, New York, NY 10016.

NFPA 505 - Powered Industrial Trucks. Including Type, Areas of Use, Maintenance and Operation. Available from: National Fire Protection Assoc., Inc., Batterymarch Park, Quincy, MA 02269.

General Industrial Standards, OSHA 2206: OSHA Safety and Health Standards (29 CFR 1910), Subpart N-Materials Handling and Storage, Section 1910.178 Powered Industrial Trucks. For sale by: Superintendent of Documents, U.S. Government Printing Office, Washington, DC 20402.

**General Shop Precautions**

The following list contains general precautions that should be followed when working on a lift truck.

- Always wear safety glasses for eye protection.
- Remove rings, watches, loose jewelry and open clothing before working on a vehicle to avoid serious injury.
- Do not smoke while working on a vehicle.
- Put power key switch in the OFF position, unless otherwise required by the procedure.
- Set the parking brake. Place chocks to the front and rear surfaces of the tires to provide further restraint from inadvertent vehicle movement.
- Use safety stands or blocks whenever a procedure requires you to be under the vehicle.
- Service electric truck batteries in a well-ventilated area to avoid the danger of lighting explosive gases.
- Follow the Safety Instructions outlined in Group 12, Battery Handling.
- Always discharge the capacitors prior to working on or around electrical components.
- Avoid contact with battery acid. The battery contains corrosive acid which can cause injury. Follow the instructions outlined in Group 12 and those instructions received with your battery and charger.

**Cautions**

The following is a list of “CAUTIONS” connected with the operation and maintenance of trucks equipped with solid state control panels.



**CAUTION**

**WELDING ON TRUCKS**

1. **Make sure the truck has no grounds.**
2. **Disconnect truck battery.**
3. **Protect electrical wiring and components from weld spatter with a shield.**
4. **Ventilate battery or remove battery from truck.**  
**If the above is not followed, damage can result to wiring and electrical components on a solid state control truck.**



**CAUTION**

**DO NOT STEAM-CLEAN**

**Do not steam-clean a solid state controlled truck. Excessive moisture will interfere with proper operation of the solid state components.**

Solid state controls should be cleaned at regular intervals. Blowing dirt off with an air (207 kPa [30 psi] max.) hose periodically will, for the most part, eliminate any serious cleaning problems. For a more thorough cleaning, water may be hosed over the control. A mild detergent may be applied, such as that used for washing dishes. The detergent should be rinsed off, and the controls must be thoroughly air-dried before putting truck into service.

Periodic cleaning should preclude the need for using a degreaser. However, if a degreaser is used, we recommend Clark #1801146 Degreaser, or the equivalent to MS-180 Freon TF Degreaser and Cleaner. Only approved solvents should be used to clean solid state control components.



**CAUTION**

**CHECK POLARITY**

**Battery polarity must be correct or the truck will not operate.**



**CAUTION**

**USE TRUCK BATTERY ONLY**

**Do not use a motor generator unit such as “ready power” or a battery charger to move and/or check this truck as serious damage may occur.**

**IMPORTANT**

**SAFETY NOTICE**

**Read and understand all Safety Precautions and Warnings before performing repairs on lift trucks.**

Appropriate service methods and proper repair procedures are essential to the safe, reliable operation of industrial trucks, as well as the personal safety of the individual doing the work. This Service Manual provides general directions for accomplishing service and repair work with tested, effective techniques. Following them will help assure successful repair and reliable truck operation.



There are numerous variations in procedures, techniques, tools and parts used for servicing industrial trucks, as well as in the skill of the person doing the work.

This manual cannot possibly anticipate all such variations and provide advice or precautions as to each. Accordingly, anyone departing from the instructions provided in this manual, through procedures used or choice of tools, materials, and parts may jeopardize his or her personal safety and the safety of the vehicle user.

Improper or careless techniques cause accidents. Don't take chances with incorrect or damaged equipment. Read and understand the procedures for safe operation and maintenance outlined in this manual.

**Drive and work safely. Follow the safety signs and their messages displayed in the work area, on the truck, and in this manual.**

## Section 2

### Lifting, Jacking, and Blocking

Raising Drive Wheels .....	2
Changing the Upright in Raised Position .....	3
Raised Rear of Truck .....	3
Raised Entire Truck .....	4
Shipping Tie-Down Instructions .....	5

**WARNING**

Lifting or jacking any large piece of equipment such as a fork truck presents obvious hazards. It must be done with great care and forethought. Consult the truck weight information in Group 40, Specifications, to ensure that your lifting equipment is of adequate capacity.



### CAUTION

To perform these service procedures, first:

- Park truck on a level surface.
- Put the upright in a vertical position and lower the carriage fully down.
- Return control handle to neutral and turn key switch OFF.



### WARNING

Defective equipment can cause accidents:

All tools and lifting equipment must be in good condition, meet the load capacity requirements and have OSHA labels when required. Tools with defects can fail, causing severe injury or death.

5. Block the truck under the frame behind the drive wheels with solid blocking.
6. Turn key switch OFF.
7. Check for safe clearance between drive wheels, block and floor.
8. Check the stability of the truck. Be sure that the blocks are located securely under the frame before operating the drive motor or working on truck.
9. Lower the drive wheels to the floor by reversing this procedure.
  - Turn key switch ON.
  - Tilt upright fully back.
  - Turn key switch OFF.
10. Remove the blocks from under the frame and upright rails.

## Raising Drive Wheels

This procedure uses the upright as a lever to lift the drive wheels off the floor and prevent accidents due to inadvertent powering of the drive wheels.

1. Park the truck safely.
2. Turn key switch ON. **Tilt the upright fully back.**
3. Put a solid 100 x 100 mm (4 x 4 inch) hardwood block under the front section of each upright rail. Put a 3-6 mm (0.125-0.250 inch) steel plate on top of each block.
4. **Tilt the upright fully forward.** This will raise the drive wheels off the floor.

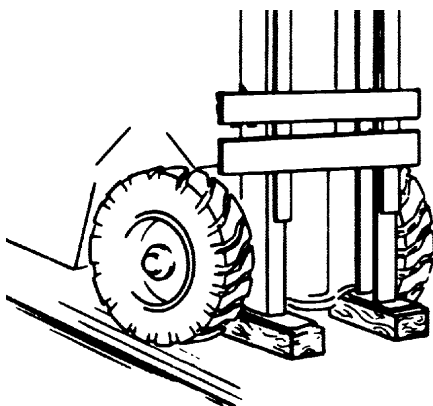

GENERIC ILLUSTRATION

## Chaning the Upright in Raised Position

This procedure is used to safely provide clearance for access from the front of truck to components on or near the drive axle.

1. Park truck safely.
2. Put blocks at front of and rear of drive wheels.
3. Raise upright carriage.
4. Chain the center inner rail tie bar to the top outer rail tie bar as shown.

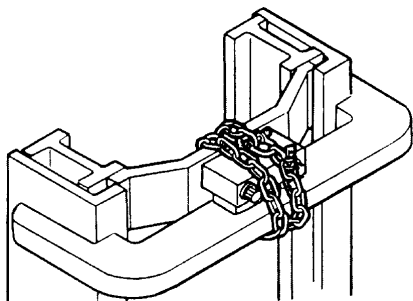

Triple Stage Uprights: Chain the center intermediate rail tie bar and the lower inner rail tie bar to the top outer rail tie bar.

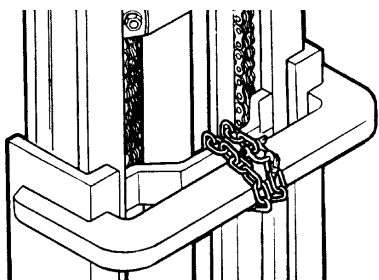

5. Reverse the procedure to remove the chains.

**WARNING**

Keep hands, tools, etc. out of upright.

## Raising Rear of Truck

The truck may be raised at the rear by jacking and blocking under the center of the frame member at either the front or rear steer axle mounting, or under the center section of the steer axle.

Refer to truck data plate for truck weights.

**WARNING**

**An incorrectly installed counterweight can move or fall unexpectedly. NEVER LIFT OR BLOCK A TRUCK USING THE COUNTERWEIGHT. Failure to follow procedures outlined in this manual can result in injury or death.**

1. Park truck safely.
2. Put blocks at front and rear of drive wheels.

**CAUTION**

**If possible, remove the battery from truck to reduce weight for added safety and ease of jacking.**

3. Put a floor jack under the steer axle mounting frame member, centered between the two wheels.

**WARNING**

**Never lift the truck by the counterweight.**

**NOTE**

**If there is insufficient clearance under frame for your jack, the truck may first be driven onto shims, such as 25x150x300 mm(1 x 6 x 12 in.) pieces of board, to increase the truck frame underclearance.**